

LEGEND

- ① EX PCC BASE COURSE 9"
- ② EX SUB-BASE GRANULAR MATERIAL 4"
- ③ EX HOT-MIX ASPHALT SURFACE (VAR. 3"-6 1/2")
- ④ EX HOT-MIX ASPHALT SURFACE COURSE, MIX "C", N50 (1 1/2")
- ⑤ EX AGG. SHOULDER, TYPE B
- ⑥ PR HOT-MIX ASPHALT SHOULDERS 8"
- ⑦ PR PAVEMENT MARKING LINE 5"
- ⑧ PR GRADING AND SHAPING FORESLOPES

STA 575+46.50 to STA. 643+18.70  
 STATION EQN. STA. 643+18.70(BK) = STA. 645+11.04(AH)  
 STA. 645+11.04 TO STA.737+68.43  
 STATION EQN. STA. 737+68.43(BK) = STA. 8+35.81(AH)  
 STA. 8+35.81 TO STA. 13+50.00  
 BRIDGE OMISSION STA. 13+50.00 TO STA. 22+50.00  
 STA. 22+50.00 TO STA. 24+06.86  
 STATION EQN. STA. 24+06.86(BK) = STA. 753+39.94(AH)  
 STA. 753+39.94 TO STA. 764+90.6

\* When the superelevation rate exceeds 4.0%, the shoulder shall be sloped so that the algebraic difference between pavement and shoulder will not be greater than 8%.

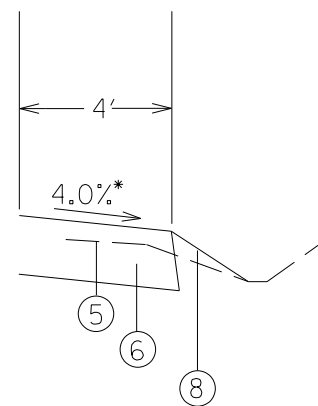

At locations as designated by Engineer

FILE NAME = c:\pwork\pwork\sparksgw\10249905\0672E18-sht-typical.dgn	USER NAME = sparksgw	DESIGNED -	REVISED -	<b>STATE OF ILLINOIS DEPARTMENT OF TRANSPORTATION</b>	<b>TYPICAL SECTION</b>			F.A.P. RTE.	SECTION	COUNTY	TOTAL SHEETS	SHEET NO.
	PLOT SCALE = 5.0000' / in.	CHECKED -	REVISED -					614	147RS-7, 148RS-4	MORGAN	14	5
PLOT DATE = Aug-19-2011 01:53:12PM	DATE -	REVISED -	SCALE:		SHEET NO.	OF SHEETS	STA.	TO STA.	ILLINOIS FED. AID PROJECT			
								CONTRACT NO. 72E18				