

**FIELD SPLICE 11 DETAIL**  
(6 Required)

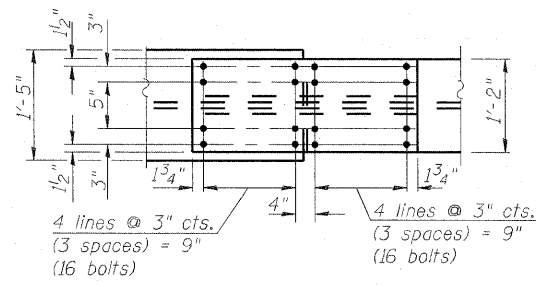

**FIELD SPLICE 12A DETAIL**  
(6 Required)

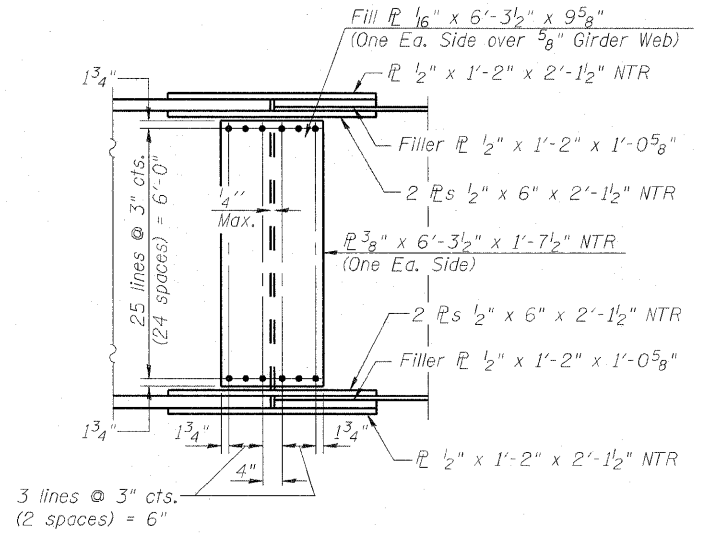
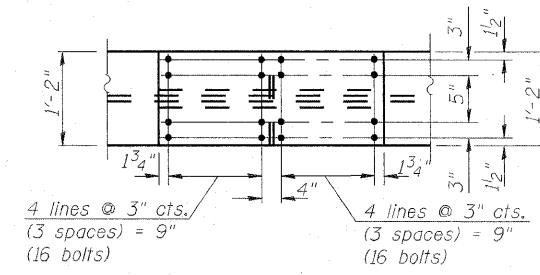
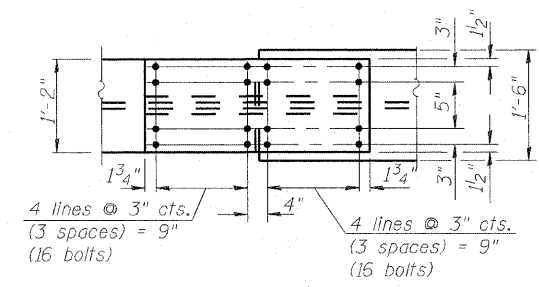
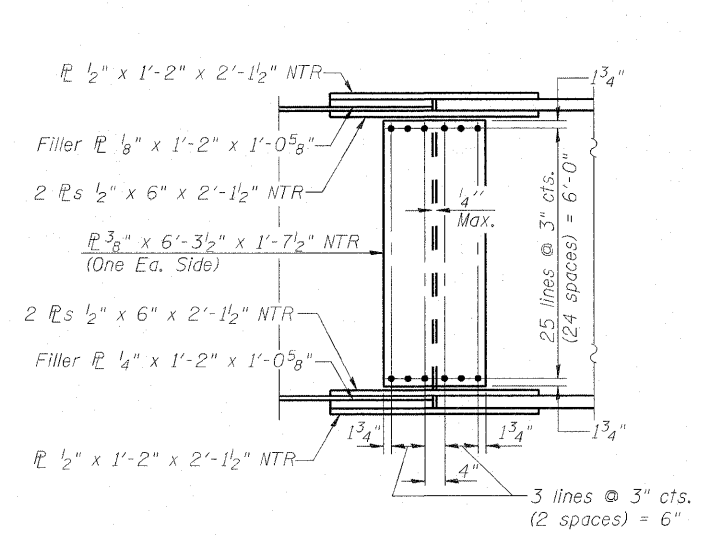
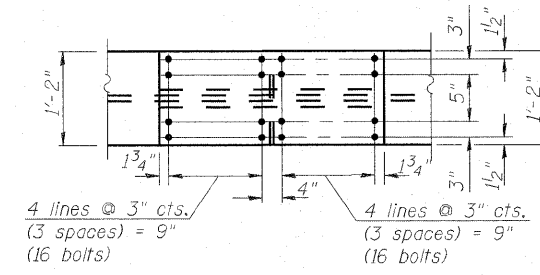

**FIELD SPLICE 12B DETAIL**  
(6 Required)

- Notes:
1. AASHTO M270 Grade 50 steel shall be used for all splice plates, except fill plates which may be AASHTO M270 Grade 36 or 50.
  2. Load carrying components designated "NTR" shall conform to the Supplemental Requirements for Notch Toughness (Zone 2), including all flange and web splice plates (except fill plates).
  3. Fasteners shall be AASHTO M164 Type 1, mechanically galvanized bolts. Bolts  $\frac{7}{8}$  in.  $\phi$ , holes  $\frac{15}{16}$  in.  $\phi$ , unless otherwise noted. Design assumes threads in shear plane and Class A slip surface.
  4. The Contractor is alerted that differences in web thickness across the splice create a slight misalignment of the webs that may need to be accounted for when detailing cross frames in shop drawings in order to properly control geometry and avoid any fit-up issues. The web fill plates are shown with one each side of web; alternatively, they may be detailed and installed on the same side of the web at rows of adjacent splices in order to minimize girder spacing differences at these locations.

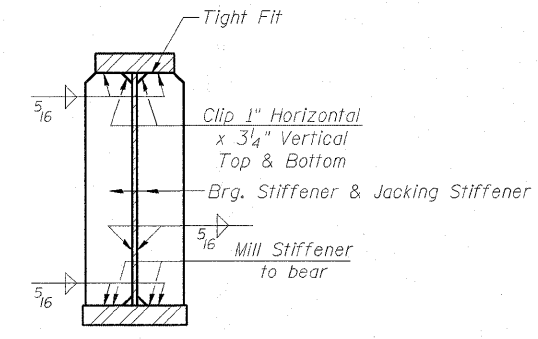

**SECTION AT PIERS & ABUTMENT**



USER NAME =	DESIGNED - P.J.L.	REVISED -
PLOT SCALE = 8x2 1/4" / IN.	DRAWN - BRD	REVISED -
PLOT DATE = 6/30/2011	CHECKED - CHY	REVISED -
	DATE - 07-01-11	REVISED -

STATE OF ILLINOIS  
DEPARTMENT OF TRANSPORTATION

STRUCTURAL STEEL DETAILS - UNIT 4 - II  
I-70E OVER I-55, CSX & KCS RAILROADS

SCALE: SHEET S-115 OF S-234 SHEETS STA. TO STA.

F.A.I. RTE. 70	SECTION 82-1-B-2	COUNTY ST. CLAIR	TOTAL SHEETS 399	SHEET NO. 242
S.N. 082-0322 & S.N. 082-0324		CONTRACT NO. 76C76		
FED. ROAD DIST. NO. ILLINOIS FED. AID PROJECT				