

When "A" is 3'-6" or less, the temporary concrete barrier shall be anchored to the new slab according to Detail I or Detail II. No anchorage is required when "A" is greater than 3'-6".

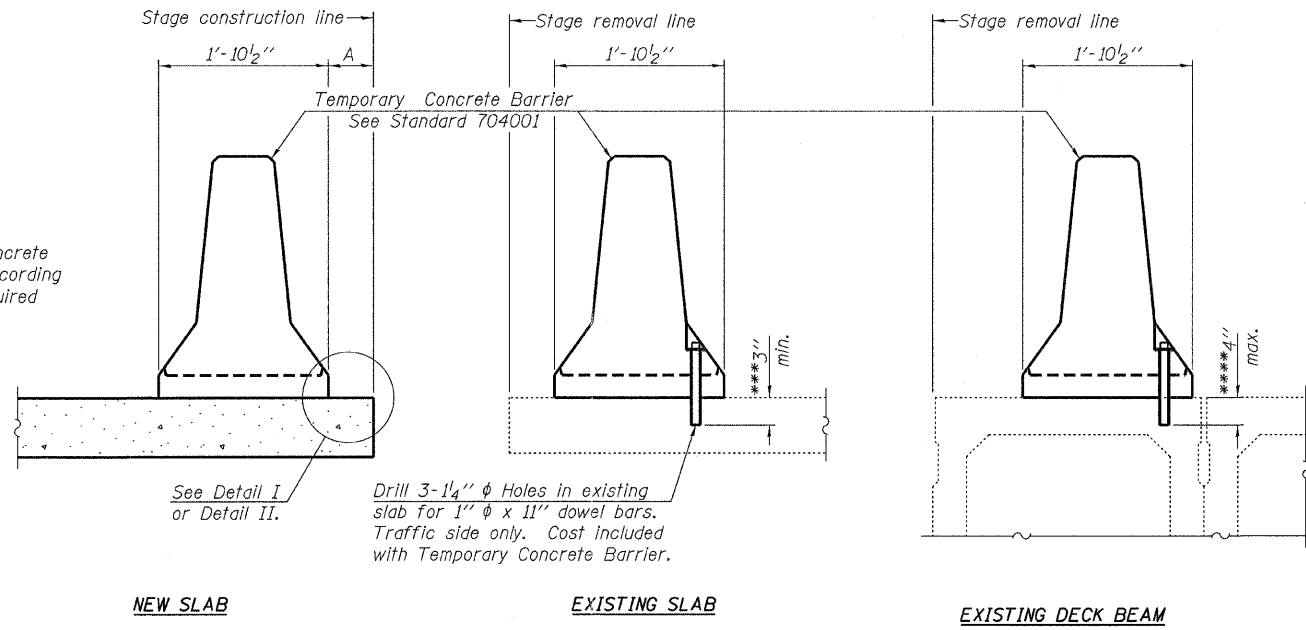

SECTIONS THRU SLAB OR DECK BEAM

NOTES

Detail I - With Bar Splicer or Couplers:
Connect one (1) 1" x 7" x "W" steel \bar{L} to the top layer of couplers with 2-5/8" ϕ bolts screwed to coupler at approximate \bar{C} of each barrier panel.

Detail II - With Extended Reinforcement Bars:
Connect one (1) 1" x 7" x "W" steel \bar{L} to the concrete slab or concrete wearing surface with 2-5/8" ϕ Expansion Anchors or cast in place inserts spaced between the top layer of reinforcement at approximate \bar{C} of each barrier panel.

Cost of anchorage is included with Temporary Concrete Barrier. The 1" x 7" x "W" plate shall not be removed until stage II construction forms and all reinforcement bars are in place and the concrete is ready to be placed.

*** Dimension shown is minimum required embedment into concrete. If hot-mix asphalt wearing surface is present, minimum embedment shall be in addition to wearing surface depth.

**** If existing deck beam is to remain in place after stage construction, embedment shall only be into wearing surface and not into existing deck beam concrete.

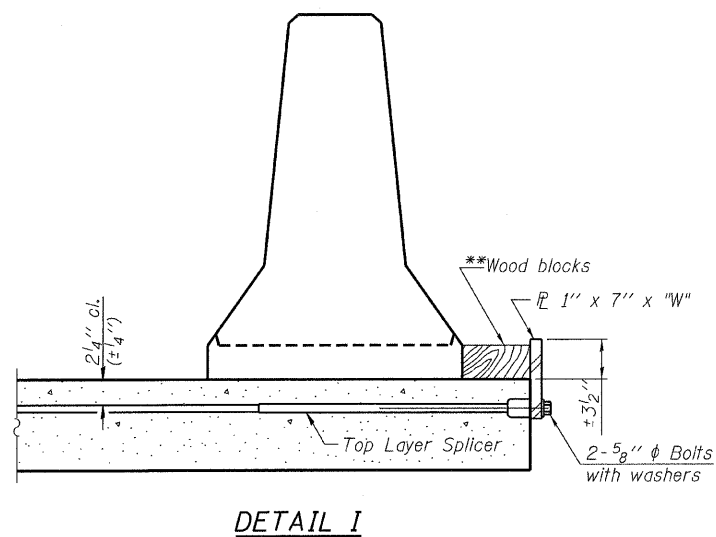

DETAIL I

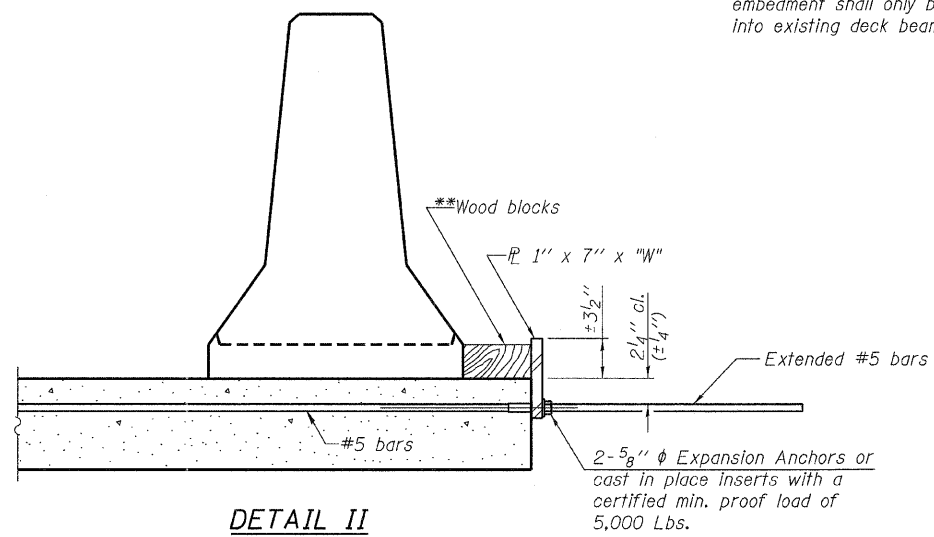

DETAIL II

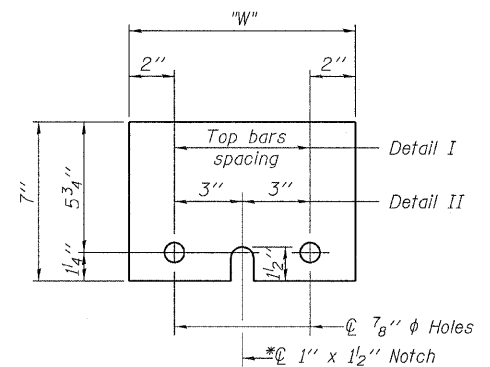

STEEL RETAINER \bar{L} 1" x 7" x "W"

* Required only with Detail II

** Wood blocks may be omitted when required to provide minimum stage traffic lane width. When the wood blocks are omitted, the concrete barrier shall be in direct contact with the steel retainer plate.

"W" = Top bars spacing + 4"

R-27

7-1-10

FILE NAME = 090148-shr-bridge.dgn	USER NAME =	DESIGNED - A.S.L.	REVISED -	STATE OF ILLINOIS DEPARTMENT OF TRANSPORTATION	TEMPORARY CONCRETE BARRIER FOR STAGE CONSTRUCTION STRUCTURE NO. 097-0076	F.A.P.	SECTION	COUNTY	TOTAL SHEETS	SHEET NO.	
HAMPTON, LENZINI AND RENWICK, INC. 3188 STEVENSON DRIVE, SUITE 201 SPRINGFIELD, ILLINOIS 62702	PLOT SCALE =	CHECKED - C.C.S.	REVISED -			328	105B-1	WHITE	54	25	
HLR ILLINOIS PROFESSIONAL DESIGN FIRM L5 / P.E. / S.E. CORP. 184.000889	PLOT DATE = 7/13/2011	DRAWN - D.A.B.	REVISED -			CONTRACT NO. 78161					
		CHECKED - M.D.C.	REVISED -			SHEET NO. 4 OF 26 SHEETS					
						ILLINOIS FED. AID PROJECT					