

When cantilever forming brackets are used, the work shall be done according to Article 503.06(b) of the Standard Specifications, except as modified below and in the details shown on this sheet.  
 The finishing machine rails shall be placed on the top flange of the exterior beams.  
 The beams or girders, supporting cantilever forming brackets, shall be tied together at 4 foot intervals.  
 For Standard construction, or Stage Construction the Hardwood bracing materials shall be placed as shown between webs of beams in each bay.

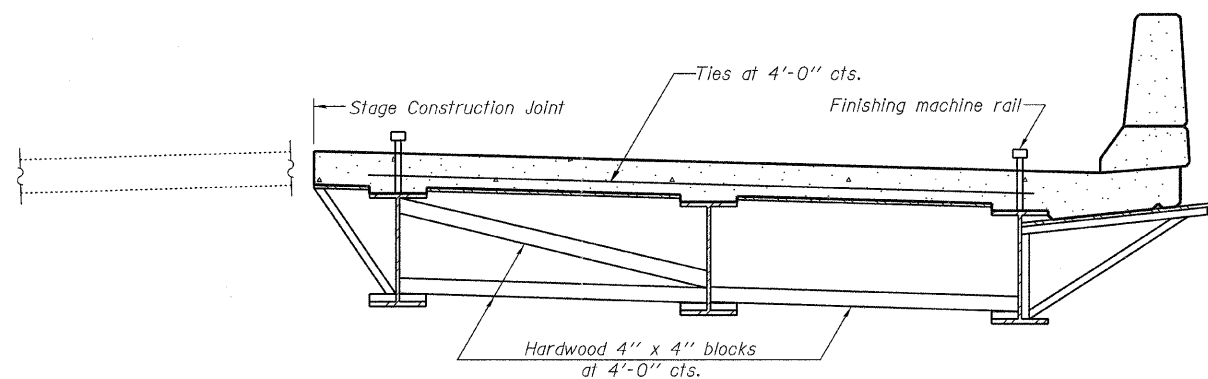

**FORM BRACES FOR  
STAGE CONSTRUCTION**

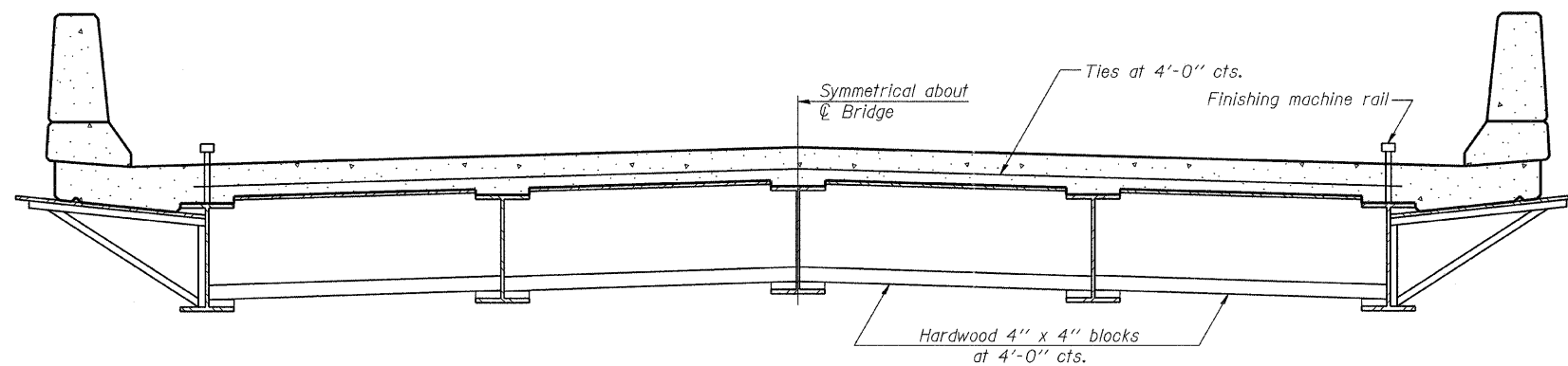

**FORM BRACES FOR  
STANDARD CONSTRUCTION**

SB-1

7-1-10

FILE NAME = 090140-shr-bridge.dgn	USER NAME =	DESIGNED - A.S.L.	REVISED -	<b>STATE OF ILLINOIS DEPARTMENT OF TRANSPORTATION</b>	<b>CANTILEVER FORMING BRACKETS FOR SUPERSTRUCTURES WITH W27 BEAMS AND SMALLER STRUCTURE NO. 097-0076</b>	F.A.P.	SECTION	COUNTY	TOTAL SHEETS	SHEET NO.
HAMPTON, LENZINI AND RENWICK, INC. 3636 STEVENSON DRIVE, SUITE 201 SPRINGFIELD, ILLINOIS 62703		CHECKED - C.C.S.	REVISED -			328	105B-1	WHITE	54	44
PLLOT SCALE =		DRAWN - D.A.B.	REVISED -			CONTRACT NO. 78161				
PLLOT DATE = 7/13/2011		CHECKED - M.D.C.	REVISED -			SHEET NO. 23 OF 26 SHEETS				
				ILLINOIS FED. AID PROJECT						