

ROUTE NO.	SECTION	COUNTY	TOTAL SHEETS	SHEET NO.
T.R. 297	07-0617-00-BR	MARION	12	9
FEDERAL AID PROJECT		ILLINOIS	PROJECT	

CONTRACT NO.

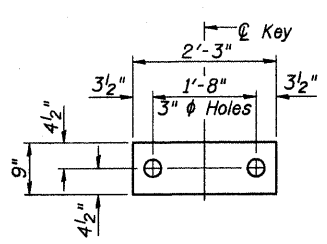

**FABRIC BEARING PAD**  
(Interior)

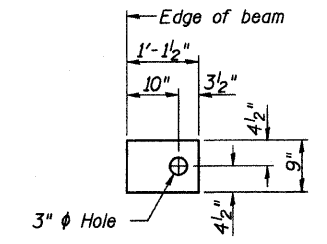

**FABRIC BEARING PAD**  
(Exterior)

**FIXED**

Notes:  
All bearing pads shall be 1" thick.  
Omit holes when using expansion bearings.  
Expansion bearing pad shall be bonded to the substructure.

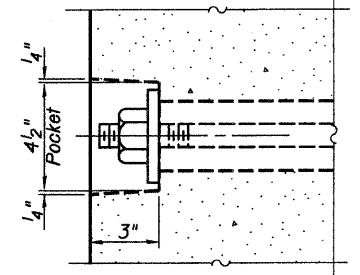

**SECTION A-A**

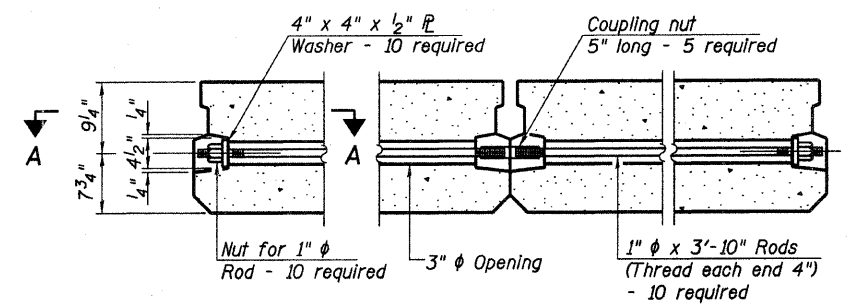

**TYPICAL TRANSVERSE TIE ASSEMBLY**  
(Quantities for one span)

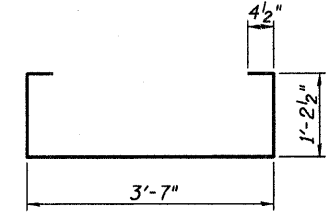

**BAR S(E)**

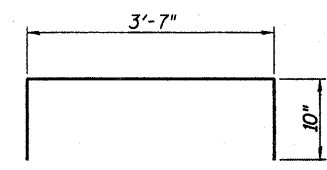

**BAR S1(E)**

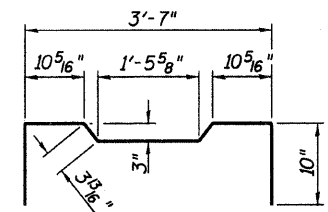

**BAR U(E)**

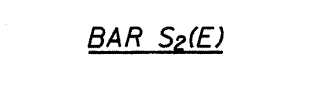

**BAR S2(E)**

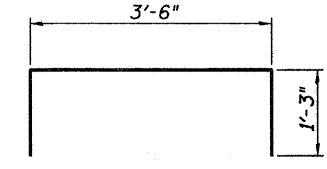

**BAR U1(E)**

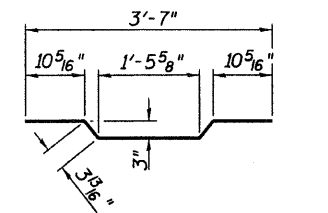

**BAR A1(E)**

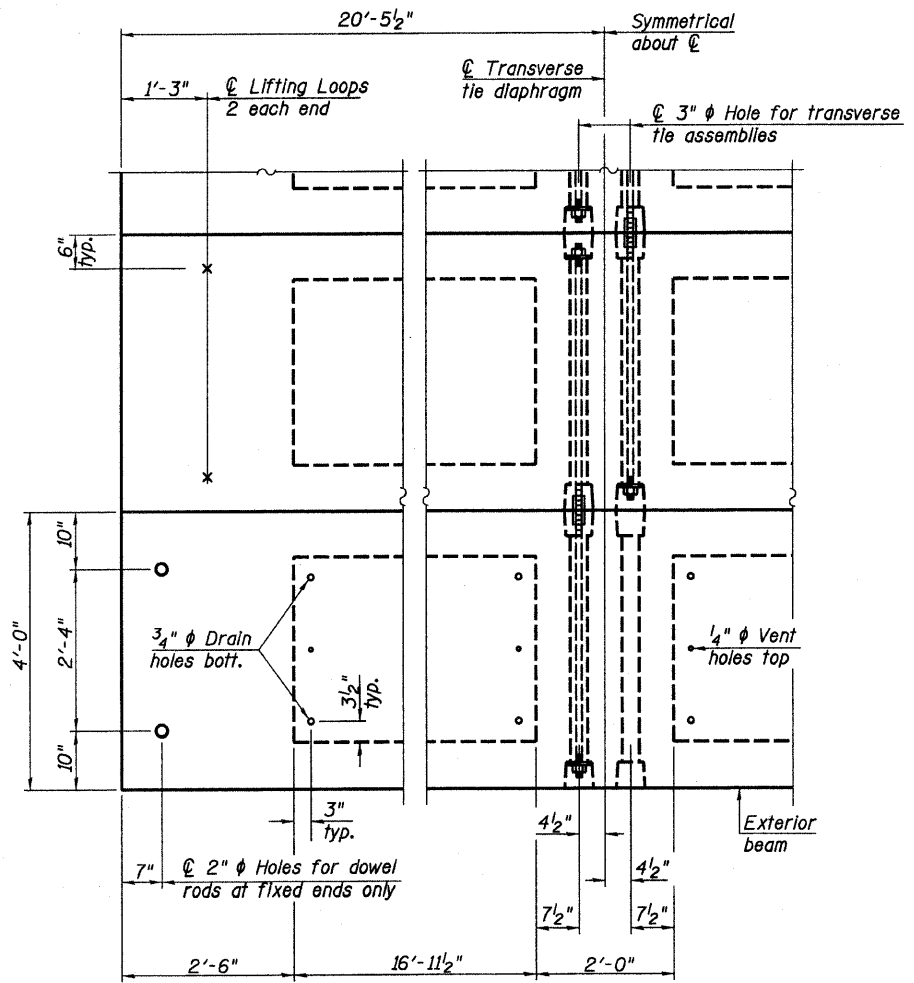

**PLAN VIEW**

Note: Connect beams in pairs with the transverse tie configuration shown.

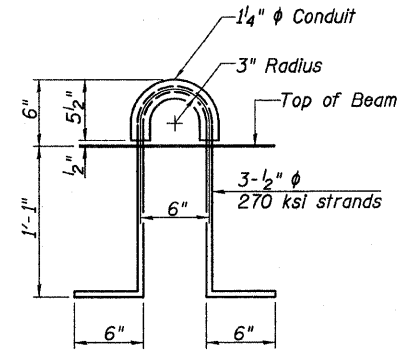

**LIFTING LOOP DETAIL**

**NOTES**

Prestressing steel shall be uncoated high strength, low relaxation 7-wire strand, Grade 270. The nominal diameter shall be 1/2" and the nominal cross-sectional area shall be 0.153 sq. in.  
The 1" diameter rods in the transverse tie assembly shall be tightened to a snug fit and the threads set. Pockets on exterior faces of bridge shall be filled with grout after transverse tie assembly is in place.  
Reinforcement bars shall conform to ASTM A 706, Grade 60. (See Supplemental Specifications).  
A minimum 2 1/2" diameter lifting pin shall be used to engage the lifting loops during handling.  
Two 1/8" fabric adjusting shims of the dimensions of the exterior bearing pad shall be provided for each bearing pad location.  
Corrosion Inhibitor, per Article 1020.05(b)(12) and 1021.06 of the Standard Specifications, shall be used in the concrete for precast prestressed concrete deck beams.  
Compressive strength of prestressed concrete, f'c, shall be 6000 psi.  
Compressive strength of prestressed concrete at release, f'ci, shall be 5000 psi.  
Rail post anchor devices shall be cast into outside beam as elsewhere specified.  
Keyway surfaces shall be cleaned to remove form oil or other bond breaking material prior to shipment of the beams. Cleaning shall be done by sandblasting the keyway areas between the top of the beam and the bottom edge of the key.

**DESIGN STRESSES**

f's = 270,000 p.s.i. (1/2" diameter Strand)  
f'sl = 201,960 p.s.i. (1/2" diameter Strand)  
Ft = 30,900 lbs per strand  
fy = 60,000 p.s.i. Reinf. bars  
f'ci = 5,000 p.s.i.

Note: See sheet 4 of 12 for Bill of Material.

**RHUTASEL and ASSOCIATES, INC.**  
CONSULTING ENGINEERS & LAND SURVEYORS  
CENTRALIA, ILLINOIS      FREEBURG, ILLINOIS

PREPARED FOR  
**AECOM**  
200705482

Date: 08/15/2011  
Design: WDL  
Drawn: JSD  
Job No.: 51010

**P.P.C. DECK BEAM  
DETAILS AND NOTES**  
  
24' ROADWAY  
17" x 48" BEAMS  
0° SKEW