

DETAIL A

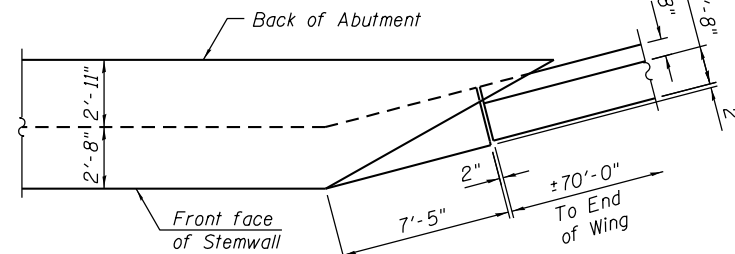

DETAIL B

CORNER DETAILS

Note:
Existing reinforcement shall be cleaned and incorporated into the new construction. Cost included with Concrete Removal.
On all sections, horizontal dimensions at right angles.

*****Align Bar Splicer parallel to approach slab reinforcement.

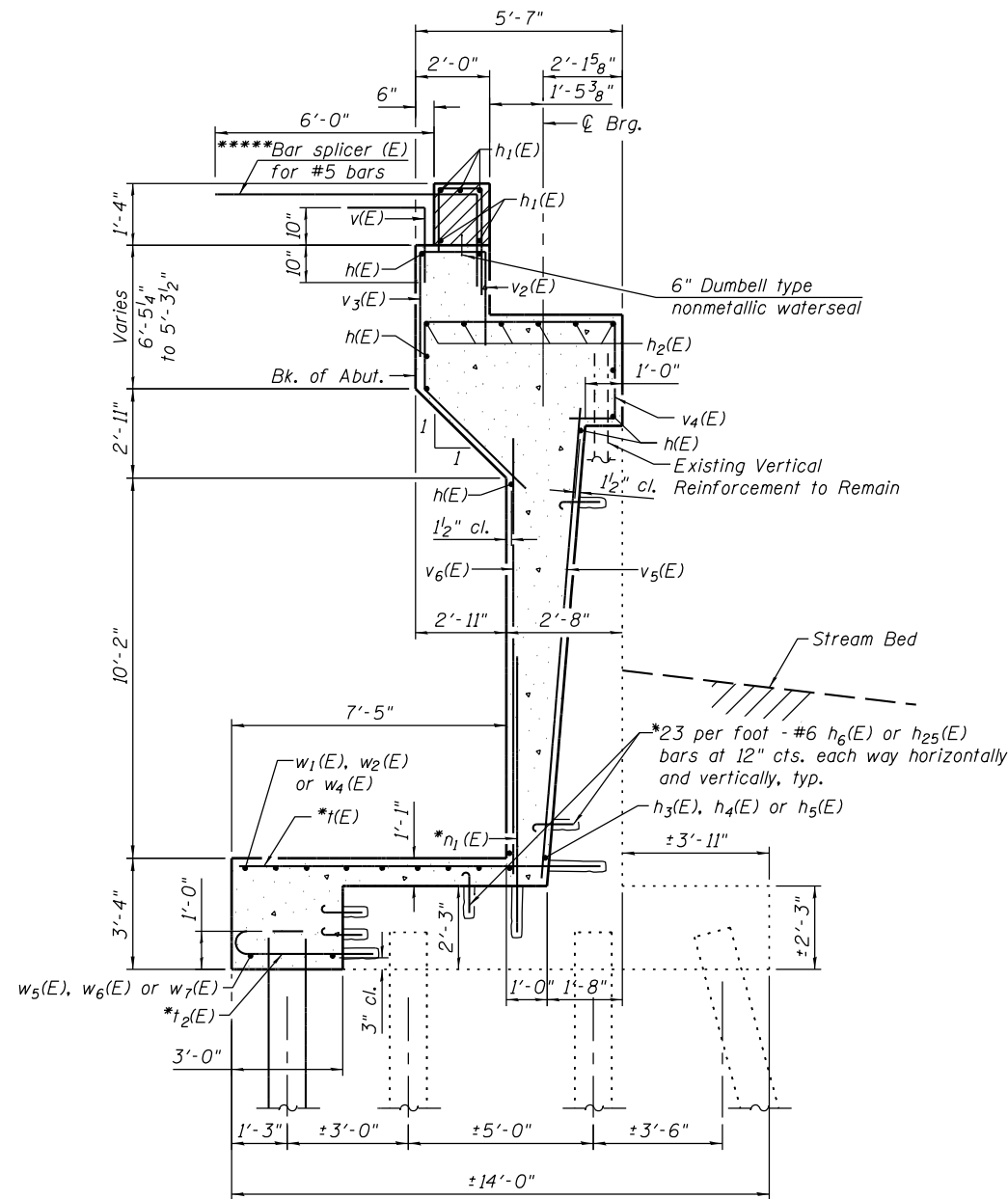

SECTION A-A

* Epoxy grout $h_6(E)$, $h_{25}(E)$, $t(E)$, $t_1(E)$, $t_2(E)$ and $n_1(E)$ bars in drilled holes of the depth specified by the manufacturer to achieve full tension capacity and according to Article 584 of the Standard Specifications. Bar lengths shown are based on 9 inch min. drilled holes. Actual bar lengths are required to be adjusted by the contractor before ordering of material.

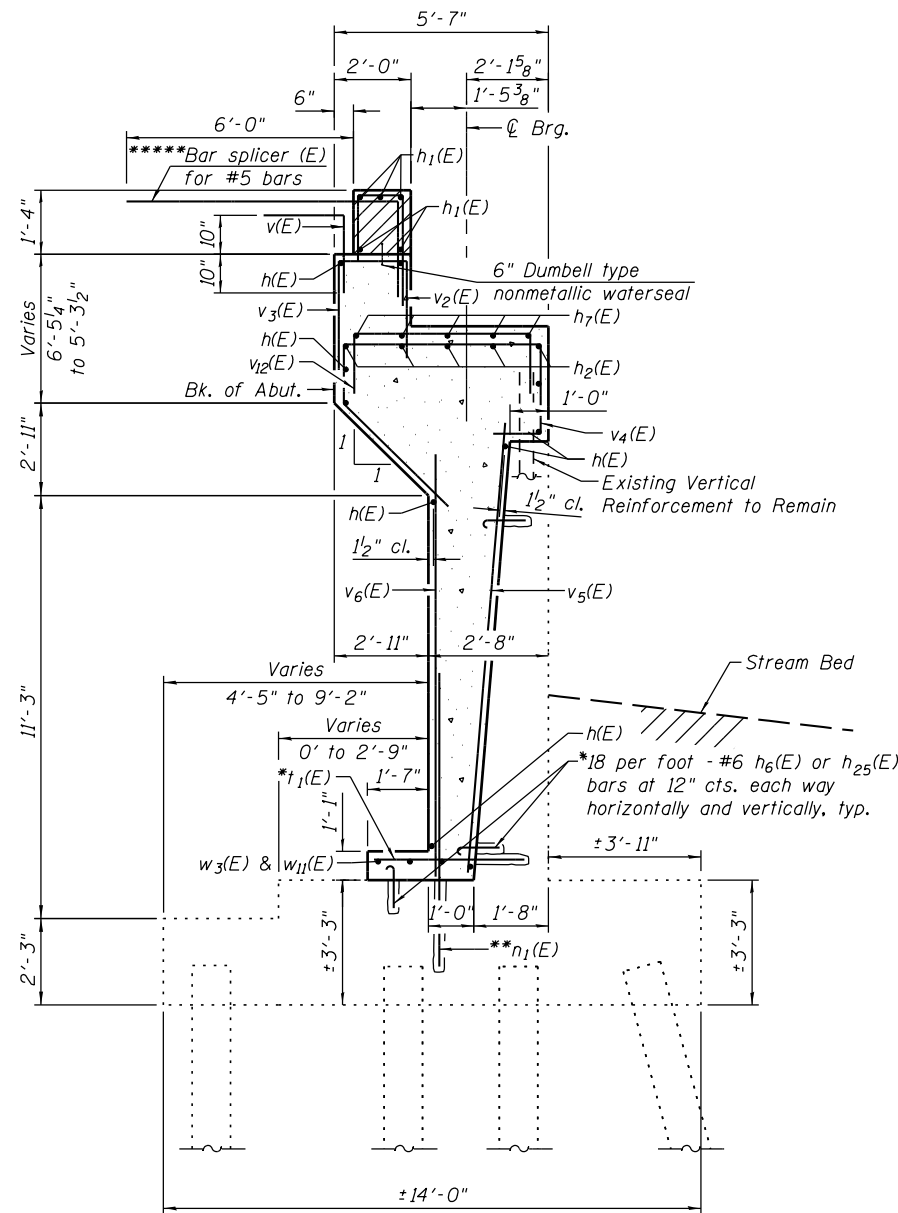

SECTION B-B

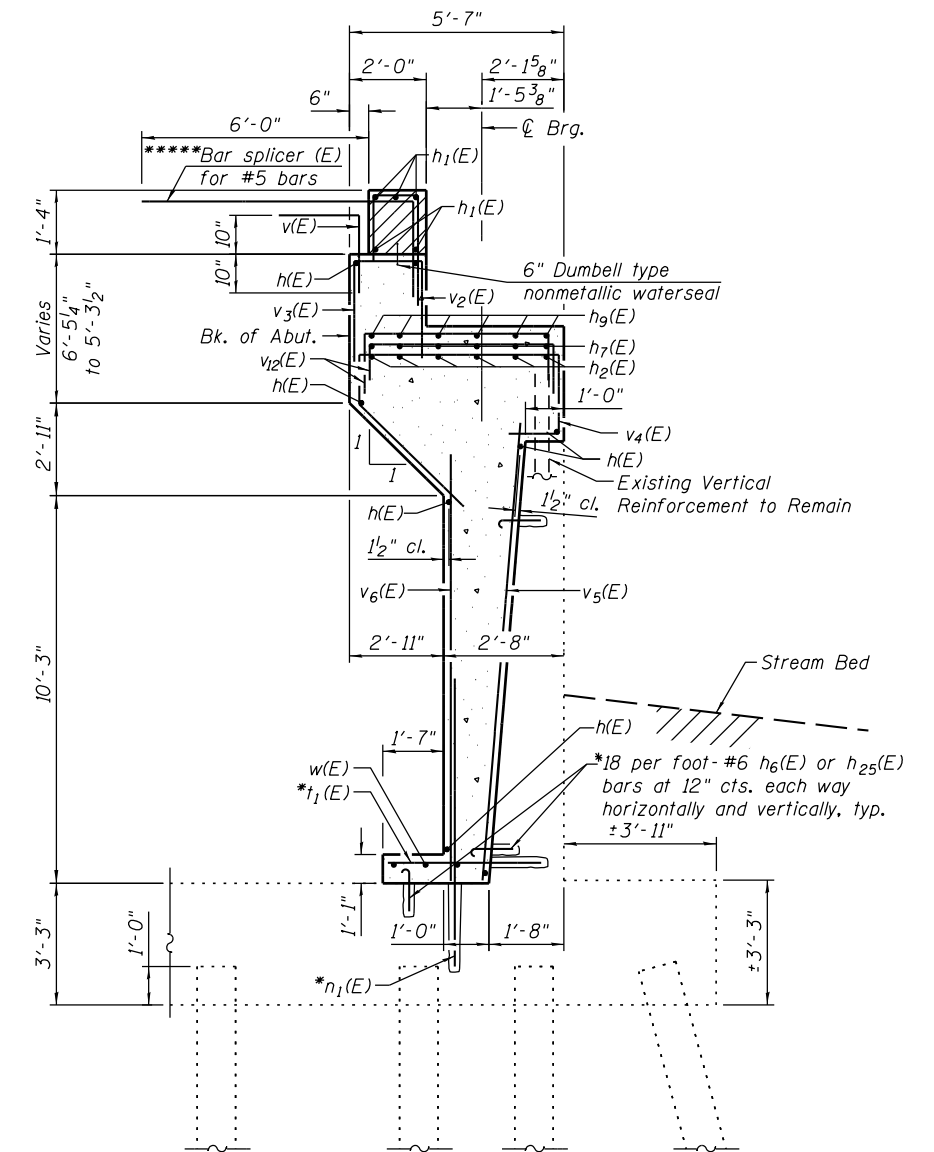

SECTION C-C

FILE NAME = s:\p1\6380--6395\6346\025\micro\Sh\Structural\Plans\0980015-64C17-025-SABUT2.dgn