

When cantilever forming brackets are used, the work shall be done according to Article 503.06(b) of the Standard Specifications, except as modified below and in the details shown on this sheet.

The finishing machine rails shall be placed on the top flange of the exterior beams.

The beams or girders, supporting cantilever forming brackets, shall be tied together at 4 foot intervals.

For Standard construction, or Stage Construction the Hardwood bracing materials shall be placed as shown between webs of beams in each bay.

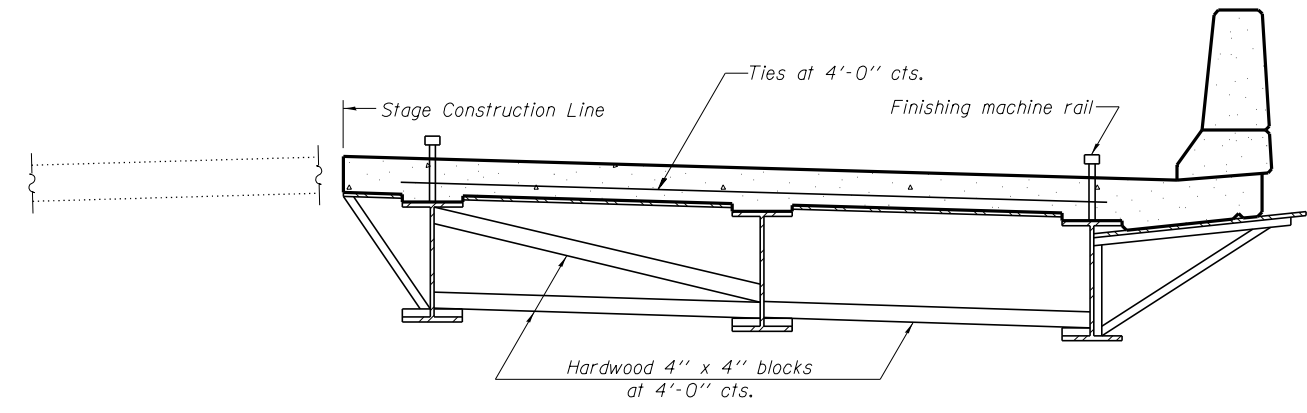

**FORM BRACES FOR
STAGE CONSTRUCTION**

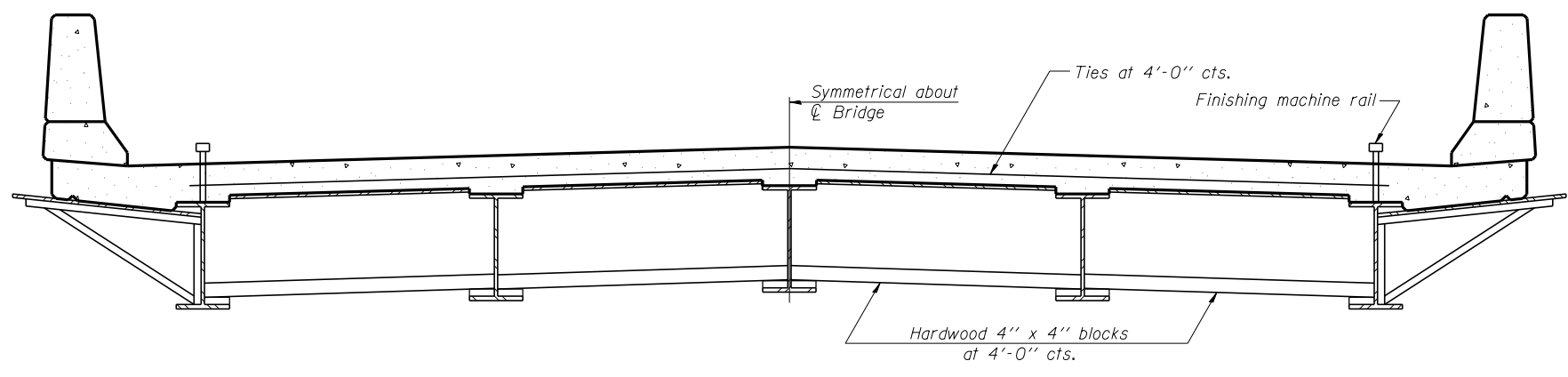

**FORM BRACES FOR
STANDARD CONSTRUCTION**

FILENAME: c:\pawork\spudsa\carpenter\d\8044492\08660140_66A17-024-FormBrackets.dgn

SB-1

7-1-10

BLOOM COMPANIES, LLC
Infrastructure, Innovation and Integrity
600 W. Fulton Street, Suite 701 • Chicago, IL 60661
Phone: (312) 876-9500 Fax: (312) 876-9800

USER NAME = carpenterdj	DESIGNED - BCM	REVISED
	CHECKED - KO	REVISED
PLOT SCALE = N/A	DRAWN - BCM	REVISED
PLOT DATE = 8/1/2014	CHECKED - 7/26/2012	REVISED

**STATE OF ILLINOIS
DEPARTMENT OF TRANSPORTATION**

**CANTILEVER FORMING BRACKETS FOR SUPERSTRUCTURES WITH
W27 BEAMS AND SMALLER**

SHEET NO. S24 OF S26 SHEETS

F.A.P. RTE.	SECTION	COUNTY	TOTAL SHEETS	SHEET NO.
613	(8D-BR) BR	BUREAU	63	46
CONTRACT NO. 66A17			ILLINOIS FED. AID PROJECT	