

WING WALL ELEVATION
Showing Dimensions

End Post shall be poured after bridge parapet is in place. Form top surface to match parapet grade.

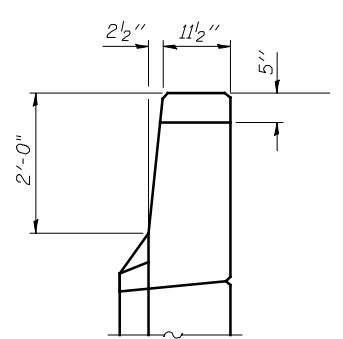

VIEW A-A

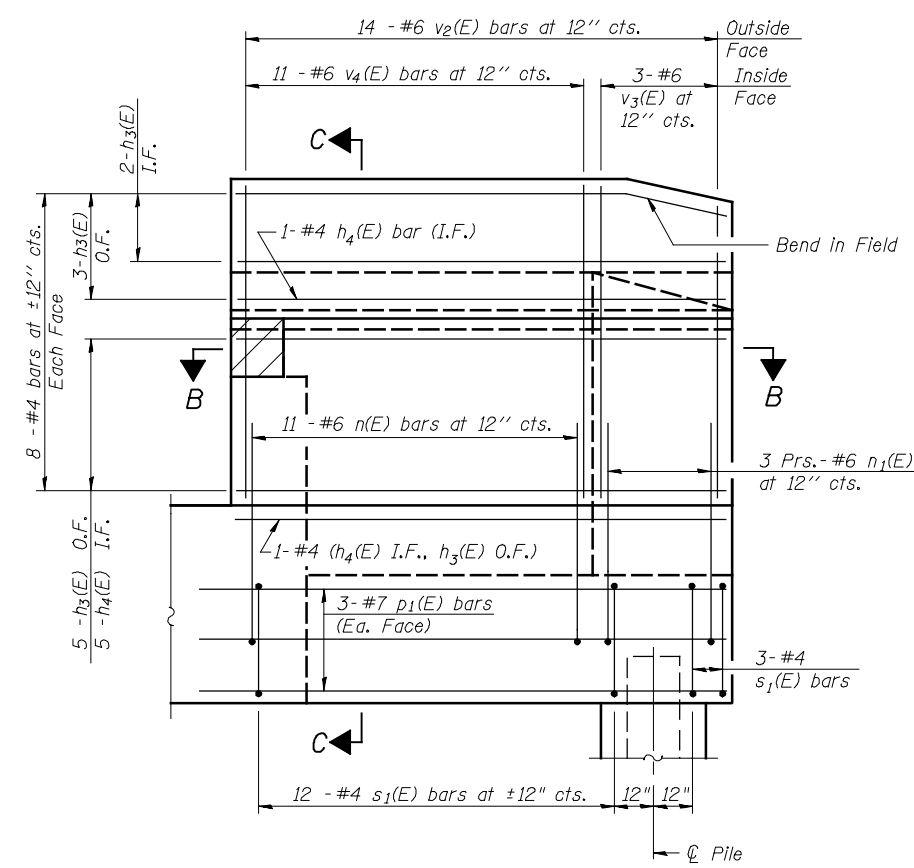

WING WALL ELEVATION
Showing Reinforcement

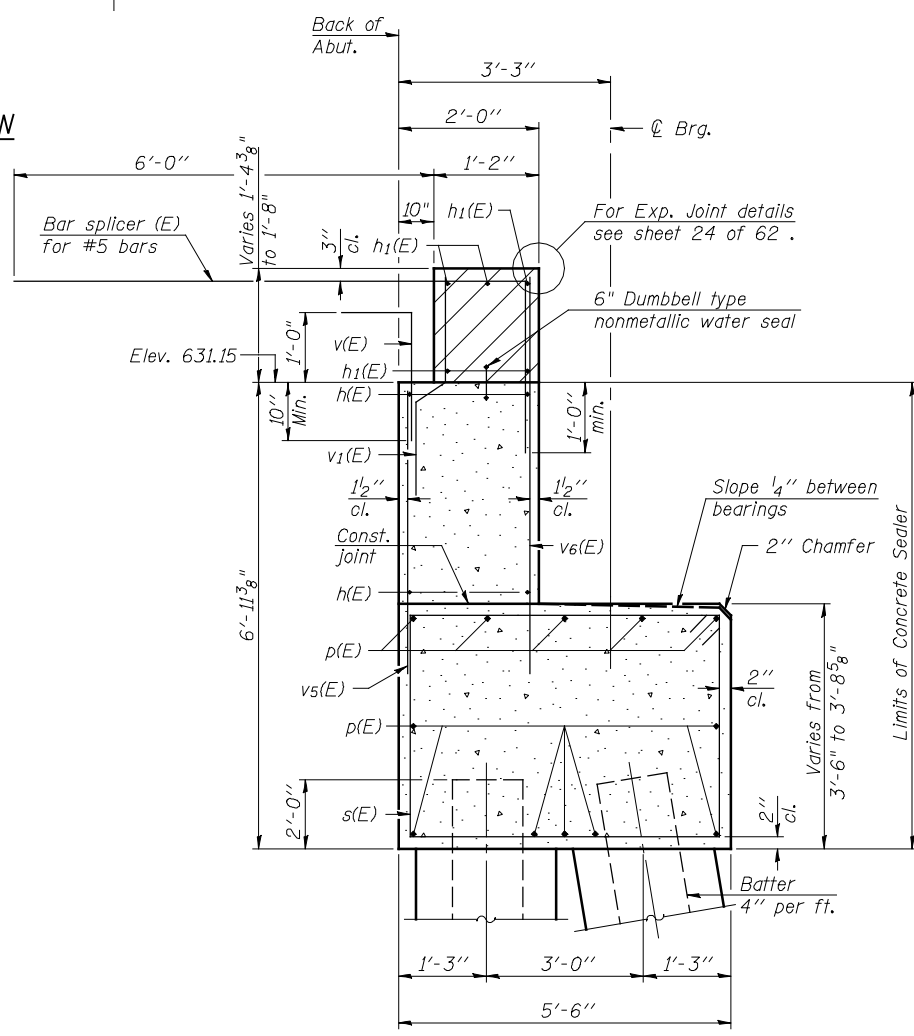

SEC. THRU ABUT.

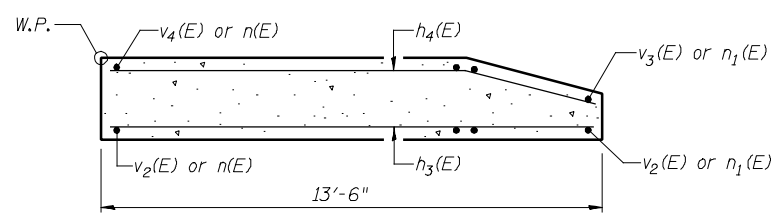

SECTION B-B

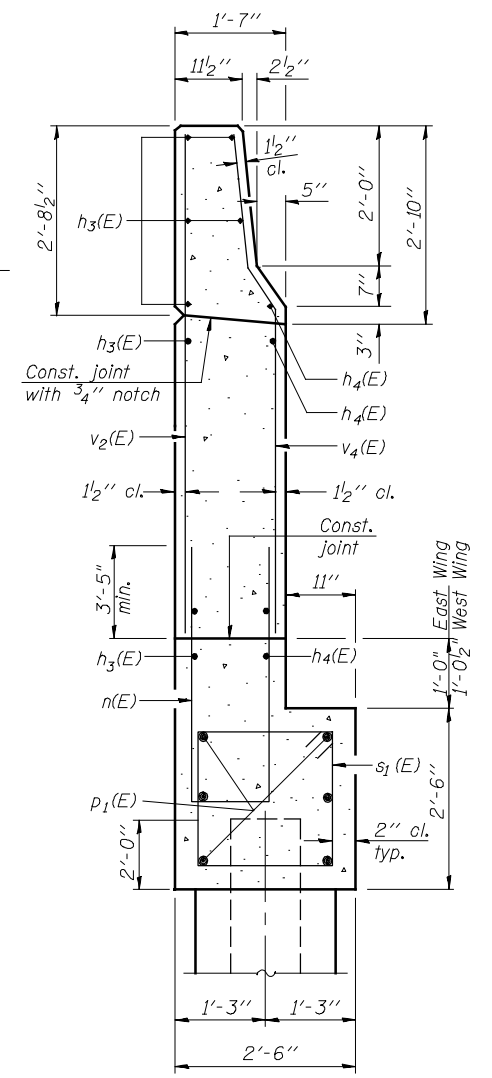

SECTION C-C

Notes:
Hatched area to be poured after superstructure false work has been removed. Quantity of concrete included with Concrete Superstructure.
Space reinforcement in cap to miss anchor bolts.
Pour steps monolithically with cap.
Quantity of concrete in end post included with Concrete Superstructure on sheet 19 of 62.
For Concrete Encasement details, see sheet 53 of 62.