

STATE OF ILLINOIS  
DEPARTMENT OF TRANSPORTATION  
DIVISION OF HIGHWAYS

**PROPOSED  
HIGHWAY PLANS**

F.A.P. ROUTE 685 (IL 9 / IL 94) OVER  
BRANCH OF CAMP CREEK / TILTON CREEK  
SECTION (115)B-2  
PROJECT ACF-0685 (036)  
CULVERT REPLACEMENT  
HANCOCK COUNTY  
C-96-016-12

F.A.P. RTE.	SECTION	COUNTY	TOTAL SHEETS	SHEET NO.
685	(115)B-2	HANCOCK	28	1
FED. ROAD DIST. NO.	ILLINOIS	CONTRACT NO. 72F07		

FOR INDEX OF SHEETS, SEE SHEET NO. 2



ADT = 1100 (2011)  
% SU = 100 (2011)  
% MU = 50 (2011)  
TOWNSHIP: DURHAM  
FUNCTIONAL CLASSIFICATION: MINOR NON-URBAN ARTERIAL

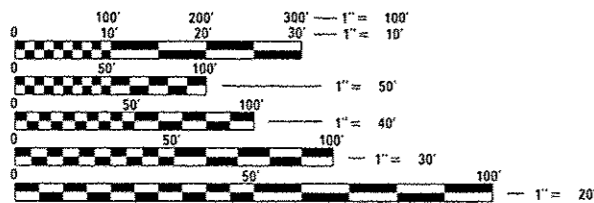

FULL SIZE PLANS HAVE BEEN PREPARED USING STANDARD ENGINEERING SCALES. REDUCED SIZED PLANS WILL NOT CONFORM TO STANDARD SCALES. IN MAKING MEASUREMENTS ON REDUCED PLANS, THE ABOVE SCALES MAY BE USED.

J.U.L.I.E.  
JOINT UTILITY LOCATION INFORMATION FOR EXCAVATION  
1-800-892-0123  
OR 811

SENIOR TEAM ENGINEER: SAL MADONIA 217-782-4760  
TEAM MANAGER: JONATHAN COX 217-782-1378

CONTRACT NO. 72F07

BEGIN PROJECT  
STA 630+79

PROPOSED PRECAST  
TRIPLE BARREL CONCRETE  
BOX CULVERT  
(10'-0"W X 10'-0"H)  
OVER BRANCH OF  
CAMP CREEK / TILTON CREEK  
EX SN 034-0010  
PR SN 034-2528  
E-STA 633+00.54

END PROJECT  
STA. 634+50

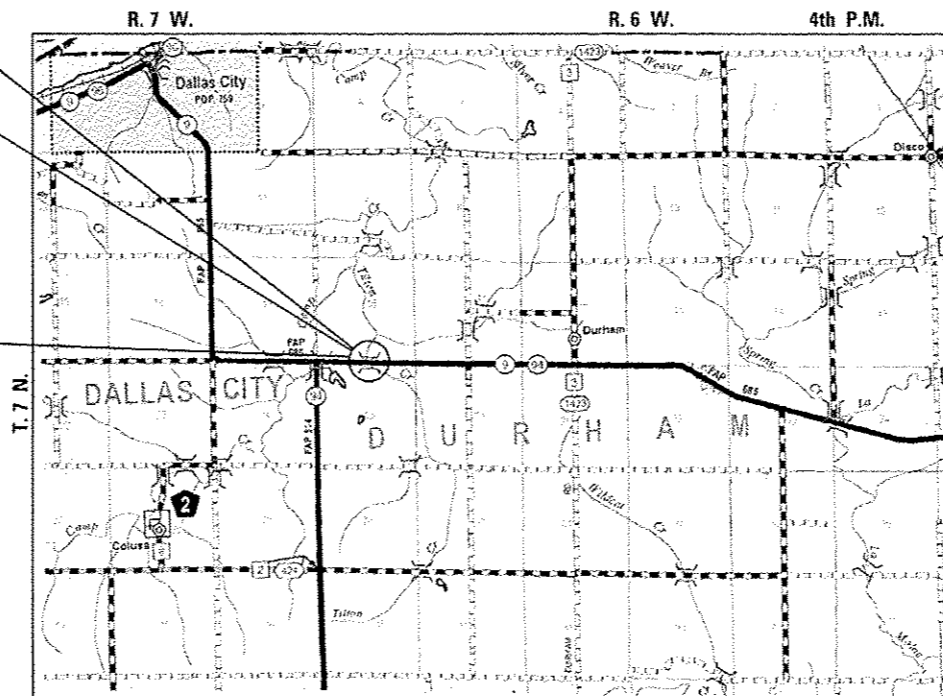

**LOCATION MAP**

GROSS LENGTH OF PROJECT = 371.00 FEET = 0.070 MILES  
NET LENGTH OF PROJECT = 76.00 FEET = 0.014 MILES

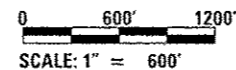

Allen Henderson & Associates, Inc.  
Civil and Structural Engineers Springfield, IL  
62703 Phone: (217)544-8033 IL Design Firm  
No. 184-001907



Christopher P. Kollman 7/29/14  
EXPIRATION: 11/30/2015

STATE OF ILLINOIS  
DEPARTMENT OF TRANSPORTATION  
DIVISION OF HIGHWAYS

SUBMITTED July 31 20 14  
Rign Z Orick  
DEPUTY DIRECTOR OF HIGHWAYS, REGION FOUR ENGINEER

Oct 17 20 14  
John D. Baranzelli P.E.  
acting ENGINEER OF DESIGN AND ENVIRONMENT

Oct 17 20 14  
Omer Osman P.E.  
DIRECTOR OF HIGHWAYS, CHIEF ENGINEER

PRINTED BY THE AUTHORITY  
OF THE STATE OF ILLINOIS

**PROPERTY OWNER ACCESS REQUIREMENT**

ACCESS MUST BE MAINTAINED TO ALL EXISTING PROPERTIES DURING CONSTRUCTION PER ARTICLE 107.09 UNLESS ARRANGEMENTS ARE MADE IN WRITING BY THE CONTRACTOR WITH THE PROPERTY OWNERS WITH A COPY TO THE ENGINEER FOR SHORT-TERM CLOSURES.

**GENERAL NOTES**

- 1.) THE THICKNESS OF HOT-MIX ASPHALT MIXTURES SHOWN ON THE PLANS IS THE NOMINAL THICKNESS. DEVIATIONS FROM THE NOMINAL THICKNESS WILL BE PERMITTED WHEN SUCH DEVIATIONS OCCUR DUE TO IRREGULARITIES IN THE EXISTING SURFACE OR BASE ON WHICH THE BITUMINOUS MIXTURE IS PLACED.
- 2.) EXCEPT AS NOTED IN THE PLANS, PAVEMENT GRADES SHOWN ARE AT THE TOP OF PAVEMENT SURFACES.
- 3.) WHERE SECTION OR SUBSECTION MONUMENTS ARE ENCOUNTERED, THE ENGINEER SHALL BE NOTIFIED BEFORE SUCH MONUMENTS ARE REMOVED. THE CONTRACTOR SHALL PROTECT AND CAREFULLY PRESERVE ALL PROPERTY MARKERS AND MONUMENTS UNTIL THE OWNER OR AN AUTHORIZED SURVEYOR OR AGENT HAS WITNESSED OR OTHERWISE REFERENCED THEIR LOCATION. THE CONTRACTOR WILL BE RESPONSIBLE FOR HAVING AN AUTHORIZED SURVEYOR RE-ESTABLISH ANY SECTION OR SUBSECTION MONUMENTS DESTROYED BY HIS OPERATIONS.
- 4.) SEEDING WILL NOT BE PERMITTED AT ANY TIME WHEN THE GROUND IS FROZEN, WET OR IN AN UNTILLABLE CONDITION. AREAS TO BE SEEDED SHALL BE DETERMINED BY THE ENGINEER AND SEEDED AS SOON AS POSSIBLE. SEEDING SHALL BE DONE ON ALL AREAS THAT ARE DISTURBED BY CONSTRUCTION OPERATIONS AS DIRECTED BY THE ENGINEER. SEEDING SHALL NOT BE PERMITTED AT ANY TIME WHEN THE GROUND IS FROZEN, WET OR IN UNTILLABLE CONDITION. SEEDING SHALL BE PAID FOR ONLY WITHIN THE PROPOSED RIGHT-OF-WAY OR EASEMENT LIMITS. ALL AREAS DISTURBED BY THE CONTRACTOR OUTSIDE THE PROPOSED RIGHT-OF-WAY OR EASEMENT LIMITS SHALL BE SEEDED, AS DIRECTED BY THE ENGINEER, AT THE CONTRACTOR'S EXPENSE.
- 5.) ALL SAW CUTS, NECESSARY TO COMPLETE THE WORK DETAILED IN THESE PLANS, SHALL BE INCLUDED IN THE COST FOR THE VARIOUS PAY ITEMS INVOLVED, THE MINIMUM SAW CUT DEPTH IN THE PAVEMENT SHALL BE 1/2" UNLESS OTHERWISE SPECIFIED IN A DETAIL SHOWN IN THE PLANS.
- 6.) UNLESS DIRECTED BY THE ENGINEER, PAVEMENT MARKING LINES SHALL NOT BE LAID DIRECTLY OVER A LONGITUDINAL CRACK OR JOINT NOR OVER A TAR OR ASPHALT PAINTED LINE. THE EDGE OF A CENTERLINE OR LANE LINE SHALL BE OFFSET A MINIMUM DISTANCE OF 2" FROM A LONGITUDINAL CRACK OR JOINT. EDGE LINES SHALL BE APPROXIMATELY 2" FROM THE EDGE LINE OF PAVEMENT. SEE SECTION 780 OF THE STANDARD SPECIFICATIONS FOR TRAFFIC CONTROL ITEMS.
- 7.) ABANDONED UNDERGROUND UTILITIES THAT CONFLICT WITH CONSTRUCTION SHALL BE DISPOSED OUTSIDE THE LIMITS OF RIGHT OF WAY ACCORDING TO ARTICLE 202.03 OF THE STANDARD SPECIFICATIONS AND AS DIRECTED BY THE ENGINEER. THIS WORK WILL NOT BE PAID FOR SEPERATELY BUT SHALL BE INCLUDED IN THE COST PER CUBIC YARD FOR EARTH EXCAVATION AND NO ADDITIONAL COMPENSATION WILL BE ALLOWED.
- 8.) ANY REFERENCE TO A STANDARD IN THESE PLANS SHALL BE INTERPRETED TO MEAN THE EDITION AS INDICATED BY THE SUBNUMBER LISTED IN THE INDEX OF SHEETS OR THE COPY OF THE STANDARD INCLUDED IN THESE PLANS.
- 9.) IN ADDITION TO THE FIELD SURVEYS, PLAN DIMENSIONS AND DETAILS RELATIVE TO THE EXISTING FACILITIES HAVE BEEN TAKEN FROM EXISTING PLANS AND ARE SUBJECT TO CONSTRUCTION VARIATIONS. IT SHALL BE THE CONTRACTOR'S RESPONSIBILITY TO VERIFY SUCH DIMENSIONS AND DETAILS IN THE FIELD. SUCH VARIATIONS SHALL NOT BE A CAUSE FOR ADDITIONAL COMPENSATION DUE TO CHANGE IN THE SCOPE OF WORK. HOWEVER, THE CONTRACTOR WILL BE PAID FOR THE QUANTITY ACTUALLY FURNISHED AT THE UNIT PRICE BID FOR THE WORK.
- 10.) THE EXISTING ROAD SIGNS THAT INTERFERE WITH CONSTRUCTION WILL BE REMOVED OR RELOCATED AS DIRECTED BY THE ENGINEER. AFTER THE CONSTRUCTION IS COMPLETED, THE CONTRACTOR WILL REPLACE THE SIGNS AS DIRECTED BY THE ENGINEER. THIS WORK WILL NOT BE PAID FOR SEPARATELY BUT SHALL BE CONSIDERED INCLUDED IN THE CONTRACT, AND NO COMPENSATION WILL BE ALLOWED.

- 11.) THE LOCATION OF ALL UTILITIES ARE BASED ON INFORMATION PROVIDED BY OTHERS AND IS INTENDED TO BE APPROXIMATE. IT SHALL BE THE CONTRACTOR'S RESPONSIBILITY TO COORDINATE HIS CONSTRUCTION ACTIVITIES WITH THE VARIOUS UTILITY OWNERS. ALL POTENTIAL CONFLICTS SHALL BE INVESTIGATED AND REMEDIAL ACTION TAKEN PRIOR TO INTERRUPTION OF THE CONTRACTOR'S PROGRESS. ALL UTILITY FACILITIES THAT REQUIRE RELOCATION WITHIN STATE RIGHT OF WAY SHALL BE COMPLETED BY THE UTILITY COMPANY UNLESS OTHERWISE SHOWN ON THE PLANS.
- 12.) THE CONTRACTOR SHALL BE RESPONSIBLE FOR PROTECTING UTILITY PROPERTY FROM CONSTRUCTION OPERATIONS AS OUTLINED IN ARTICLE 107.31 OF THE STANDARD SPECIFICATIONS. THE J.U.L.I.E. NUMBER IS 800-892-0123. A MINIMUM OF FORTY-EIGHT HOURS ADVANCE NOTICE IS REQUIRED.
- 13.) ALL ELEVATIONS SHOWN ON THE PLANS ARE BASED ON U.S.G.S. MEAN SEA LEVEL DATUM. ALL STATION AND OFFSET REFERENCES ARE TO THE ROADWAY CENTERLINE UNLESS OTHERWISE NOTED. THE STATE PLANE COORDINATE SYSTEM HAS BEEN USED FOR THE HORIZONTAL CONTROL.
- 14.) THE DISTRICT BUREAU OF OPERATIONS SHALL BE NOTIFIED AT LEAST 21 DAYS PRIOR TO CLOSING THE ROAD TO TRAFFIC (PH: 217-785-5312).
- 15.) THE DISTRICT BUREAU OF OPERATIONS SHALL BE NOTIFIED AT LEAST 14 DAYS PRIOR TO PLACEMENT OF FINAL PAVEMENT MARKINGS (PH: 217-785-5312)
- 16.) EXISTING PAVEMENT DAMAGED DUE TO THE CONTRACTOR'S OPERATIONS, AND NOT OTHERWISE NECESSARY TO REPLACE, SHALL BE REPLACED AT THE EXPENSE OF THE CONTRACTOR.
- 17.) ONLY THOSE TREES LISTED IN THE TREE REMOVAL SCHEDULE SHALL BE REMOVED. THE CONTRACTOR SHALL PROTECT ALL REMAINING TREES, PLANTS, AND WETLANDS FROM DAMAGE. ALL TREES AND STUMPS INDICATED ON THE PLANS FOR REMOVAL SHALL BE REMOVED AND DISPOSED OF BY THE CONTRACTOR.
- 18.) ALL OPENINGS IN PRECAST STRUCTURES, INCLUDING BOX CULVERTS, SHALL BE PRECAST TO THE PROPER SIZE. THIS INCLUDES OPENINGS FOR PIPE STRUCTURES, MANHOLE OPENINGS AND OPENINGS FOR PIPE UNDERDRAINS. COSTS FOR THESE OPENINGS AND THE CONNECTIONS SHALL BE CONSIDERED INCLUDED IN THE VARIOUS PAY ITEMS FOR THE STRUCTURES INVOLVED.

THE FOLLOWING RATES OF APPLICATION HAVE BEEN USED TO CALCULATE THE PLAN QUANTITIES:

HOT-MIX ASPHALT MATERIALS (PRIME COAT)	0.05 LBS./SQ. FT. (ON PAVEMENT)
HOT-MIX ASPHALT MATERIALS (PRIME COAT)	0.025 LBS./SQ. FT. (ON AGG)
HOT-MIX ASPHALT SURFACE / BINDER	0.056 TON/SQ. YD. PER 1"
AGGREGATE MATERIAL	1.90 TON/CU. YD.
RIPRAP	1.5 TON/CU. YD.
NITROGEN FERTILIZER NUTRIENT	90 LBS./ACRE
PHOSPHOROUS FERTILIZER NUTRIENT	90 LBS./ACRE
POTASSIUM FERTILIZER NUTRIENT	90 LBS./ACRE
AGGREGATE PRIME COAT	0.002 TON/SQ. YD.
AGRICULTURAL GROUND LIMESTONE	2.0 TON/ACRE
ROCKFILL - FOUNDATION	1.89 TON/CU. YD.

**COMMITMENTS**

- 1.) THE RESIDENT ENGINEER SHALL CONTACT STUDIES AND PLANS CONCERNING ANY MAJOR PLAN CHANGE. TO MAKE SURE NO PREVIOUS COMMENTS (NOT LISTED) WERE MADE AFFECTING THE DESIGN AND ALLOW AN IMPROVED DESIGN FOR FUTURE PROJECTS.

**INDEX OF SHEETS**

1	TITLE SHEET
2	GENERAL NOTES & MIXTURE REQUIREMENTS
3 - 5	SUMMARY OF QUANTITIES
6 - 7	SCHEDULE OF QUANTITIES
8 - 10	TYPICAL ROADWAY SECTIONS
11	PLAN
12	PROFILE
13	ROAD CLOSED SIGNING
14	EROSION CONTROL PLAN
15 - 20	CULVERT DETAILS
21 - 28	CROSS SECTIONS

**LIST OF ILLINOIS DOT HIGHWAY STANDARDS**

000001-06	701306-03
001006	701311-03
280001-07	701901-03
515001-03	720006-04
666001-01	728001-01
701001-02	780001-04
701006-05	781001-03
701011-04	BLR 21-9
701201-04	BLR 22-7
701301-04	

**MIXTURE REQUIREMENTS**

MIXTURE USE(S)	HOT-MIX ASPHALT BASE COURSE	HOT-MIX ASPHALT SURFACE COURSE
AC/PG	PG 64-22	PG 64-22
DESIGN AIR VOIDS	4.0% @ N DESIGN = 50	4.0% @ N DESIGN = 50
MIXTURE COMPOSITION	IL 19.0 or IL 19.0CB	IL 9.5
FRICTION AGGREGATE	N/A	MIX C
	OC/OA	OC/OA

**UTILITIES**

MR. JAY HARRISON  
MCDONOUGH TELEPHONE COOPERATIVE  
210 N. COAL ST. P.O. BOX 359  
COLCHESTER, ILLINOIS 62326  
PHONE: (309) 776-3211

<b>DISTRICT SIX</b>	
EXAMINED	<u>July 18<sup>th</sup></u> 20 <u>14</u>
	<i>John C. Wenzel</i>
OPERATIONS ENGINEER	
EXAMINED	<u>July 14</u> 20 <u>14</u>
	<i>Ron Archambeau</i>
PROJECT IMPLEMENTATION ENGINEER	
EXAMINED	<u>July 11</u> 20 <u>14</u>
	<i>Jeff P. M...</i>
PROGRAM DEVELOPMENT ENGINEER	

REV.

CODE	ITEM	UNIT	TOTAL QUANTITY	CONSTRUCTION CODE	
				F. A. P. 685 80% FEDERAL 20% STATE	F. A. P. 685 80% FEDERAL 20% STATE
				ROADWAY 0004	BOX CULVERT 0011
20100500	TREE REMOVAL, ACRES	ACRE	0.6	0.6	
20200100	EARTH EXCAVATION	CU YD	1,761	1,761	
25000200	SEEDING, CLASS 2	ACRE	0.9	0.9	
25000400	NITROGEN FERTILIZER NUTRIENT	POUND	81	81	
25000500	PHOSPHORUS FERTILIZER NUTRIENT	POUND	81	81	
25000600	POTASSIUM FERTILIZER NUTRIENT	POUND	81	81	
25000700	AGRICULTURAL GROUND LIMESTONE	TON	1.8	1.8	
25100115	MULCH, METHOD 2	ACRE	0.9	0.9	
28000200	EARTH EXCAVATION FOR EROSION CONTROL	CU YD	48	48	
28000250	TEMPORARY EROSION CONTROL SEEDING	POUND	100	100	
28000400	PERIMETER EROSION BARRIER	FOOT	450	450	
28001000	AGGREGATE ( EROSION CONTROL )	TON	45	45	
28100807	STONE DUMPED RIPRAP, CLASS A4	TON	1,461	1,461	
28200200	FILTER FABRIC	SQ YD	1,996	1,996	

CODE	ITEM	UNIT	TOTAL QUANTITY	CONSTRUCTION CODE	
				F. A. P. 685 80% FEDERAL 20% STATE	F. A. P. 685 80% FEDERAL 20% STATE
				ROADWAY 0004	BOX CULVERT 0011
35501322	HOT-MIX ASPHALT BASE COURSE, 9 1/2"	SO YD	220	220	
40603310	HOT-MIX ASPHALT SURFACE COURSE, MIX "C", N50	TON	19	19	
44000100	PAVEMENT REMOVAL	SO YD	137	137	
48102100	AGGREGATE WEDGE SHOULDER, TYPE B	TON	45	45	
50100100	REMOVAL OF EXISTING STRUCTURES	EACH	1		1
51500100	NAME PLATES	EACH	1		1
54001001	BOX CULVERT END SECTIONS, CULVERT NO. 1	EACH	2		2
54011010	PRECAST CONCRETE BOX CULVERTS 10' X 10'	FOOT	249		249
63200310	GUARDRAIL REMOVAL	FOOT	857	857	
66600105	FURNISHING AND ERECTING RIGHT OF WAY MARKERS	EACH	11	11	
66700305	PERMANENT SURVEY MARKERS, TYPE II	EACH	1	1	
67000400	ENGINEER'S FIELD OFFICE, TYPE A	CAL MO	6	6	
67100100	MOBILIZATION	L SUM	1	1	
70100450	TRAFFIC CONTROL AND PROTECTION, STANDARD 701201	L SUM	1	1	

FILE NAME *	USER NAME * USER*	DESIGNED -	REVISED -	 <b>Allen Henderson &amp; Associates, Inc.</b> Civil and Structural Engineers Springfield, IL. 62703 Phone: (217)544-8033 IL Design Firm No. 184-001907	<b>SUMMARY OF QUANTITIES</b>			F.A.P. RTE.	SECTION	COUNTY	TOTAL SHEETS	SHEET NO.
*FILE#	DRAWN -	REVISED -	685					(115)B-2	HANCOCK	28	4	
PLOT SCALE * #SCALE*	CHECKED -	REVISED -	SCALE:		SHEET NO. 2 OF 3 SHEETS	STA.	TO STA.	FED. ROAD DIST. NO.	ILLINOIS FED. AID PROJECT	CONTRACT NO. 72F07		
PLOT DATE * #DATE*	DATE -	REVISED -										

CODE	ITEM	UNIT	TOTAL QUANTITY	CONSTRUCTION CODE	
				F. A. P. 685 80% FEDERAL 20% STATE	F. A. P. 685 80% FEDERAL 20% STATE
				ROADWAY 0004	BOX CULVERT 0011
70100460	TRAFFIC CONTROL AND PROTECTION, STANDARD 701306	L SUM	1	1	
70101830	TRAFFIC CONTROL AND PROTECTION, STANDARD BLR 21	L SUM	1	1	
70101835	TRAFFIC CONTROL AND PROTECTION, STANDARD BLR 22	L SUM	1	1	
70106800	CHANGEABLE MESSAGE SIGN	CAL MO	6	6	
70300100	SHORT TERM PAVEMENT MARKING	FOOT	24	24	
70300230	TEMPORARY PAVEMENT MARKING - LINE 5"	FOOT	248	248	
70301000	WORK ZONE PAVEMENT MARKING REMOVAL	SQ FT	105	105	
* 78001120	PAINT PAVEMENT MARKING - LINE 5"	FOOT	248	248	
* 78100100	RAISED REFLECTIVE PAVEMENT MARKER	EACH	2	2	
78300200	RAISED REFLECTIVE PAVEMENT MARKER REMOVAL	EACH	2	2	
Z0013798	CONSTRUCTION LAYOUT	L SUM	1	1	
Z0016702	DETOUR SIGNING	L SUM	1	1	
Z0023602	GRANULAR CULVERT BACKFILL	CU YD	684		684
* Z0054517	ROCK FILL - FOUNDATION	TON	493		493

\* SPECIALTY ITEM

FILE NAME *	USER NAME * #USER*	DESIGNED -	REVISED -	 <b>Allen Henderson &amp; Associates, Inc.</b> Civil and Structural Engineers Springfield, IL. 62703 Phone: (217)544-8033 IL Design Firm No. 184-001907	SUMMARY OF QUANTITIES		F.A.P. RTE.	SECTION	COUNTY	TOTAL SHEETS	SHEET NO.
#FILE#	DRAWN -	REVISED -	685				(115)B-2	HANCOCK	28	5	
PLOT SCALE * #SCALE*	CHECKED -	REVISED -	SCALE:		SHEET NO. 3 OF 3 SHEETS	STA.	TO STA.	FED. ROAD DIST. NO. ILLINOIS FED. AID PROJECT			
PLOT DATE * #DATE*	DATE -	REVISED -	CONTRACT NO. 72F07								

CULVERT SCHEDULE								
LOCATION	PRECAST BOX	BOX CULVERT	GRANULAR	ROCKFILL	SKEW	DESIGN FILL (FT.)		PGE BACKFILL
	CULVERTS					END SECTIONS	CULVERT	
	10' X 10'	EACH	CU. YD.	TON		(MINIMUM)	FEET	
STA. 632+82.79 TO STA. 633+18.29 43' LT. & RT.	249	2	684	493	0	4.56	4.95	YES
TOTAL	249	2	684	493	0	4.56	4.95	

STONE DUMPED RIPRAP, CLASS A4 & FILTER FABRIC		
LOCATION	STONE DUMPED	FILTER FABRIC
	RIPRAP	SO. YD.
STA. 632+00 TO STA. 634+50 LT.	843	1,137
STA. 630+79 TO STA. 634+00 RT.	618	859
TOTAL	1,461	1,996

GUARDRAIL REMOVAL	
LOCATION	QUANTITY
	FOOT
STA. 631+19 TO STA. 635+79 LT.	460
STA. 630+85 TO STA. 634+82 RT.	397
TOTAL	857

PAVEMENT MARKING							
LOCATION	PAINT PAVEMENT MARKING - LINE 5"			TEMPORARY PAVEMENT MARKING - LINE 5"			SHORT TERM
							PAVEMENT
	SOLID	SOLID	SKIP DASH	SOLID	SOLID	SKIP DASH	SOLID
WHITE	YELLOW	YELLOW	WHITE	YELLOW	YELLOW	WHITE	MARKING
FOOT	FOOT	FOOT	FOOT	FOOT	FOOT	FOOT	FOOT
STA. 632+62 TO STA. 633+38 LT.	76			76			8
STA. 632+62 TO STA. 633+38 C		76	20 RT.		76	20 RT.	8
STA. 632+62 TO STA. 633+38 RT.	76			76			8
SUBTOTAL	152	76	20	152	76	20	
TOTAL	248			248			24

AGGREGATE WEDGE SHOULDER, TYPE B	
LOCATION	QUANTITY
	TON
STA. 632+00 TO STA. 634+50 LT.	18
STA. 630+79 TO STA. 634+50 RT.	27
TOTAL	45

PAVEMENT REMOVAL	
LOCATION	QUANTITY
	SO. YD.
STA. 632+62 TO STA. 632+86	70
STA. 633+15 TO STA. 633+38	67
TOTAL	137

FURNISHING AND ERECTING RIGHT OF WAY MARKERS	
LOCATION	QUANTITY
	EACH
STA. 632+00 60' LT.	1
STA. 632+50 150' LT.	1
STA. 633+50 150' LT.	1
STA. 634+50 40' LT.	1
STA. 630+37.46 40' RT.	1
STA. 630+38.29 80' RT.	1
STA. 632+50 80' & 110' RT.	2
STA. 633+50 80' & 110' RT.	2
STA. 634+50 40' RT.	1
TOTAL	11

TREE REMOVAL	
LOCATION	QUANTITY
	ACRE
STA. 631+18 TO STA. 633+10 LT. TO ROW	0.18
STA. 632+91 TO STA. 634+50 LT. TO ROW	0.26
STA. 632+50 TO STA. 632+95 RT. TO ROW	0.07
STA. 633+08 TO STA. 633+50 RT. TO ROW	0.07
TOTAL	0.58

SAY 0.6 ACRE

EARTHWORK				
LOCATION	EARTH	EARTH	EMBANKMENT	EARTHWORK
	EXCAVATION	EXCAVATION		BALANCE
	ADJUSTED FOR	ADJUSTED FOR		WASTE (+) OR
	SHRINKAGE	SHRINKAGE		SHORTAGE (-)
	CU. YD.	CU. YD.	CU. YD.	CU. YD.
STA. 630+79 TO STA. 631+00	3	2	1	1
STA. 631+00 TO STA. 631+50	14	10	7	3
STA. 631+50 TO STA. 632+00	52	39	17	22
STA. 632+00 TO STA. 632+50	135	101	72	29
STA. 632+50 TO STA. 632+80	157	118	218	-100
STA. 632+80 TO STA. 633+00	68	51	156	-105
STA. 633+00 TO STA. 633+20	346	260	109	151
STA. 633+20 TO STA. 633+50	629	472	119	353
STA. 633+50 TO STA. 634+00	264	198	26	172
STA. 634+00 TO STA. 634+50	93	70	14	56
TOTAL	1,761	1,321	739	•582

\*NO FURNISHED EXCAVATION WILL BE REQUIRED. THE COST FOR THE REMOVAL OF EXCESS EARTH AND CHANNEL EXCAVATION SHALL BE INCLUDED IN THE COST OF EARTH EXCAVATION.

WORK ZONE PAVEMENT MARKING REMOVAL	
LOCATION	QUANTITY
	SO FT
STA. 632+62 TO STA. 633+38 LT.	32
STA. 632+62 TO STA. 633+38 RT. (SOLID)	32
STA. 632+62 TO STA. 633+38 C (SKIP DASH)	9
STA. 632+62 TO STA. 633+38 RT.	32
TOTAL	105

RAISED REFLECTIVE PAVEMENT MARKER REMOVAL	
LOCATION	QUANTITY
	EACH
STA. 632+60	1
STA. 633+40	1
TOTAL	2

HOT MIX ASPHALT SCHEDULE		
LOCATION	HMA BASE	HMA SURFACE
	COURSE 9 1/2"	COURSE, MIX C, N50
	SO. YD.	TON
STA. 632+62 TO STA. 633+38	220	19
TOTAL	220	19

PERMANENT SURVEY MARKER, TYPE II	
LOCATION	QUANTITY
	EACH
STA. 630+35.80, 39.52' LT.	1
TOTAL	1

RAISED REFLECTIVE PAVEMENT MARKER	
LOCATION	TWO WAY
	AMBER
	EACH
STA. 632+60	1
STA. 633+40	1
TOTAL	2

REMOVAL OF EXISTING STRUCTURES	
LOCATION	QUANTITY
	EACH
STA. 632+85.5 TO STA. 633+15.5	1
TOTAL	1

TREE REMOVAL, ACRES	
LOCATION	QUANTITY
	ACRE
STA. 631+18 TO STA. 634+50 LT.	0.44
STA. 632+50 TO STA. 633+50 RT.	0.14
TOTAL	0.58

SAY 0.6 ACRE

TEMPORARY EROSION CONTROL			
LOCATION	TEMPORARY EROSION CONTROL SEEDING	PERIMETER EROSION BARRIER	AGGREGATE (EROSION CONTROL)
	POUND	FOOT	TON
STA. 630+50 TO STA. 634+50	100		
STA. 632+00 TO STA. 634+50 LT.		322	
STA. 632+50 TO STA. 633+50 RT.		128	
STA. 632+50 55' LT. & 60' RT.			10
STA. 632+70 60' LT. & 63' RT.			10
STA. 633+10 135' LT.			5
STA. 633+35 63' LT. & 60' RT.			10
STA. 633+50 52' LT. & 53' RT.			10
TOTAL	100	450	45

PERMANENT SEEDING						
LOCATION	SEEDING CLASS 2	NITROGEN FERT. NUT.	PHOSPHORUS FERT. NUT.	POTASSIUM FERT. NUT.	MULCH METHOD 2	AGRICULTURAL GROUND LIMESTONE
	ACRE	POUND	POUND	POUND	ACRE	TON
STA. 630+50 TO STA. 634+50	0.9	81	81	81	0.9	1.8
TOTAL	0.9	81	81	81	0.9	1.8

EARTH EXCAVATION FOR EROSION CONTROL	
LOCATION	QUANTITY CU. YD.
STA. 632+50 LT.	12
STA. 632+50 RT.	12
STA. 633+50 LT.	12
STA. 633+50 RT.	12
TOTAL	48

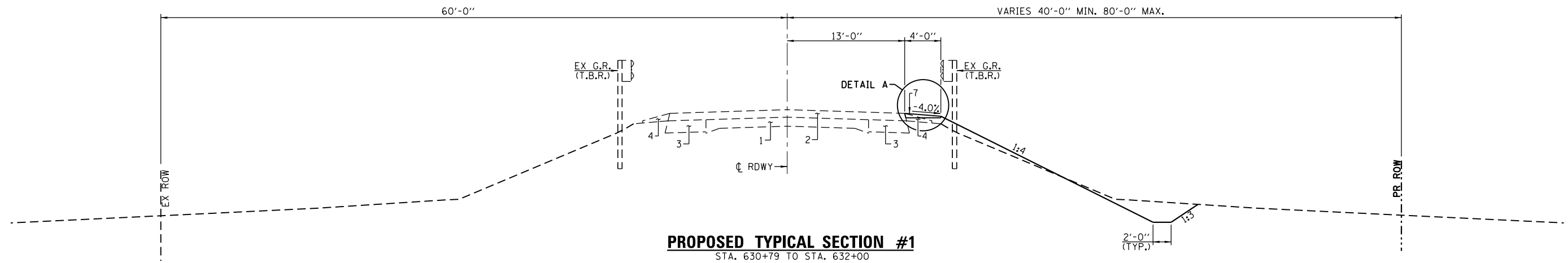

**PROPOSED TYPICAL SECTION #1**  
 STA. 630+79 TO STA. 632+00

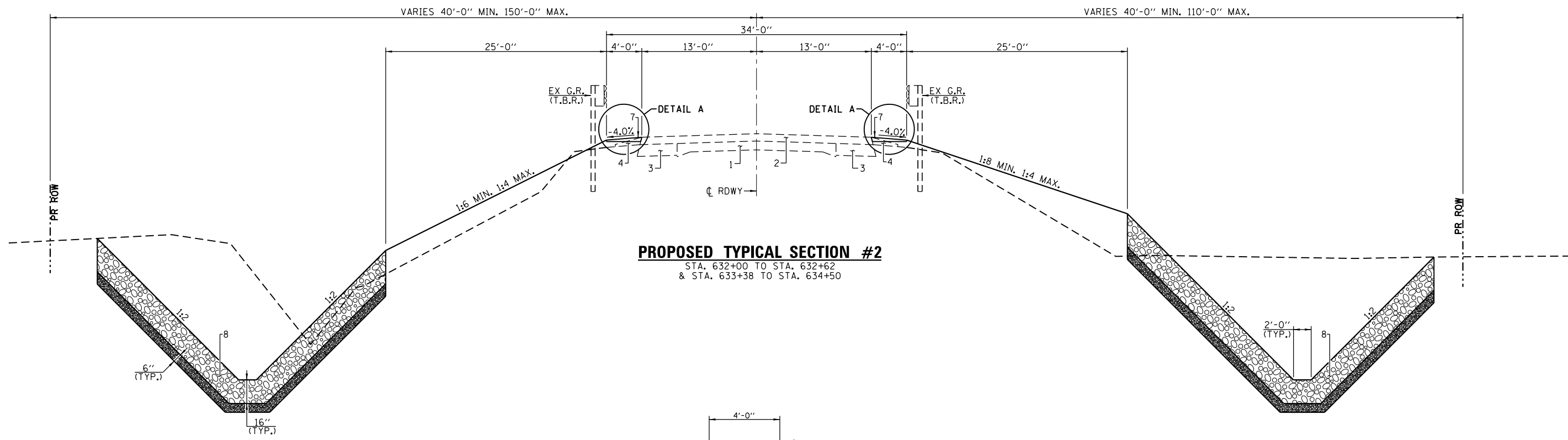

**PROPOSED TYPICAL SECTION #2**  
 STA. 632+00 TO STA. 632+62  
 & STA. 633+38 TO STA. 634+50

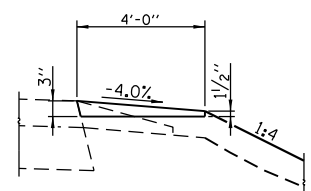

**DETAIL A**

NOTE: SEE CROSS SECTIONS FOR ADDITIONAL SLOPE DETAILS

**PAVEMENT LEGEND**

1. EX 9"-6"-9" PCC PVMT
2. EX BIT SURF OVERLAYS
3. EX CONC BASE CRSE WIDENING
4. EX AGG SHLD
5. PR PAVEMENT MARKING-LINES 5"
6. PR HMA BASE COURSE 9 1/2"
7. PR AGG WEDGE TYPE B
8. PR STONE DUMPED RIPRAP CLASS A4 WITH BEDDING & FILTER FABRIC
9. PR HMA SURFACE COURSE, MIX C, N50 1 1/2"

USER NAME = *USER*	DESIGNED -	REVISED -	 <b>Allen Henderson &amp; Associates, Inc.</b> Civil and Structural Engineers Springfield, IL 62703 Phone: (217)544-8033 IL Design Firm No. 184-001907	<b>TYPICAL ROADWAY SECTIONS</b>			F.A.P. RTE.	SECTION	COUNTY	TOTAL SHEETS	SHEET NO.
DRAWN -	REVISIED -	REVISIED -		SCALE: NONE	SHEET NO. 1 OF 3 SHEETS	STA. 630+00.00 TO STA. 634+50.00	685	(115)B-2	HANCOCK	28	8
PLOT SCALE = *SCALE*	CHECKED -	REVISIED -					<b>CONTRACT NO. 72F07</b>				
PLOT DATE = *DATE*	DATE -	REVISIED -					FED. ROAD DIST. NO. ILLINOIS FED. AID PROJECT				



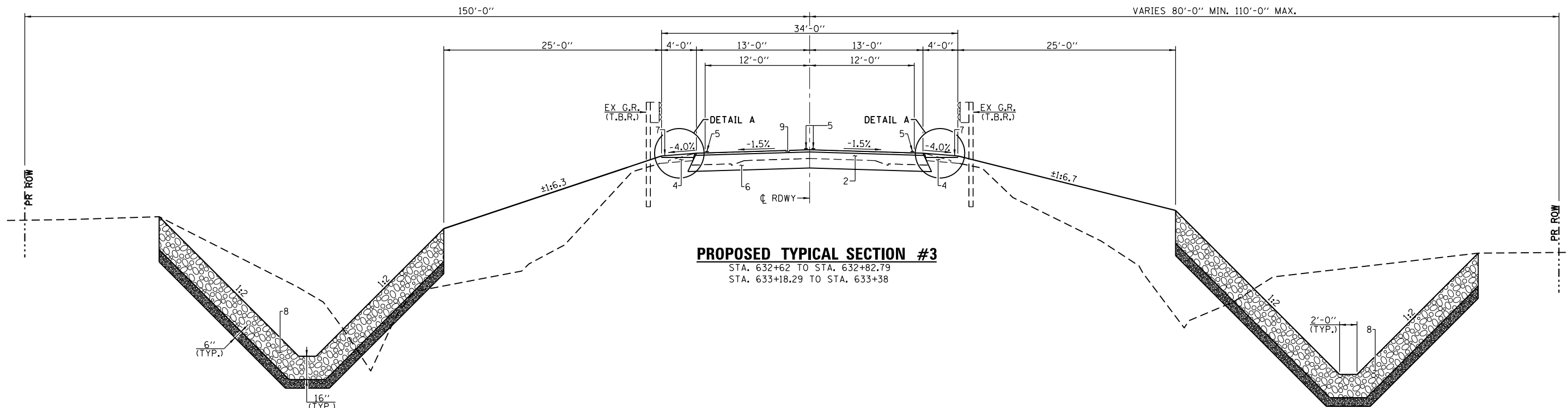

**PROPOSED TYPICAL SECTION #3**  
 STA. 632+62 TO STA. 632+82.79  
 STA. 633+18.29 TO STA. 633+38

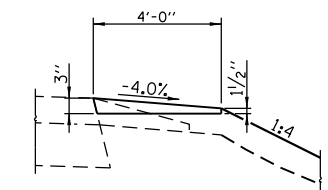

**DETAIL A**

**PAVEMENT LEGEND**

1. EX 9"-6"-9" PCC PVMT
2. EX BIT SURF OVERLAYS
3. EX CONC BASE CRSE WIDENING
4. EX AGG SHLD
5. PR PAVEMENT MARKING-LINES 5"
6. PR HMA BASE COURSE 9 1/2"
7. PR AGG WEDGE TYPE B
8. PR STONE DUMPED RIPRAP CLASS A4 WITH BEDDING & FILTER FABRIC
9. PR HMA SURFACE COURSE, MIX C, N50 1 1/2"

USER NAME = *USER*	DESIGNED -	REVISED -	 <b>Allen Henderson &amp; Associates, Inc.</b> Civil and Structural Engineers Springfield, IL 62703 Phone: (217)544-8033 IL Design Firm No. 184-001907	<b>TYPICAL ROADWAY SECTIONS</b>			F.A.P. RTE.	SECTION	COUNTY	TOTAL SHEETS	SHEET NO.
PLOT SCALE = *SCALE*	DRAWN -	REVISED -		SCALE: NONE	SHEET NO. 2 OF 3 SHEETS	STA. 632+50.00 TO STA. 633+50.00	685	(115)B-2	HANCOCK	28	9
PLOT DATE = *DATE*	CHECKED -	REVISED -					CONTRACT NO. 72F07				
	DATE -	REVISED -					FED. ROAD DIST. NO. ILLINOIS FED. AID PROJECT				

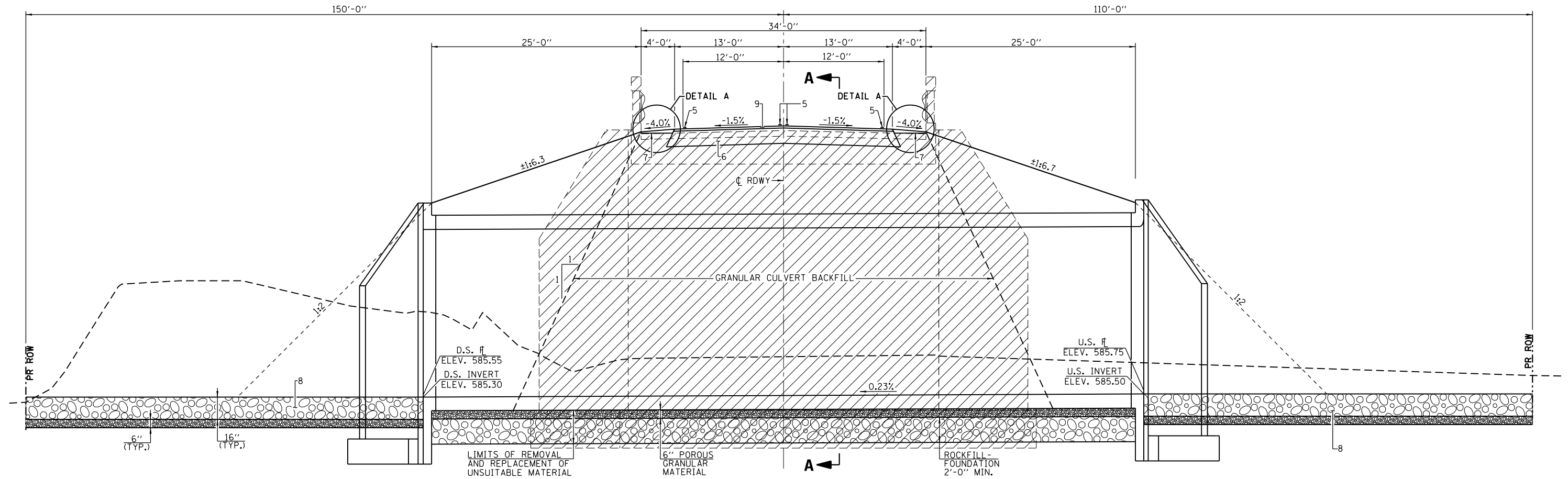

**PROPOSED TYPICAL SECTION #3**  
 STA. 632+82.79 TO STA. 633+18.29

- EXISTING STRUCTURE AND PAVEMENT REMOVAL

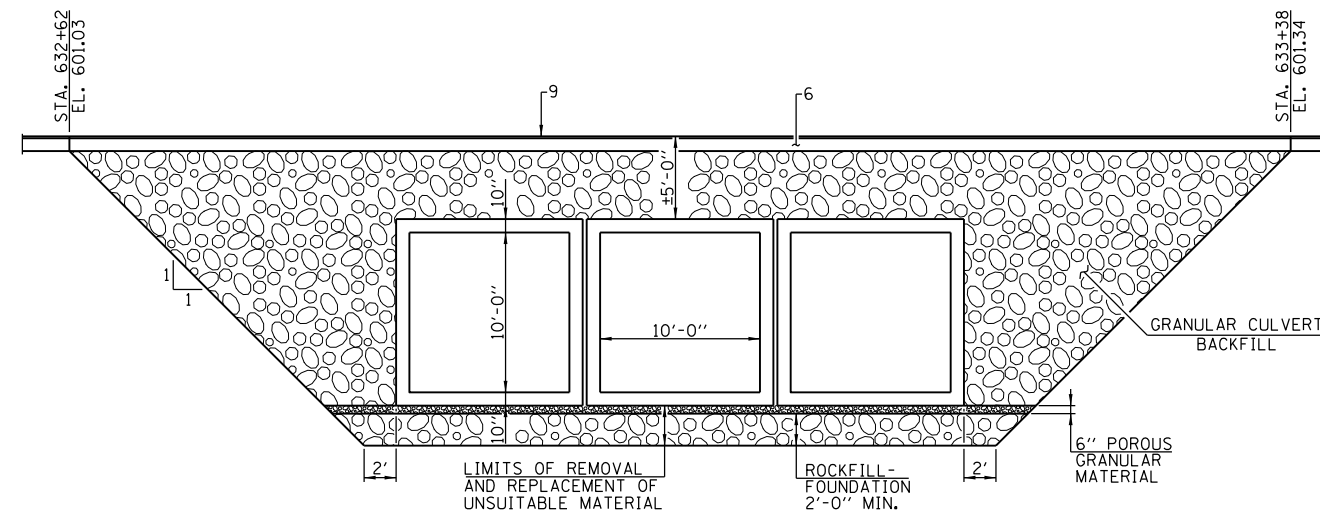

**SECTION A-A**

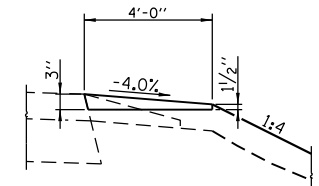

**DETAIL A**

**PAVEMENT LEGEND**

1. EX 9"-6"-9" PCC PVMT
2. EX BIT SURF OVERLAYS
3. EX CONC BASE CRSE WIDENING
4. EX AGG SHLD
5. PR PAVEMENT MARKING-LINES 5"
6. PR HMA BASE COURSE 9 1/2"
7. PR AGG WEDGE TYPE B
8. PR STONE DUMPED RIPRAP CLASS A4 WITH BEDDING & FILTER FABRIC
9. PR HMA SURFACE COURSE, MIX C, N50 1 1/2"

USER NAME = *USER*	DESIGNED -	REVISED -
	DRAWN -	REVISED -
PLOT SCALE = *SCALE*	CHECKED -	REVISED -
PLOT DATE = *DATE*	DATE -	REVISED -



**Allen Henderson & Associates, Inc.**  
 Civil and Structural Engineers Springfield, IL  
 62703 Phone: (217)544-8033 IL Design Firm  
 No. 184-001907

**TYPICAL ROADWAY SECTIONS**

SCALE: NONE SHEET NO. 3 OF 3 SHEETS STA. 632+50.00 TO STA. 633+50.00

F.A.P. RTE.	SECTION	COUNTY	TOTAL SHEETS	SHEET NO.
685	(115)B-2	HANCOCK	28	10
CONTRACT NO. 72F07				
FED. ROAD DIST. NO. ILLINOIS FED. AID PROJECT				

SECTION 18, T. 7 N., R. 6 W., 4TH P.M.

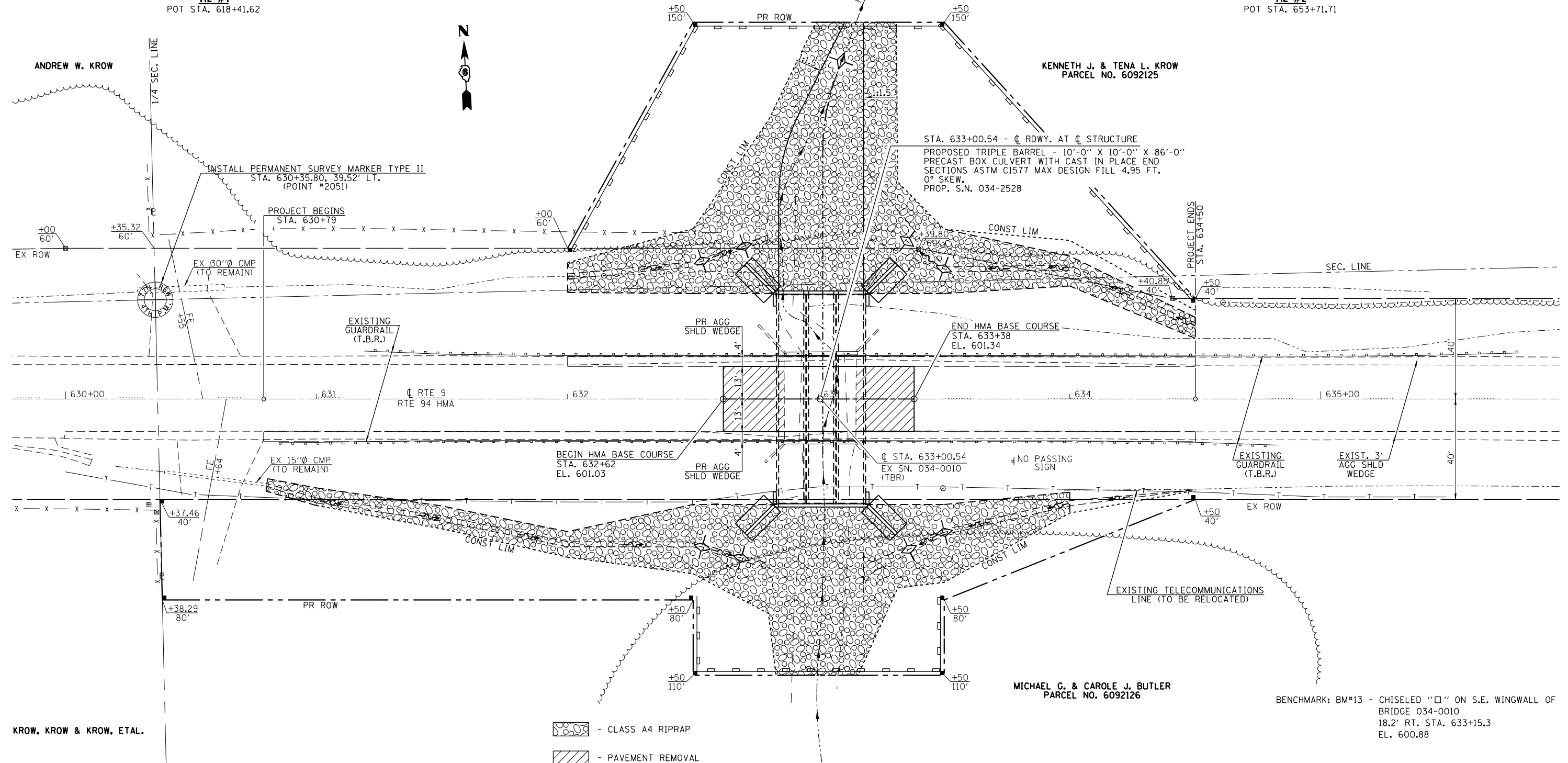
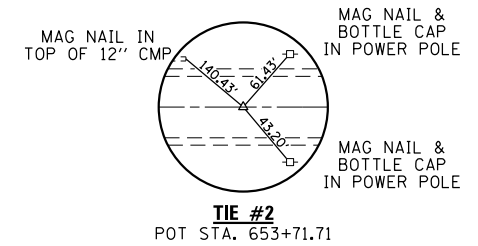
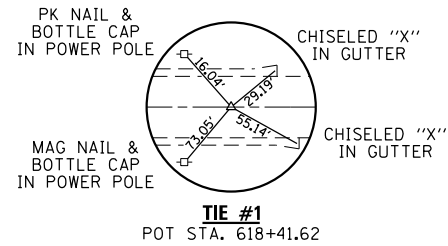

- CLASS A4 RIPRAP
- PAVEMENT REMOVAL

SECTION 19, T. 7 N., R. 6 W., 4TH P.M.

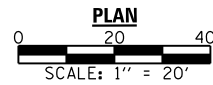

BRANCH OF CAMP CREEK 0.4 MI. OF IL. 94

POINT #	NORTHING	EASTING	STATION	OFFSET	DESCRIPTION	MONUMENT	TYPE	TIFF#
2051	1431482.002	2029412.072	630+35.8	-39.52	S 1/4 COR SEC 18, T-7-N, R-6-W, 4th PM HANCOCK CO.	5/8" REBAR	TYPE II	3571.TIF

KROW, KROW & KROW, ETAL.

FILE NAME =	USER NAME = *USER*	DESIGNED -	REVISED -	<p><b>Allen Henderson &amp; Associates, Inc.</b> Civil and Structural Engineers Springfield, IL 62703 Phone: (217)544-8033 IL Design Firm No. 184-001907</p>	<b>ROADWAY PLAN</b>	F.A.P. RTE. 685	SECTION (115)B-2	COUNTY HANCOCK	TOTAL SHEETS 28	SHEET NO. 11	
*FILEL#		DRAWN -	REVISED -		SCALE: 1" = 20'	SHEET NO. 1 OF 1 SHEETS	STATIONING: STA. 630+00 TO STA. 634+50		CONTRACT NO. 72F07		
		CHECKED -	REVISED -				FED. ROAD DIST. NO.		ILLINOIS FED. AID PROJECT		
		DATE -	REVISED -								

PLAN	SURVEYED	BY	DATE
	PLOTTED		
	NOTE BOOK NO.		
	CHECKED		
	ALIGNMENT		
	CADD FILE NAME		

PROFILE	SURVEYED	BY	DATE
	GRADES CHECKED		
	STRUCTURE		
	NOTATIONS CHKD		
	NO.		

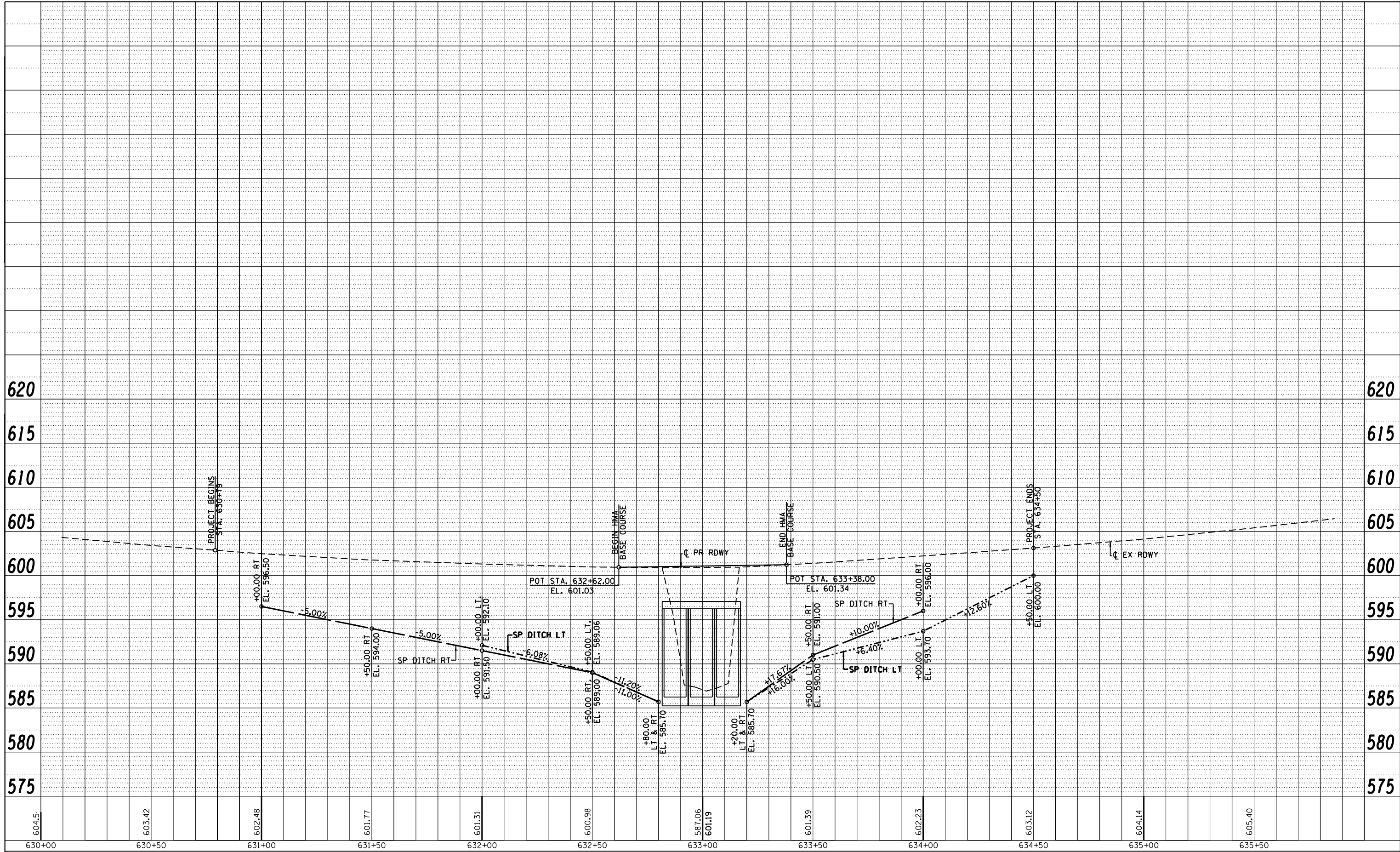

FILE NAME =  
\*FILEL\*

USER NAME = \*USER\*  
PLOT SCALE = \*SCALE\*  
PLOT DATE = \*DATE\*

DESIGNED -  
CHECKED -  
DRAWN -  
CHECKED -

REVISED -  
REVISED -  
REVISED -  
REVISED -



**Allen Henderson & Associates, Inc.**  
Civil and Structural Engineers Springfield, IL  
62703 Phone: (217)544-8033 IL Design Firm  
No. 184-001907

**ROADWAY PROFILE**  
SCALE: 1" = 20'  
SHEET NO. 1 OF 1 SHEETS  
STA. 630+00 TO STA. 634+50

F.A.P. RTE.	SECTION	COUNTY	TOTAL SHEETS	SHEET NO.
685	(115)B-2	HANCOCK	28	12
CONTRACT NO. 72F07				
FED. ROAD DIST. NO. ILLINOIS FED. AID PROJECT				

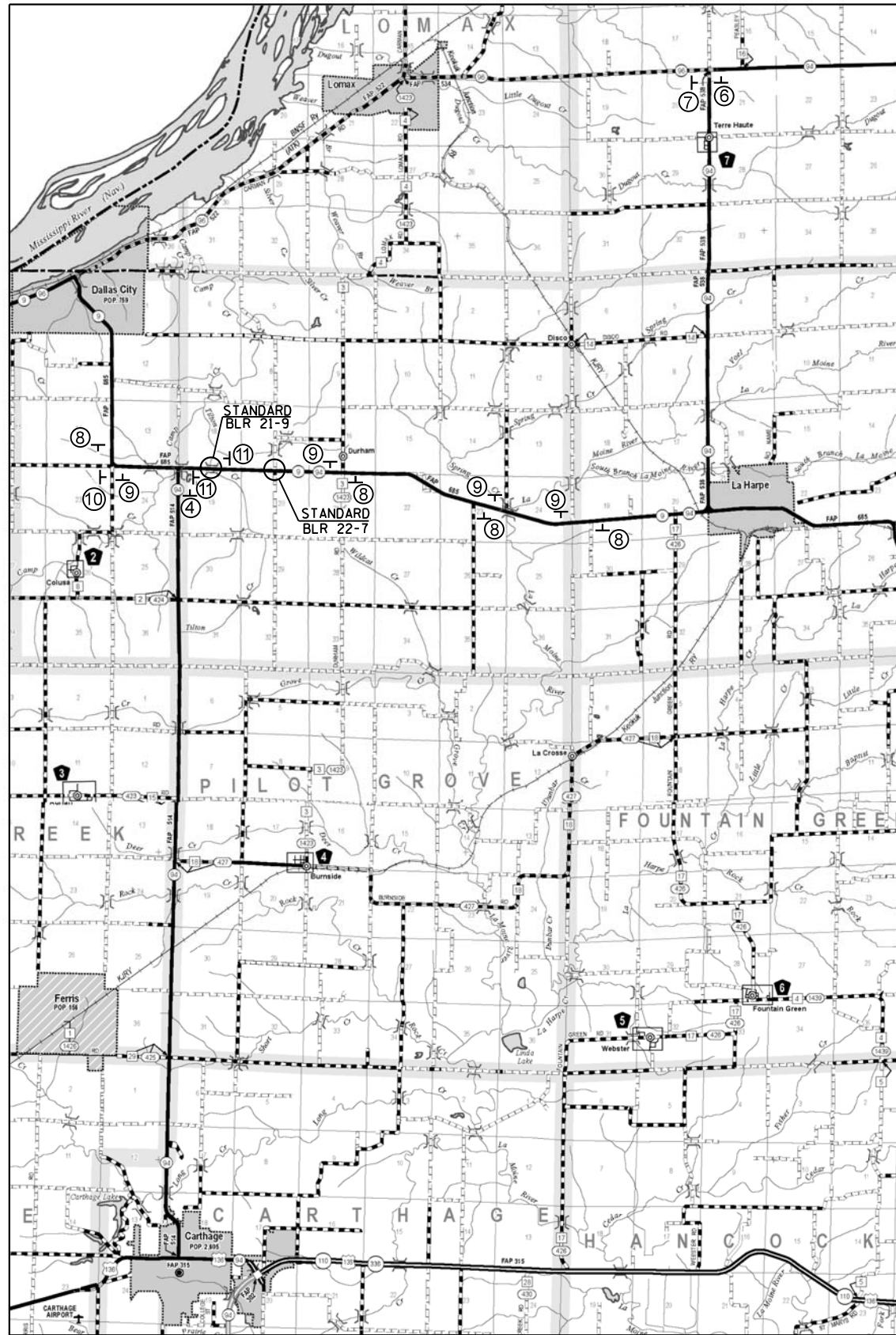

DETOUR MAP

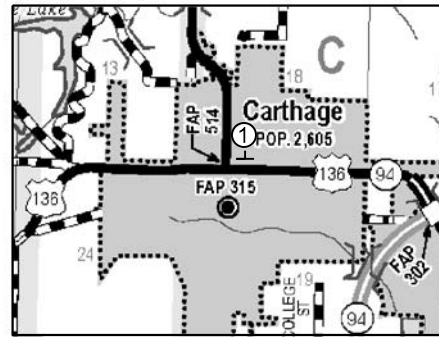

CARTHAGE

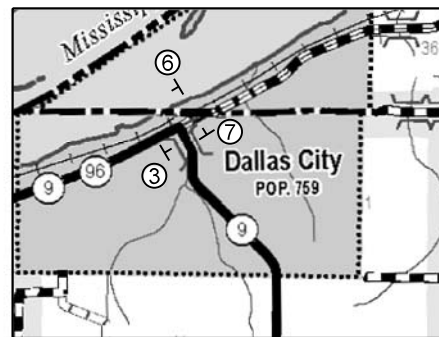

DALLAS CITY

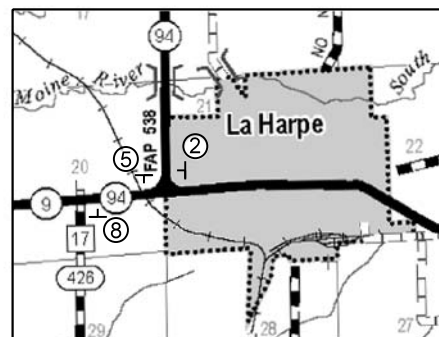

LA HARPE

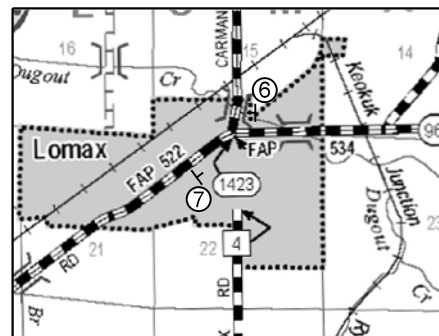

LOMAX

SIGN	MILES AHEAD	WITH
1	13	
2	8	M4-10R
3	5	M4-8 & M6-3
4	1	M4-10L
5	8	M4-10R

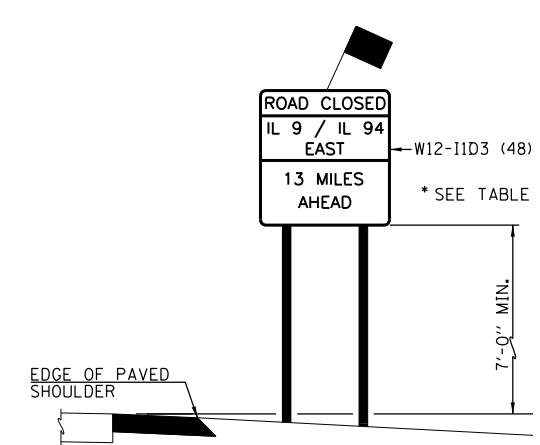

SIGN 1

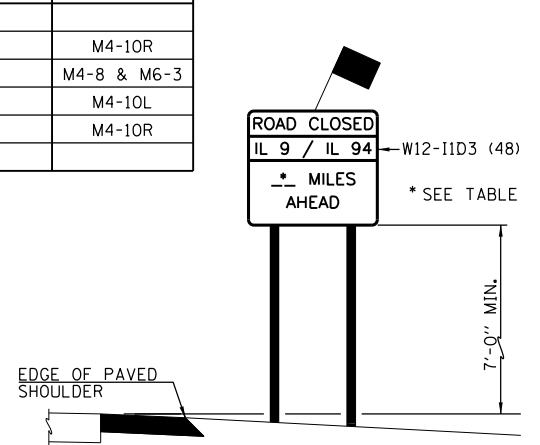

SIGNS 2, 3, 4 & 5

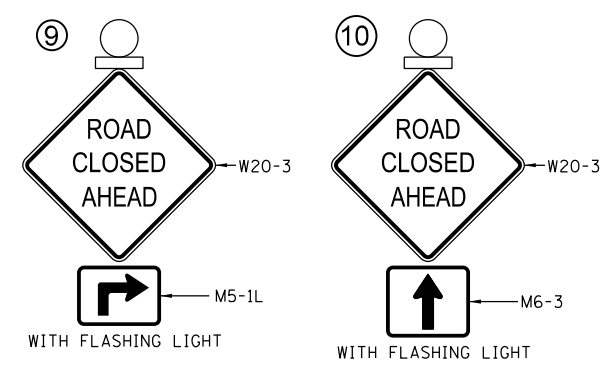
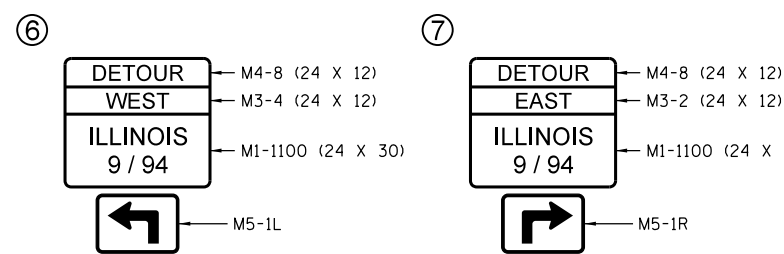
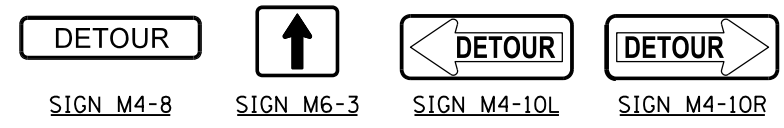

**PRE-ROAD CLOSURE WORK**

- 1.) THE CONTRACTOR SHALL REMOVE ALL TREES PER TREE REMOVAL SCHEDULE.

**SUGGESTED CONSTRUCTION SEQUENCE**

**WORK DONE UNDER ROAD CLOSURE**

- 1.) THE CONTRACTOR SHALL PLACE PORTABLE CHANGEABLE MESSAGE SIGN BOARDS TWO WEEKS BEFORE CONSTRUCTION BEGINS.
- 2.) THE CONTRACTOR SHALL PLACE ROAD CLOSED SIGNS IN ACCORDANCE WITH THIS SHEET AND STANDARD BLR 21-9.
- 3.) REMOVE EXISTING PAVEMENT AND AGGREGATE SHOULDERS FROM STA. 632+62 TO STA. 633+38.
- 4.) REMOVE EXISTING STRUCTURE STA. 633+00.54, AND EXISTING GUARDRAIL.
- 5.) INSTALL TRIPLE BARREL PRECAST CONCRETE BOX CULVERT AND GRANULAR CULVERT BACKFILL STA. 633+00.54.
- 6.) INSTALL HMA BASE COURSE, 9/2" AND HMA SURFACE COURSE, STA. 632+62 TO STA. 633+38.
- 7.) THE CONTRACTOR SHALL OPEN THE ROAD TO TRAFFIC AND COMPLETE REMAINING WORK UNDER FLAGGERS.

**WORK DONE UNDER FLAGGERS**

- 1.) CONSTRUCT CAST IN PLACE CONCRETE END SECTIONS AND PERMANENT STEEL SHEET PILING WINGWALLS WITH CAPS @ STA. 633+00.54 LT. & RT.
- 2.) SHAPE AND GRADE EARTH FOR SHOULDERS AND DITCHES STA. 630+79 TO STA. 634+50.
- 3.) CONSTRUCT AGGREGATE WEDGE SHOULDERS STA. 630+79 TO STA. 634+50 RT. AND STA. 632+00 TO STA. 634+50 LT.
- 4.) FINAL STRIPING, SEEDING AND MISCELLANEOUS CLEANUP.

FILE NAME =	USER NAME =	DESIGNED - RKA	REVISED -
*FILES*		DRAWN - RKA	REVISED -
	PLOT SCALE =	CHECKED - CPK	REVISED -
	PLOT DATE = \$DATE*	DATE - 3/25/08	REVISED -

**Allen Henderson & Associates, Inc.**  
 Civil and Structural Engineers Springfield, IL.  
 62703 Phone: (217)544-8033 IL Design Firm  
 No. 184-001907

<b>CONSTRUCTION SEQUENCE &amp; ROAD CLOSED SIGNING</b>		
SCALE: NONE	SHEET NO. 1 OF 1 SHEETS	STA. 630+00 TO STA. 634+50

F.A.P. RTE.	SECTION	COUNTY	TOTAL SHEETS	SHEET NO.
685	(115)B-2	HANCOCK	28	13
CONTRACT NO. 72F07				
FED. ROAD DIST. NO. ILLINOIS FED. AID PROJECT				

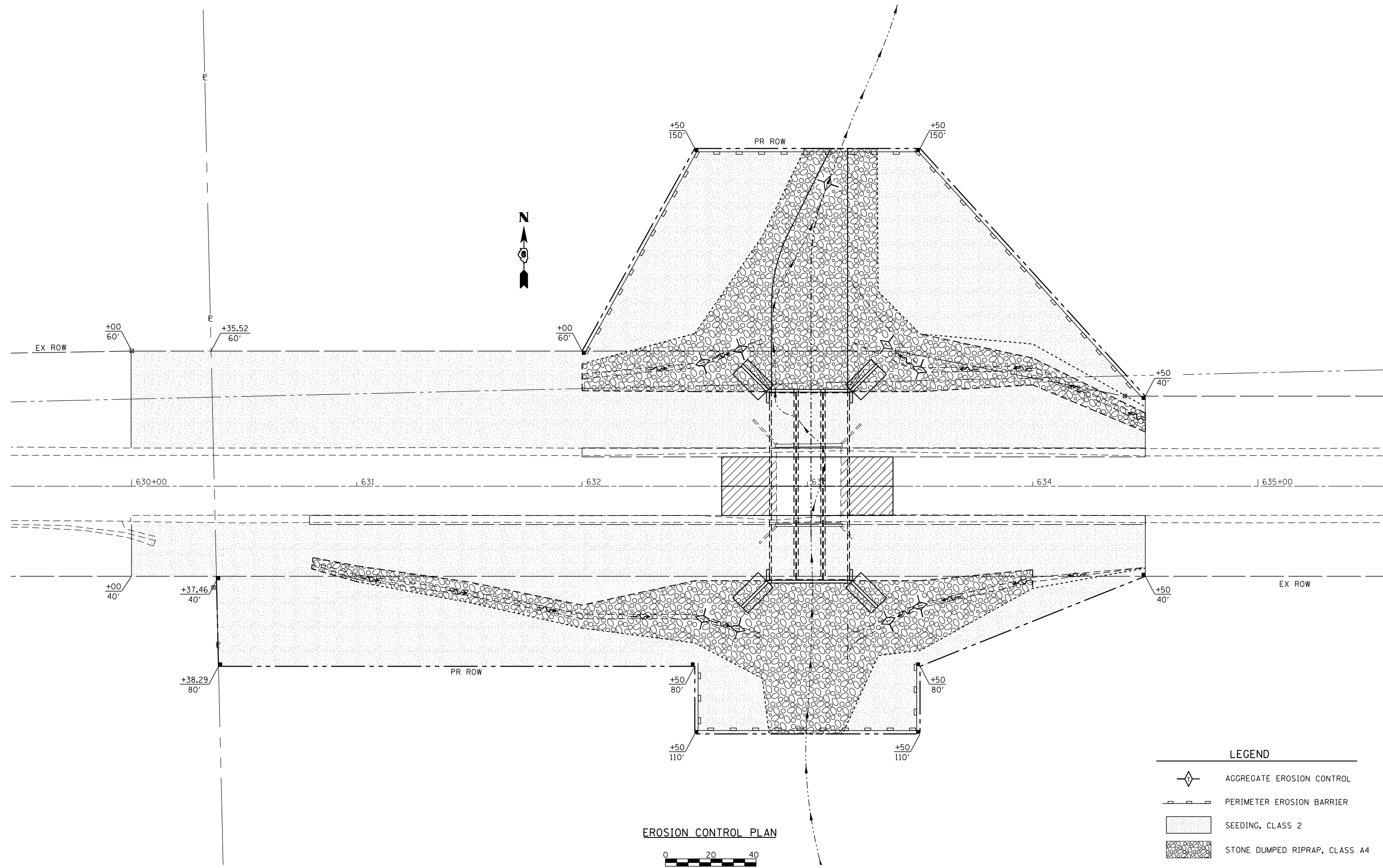

EROSION CONTROL PLAN

LEGEND				
	AGGREGATE EROSION CONTROL			
	PERIMETER EROSION BARRIER			
	SEEDING, CLASS 2			
	STONE DUMPED RIPRAP, CLASS A4			

FILE NAME =  
\*FILEL\*

USER NAME = \*USER\*  
PLOT SCALE = \*SCALE\*  
PLOT DATE = \*DATE\*

DESIGNED -  
DRAWN -  
CHECKED -  
DATE -

REVISED -  
REVISED -  
REVISED -  
REVISED -



**Allen Henderson & Associates, Inc.**  
Civil and Structural Engineers Springfield, IL.  
62703 Phone: (217)544-8033 IL Design Firm  
No. 184-001907

**EROSION CONTROL PLAN**  
SCALE: 1" = 20' SHEET NO. 1 OF 1 SHEETS STA. 630+00 TO STA. 634+50

F.A.P. RTE.	SECTION	COUNTY	TOTAL SHEETS	SHEET NO.
685	(115)B-2	HANCOCK	28	14
CONTRACT NO. 72F07				
FED. ROAD DIST. NO. ILLINOIS FED. AID PROJECT				

Benchmark: BM#13 - Chiseled "□" on S.E. Wingwall of Exist. Bridge 034-0010  
18.2' Rt. Sta. 633+15.3 El. 600.88

Existing Structure: 034-0010 built in 1928 under Section 115-B. The existing structure is a single span reinforced concrete slab bridge supported on pile supported closed abutments. Back to Back of abutment length is 30'-0". Out to Out of deck width is 36'-2". The existing structure is to be removed and replaced with a triple 10'x10' precast concrete box culvert. Traffic to be detoured during construction.

No Salvage.

**INDEX OF SHEETS**

- 1.) General Plan
- 2.-3.) Culvert Details
- 4.) Bar Splicer Assembly
- 5.-6.) Borings

**TOTAL BILL OF MATERIAL**

ITEM	UNIT	TOTAL
Removal of Existing Structures	Each	1
Name Plates	Each	1
Box Culvert End Sections, Culvert No. 1	Each	2
Precast Concrete Box Culverts 10'x10'	Foot	249
Rockfill-Foundation	Ton	493

**WATERWAY INFORMATION**

Flood	Freq. Yr.	Q C.F.S.	Opening Sq. Ft.		Head - Ft.		Headwater El.	
			Exist.	Prop.	Exist.	Prop.	Exist.	Prop.
Design			190	250	0.3	0	595.4	595.0
Base			2370	300	1.3	0.7	598.3	597.7
Overtopping (Exist.) > 500 Yr.								
Overtopping (Prop.) > 500 Yr.								
Max. Calc.			500	3230	2.0	1.8	599.8	599.7

10-Year Outlet Velocity from Existing Structure = 8.8 fps  
10-Year Outlet Velocity from Proposed Structure = 5.4 fps

**DESIGN SCOUR ELEVATION TABLE**

Design Scour Elevation (ft.)	D.S. Invert	U.S. Invert
	581.55	581.75

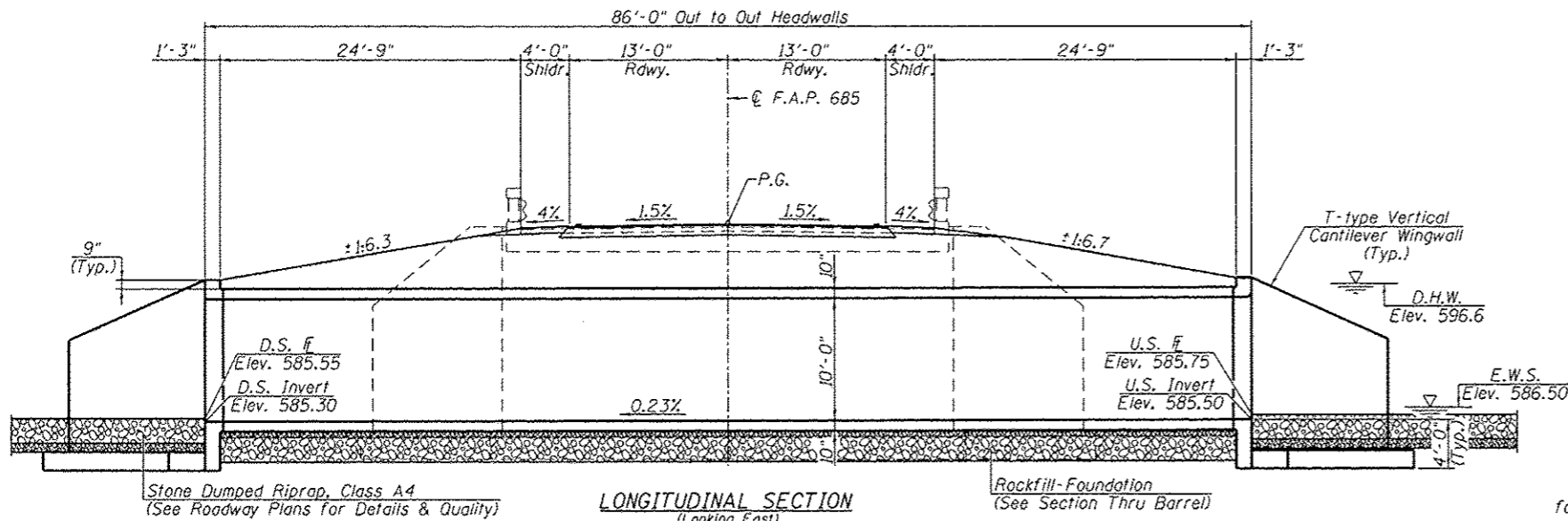

See Roadway Plans for limits and quantity of Granular Culvert Backfill.

Estimated limits of removal and replacement of unsuitable material. Final limits to be determined by the District Geotechnical Engineer in the field.

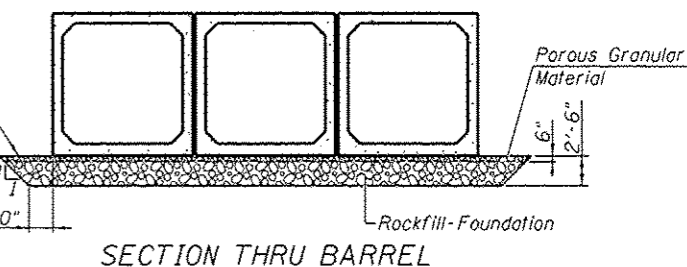

**GENERAL NOTES**

Contact the District Geotechnical Engineer to verify foundation conditions meet plan requirements.  
Layout of slope protection system may be varied to suit ground conditions as directed by the Engineer.  
Precast End Sections will not be allowed.  
Outside end of precast sections at the ends of the culvert shall not have a bell or spigot.  
Reinforcement bars designated (E) shall be epoxy coated. The Contractor shall excavate behind existing abutments prior to removal of existing superstructure to balance front and back soil pressure.  
The existing foundations should be removed entirely where it lies within the footprint of the proposed structure.  
All construction joints shall be bonded according to 503.09 of the Standard Specifications.  
The welded wire fabric extending from the precast boxes into the end sections shall have a minimum area of 0.20 in<sup>2</sup>/ft.  
Substitution of reinforcement bars for welded wire fabric is not allowed.

**LOADING HL 93**  
Allow 50#/sq. ft. for future wearing surface.

**DESIGN SPECIFICATIONS**

2012 AASHTO LRFD Bridge Design Specifications, 6th Edition with 2013 Interim Revisions.  
ASTM C 1577

**DESIGN STRESSES**

**FIELD UNITS**

f'c = 3,500 psi  
fy = 60,000 psi (Reinforcement)

**PRECAST UNITS**

f'c = 5,000 psi  
fy = 60,000 psi (Reinforcement)  
fy = 65,000 psi (Welded Wire Fabric)

**DESIGN FILL HEIGHT**

Design earth cover = 4.95'

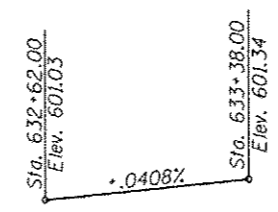
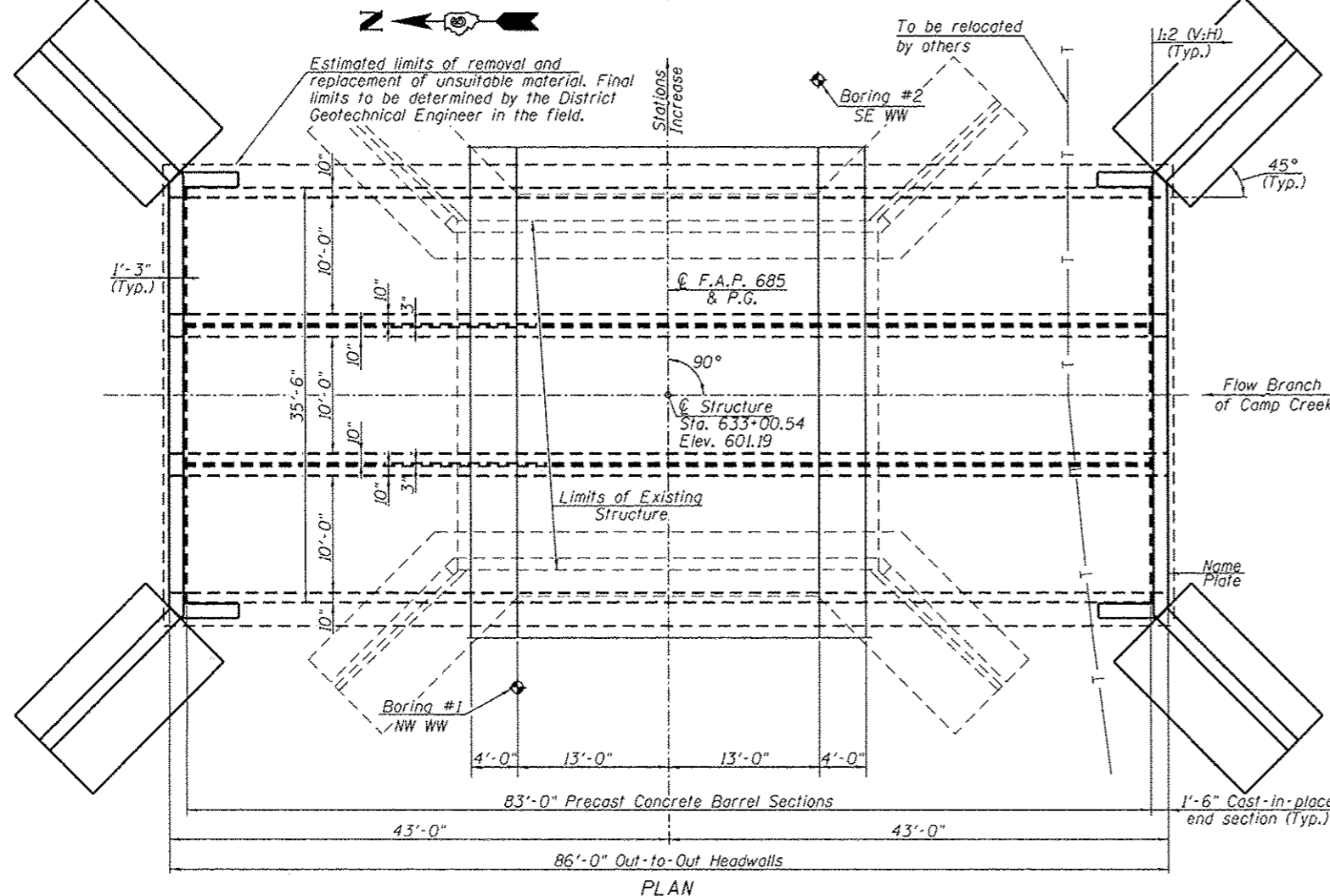

**PROFILE GRADE**  
(Along F.A.P. 685)

STATION 633+00.54  
BUILT 20 BY  
STATE OF ILLINOIS  
F.A.P. RT. 685 SEC. (115)B-2  
LOADING HL93  
STR. NO. 034-2528

**NAME PLATE**  
See Sta. 515001

7/29/2014  
GERALD B. ROTHERHAM  
081-005673  
LICENSED  
STRUCTURAL  
ENGINEER  
STATE OF ILLINOIS  
EXPIRATION: 11/30/2014

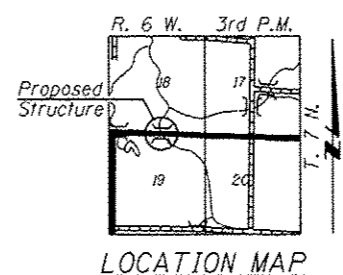

**GENERAL PLAN**  
IL RTE. 9/IL RTE. 94 OVER  
BRANCH OF CAMP CREEK / TILTON CREEK  
F.A.P. RTE. 685 - SEC. (115)B-1  
HANCOCK COUNTY  
STATION 633+00.54  
STRUCTURE NO. 034-2528

**ONE END SECTION  
BILL OF MATERIAL**  
(For information only)

Bar	No.	Size	Length	Shape
h	6	#6	36'-0"	—
h <sub>1</sub>	6	#6	36'-9"	—
h <sub>2</sub>	34	#4	1'-7"	⌒
h <sub>3</sub>	34	#4	2'-0"	⌒
h <sub>4</sub>	22	#4	4'-2"	⌒
h <sub>5</sub>	8	#6	4'-9"	—
h <sub>6</sub>	8	#6	6'-6"	⌒
h <sub>7</sub>	56	#4	15'-8"	—
n(E)	44	#7	7'-8"	⌒
s	45	#4	7'-11"	⌒
s <sub>1</sub>	35	#4	4'-4"	⌒
s <sub>2</sub>	35	#4	4'-5"	⌒
i	98	#6	9'-3"	—
v	24	#5	3'-9"	⌒
v <sub>1</sub>	16	#5	11'-4"	—
v <sub>2</sub>	44	#7	13'-4"	—
v <sub>3</sub>	34	#4	13'-4"	—
w	40	#5	15'-9"	—
Concrete Box Culverts			Cu. Yd.	51.7
Reinforcement Bars			Pound	5770
Reinforcement Bars, Epoxy Coated			Pound	690
Bar Splicers			Each	10
Geocomposite Wall Drain			Sq. Yd.	31
Porous Granular Backfill			Cu. Yd.	42

\*s<sub>1</sub> bar is to be placed on the upstream end only.  
\*s<sub>2</sub> bar is to be placed on the downstream end only.  
The above pay items will not be measured for payment but shall be included in the contract unit price for Box Culvert End Sections of the culvert number specified.

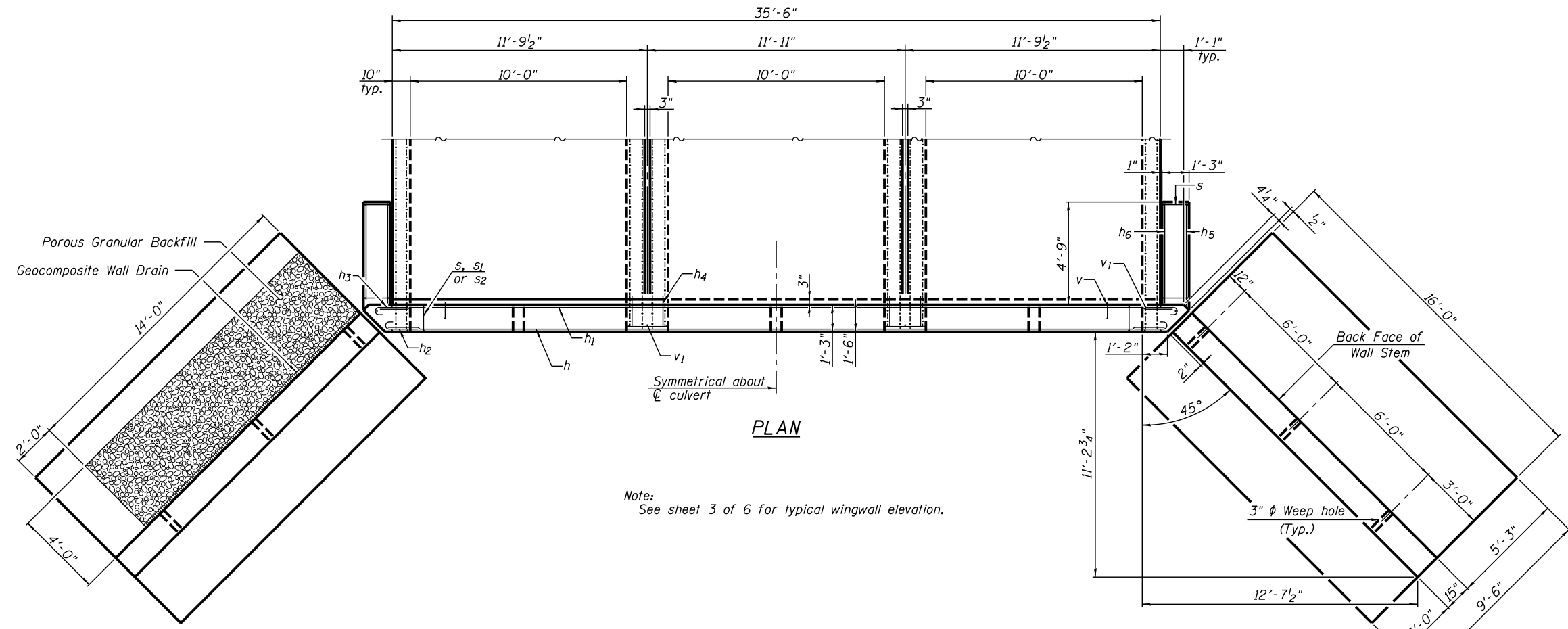

Note:  
See sheet 3 of 6 for typical wingwall elevation.

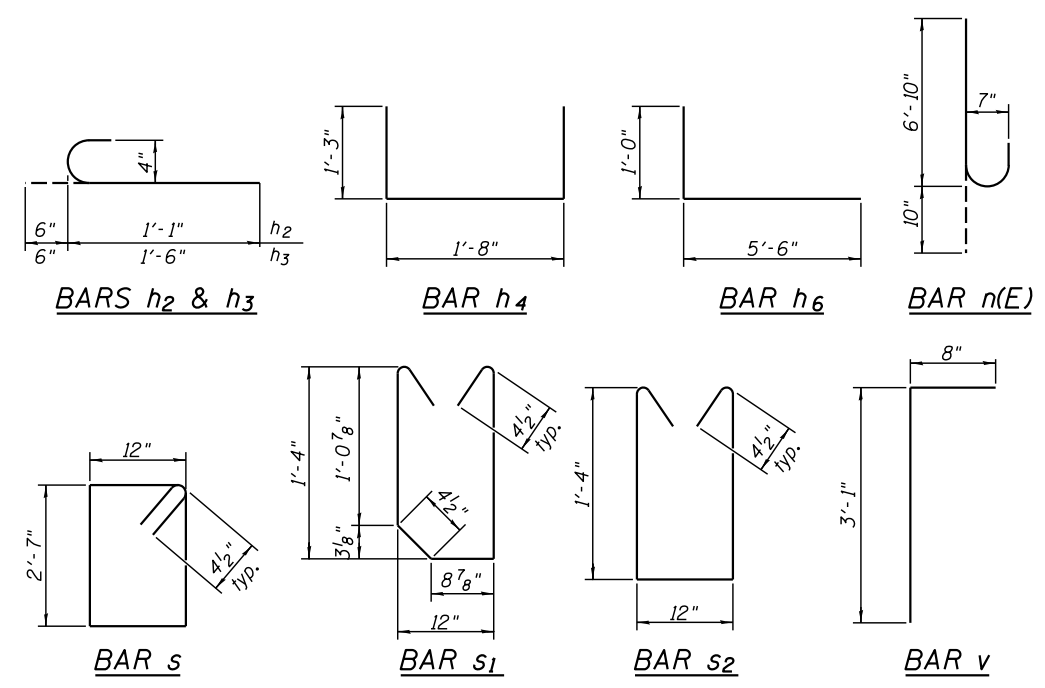
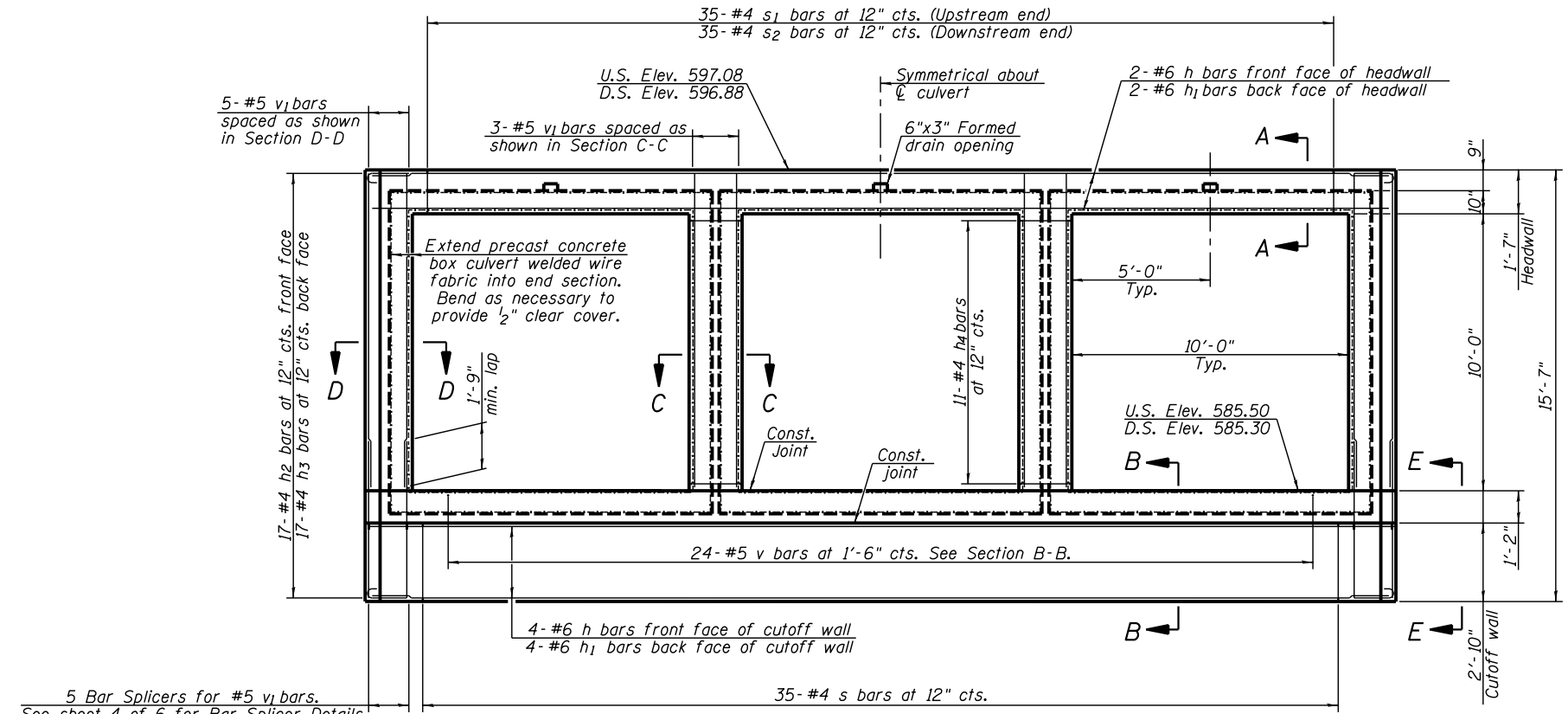

5 Bar Splicers for #5 v<sub>1</sub> bars.  
See sheet 4 of 6 for Bar Splicer Details

Wingwall omitted in this view for clarity.  
See sheet 3 of 6 for additional wingwall details.



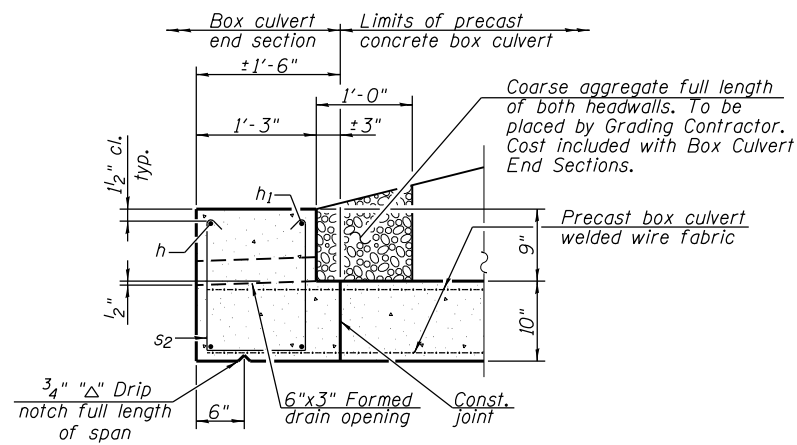

**SECTION A-A**  
(Downstream End)

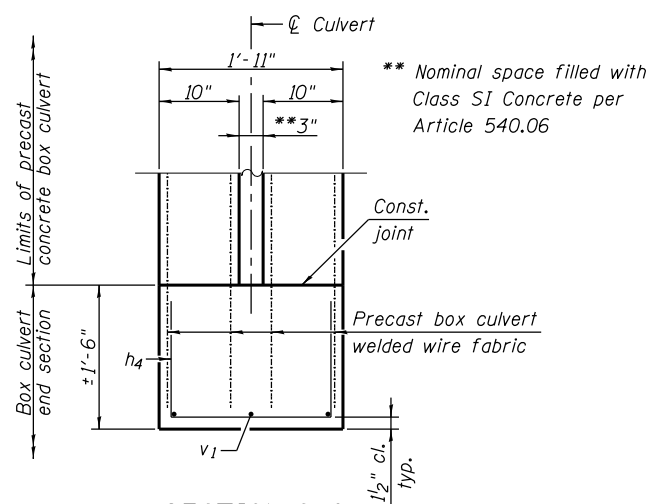

**SECTION C-C**

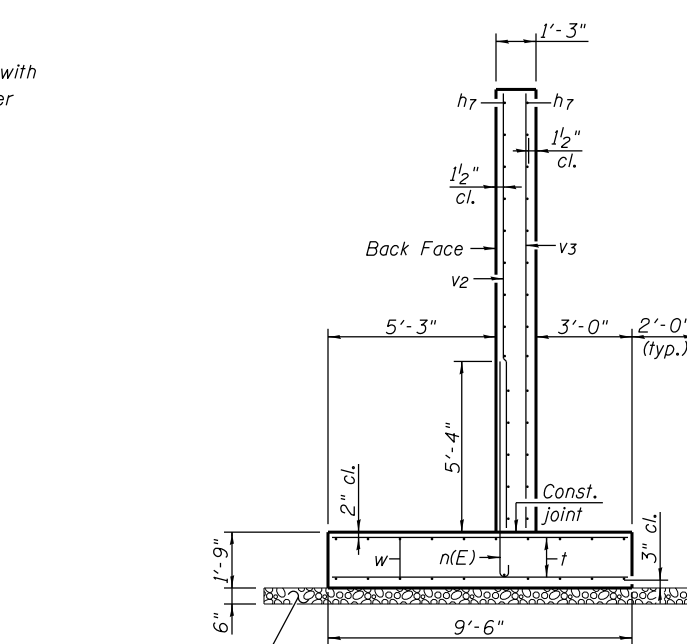

**WINGWALL CROSS SECTION**

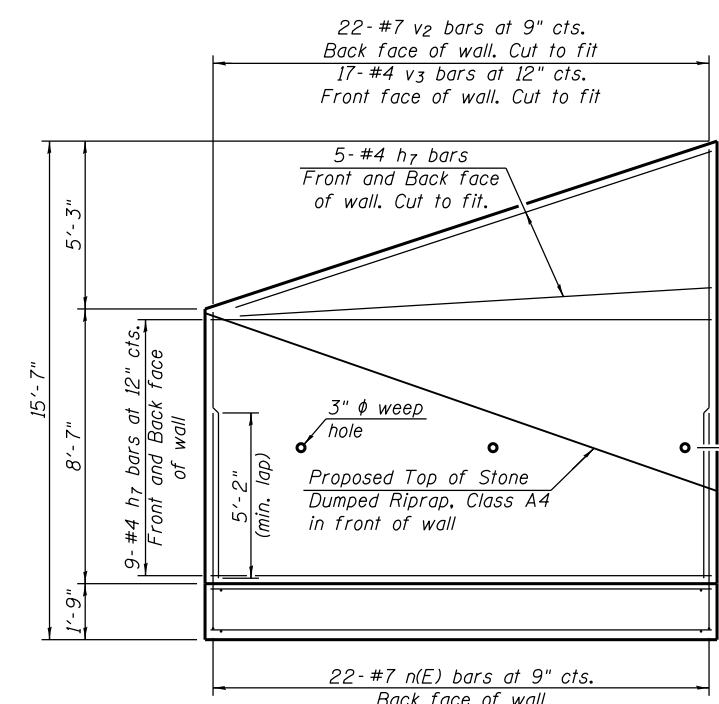

**WINGWALL ELEVATION**

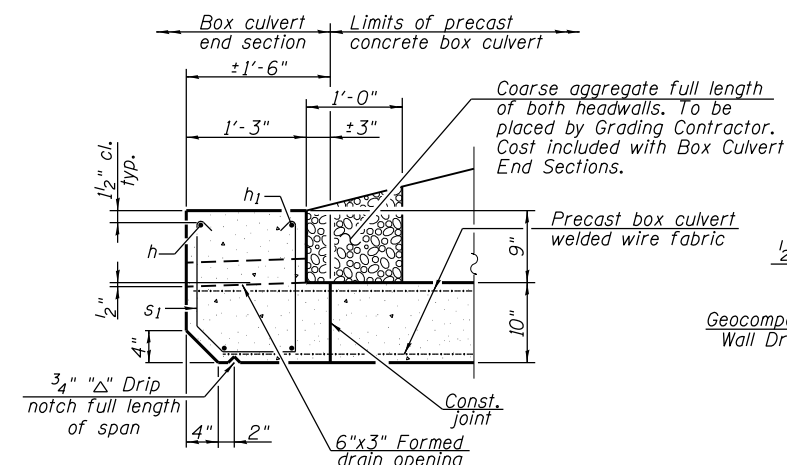

**SECTION A-A**  
(Upstream End)

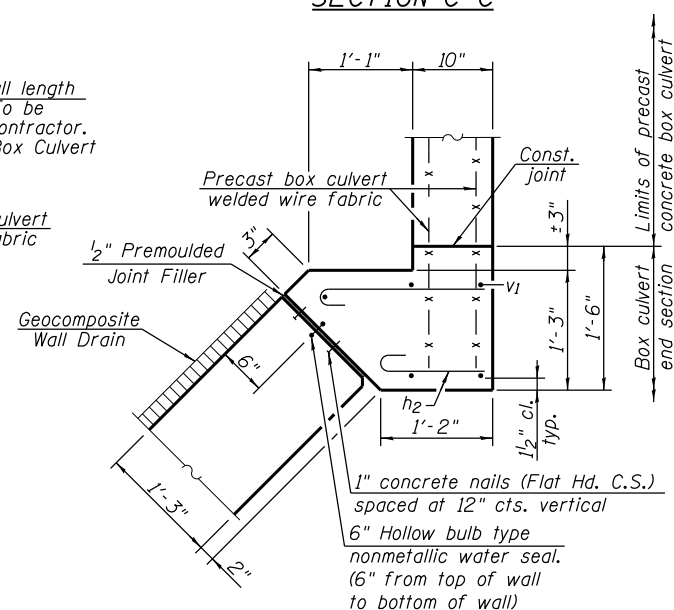

**SECTION D-D**

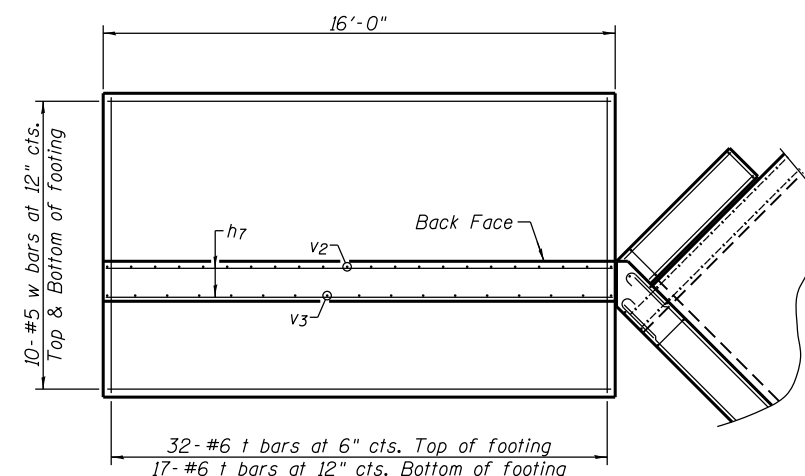

**WINGWALL PLAN**

Maximum Service Bearing Pressure = 2.4 ksf

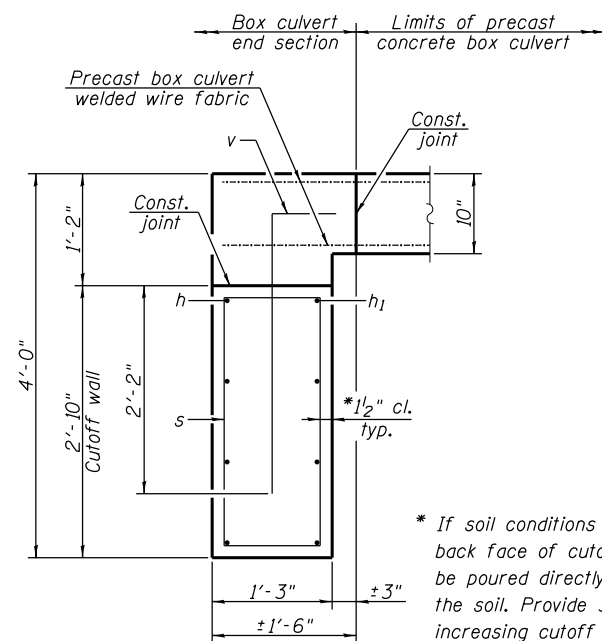

**SECTION B-B**

\* If soil conditions permit, the back face of cutoff wall may be poured directly against the soil. Provide 3" cover by increasing cutoff wall thickness to 1'-4 1/2".

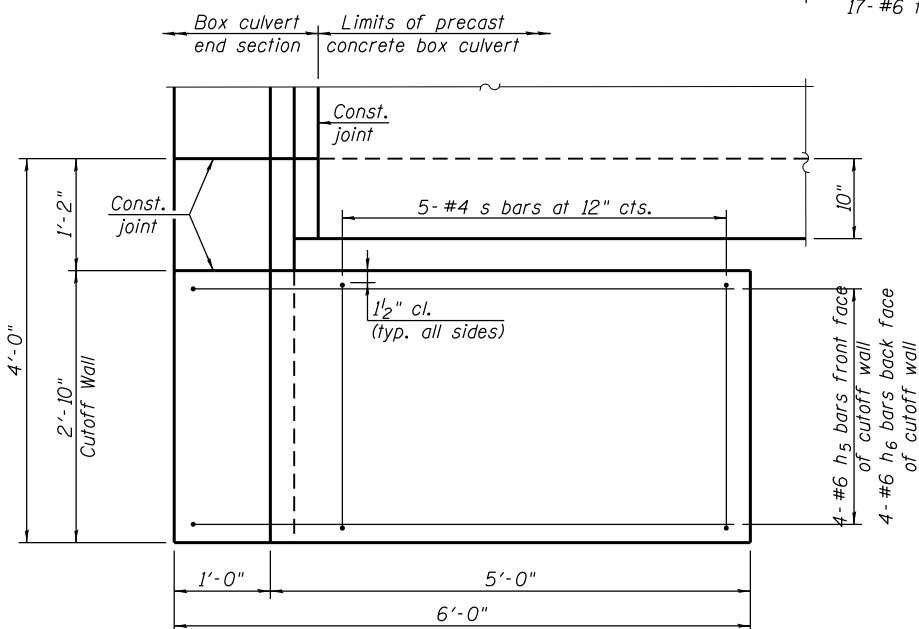

**SECTION E-E**

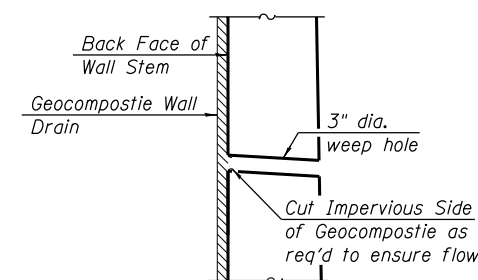

**WEEP HOLE DRAIN DETAIL**

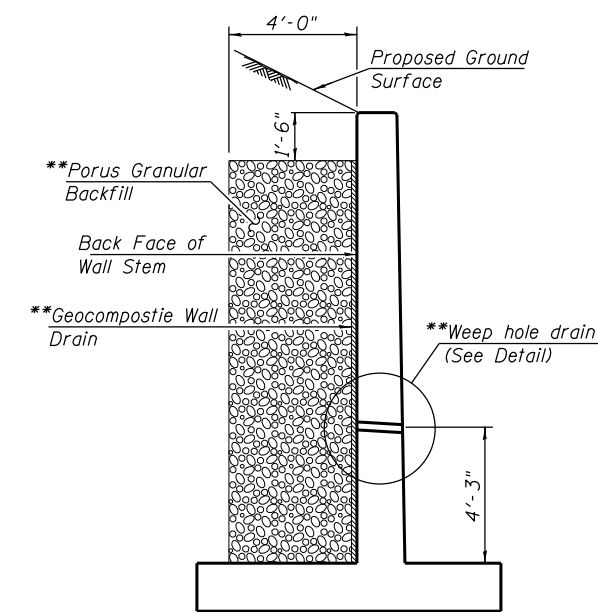

**DRAINAGE DETAIL**

FILE NAME =	USER NAME =	DESIGNED -	REVISED -	 <b>Allen Henderson &amp; Associates, Inc.</b> Civil and Structural Engineers Springfield, IL. 62703 Phone: (217)544-8033 IL Design Firm No. 184-001907	<b>CULVERT DETAILS</b> <b>STRUCTURE NO. 034-2528</b>	F.A.P. RTE.	SECTION	COUNTY	TOTAL SHEETS	SHEET NO.
PLOT SCALE =	DRAWN -	REVISED -	685			(115)B-2	HANCOCK	28	17	
PLOT DATE	CHECKED -	REVISED -	CONTRACT NO. 72F07							
ILLINOIS FED. AID PROJECT										

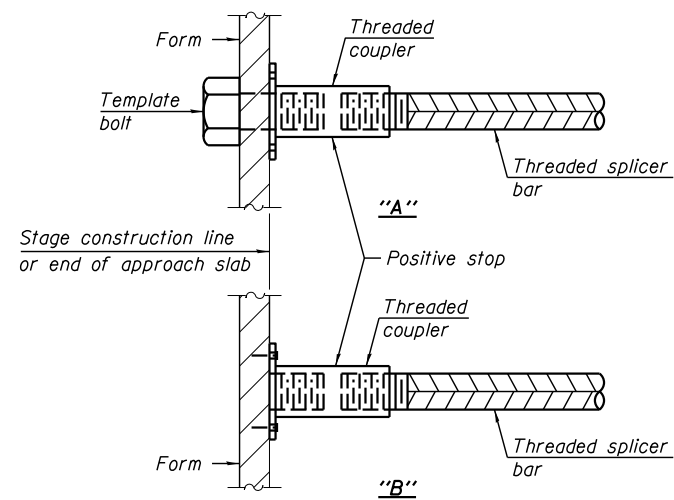

**INSTALLATION AND SETTING METHODS**

"A" : Set bar splicer assembly by means of a template bolt.  
 "B" : Set bar splicer assembly by nailing to wood forms or cementing to steel forms.

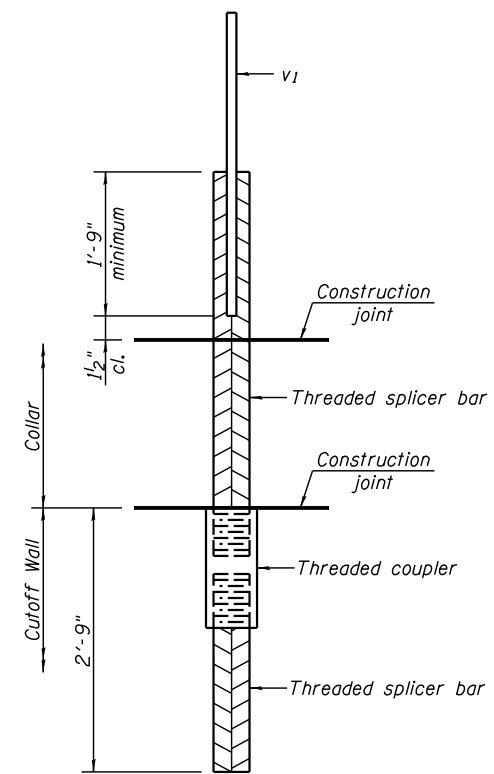

**FOR BOX CULVERT END SECTIONS**

**NOTES**

Splicer bars shall be deformed with threaded ends and have a minimum 60 ksi yield strength.  
 All reinforcement shall be lapped and tied to the splicer bars.  
 See approved list of bar splicer assemblies and mechanical splicers for alternatives.

FILE NAME =	USER NAME =	DESIGNED -	REVISD -	 <b>Allen Henderson &amp; Associates, Inc.</b> Civil and Structural Engineers Springfield, IL. 62703 Phone: (217)544-8033 IL Design Firm No. 184-001907	<b>BAR SPLICER ASSEMBLY AND MECHANICAL SPLICER DETAILS</b> <b>STRUCTURE NO. 034-2528</b> SHEET NO. 4 OF 6 SHEETS	F.A.P. RTE.	SECTION	COUNTY	TOTAL SHEETS	SHEET NO.	
		CHECKED -	REVISD -			685	(115)B-2	HANCOCK	28	18	
PLOT SCALE =	DRAWN -	REVISD -	REVISD -			<b>CONTRACT NO. 72F07</b>					
PLOT DATE =	CHECKED -	REVISD -	REVISD -			ILLINOIS FED. AID PROJECT					





# SOIL BORING LOG

Page 1 of 2  
Date 4/11/13

ROUTE IL 9/94 DESCRIPTION IL 9/94 over Branch of Camp Cr. LOGGED BY M. Tappan

SECTION (115) B-1 LOCATION SW 1/4, SEC. 18, TWP. 7N, RNG. 6W, 4 PM

COUNTY Hancock DRILLING METHOD HSA HAMMER TYPE 140 # Auto

STRUCT. NO. PR\_034-2528  
Station 633+00  
BORING NO. 2 SE WW  
Station 633+27  
Offset 13.0ft RT  
Ground Surface Elev. 602.0 ft

DEPTH (ft)	DIAMETER (ft)	SOIL TYPE	MOISTURE (%)	UNCONFINED COMPRESSIVE STRENGTH (tsf)	DEPTH (ft)	DIAMETER (ft)	SOIL TYPE	MOISTURE (%)	UNCONFINED COMPRESSIVE STRENGTH (tsf)
0		Brown and Dark Gray Moist SILTY CLAY LOAM (Fill)			0		Light Brown and Gray Moist SILTY CLAY (Till) (continued)		
2	.90		20		3	1.8			16
3	B				5	B			
1		Brown and Gray			1		Gray Moist SILTY CLAY (Till)		
1	.60		25		3	1.7			18
2	S-12				4	B			
596.00		Brown and Gray Very Moist SILTY CLAY LOAM			0				
1	.50		30		2	2.4			17
2	S-12				4	B			
574.00		Brownish Gray Moist CLAY LOAM (Till)			1				
0	.50		25		4	4.3			15
2	S-13				8	B			
591.50		Light Brown and Gray Moist SILTY CLAY (Till)			1				
0	1.4		23		3	3.1			17
2	B				5	B			
0	.90		24		1		Olive Brown and Gray Moist CLAY LOAM (Till)		
1	B				3	3.1			17
2	B				5	B			
563.50		Gray Moist SILTY CLAY (Till) With Some Woody Organics			1		Light Blue Gray Shaley CLAY Residuum With Broken Limestone Clasts.		
1	1.5		17		5	3.7			22
2	B				8	P			

The Unconfined Compressive Strength (UCS) Failure Mode is indicated by (B-Bulge, S-Shear, P-Penetrometer, E-Estimated) Abbreviations W.O.H - Sampler Advanced By Weight of Hammer, W.O.P - Advanced by Weight of Pipe, B.S. - Before Seating The SPT (N value) is the sum of the last two blow values in each sampling zone (AASHTO T206) BBS, from 137 (Rev. 8-99)

File Name: S:\SOILS\GINT FILES\034 HANCOCK\034-2528 IL9-94 OVER BRANCH CAMP CREEK.GPJ Data Template D0TEMP.LT.GDT Date Printed 3/19/14



# SOIL BORING LOG

Page 2 of 2  
Date 4/11/13

ROUTE IL 9/94 DESCRIPTION IL 9/94 over Branch of Camp Cr. LOGGED BY M. Tappan

SECTION (115) B-1 LOCATION SW 1/4, SEC. 18, TWP. 7N, RNG. 6W, 4 PM

COUNTY Hancock DRILLING METHOD HSA HAMMER TYPE 140 # Auto

STRUCT. NO. PR\_034-2528  
Station 633+00  
BORING NO. 2 SE WW  
Station 633+27  
Offset 13.0ft RT  
Ground Surface Elev. 602.0 ft

DEPTH (ft)	DIAMETER (ft)	SOIL TYPE	MOISTURE (%)	UNCONFINED COMPRESSIVE STRENGTH (tsf)
561.00		Gray Well Indurated Crystalline LIMESTONE. Interbedded With Gray Calcareous SHALE		
40				16
21				
559.50		Auger Refusal at 42.5 Feet Boring Completed		
2				
-45				
-50				
-55				
-60				

The Unconfined Compressive Strength (UCS) Failure Mode is indicated by (B-Bulge, S-Shear, P-Penetrometer, E-Estimated) Abbreviations W.O.H - Sampler Advanced By Weight of Hammer, W.O.P - Advanced by Weight of Pipe, B.S. - Before Seating The SPT (N value) is the sum of the last two blow values in each sampling zone (AASHTO T206) BBS, from 137 (Rev. 8-99)

File Name: S:\SOILS\GINT FILES\034 HANCOCK\034-2528 IL9-94 OVER BRANCH CAMP CREEK.GPJ Data Template D0TEMP.LT.GDT Date Printed 3/19/14

DATE	
BY	
FINAL SURVEY	SURVEYED
NOTE BOOK	PLOTTED
NO.	TEMPLATE
	AREAS CHECKED
	AREAS CHECKED

DATE	
BY	
ORIGINAL SURVEY	SURVEYED
NOTE BOOK	PLOTTED
NO.	TEMPLATE
	AREAS CHECKED
	AREAS CHECKED

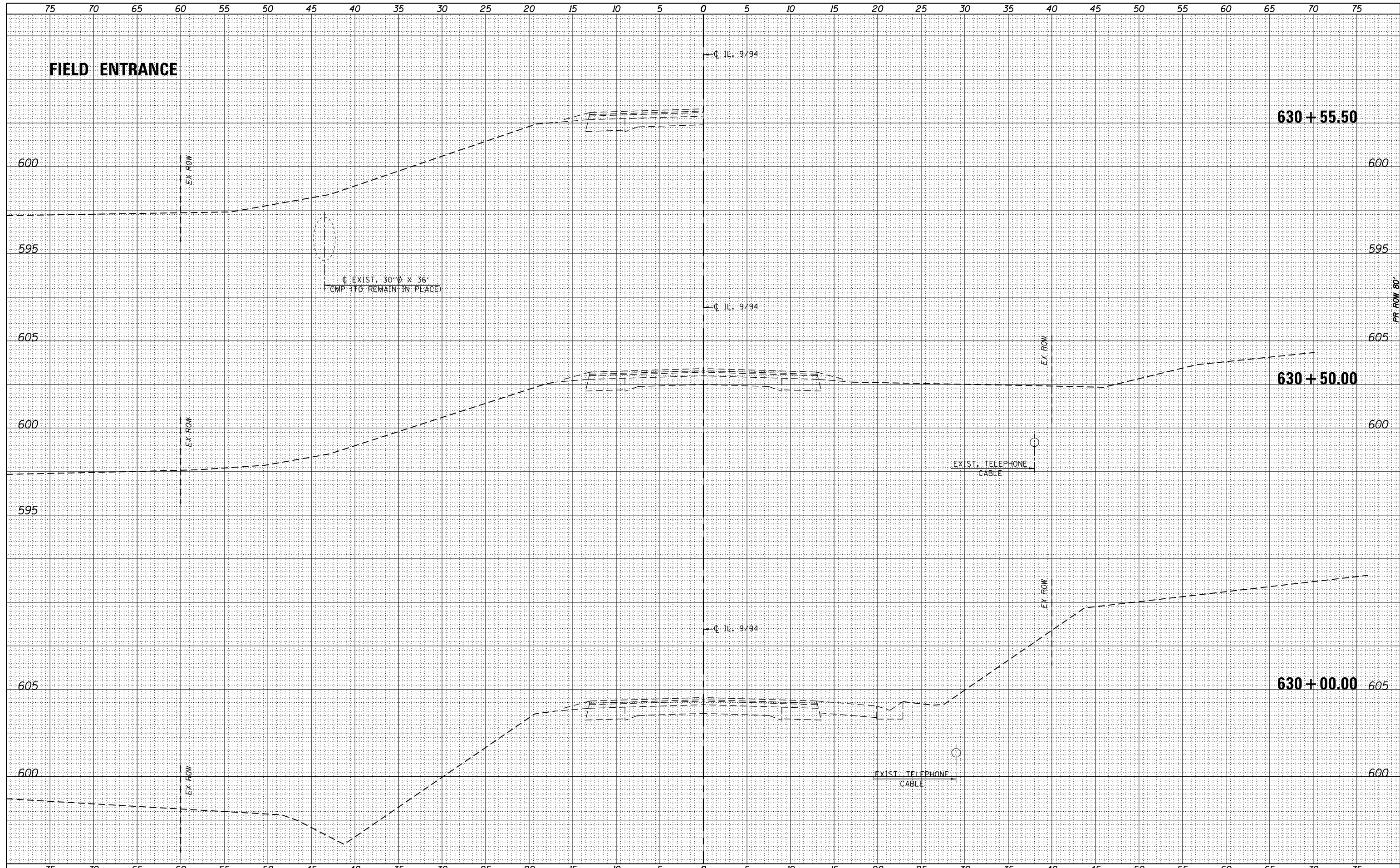

FILE NAME =  
 \*FILEL\*

USER NAME = *USER*	DESIGNED -	REVISED -
	DRAWN -	REVISED -
PLOT SCALE = *SCALE*	CHECKED -	REVISED -
PLOT DATE = *DATE*	DATE -	REVISED -



**Allen Henderson & Associates, Inc.**  
 Civil and Structural Engineers Springfield, IL  
 62703 Phone: (217)544-8033 IL Design Firm  
 No. 184-001907

**CROSS SECTIONS**  
 SCALE: 1" = 5' SHEET NO. 1 OF 8 SHEETS STA. 630+00.00 TO STA. 630+55.50

F.A.P. RTE.	SECTION	COUNTY	TOTAL SHEETS	SHEET NO.
685	(115)B-2	HANCOCK	28	21
CONTRACT NO. 72F07				
FED. ROAD DIST. NO. ILLINOIS FED. AID PROJECT				

DATE	
BY	
FINAL SURVEY	SURVEYED
NOTE BOOK	PLOTTED
NO.	TEMPLATE
	AREAS CHECKED
	AREAS CHECKED

DATE	
BY	
ORIGINAL SURVEY	SURVEYED
NOTE BOOK	PLOTTED
NO.	TEMPLATE
	AREAS CHECKED
	AREAS CHECKED

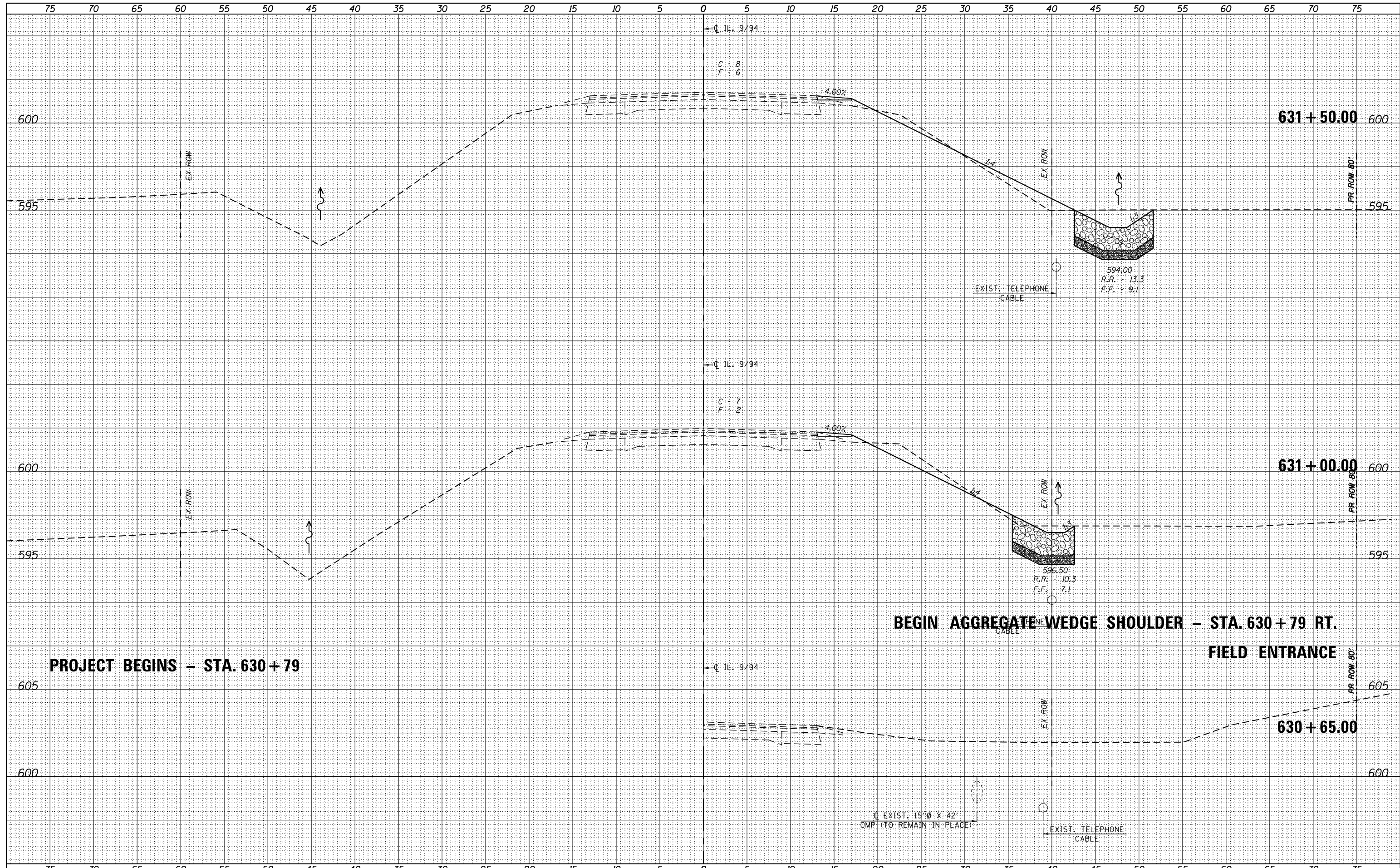

**PROJECT BEGINS - STA. 630+79**

**BEGIN AGGREGATE WEDGE SHOULDER - STA. 630+79 RT.**  
**FIELD ENTRANCE**

FILE NAME =  
 \*FILEL\*

USER NAME = \*USER\*  
 PLOT SCALE = \*SCALE\*  
 PLOT DATE = \*DATE\*

DESIGNED -	REVISED -
DRAWN -	REVISED -
CHECKED -	REVISED -
DATE -	REVISED -



**Allen Henderson & Associates, Inc.**  
 Civil and Structural Engineers Springfield, IL  
 62703 Phone: (217)544-8033 IL Design Firm  
 No. 184-001907

**CROSS SECTIONS**  
 SCALE: 1" = 5'  
 SHEET NO. 1 OF 8 SHEETS  
 STA. 630+65.00 TO STA. 631+50.00

F.A.P. RTE.	SECTION	COUNTY	TOTAL SHEETS	SHEET NO.
685	(115)B-2	HANCOCK	28	22
CONTRACT NO. 72F07				
FED. ROAD DIST. NO. ILLINOIS FED. AID PROJECT				

**TRANSITION FORESLOPES FROM 1:4 AT  
STA. 632+50 TO 1:6.3 AT STA. 632+80 LT.**

**TRANSITION FORESLOPES FROM 1:6 AT  
STA. 632+50 TO 1:6.7 AT STA. 632+80 RT.**

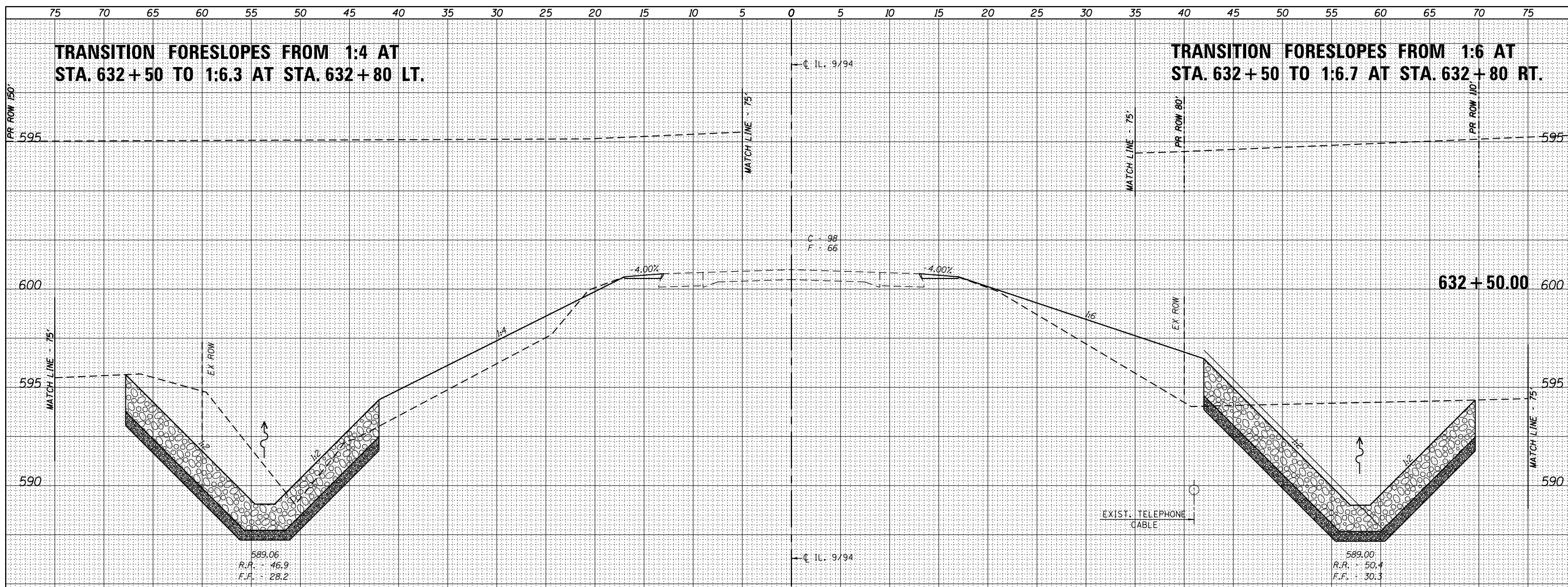

**BEGIN PAVEMENT REMOVAL AND HMA BASE COURSE - STA. 632+62**

**TRANSITION FORESLOPE FROM 1:4 AT  
STA. 632+00 TO 1:6 AT STA. 632+50 RT.**

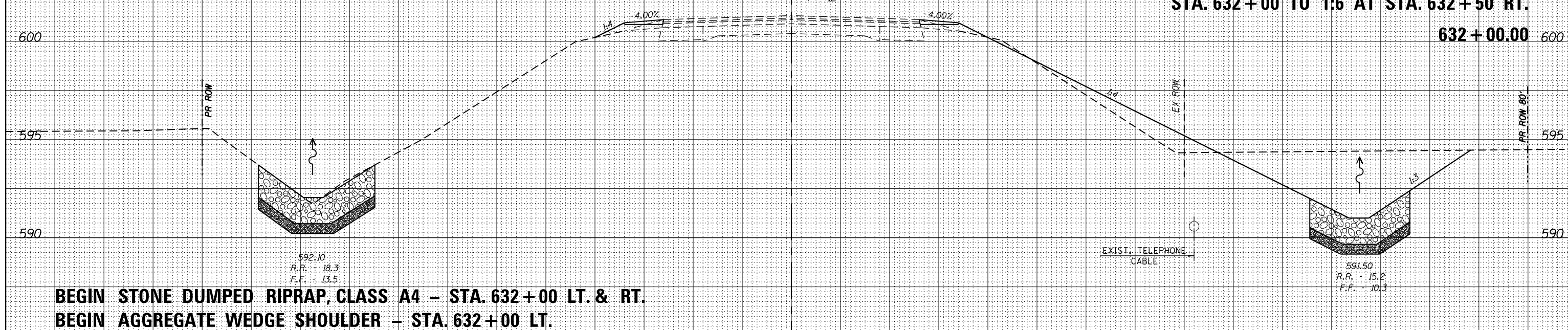

**BEGIN STONE DUMPED RIPRAP, CLASS A4 - STA. 632+00 LT. & RT.  
BEGIN AGGREGATE WEDGE SHOULDER - STA. 632+00 LT.**

DATE	
BY	
FINAL SURVEY	
SURVEYED	
PLOTTED	
TEMPLATE	
NOTE BOOK	
AREAS CHECKED	
AREAS CHECKED	

DATE	
BY	
ORIGINAL SURVEY	
SURVEYED	
PLOTTED	
TEMPLATE	
NOTE BOOK	
AREAS CHECKED	
AREAS CHECKED	

FILE NAME =	USER NAME = *USER*
*FILE#*	DESIGNED -
	DRAWN -
	CHECKED -
	DATE -

REVISOR -
REVISOR -
REVISOR -
REVISOR -

DESIGNED -	REVISOR -
DRAWN -	REVISOR -
CHECKED -	REVISOR -
DATE -	REVISOR -



**Allen Henderson & Associates, Inc.**  
Civil and Structural Engineers Springfield, IL.  
62703 Phone: (217)544-8033 IL Design Firm  
No. 184-001907

<b>CROSS SECTIONS</b>	
SCALE: 1" = 5'	SHEET NO. 1 OF 8 SHEETS
STA. 632+00.00 TO STA. 632+50.00	

F.A.P. RTE.	SECTION	COUNTY	TOTAL SHEETS	SHEET NO.
685	(115)B-2	HANCOCK	28	23
CONTRACT NO. 72F07				
FED. ROAD DIST. NO. ILLINOIS FED. AID PROJECT				

DATE	
BY	
FINAL SURVEY	SURVEYED
NOTE BOOK	PLOTTED
NO.	TEMPLATE
	AREAS CHECKED

DATE	
BY	
ORIGINAL SURVEY	SURVEYED
NOTE BOOK	PLOTTED
NO.	TEMPLATE
	AREAS CHECKED

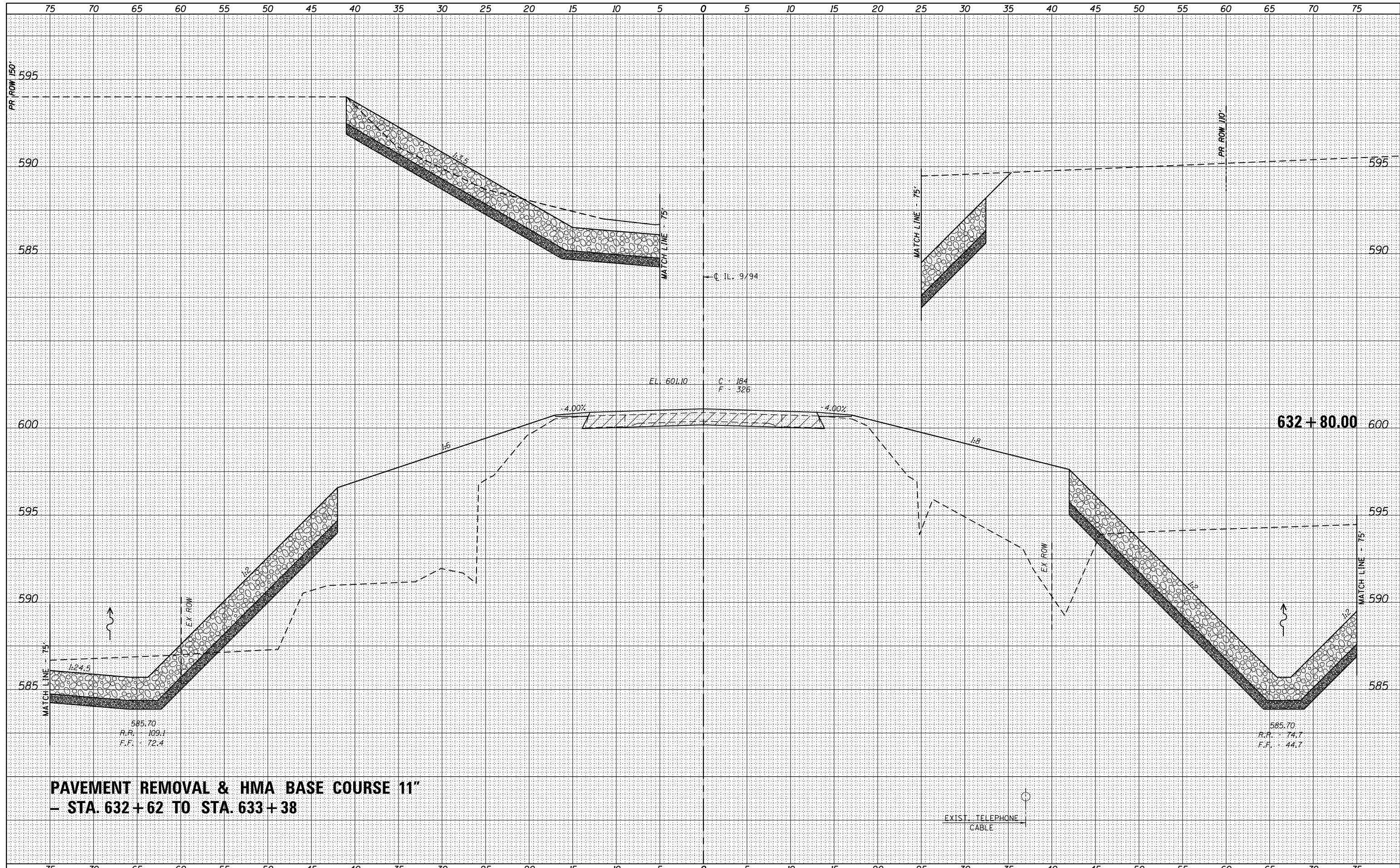

**PAVEMENT REMOVAL & HMA BASE COURSE 11"**  
**- STA. 632+62 TO STA. 633+38**

FILE NAME	USER NAME
*FILEL*	*USERS*
	DESIGNED
	REVIS
	REVIS
	REVIS
	REVIS
	REVIS

DESIGNED	-
DRAWN	-
CHECKED	-
DATE	-

REVIS	-
REVIS	-
REVIS	-
REVIS	-



**Allen Henderson & Associates, Inc.**  
 Civil and Structural Engineers Springfield, IL  
 62703 Phone: (217)544-8033 IL Design Firm  
 No. 184-001907

SCALE: 1" = 5'		SHEET NO. 1 OF 8 SHEETS		STA. 632+80.00 TO STA. 632+80.00	
----------------	--	-------------------------	--	----------------------------------	--

EXIST. TELEPHONE  
CABLE

F.A.P. RTE.	SECTION	COUNTY	TOTAL SHEETS	SHEET NO.
685	(115)B-2	HANCOCK	28	24
FED. ROAD DIST. NO.			ILLINOIS FED. AID PROJECT	
			CONTRACT NO. 72F07	



DATE	
BY	
SURVEYED	
PLOTTED	
TEMPLATE	
NOTE BOOK	
AREAS CHECKED	
AREAS CHECKED	

DATE	
BY	
SURVEYED	
PLOTTED	
TEMPLATE	
NOTE BOOK	
AREAS CHECKED	
AREAS CHECKED	

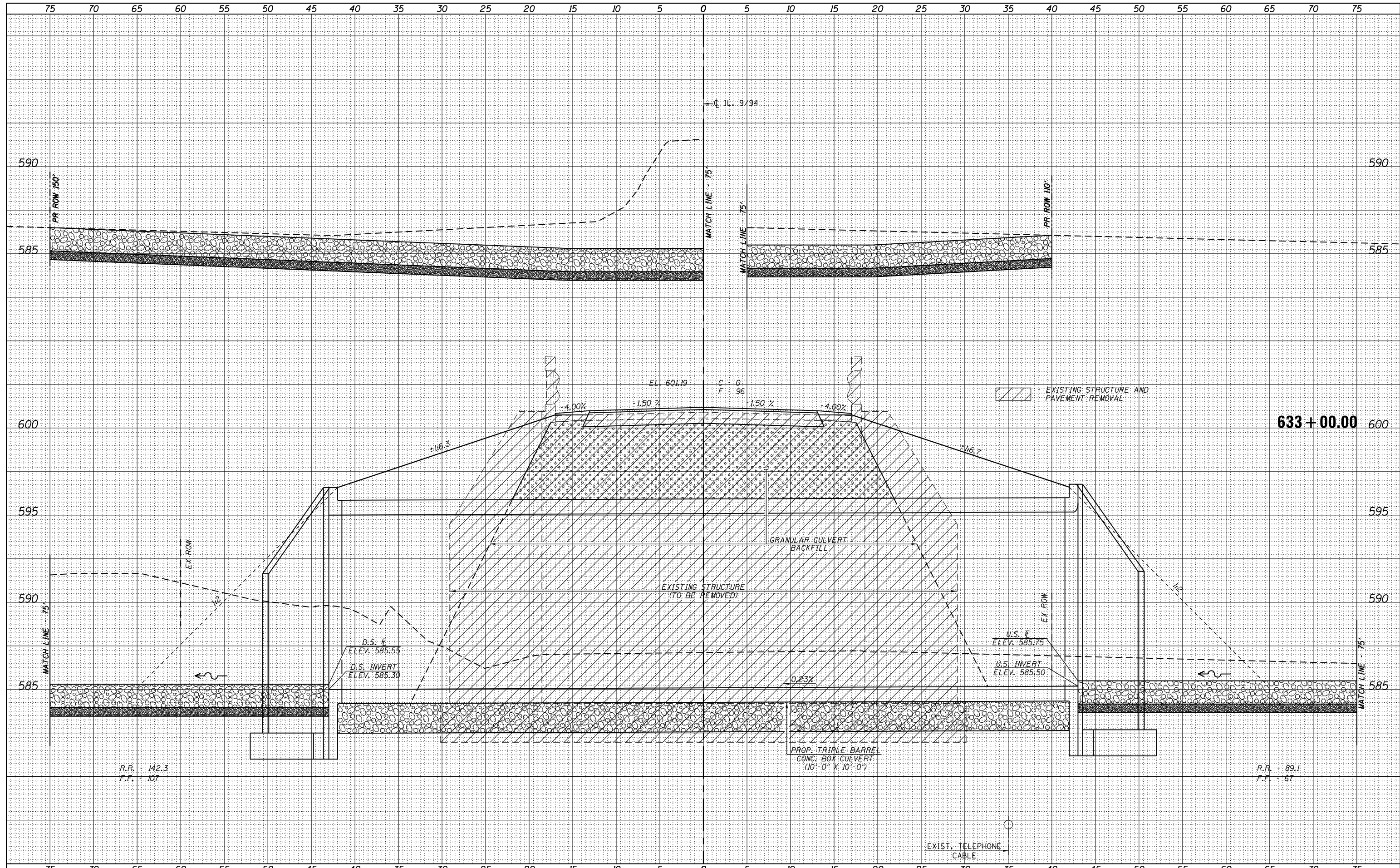

FILE NAME =  
 \*FILE#\*

USER NAME = \*USER#\*  
 PLOT SCALE = \*SCALE#\*  
 PLOT DATE = \*DATE#\*

DESIGNED -  
 DRAWN -  
 CHECKED -  
 DATE -

REVISED -  
 REVISED -  
 REVISED -  
 REVISED -

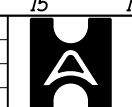

**Allen Henderson & Associates, Inc.**  
 Civil and Structural Engineers Springfield, IL  
 62703 Phone: (217)544-8033 IL Design Firm  
 No. 184-001907

**CROSS SECTIONS**  
 SCALE: 1" = 5'  
 SHEET NO. 1 OF 8 SHEETS  
 STA. 633+00.00 TO STA. 633+00.00

F.A.P. RTE.	SECTION	COUNTY	TOTAL SHEETS	SHEET NO.
685	(115)B-2	HANCOCK	28	25
CONTRACT NO. 72F07				
FED. ROAD DIST. NO. ILLINOIS FED. AID PROJECT				

DATE	
BY	
FINAL SURVEY	
PLOTTED	
TEMPLATE	
NOTE BOOK	
AREAS CHECKED	
NO.	

DATE	
BY	
ORIGINAL SURVEY	
PLOTTED	
TEMPLATE	
NOTE BOOK	
AREAS CHECKED	
NO.	

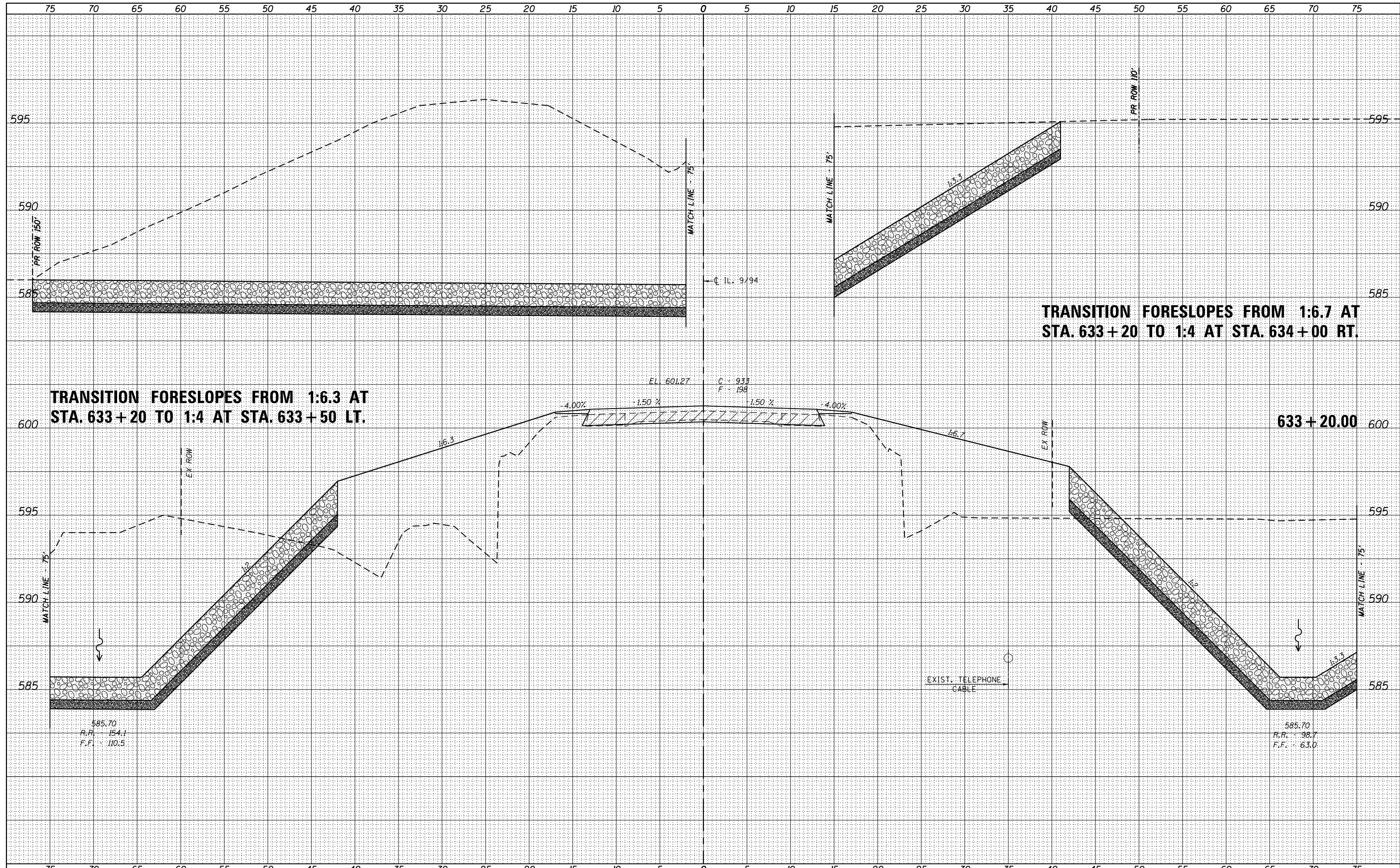

FILE NAME =	USER NAME = *USER*	DESIGNED -	REVISD -		<b>Allen Henderson &amp; Associates, Inc.</b> Civil and Structural Engineers Springfield, IL 62703 Phone: (217)544-8033 IL Design Firm No. 184-001907	<b>CROSS SECTIONS</b>		F.A.P. RTE.	SECTION	COUNTY	TOTAL SHEETS	SHEET NO.
*FILE#*		DRAWN -	REVISD -			685	(115)B-2	HANCOCK	28	26		
		CHECKED -	REVISD -			CONTRACT NO. 72F07						
		DATE -	REVISD -			FED. ROAD DIST. NO. ILLINOIS FED. AID PROJECT						
				SCALE: 1" = 5'	SHEET NO. 1 OF 8 SHEETS	STA. 633+20.00 TO STA. 633+20.00						

DATE \_\_\_\_\_  
 BY \_\_\_\_\_  
 SURVEYED \_\_\_\_\_  
 PLOTTED \_\_\_\_\_  
 TEMPLATE \_\_\_\_\_  
 NOTE BOOK \_\_\_\_\_  
 AREAS CHECKED \_\_\_\_\_  
 NO. \_\_\_\_\_

DATE \_\_\_\_\_  
 BY \_\_\_\_\_  
 SURVEYED \_\_\_\_\_  
 PLOTTED \_\_\_\_\_  
 TEMPLATE \_\_\_\_\_  
 NOTE BOOK \_\_\_\_\_  
 AREAS CHECKED \_\_\_\_\_  
 NO. \_\_\_\_\_

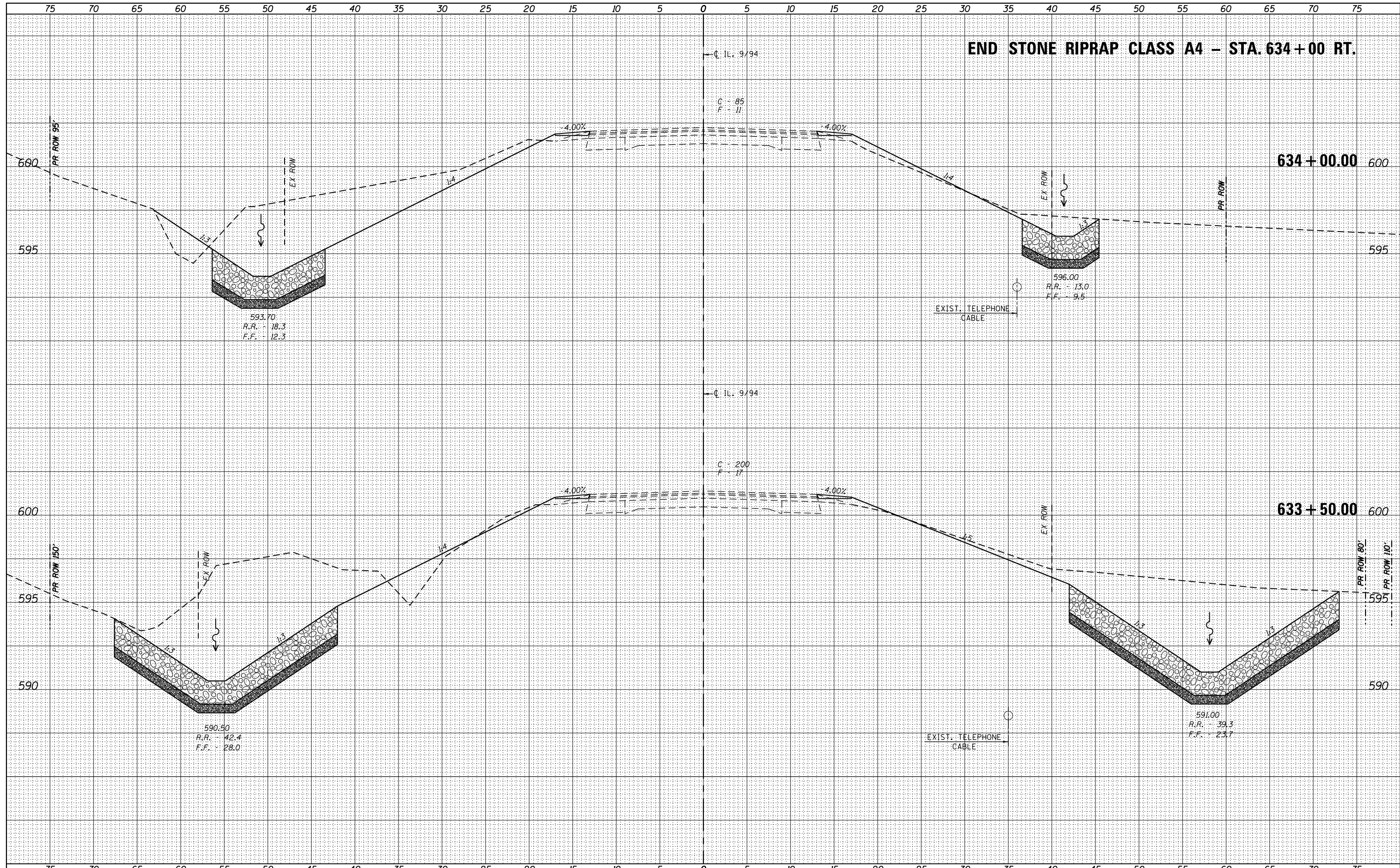

**END STONE RIPRAP CLASS A4 - STA. 634+00 RT.**

FILE NAME = \_\_\_\_\_  
 \*FILE#\* \_\_\_\_\_

USER NAME = \*USER#\* \_\_\_\_\_  
 PLOT SCALE = \*SCALE#\* \_\_\_\_\_  
 PLOT DATE = \*DATE#\* \_\_\_\_\_

DESIGNED - \_\_\_\_\_  
 DRAWN - \_\_\_\_\_  
 CHECKED - \_\_\_\_\_  
 DATE - \_\_\_\_\_

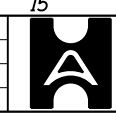

**Allen Henderson & Associates, Inc.**  
 Civil and Structural Engineers Springfield, IL  
 62703 Phone: (217)544-8033 IL Design Firm  
 No. 184-001907

**CROSS SECTIONS**  
 SCALE: 1" = 5'  
 SHEET NO. 1 OF 8 SHEETS  
 STA. 633+50.00 TO STA. 634+00.00

F.A.P. RTE.	SECTION	COUNTY	TOTAL SHEETS	SHEET NO.
685	(115)B-2	HANCOCK	28	27
CONTRACT NO. 72F07				
FED. ROAD DIST. NO. ILLINOIS FED. AID PROJECT				

DATE	
BY	
FINISHED SURVEY	
PLOTTED	
TEMPLATE	
NOTE BOOK	
AREAS CHECKED	
NO.	

DATE	
BY	
ORIGINAL SURVEY	
PLOTTED	
TEMPLATE	
NOTE BOOK	
AREAS CHECKED	
NO.	

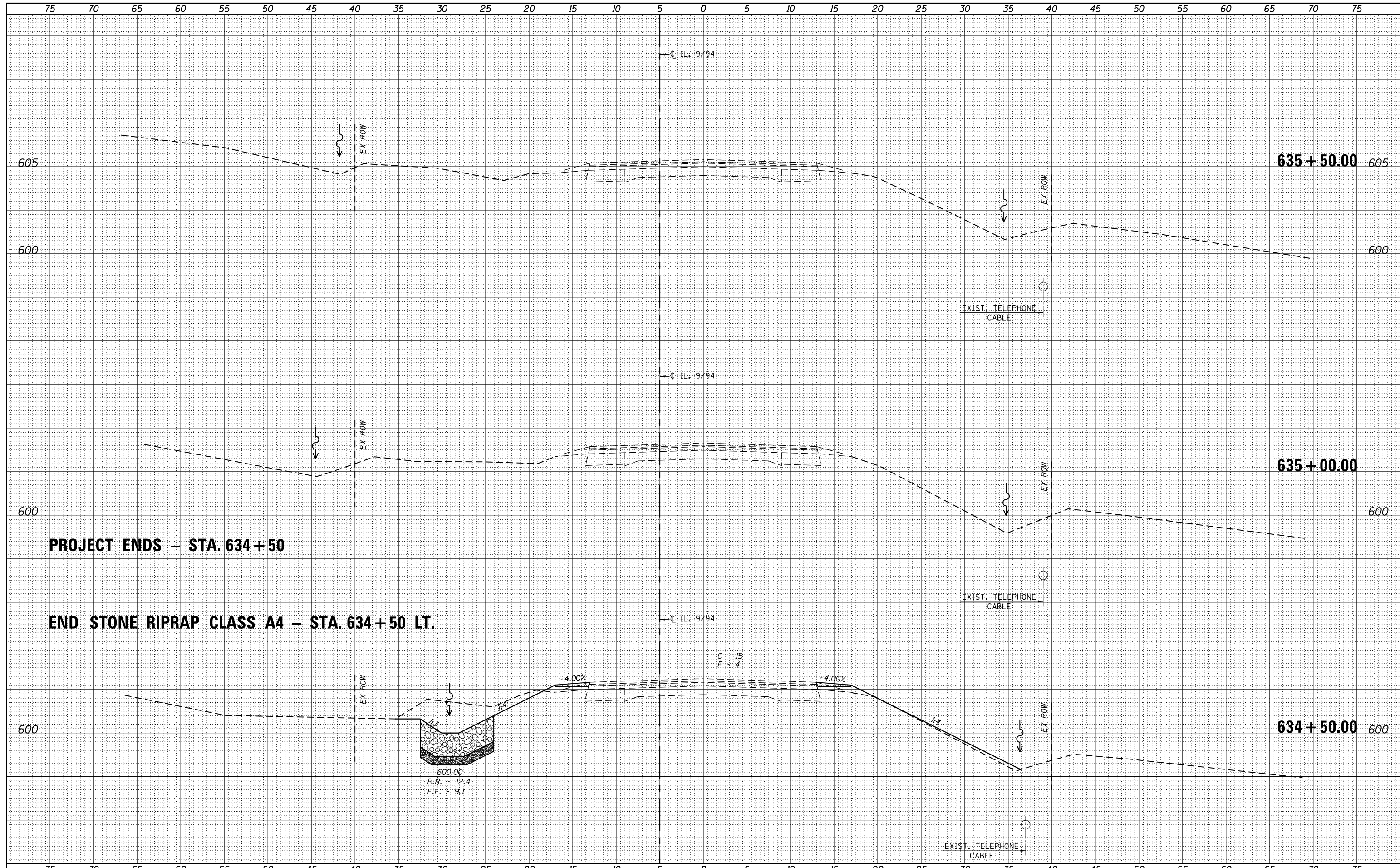

PROJECT ENDS - STA. 634 + 50

END STONE RIPRAP CLASS A4 - STA. 634 + 50 LT.

FILE NAME =  
\*FILEL\*

USER NAME = \*USERS\*  
PLOT SCALE = \*SCALE\*  
PLOT DATE = \*DATE\*

DESIGNED -  
DRAWN -  
CHECKED -  
DATE -

REVISED -  
REVISED -  
REVISED -  
REVISED -



Allen Henderson & Associates, Inc.  
Civil and Structural Engineers Springfield, IL.  
62703 Phone: (217)544-8033 IL Design Firm  
No. 184-001907

**CROSS SECTIONS**  
SCALE: 1" = 5'  
SHEET NO. 1 OF 8 SHEETS  
STA. 634+50.00 TO STA. 635+50.00

F.A.P. RTE.	SECTION	COUNTY	TOTAL SHEETS	SHEET NO.
685	(115)B-2	HANCOCK	28	28
CONTRACT NO. 72F07				
FED. ROAD DIST. NO. ILLINOIS FED. AID PROJECT				