

PARTIAL PLAN
(Unit A as shown, Unit B similar)

Notes:
See Sheet S12 for superstructure details and Bill of Material.
Bars indicated thus 26x4- #5 etc. indicates 26 lines of bars with 4 lengths per line.
See Sheet S12 for edge of deck reinforcement.
The deck joint opening dimension at the Abutments is based on a Rolled Rail Strip Seal Joint. If the Contractor elects to use the Welded Rail Strip Seal Joint, deck dimensions may require adjustments to satisfy the details on Base Sheet EJ-SSJ.

* See Sheet S24 for bar splicers at stage construction line.

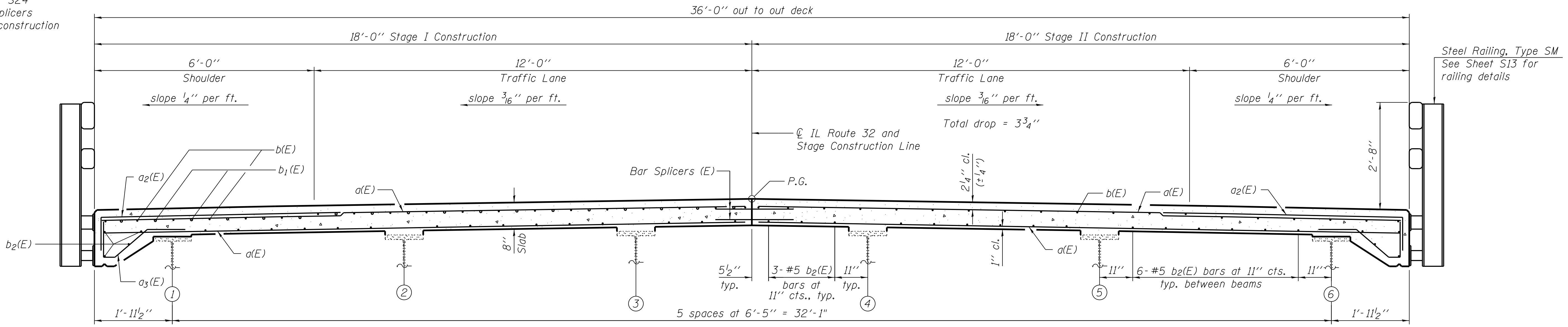

CROSS SECTION
(Looking South)

NEAR PIER

NEAR MIDSPAN

FILE NAME = \\N1736\active\17363009_1.DOT_IL32.cover_LakeShelby\11a\structural\drawing\0700015_74357_011.Deck.dgn



USER NAME = jerojas	DESIGNED - JSR	REVISED -
PLOT SCALE = N/A	CHECKED - BHS	REVISED -
PLOT DATE = 9/16/2014	DRAWN - MJB	REVISED -
	CHECKED - BPS	REVISED -

STATE OF ILLINOIS
DEPARTMENT OF TRANSPORTATION

DECK PLAN AND SECTION
STRUCTURE NO. 070-0015

SHEET NO. S11 OF 28 SHEETS

F.A.P. RTE.	SECTION	COUNTY	TOTAL SHEETS	SHEET NO.
762	(2BR)BR-1	MOULTRIE	48	31
CONTRACT NO. 74357				
ILLINOIS FED. AID PROJECT				