

FILE NAME = I:\100\6008 - d7 var var-work order 3 - 11.121 resurfacing\CADD\Structural\misc\dtds.dgn

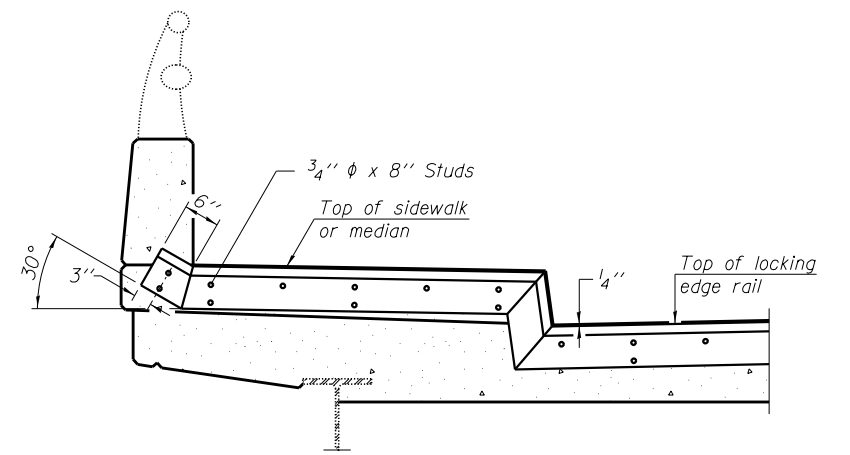

**TYPICAL END TREATMENT AT SIDEWALK OR MEDIAN**  
 Shorter plates with a single row of studs at 12" cts. may be necessary on medians which are shallower than 9". See manufacturer's recommendation.

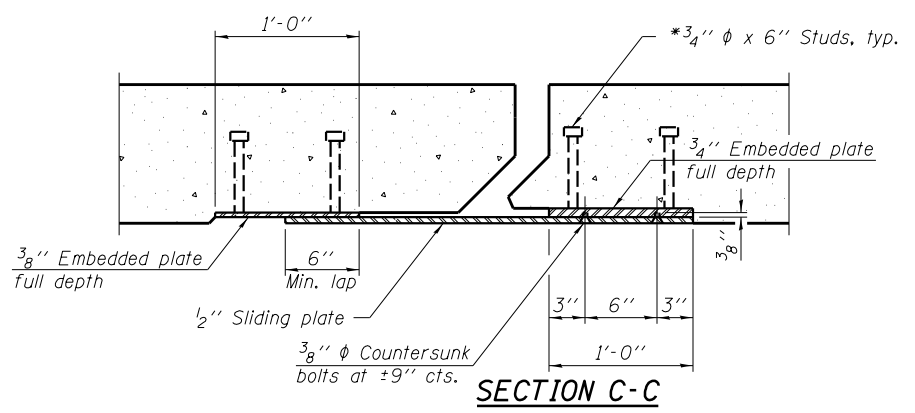
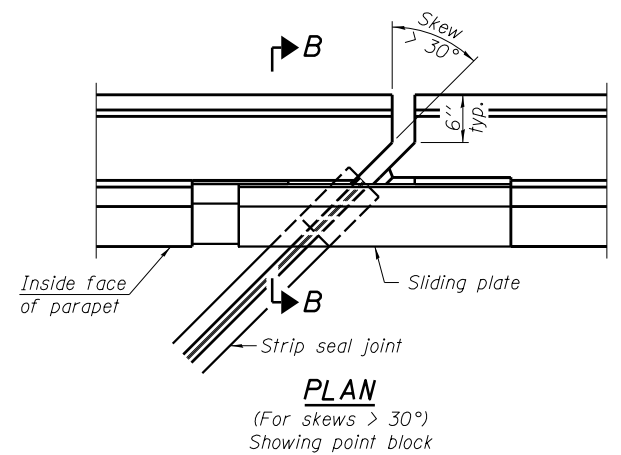
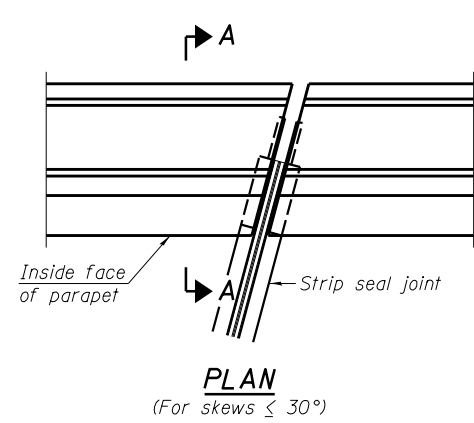
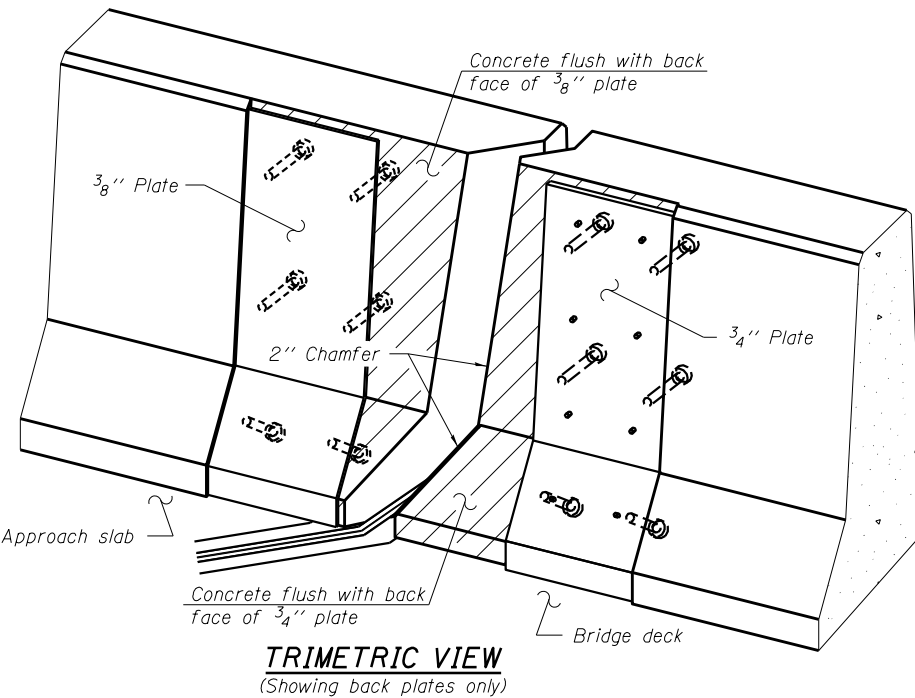
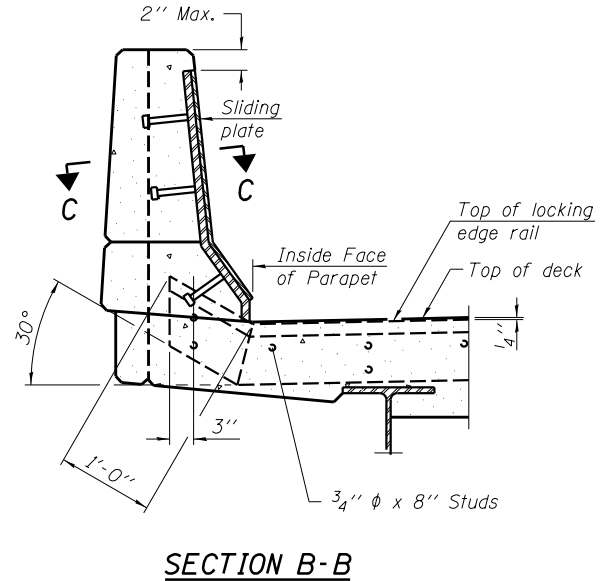
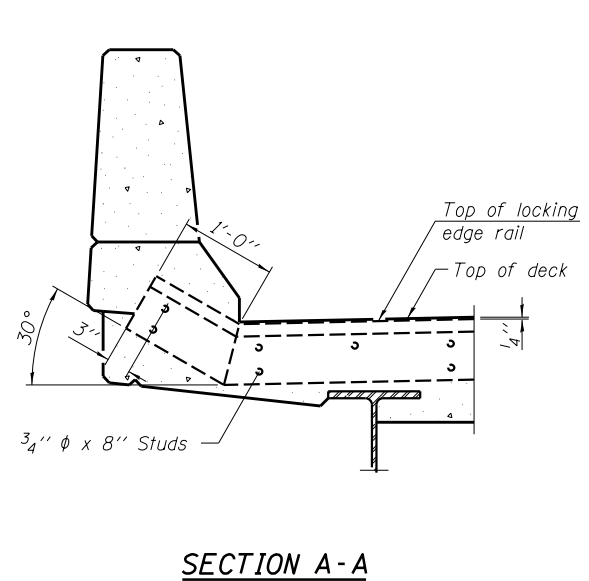

**Notes:**  
 The strip seal shall be made continuous and shall have a minimum thickness of 1/4". The configuration of the strip seal shall match the configuration of the Locking Edge Rails. Open or "webbed" strip seal gland configurations are not permitted. The gland shall be sized for a maximum rated movement of 4 inches.  
 The Locking Edge Rails depicted are conceptual only, except for the minimum dimensions shown. The actual configuration of the Locking Edge Rails and matching strip seal may vary from manufacturer to manufacturer. Flanged edge rails will not be allowed. Locking Edge Rails may be spliced at slope discontinuities.  
 The manufacturer's recommended installation methods shall be followed.  
 The joint opening and deck dimensions detailed on the superstructure are based on a rolled rail expansion joint. If the Contractor elects to use the welded rail expansion joint, the opening and deck dimensions shall be modified according to the dimensions detailed on this sheet. Required modifications shall be made at no additional cost to the State.  
 All steel components shall be galvanized after fabrication according to Article 520.03 of the Standard Specifications. Maximum space between rail segments shall be 3/16", sealed with a suitable sealant. Joints in rails within 10 ft. of curbs shall be welded.  
 Parapet plates and anchorage studs for skews > 30 degrees included in the cost of Preformed Joint Strip Seal.

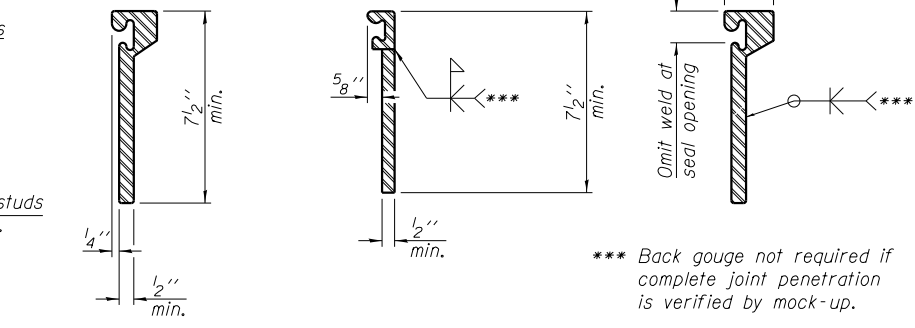
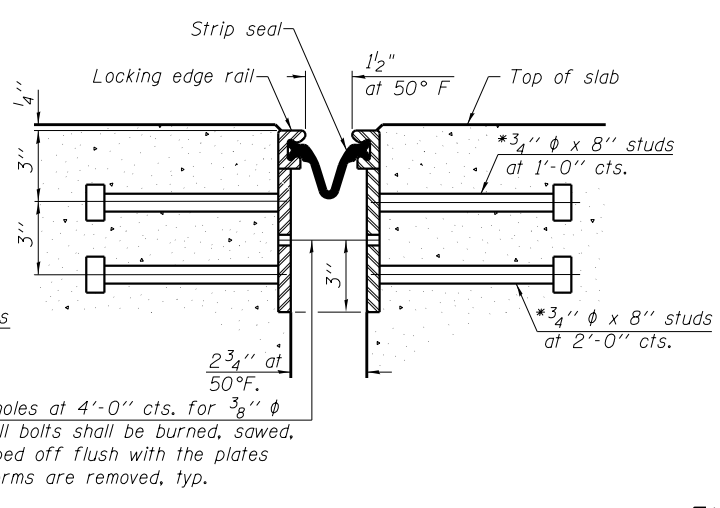
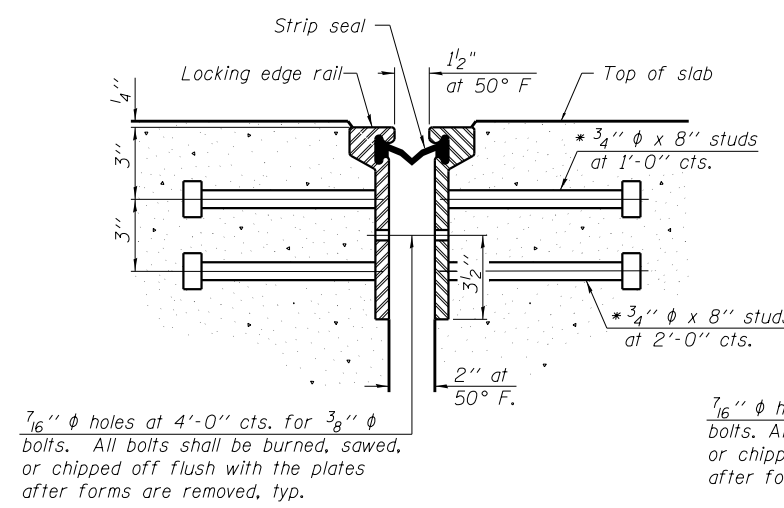

\*\*\* Back gouge not required if complete joint penetration is verified by mock-up.

**LOCKING EDGE RAIL SPLICE**  
 The inside of the locking edge rail groove shall be free of weld residue.  
 Rolled rail shown, welded rail similar.

\* Granular or solid flux filled headed studs conforming to Article 1006.32 of the Std. Specs., automatically end welded.

**LOCKING EDGE RAILS**

**BILL OF MATERIAL**

Item	Unit	Total
Preformed Joint Strip Seal	Foot	235