

DETAILS OF SURFACING AT INTERSECTIONS AND SIDEROADS

F.A.S.	SECTION	COUNTY	TOTAL SHEETS	SHEET NO.
883	06-00102-00-RS	WHITE	6	4
FED. ROAD DIST. NO. 1		ILLINOIS	NORRIS CITY WEST	
LEC JOB # H081002WH		CONTRACT # 99348		

DETAIL OF INTERSECTION LT. STA. 127+54

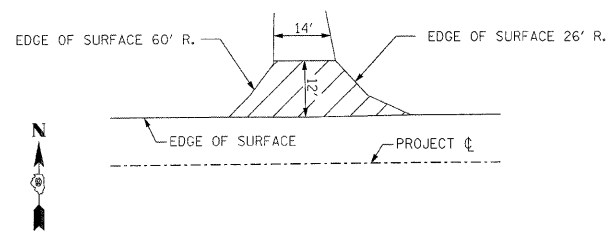

PROFILE LT

NOTE: THE QUANTITY SHOWN FOR HOT-MIX ASPHALT SURFACE COURSE, MIX "C", N50 INCLUDES 9.1 TONS OF MATERIAL FOR THE SIDEROAD APPROACH AND RADII.

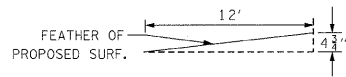

DETAIL OF INTERSECTION RT. STA. 128+87

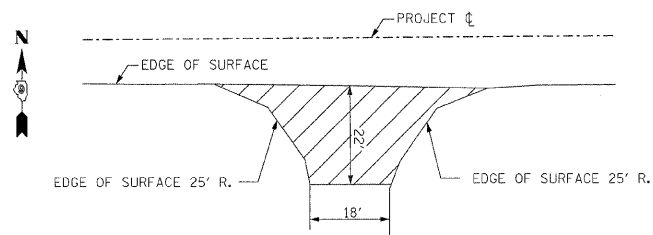

PROFILE RT

NOTE: THE QUANTITY SHOWN FOR HOT-MIX ASPHALT SURFACE COURSE, MIX "C", N50 INCLUDES 20.1 TONS OF MATERIAL FOR THE SIDEROAD APPROACH AND RADII.

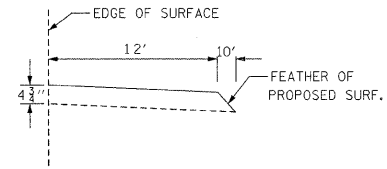

DETAIL OF INTERSECTION RT. STA. 132+50 AND LT. STA. 132+50

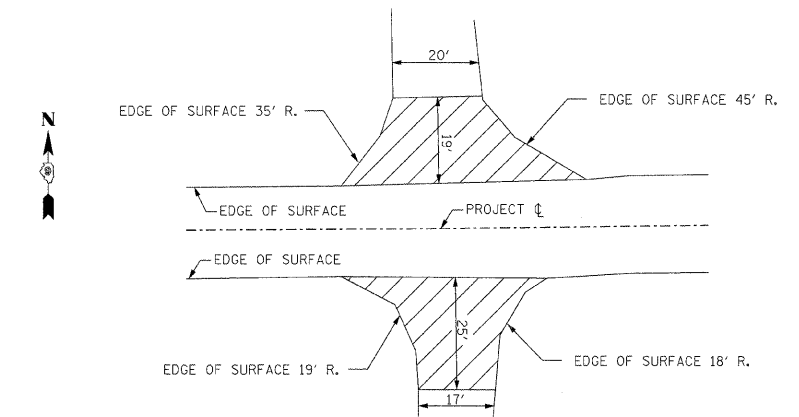

PROFILE LT

PROFILE RT

NOTE: THE QUANTITY SHOWN FOR HOT-MIX ASPHALT SURFACE COURSE, MIX "C", N50 INCLUDES 17.5 TONS OF MATERIAL FOR THE SIDEROAD RT. APPROACH AND RADII. IT ALSO INCLUDES 19.1 TONS OF MATERIAL FOR THE SIDEROAD LT. APPROACH AND RADII.

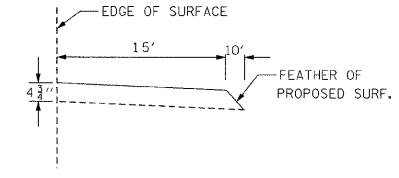
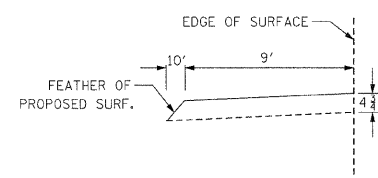

DETAIL OF INTERSECTION RT. STA. 136+38 AND LT. STA. 136+38

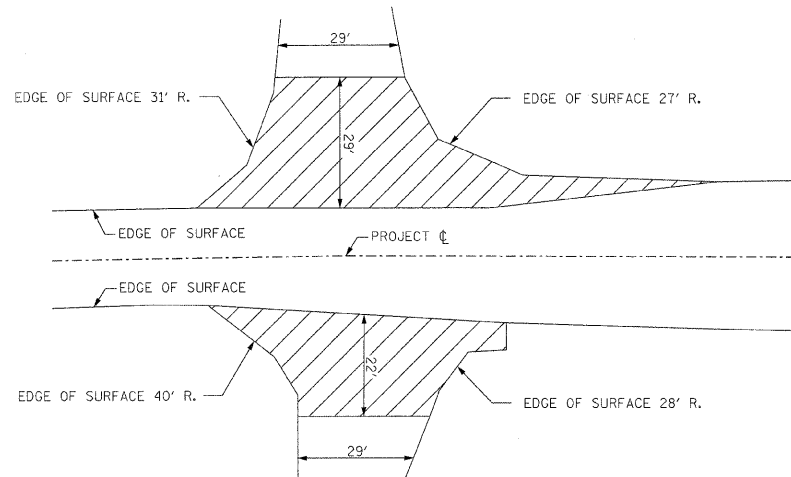

PROFILE RT

PROFILE LT

NOTE: THE QUANTITY SHOWN FOR HOT-MIX ASPHALT SURFACE COURSE, MIX "C", N50 INCLUDES 28.9 TONS OF MATERIAL FOR THE SIDEROAD RT. APPROACH AND RADII. IT ALSO INCLUDES 44.5 TONS OF MATERIAL FOR THE SIDEROAD LT. APPROACH AND RADII.

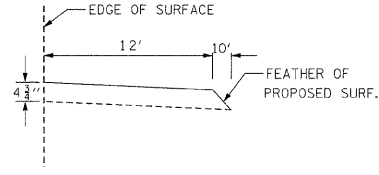
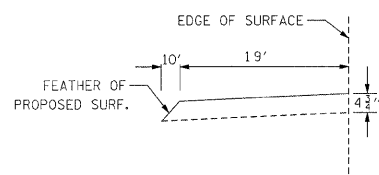

DETAIL OF MILL STA. 137+50 TO STA. 139+68

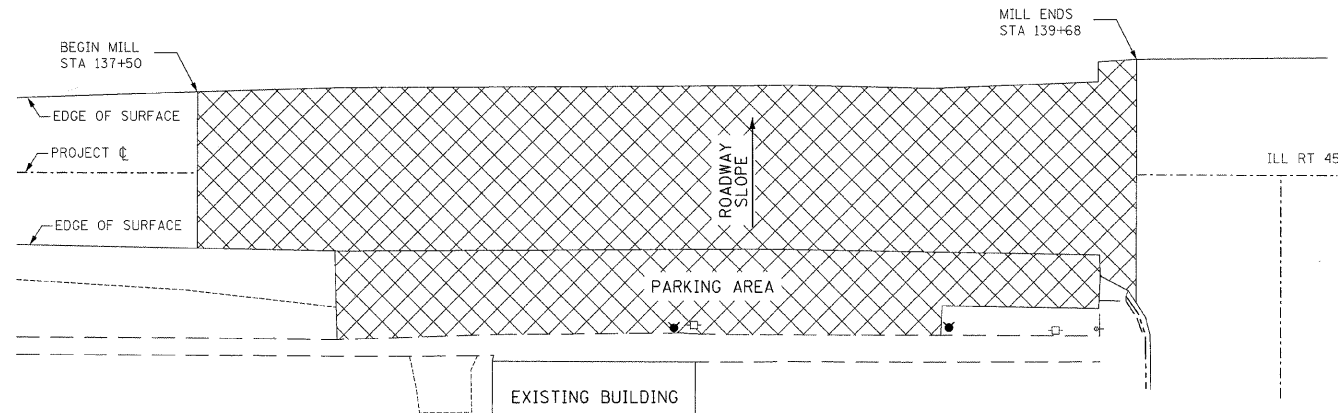

TYPICAL CROSS SECTION PROPOSED STA 137+60 TO STA 139+68

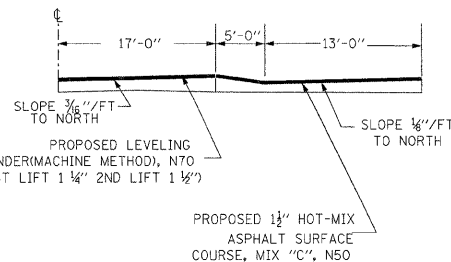

NOTE: THE QUANTITY SHOWN FOR HOT-MIX ASPHALT SURFACE COURSE, MIX "C", N50 INCLUDES 30 TONS OF MATERIAL FOR THE PARKING AREA.

TEMPORARY RAMP DETAIL STA 139+18 TO STA 139+68

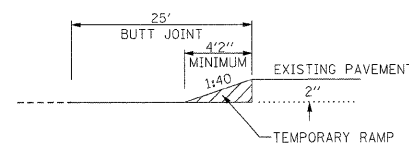

NOTE: THE PARKING AREA AND THE ROADWAY SHALL BE MILLED TWO INCHES AS SHOWN OR PER ENGINEER. THE PROPOSED PAVEMENT SHALL MATCH EXISTING AT THE EDGE OF SIDEWALK IN THE PARKING AREA AND SLOPE TOWARD THE ROADWAY. A PROPOSED SWALE SHALL BE PLACED 5' OUTSIDE OF THE ROADWAY FOR DRAINAGE. SOME AREAS OF CONCRETE ARE WITHIN THE PARKING AREA AND WILL BE MILLED.

BUTT JOINT DETAIL STA 139+18 TO STA 139+68

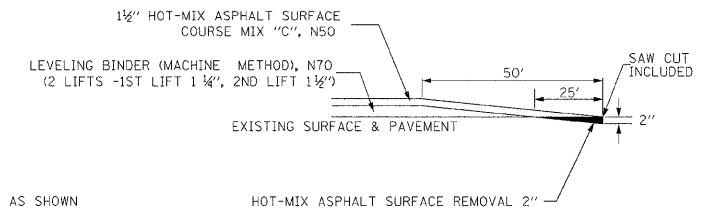

323 W. 3RD ST.
P.O. BOX 160
MT. CARMEL, IL
62863
PHONE:
(618)-262-8651
FAX:
(618)-263-3327

405 W STATE ST.
SUITE 1
PRINCETON, IN
47670
PHONE:
(812)-386-7611
FAX:
(812)-385-2812



PROFESSIONAL DESIGN FIRM
LAND SURVEY & PROFESSIONAL ENGINEERING CORPORATION
184-00887
(62-032435)(35-002769)



AARON M. MEFFORD
NAME
Aaron M. Mefford
SIGNATURE
10-2-08
DATE
11-30-09
EXPIRES