

**EXISTING TYPICAL CROSS SECTION**  
THATCHER AVENUE  
STATION 4+35 TO STATION 6+15

**TYPICAL CROSS SECTION LEGEND**

- ① COMBINATION CURB & GUTTER REMOVAL AS NOTED ON PLANS
- ② ROADWAY LIGHT POLE, 35' MOUNTING HEIGHT WITH 8' OR 12' MAST ARM AT APPROXIMATELY 180' SPACING
- ③ SIDEWALK AREA, PORTLAND CEMENT CONCRETE OR ASPHALT AS NOTED ON PLANS. REMOVAL TO BE PAID FOR AS SIDEWALK REMOVAL OR EARTH EXCAVATION AS NOTED ON PLANS
- ④ HOT-MIX ASPHALT SURFACE REMOVAL, 1-1/4" (WHERE COMBINATION CONCRETE CURB & GUTTER IS REMOVED)
- ⑤ 2" CRUSHED STONE (COST IS INCLUDED IN PCC SIDEWALK, 5", PCC BASE COURSE, 3", PCC BASE COURSE, 7", OR COMBINATION CONCRETE CURB & GUTTER, TYPE B-6.12 (MODIFIED) ITEMS)
- ⑥ AGGREGATE BASE COURSE, TYPE B, 4"
- ⑦ COMBINATION CONCRETE CURB & GUTTER, TYPE B-6.12 (MODIFIED)
- ⑧ HOT-MIX ASPHALT SURFACE COURSE, MIX C, N70, 1-1/2", IL-9.5 MM
- ⑨ PORTLAND CEMENT CONCRETE SIDEWALK, 5"
- ⑩ DECORATIVE BRICK SIDEWALK
- ⑪ DECORATIVE LIGHT POLE, ALUMINUM, 12' MOUNTING HEIGHT WITH DECORATIVE ACORN STYLE LUMINAIRE, SODIUM VAPOR, TENON MOUNT, 70 WATT (3 PER BLOCK)
- ⑫ PORTLAND CEMENT CONCRETE BASE COURSE, 3"

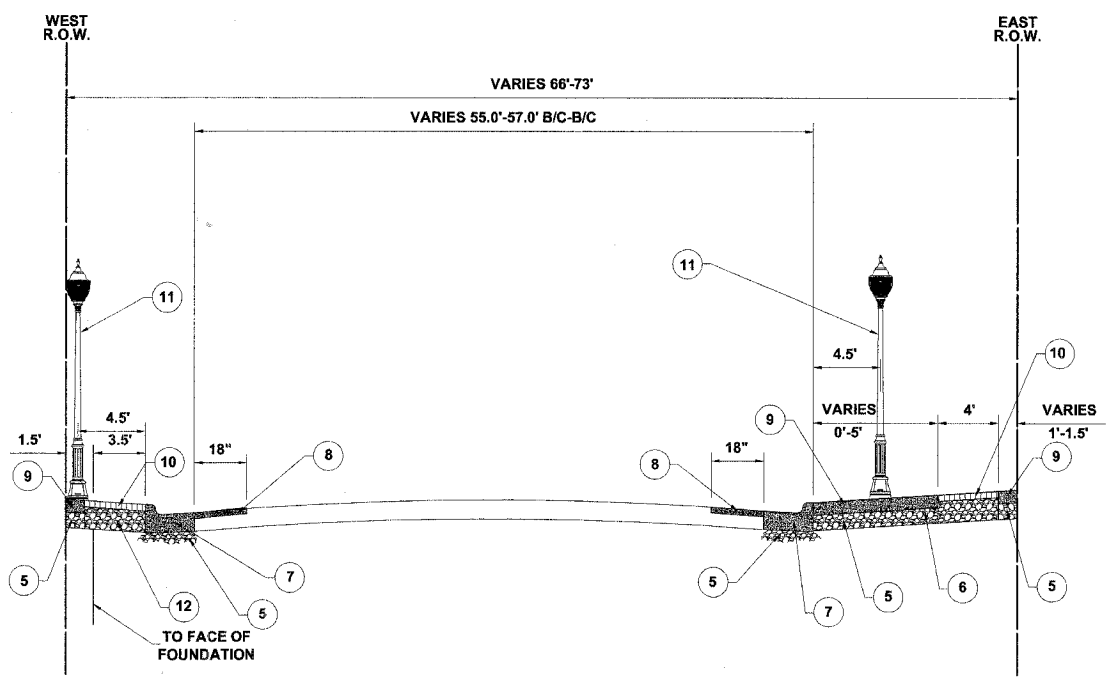

**PROPOSED TYPICAL CROSS SECTION**  
THATCHER AVENUE  
STATION 4+35 TO STATION 6+15

**HOT-MIX ASPHALT (HMA) MIXTURE REQUIREMENTS**

ITEM	A C TYPE	VOIDS
HMA SURFACE COURSE, MIX C, N70, 1-1/2", IL-9.5 MM	PG 64-22	4% @ 70 GYR.

THE UNIT WEIGHT USED TO CALCULATE ALL HMA SURFACE COURSE IS 112 LBS/SQYD/IN. WHEN RAP EXCEEDS 20%, THE NEW ASPHALT BINDER IN THE MIX SHALL BE PG 58-22.

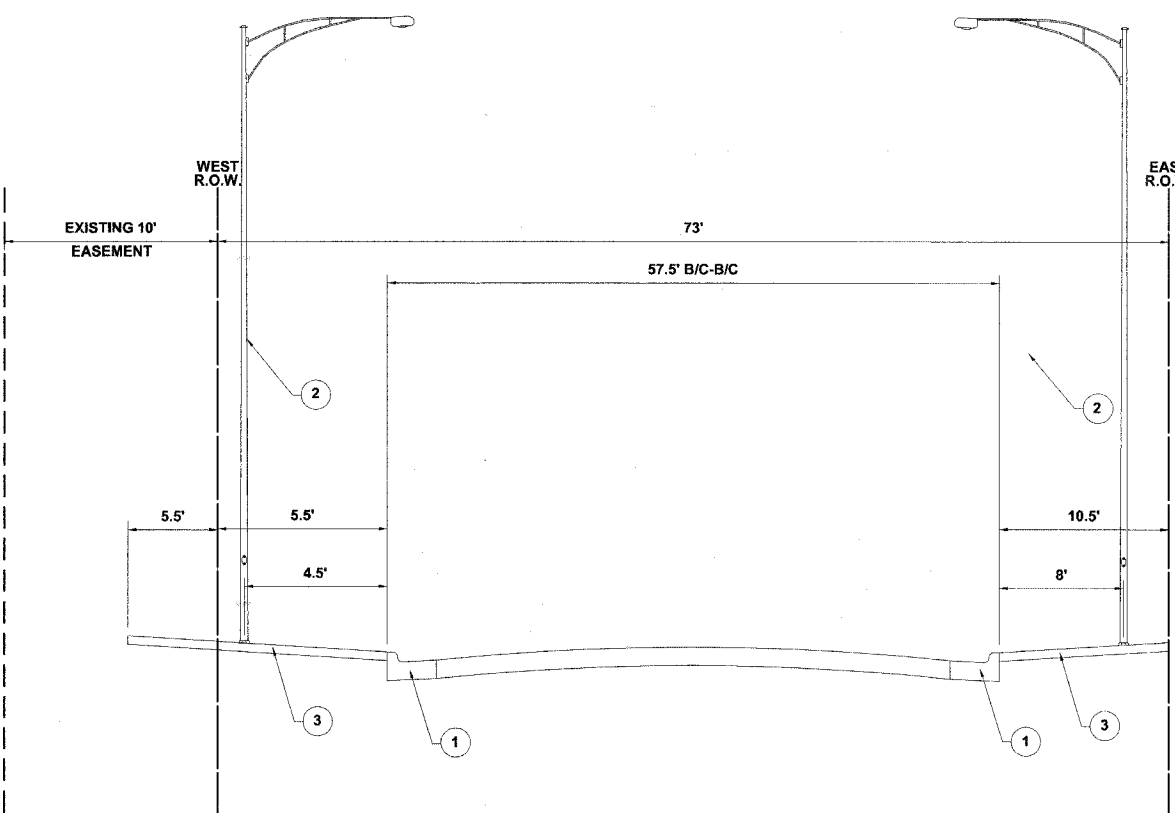

**EXISTING TYPICAL CROSS SECTION**  
THATCHER AVENUE  
STATION 6+15 TO STATION 8+00

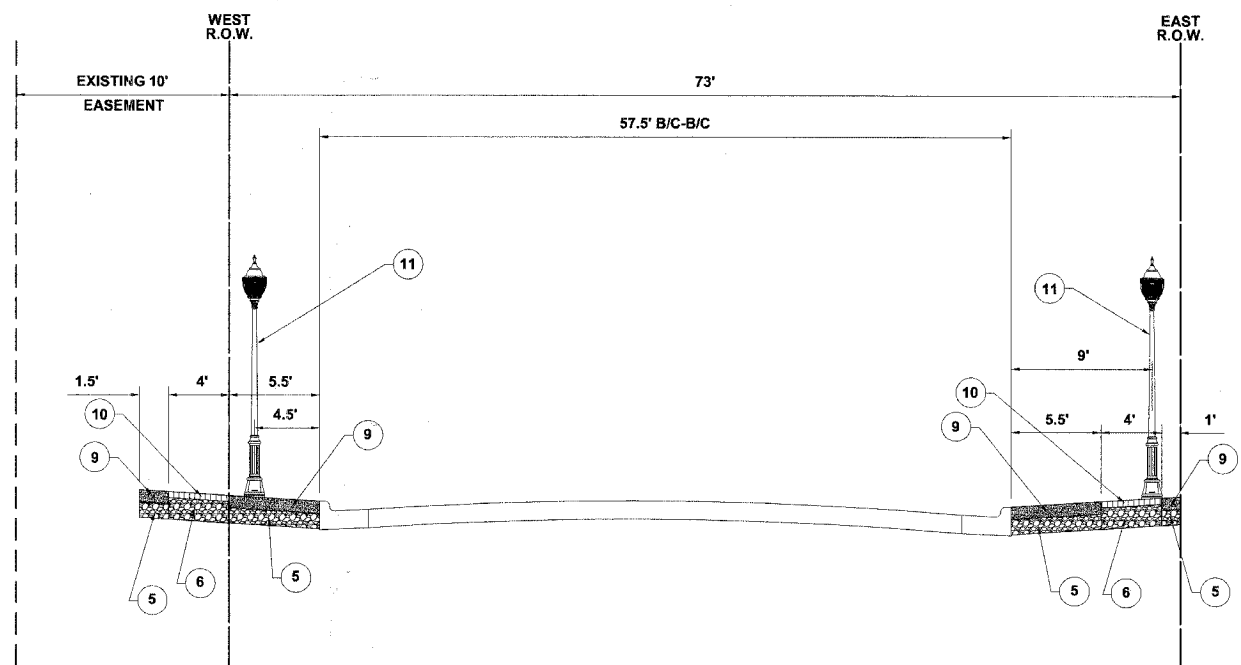

**PROPOSED TYPICAL CROSS SECTION**  
THATCHER AVENUE  
STATION 6+15 TO STATION 8+00

Drawing File: W:\Projects\76006033 - Grand Ave Streetscape\Typicals.dwg Oct 17, 2007 - 2:22pm