

F.A. RTE.	SECTION	COUNTY	TOTAL SHEETS	SHEET NO.
2993	05-00094-00-WR	DODGE	67	56
STA.		TO STA.		
FED. ROAD DIST. NO. 1		ILLINOIS FED. AID PROJECT		
PROJECT NO.: M-8003 (707)				

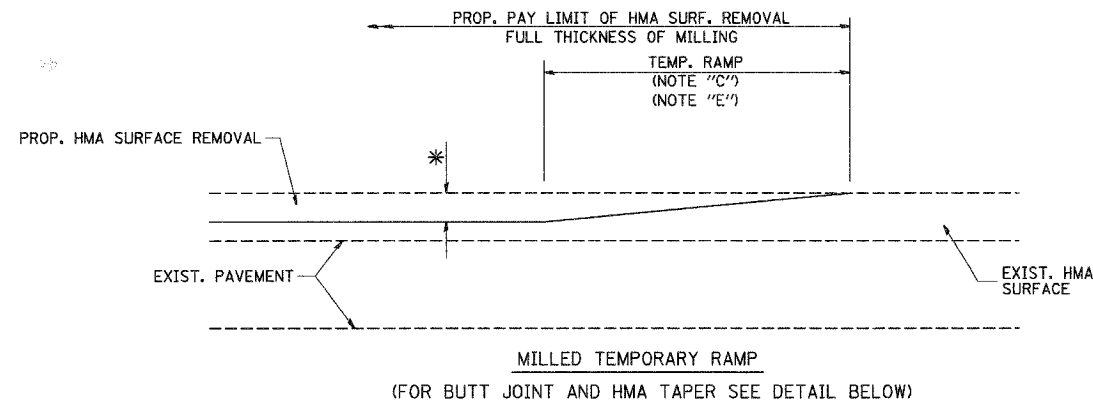

OPTION 1

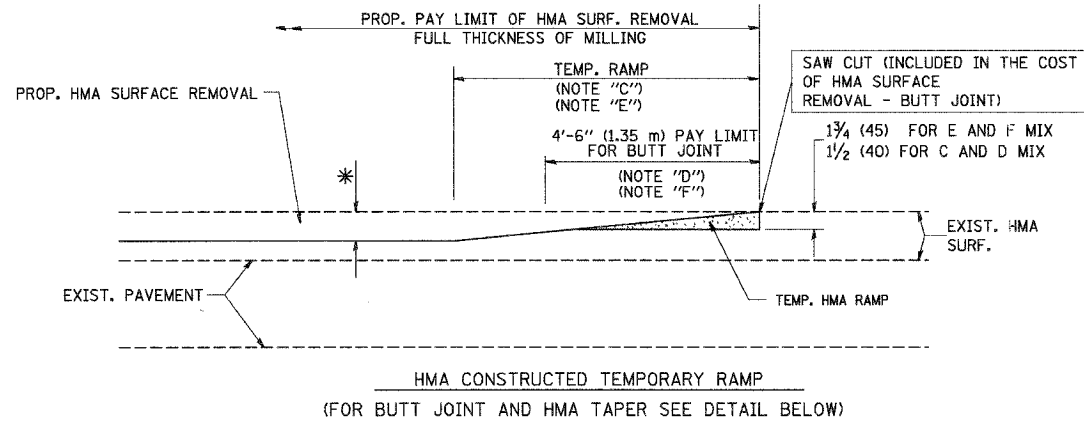

OPTION 2  
TYPICAL TEMPORARY RAMP

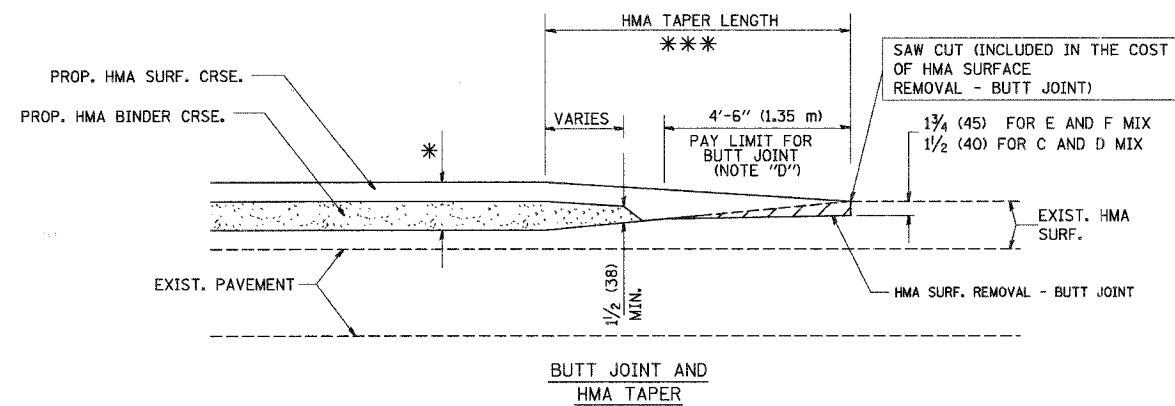

TYPICAL BUTT JOINT AND HMA TAPER FOR MILLING AND RESURFACING

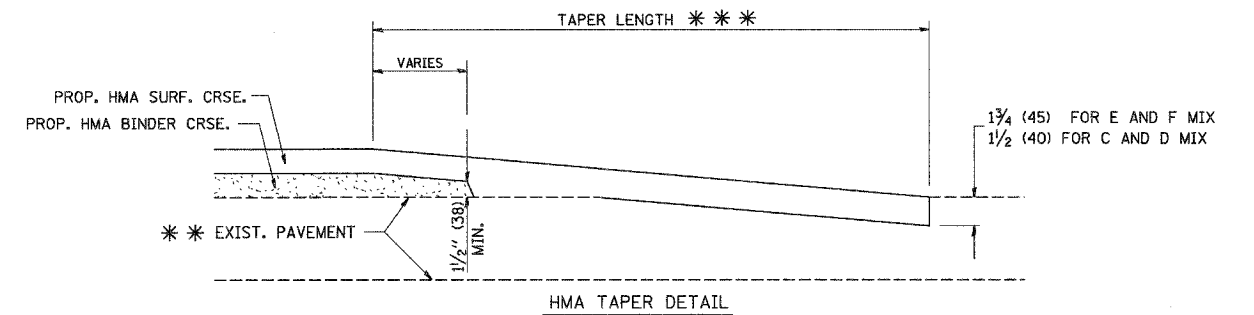
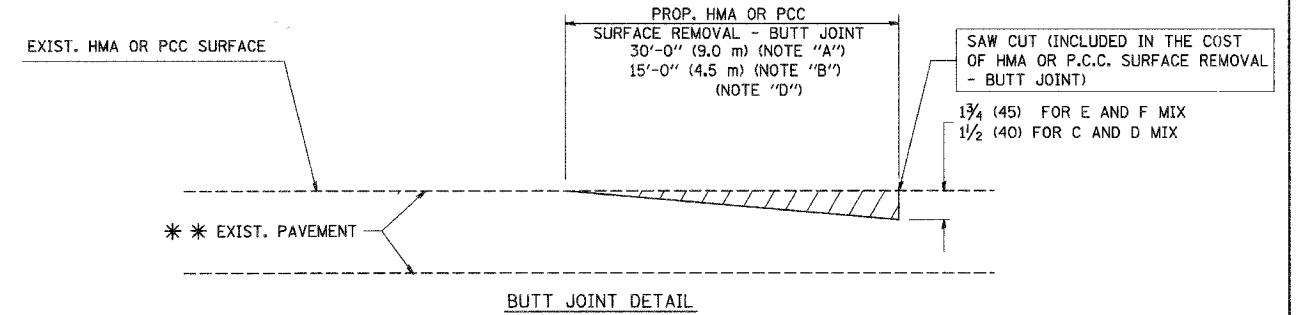

TYPICAL BUTT JOINT AND HMA TAPER FOR RESURFACING ONLY

\*\*\* PC CONCRETE, HMA OR HMA RESURFACED PAVEMENT.

NOTES

- A: MAINLINE ROADWAYS AND MAJOR SIDE ROADS.
- B: MINOR SIDE ROADS.
- C: THE TEMP. RAMP SHALL BE CONSTRUCTED IMMEDIATELY UPON REMOVAL OF THE EXISTING HMA SURFACE.
- D: THE BUTT JOINT SHALL BE CONSTRUCTED IMMEDIATELY PRIOR TO PLACING THE PROPOSED HMA COURSES.
- E: TAPER THE TEMP. RAMP AT A RATE OF 3'-0" (900 mm) PER 1 INCH (25 mm) OF MILLING THICKNESS.
- F: INSTALLATION AND REMOVAL OF THE 4'-6" (1.35 m) TEMP. RAMP IS INCLUDED IN COST OF HMA SURFACE REMOVAL - BUTT JOINT
- G: SEE ARTICLE 406.08 AND 406.14 OF THE STANDARD SPECIFICATIONS FOR "HMA AND/OR PCC SURFACE REMOVAL, BUTT JOINT".

\* SEE TYPICAL SECTIONS FOR MILLING THICKNESS.

\*\*\* 20'-0" (6.1 m) PER 1 (25) RESURFACING (NOTE "A")  
10'-0" (3.0 m) PER 1 (25) RESURFACING (NOTE "B")

ALL DIMENSIONS ARE IN INCHES (MILLIMETERS) UNLESS OTHERWISE SHOWN.

BASIS OF PAYMENT:

THE BUTT JOINT WILL BE PAID FOR AT THE CONTRACT UNIT PRICE PER SQUARE YARD (SQUARE METER) FOR "HOT-MIX ASPHALT SURFACE REMOVAL - BUTT JOINT" OR FOR "PORTLAND CEMENT CONCRETE SURFACE REMOVAL - BUTT JOINT".

REVISIONS	
NAME	DATE
M. DE YONG	6-13-90
M. DE YONG	7-3-90
M. DE YONG	3-27-92
R. SHAH	09/09/94
R. SHAH	10/25/94
A. ABBAS	03/21/97
M. GOMEZ	04/06/01
R. BORO	01/01/07

ILLINOIS DEPARTMENT OF TRANSPORTATION

BUTT JOINT AND HMA TAPER DETAILS

SCALE: VERT. NONE  
HORIZ.

DRAWN BY

CHECKED BY

BD400-05 (VI=BD32)