

F.A.U. RTE.	SECTION	COUNTY	TOTAL SHEETS	SHEET NO.
2508	02-00039-00-PV	KENDALL	146	107
STA.	TO STA.			
FED. ROAD DIST. NO.	ILLINOIS	FED. AID PROJECT		

S-07

87333

PLAN	DATE
BY	
REVISIONS	
NO.	

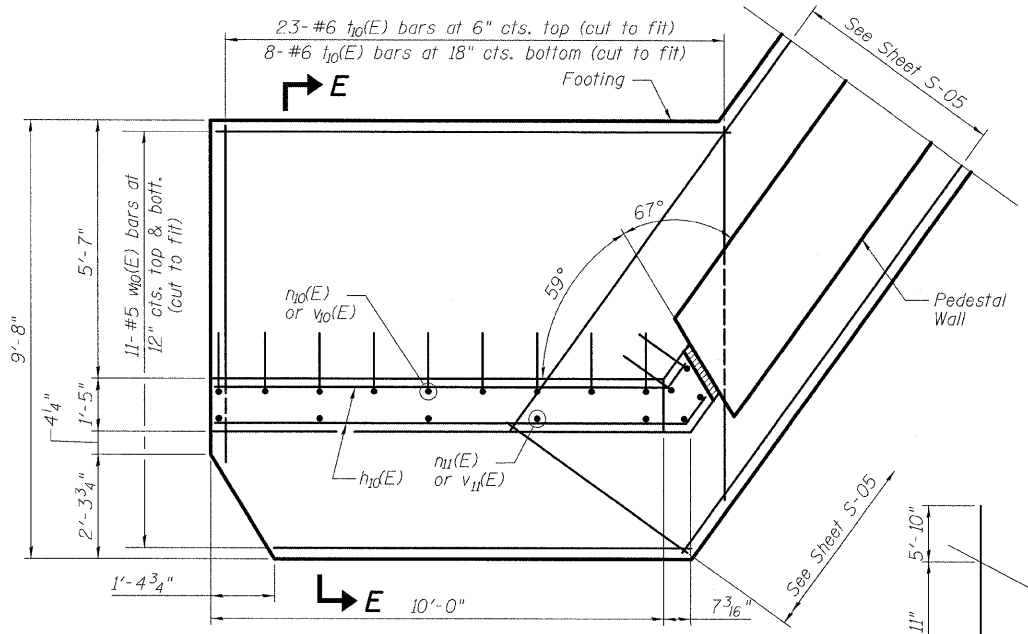

SECTION C-C

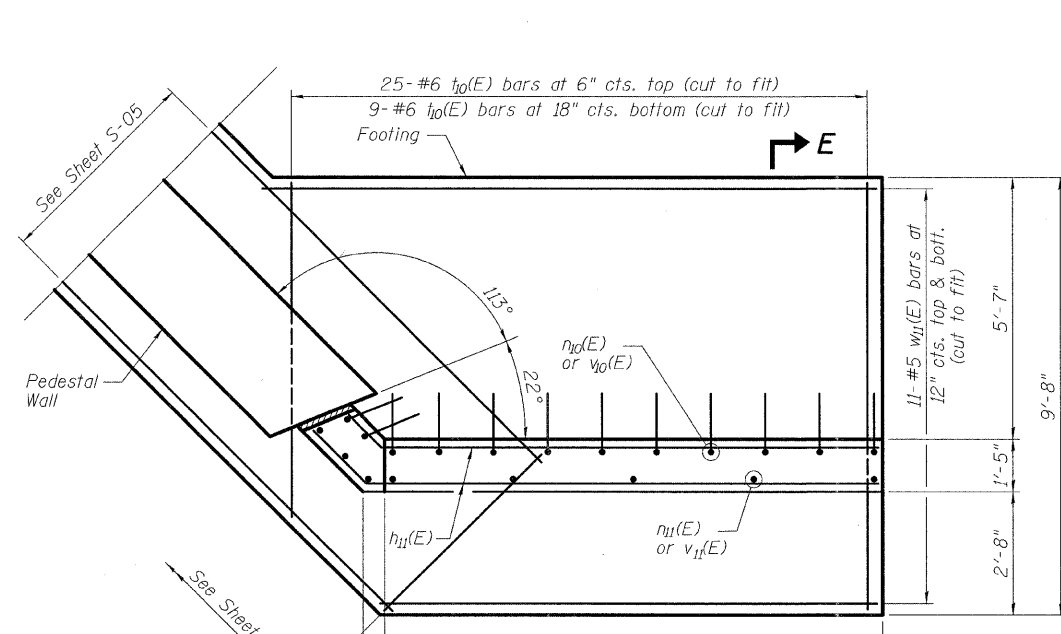

SECTION D-D

FIELD CUTTING DIAGRAM

Order  $v_{10}(E)$  &  $v_{11}(E)$  full length for S.E. wing wall. Cut as shown and use remainder in N.E. wing wall. Cut off excess length for N.W. wing wall in the field.

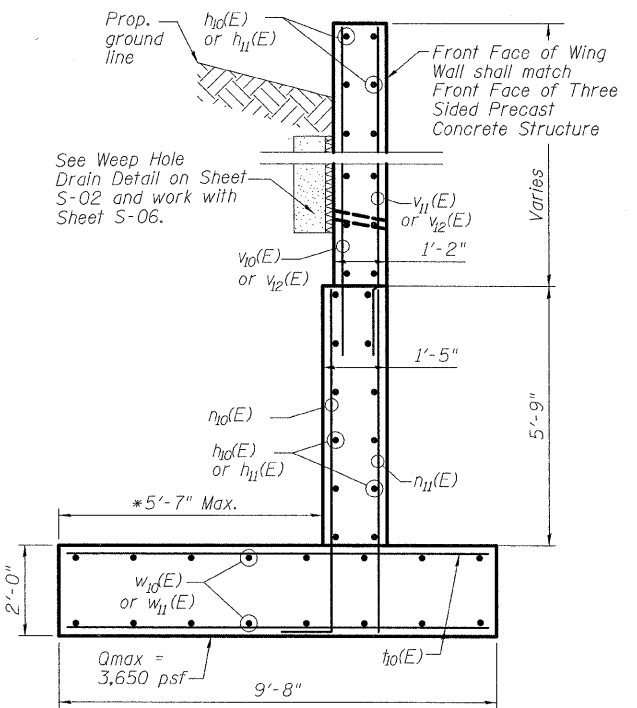

SECTION E-E

\* To be verified after Three Sided Precast Concrete Structure is installed.

PROF. ILE	DATE
BY	
REVISIONS	
NO.	

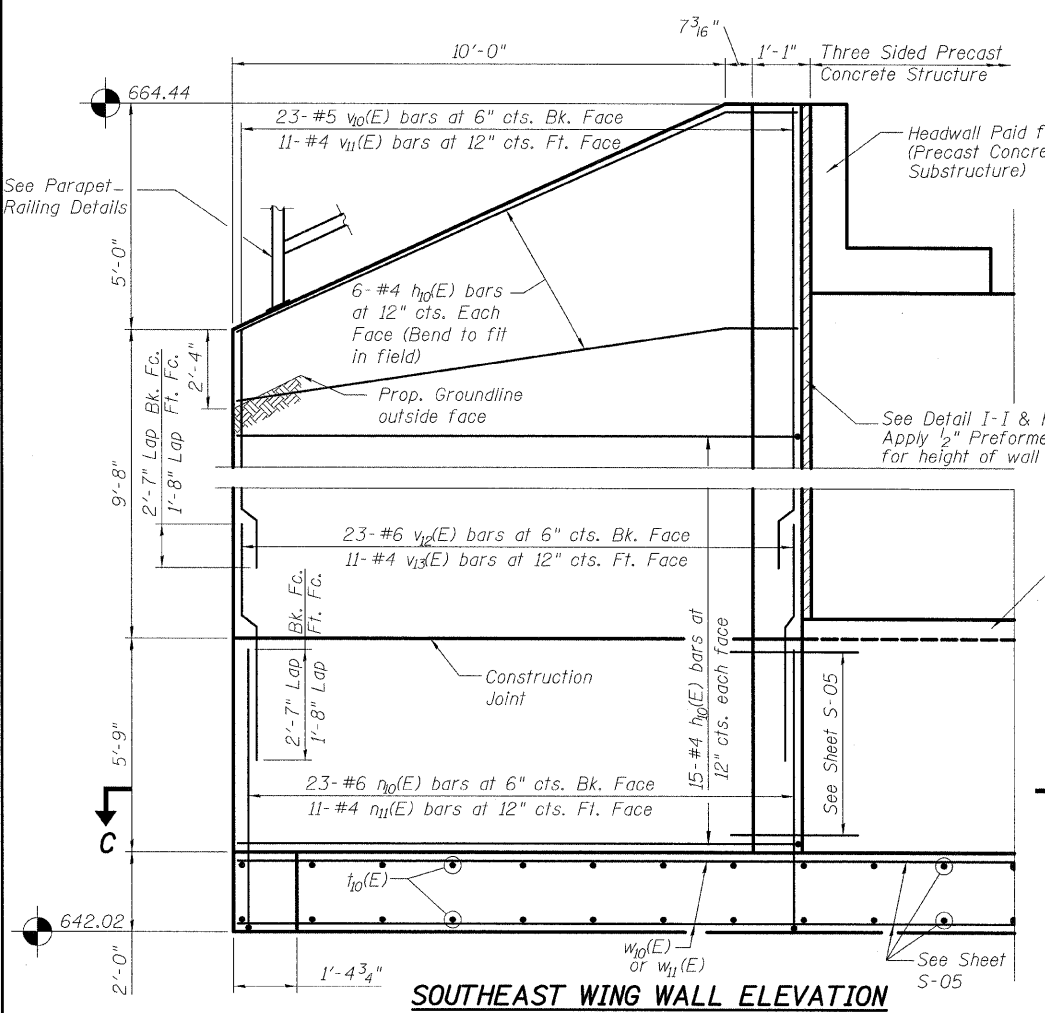

SOUTHEAST WING WALL ELEVATION

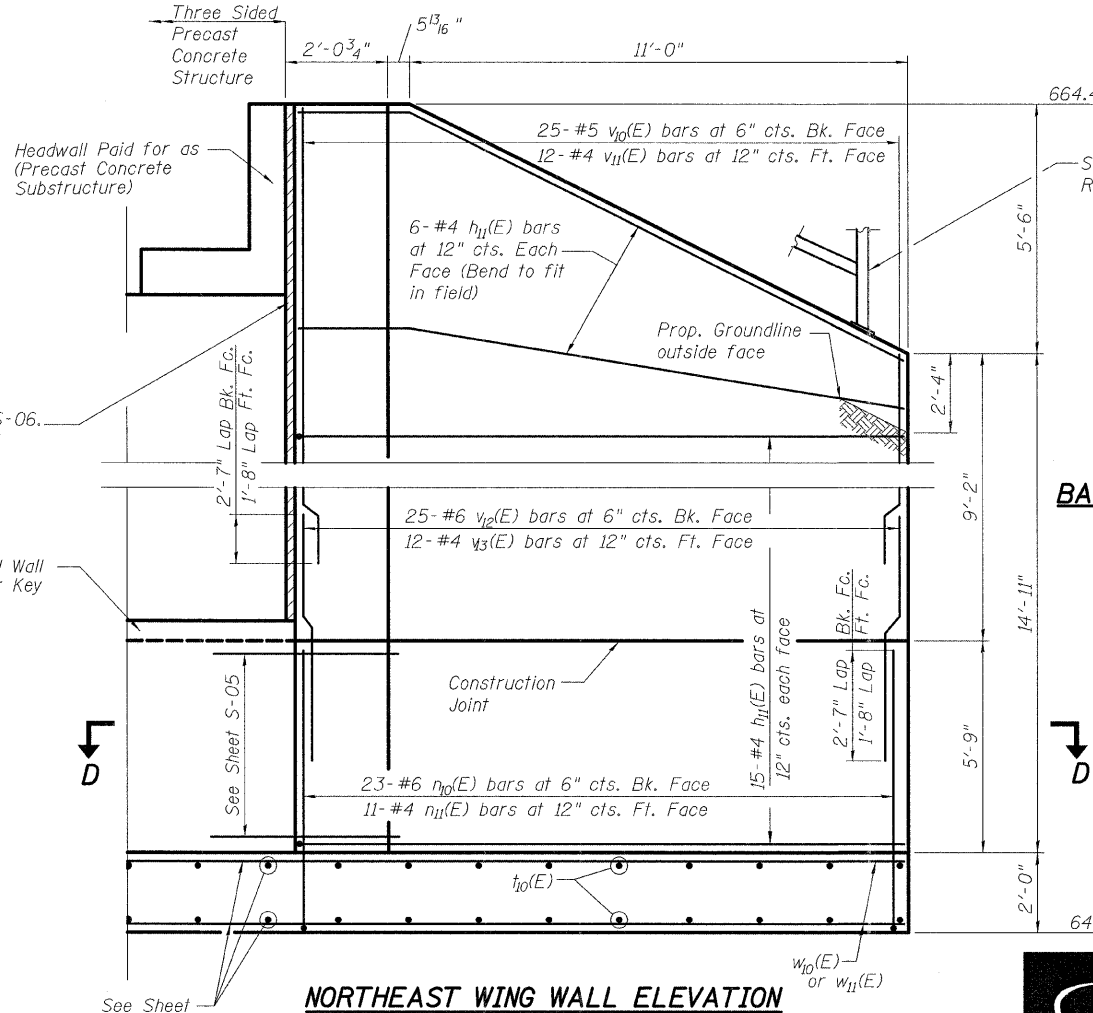

NORTHEAST WING WALL ELEVATION

BARS  $n_0(E)$  &  $n_1(E)$

BILL OF MATERIAL  
N.E. & S.E. WING WALLS

Bar	No.	Size	Length	Shape
$h_{10}(E)$	42	#4	12'-6"	
$h_{11}(E)$	42	#4	14'-6"	
$n_{10}(E)$	46	#6	8'-2"	
$n_{11}(E)$	22	#4	7'-4"	
$t_{10}(E)$	65	#6	9'-3"	
$w_{10}(E)$	22	#5	11'-4"	
$w_{11}(E)$	22	#5	12'-6"	
$v_{10}(E)$	48	#5	16'-9"	
$v_{11}(E)$	24	#4	16'-9"	
$v_{12}(E)$	48	#6	8'-10"	
$v_{13}(E)$	23	#4	7'-5"	
Reinforcement Bars, Epoxy Coated			Pound	4,330
Structure Excavation			Cu. Yd.	177
Concrete Structures			Cu. Yd.	27.9
Geocomposite Wall Drain			Sq. Yd.	14.2
Porous Granular Embankment (Special)			Cu. Yd.	11.25

NOTES:

- Bars indicated thus 1 x 2 - #5 etc. indicates 1 line of bars with 2 lengths per line.
- Work this sheet with sheet S-02, S-03 and S-05 to S-10.

**SEC GROUP, INC.**  
 Illinois Professional Design Firm # 184-000108  
 Smith Engineering Consultants • SEC Automation • SEC Planning  
 4500 Prime Pkwy, McHenry, IL 60050-2136  
 T. 815.385.1778 F. 815.385.1781  
 www.secgroupinc.com engineering@secgroupinc.com

ILLINOIS DEPARTMENT OF TRANSPORTATION  
**F.A.U. 2508 - DOUGLAS ROAD**  
**(U.S. RTE 34 TO U.S. RTE 30)**  
**WING WALL DETAILS**  
**DOUGLAS ROAD OVER WAUBONSEE CREEK**  
**SECTION 02-00039-00-PV, STA. 49+42**  
**SN 047-6306, KENDALL COUNTY**

SCALE: VERT. \_\_\_\_\_ DRAWN BY \_\_\_\_\_  
 HORIZ. \_\_\_\_\_ CHECKED BY \_\_\_\_\_  
 DATE \_\_\_\_\_