

F.A.S. RTE.	SECTION	COUNTY	TOTAL SHEETS	SHEET NO.
556	04-00119-03-BR	SANGAMON	26	14
STA.		TO STA.		
FED. ROAD DIST. NO. 5		ILLINOIS		FED. AID PROJECT

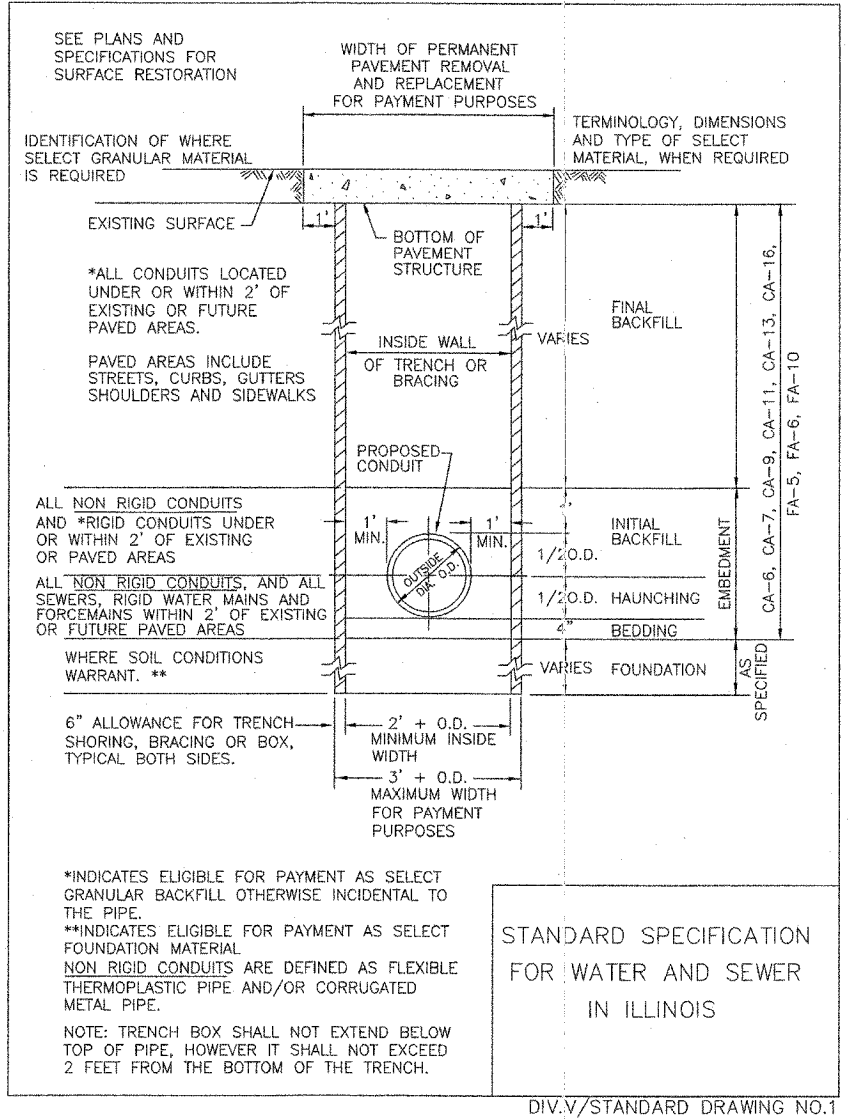
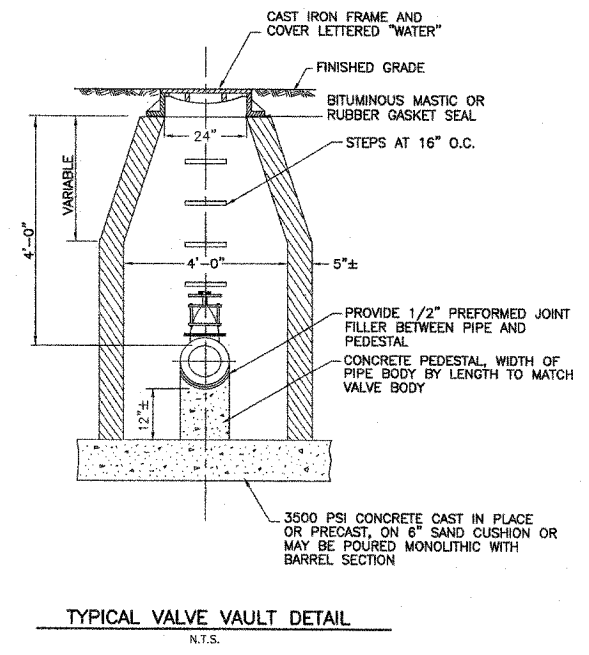
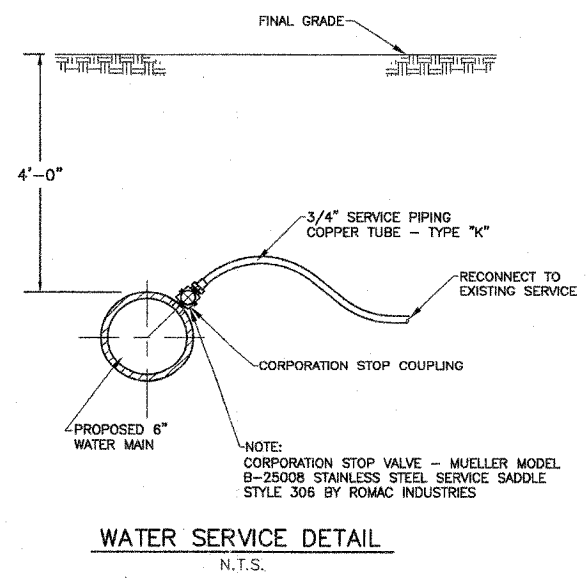
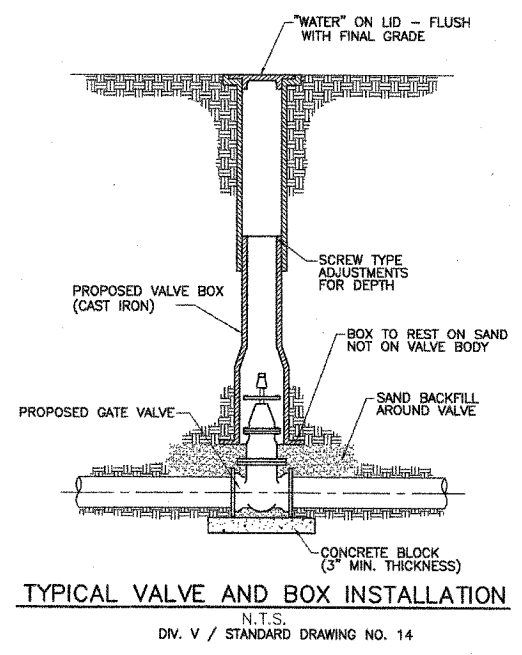

TABLE 1

INSIDE DIAMETER OF CONDUIT IN INCHES "D"	MAXIMUM TRENCH WIDTH IN FEET FOR PAYMENT	BEDDING C.Y./FOOT WHERE ELIGIBLE FOR PAYMENT	HAUNCHING C.Y./FOOT WHERE ELIGIBLE FOR PAYMENT	INITIAL BACKFILL C.Y./FOOT WHERE ELIGIBLE FOR PAYMENT	FINAL BACKFILL PER FOOT OF DEPTH WHERE ELIGIBLE FOR PAYMENT	PERMANENT PAVEMENT REMOVAL AND REPLACEMENT S.Y./FOOT
6	3.58	0.04	0.03	0.17	0.13	0.62
8	3.78	0.05	0.05	0.19	0.14	0.64
10	3.97	0.05	0.06	0.20	0.15	0.66
12	4.17	0.05	0.07	0.22	0.15	0.69
14	4.36	0.05	0.08	0.24	0.16	0.71
15	4.46	0.06	0.09	0.25	0.17	0.72
16	4.56	0.06	0.10	0.26	0.17	0.73
18	4.75	0.06	0.11	0.29	0.18	0.75
20	4.94	0.06	0.12	0.31	0.18	0.77
21	5.04	0.06	0.13	0.32	0.19	0.78
24	5.33	0.07	0.15	0.35	0.20	0.81
27	5.63	0.07	0.17	0.38	0.21	0.85
28	5.72	0.07	0.18	0.39	0.21	0.86
30	5.92	0.07	0.20	0.41	0.22	0.88
33	6.21	0.08	0.22	0.45	0.23	0.91
36	6.50	0.08	0.24	0.48	0.24	0.94
42	7.08	0.09	0.29	0.56	0.26	1.01
48	7.67	0.09	0.35	0.63	0.28	1.07
54	8.25	0.10	0.40	0.71	0.31	1.14
60	8.83	0.11	0.46	0.79	0.33	1.20
66	9.42	0.12	0.52	0.87	0.35	1.27
72	10.00	0.12	0.58	0.95	0.37	1.33
78	10.58	0.13	0.65	1.04	0.39	1.40
84	11.17	0.14	0.72	1.13	0.41	1.46
90	11.75	0.15	0.79	1.23	0.44	1.53
96	12.33	0.15	0.86	1.32	0.46	1.59
102	12.92	0.16	0.94	1.42	0.48	1.66
108	13.50	0.17	1.02	1.52	0.50	1.72
120	14.67	0.18	1.19	1.73	0.54	1.85

STANDARD DRAWING NO. 2

DIV.V/STANDARD DRAWING NO.2



REVISIONS

NUMBER	BY	DATE

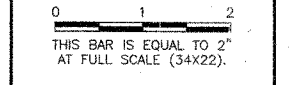

VILLAGE OF ROCHESTER
ROCHESTER, ILLINOIS

WATERMAIN & SANITARY SEWER REPLACEMENT
EAST MAIN STREET BRIDGE
TYPICAL DETAILS II

© Copyright CMT, Inc.

CMT
CRAWFORD, MURPHY & TILLY, INC.
CONSULTING ENGINEERS
License No. 194-000693

10/15/07
Expires 11/30/07

REGISTERED PROFESSIONAL ENGINEER & SURVEYOR
ILLINOIS STATE

DESIGN BY:	SJB
DRAWN BY:	RDM
CHECKED BY:	SJB
APPROVED BY:	[Signature]
DATE:	OCTOBER 15, 2007
JOB No:	07044-04-00

PATH: L:\SangamonCo\0402901\draw\sheet
FILE: C-DETALS-2.dwg
UPDATE BY: Rick Murphy
DATE: Monday, October 08, 2007 9:57:49 AM