**STRUCTURE GEOTECHNICAL REPORT
CULVERT REPLACEMENT AND RETAINING WALL
FAP 343/IL 68 OVER MFNB CHICAGO RIVER
SN 016-2842(PROPOSED CULVERT)
SN 016-2281(PROPOSED WALL), SECTION 30T-1
IDOT JOB D-91-185-10, PTB 154/13
COOK COUNTY, ILLINOIS**

For

**Bloom Companies, LLC.
600 W. Fulton Street, Suite 701
Chicago, IL 60661
(312) 876-9500**

Submitted by

**Wang Engineering, Inc.
1145 North Main Street
Lombard, IL 60148
(630) 953-9928**

**Original: November 3, 2014
Revised: September 29, 2015**

Technical Report Documentation Page

1. Title and Subtitle Structure Geotechnical Report, Culvert Replacement and Retaining Wall, Illinois Route 68 over Middle Fork North Branch (MFNB) Chicago River		2. Report Date September 29, 2015
		3. Report Type <input checked="" type="checkbox"/> SGR <input type="checkbox"/> RGR <input type="checkbox"/> Draft <input checked="" type="checkbox"/> Final <input checked="" type="checkbox"/> Revised
4. Route / Section / County FAP 0343/30T-1/ Cook		5. IDOT Job / Contract No. D-91-185-10
6. PTB / Item No. 154/13	5. Existing Structure Number(s) SN 016-0813 (Culvert)	6. Proposed Structure Number(s) SN 016-2842 (Culvert) SN 016-2281 (Retaining Wall)
7. Prepared by Wang Engineering, Inc. 1145 N Main Street Lombard, IL 60148	Contributor(s) Author: Andri Kurnia, P.E. QC/QA: Metin W. Seyhun, P.E. PIC: Corina T. Farez, P.E., P.G.	Contact Phone Number (630) 953-9928 ext. 1018 mseyhun@wangeng.com
9. Prepared for Bloom Companies, LLC. 600 W. Fulton Street Suite 701 Chicago, IL 60661	Design / Structural Engineer Thomas Zalewski, S.E., P.E.	Contact Phone Number (312) 876-9500 tzalewski@bloomcos.com
10. Abstract <p>The existing double-barrel 8'x11.5' culvert carrying Illinois 68 (Dundee Road) over the MFNB Chicago River at Lee Road will be removed and replaced by a new single cell 32'x6.5' CIP (cast-in-place) box culvert. This report provides geotechnical recommendations for the design and construction of the proposed box culvert and sheet pile wingwalls. Also, a new sheet pile retaining wall system along the southern end of IL 68 adjacent to the box culvert is proposed. There is a 60-inch storm sewer proposed near the wall's west end.</p> <p>The foundation soils consist of medium stiff to hard clay to silty clay loam, with occasional loose to medium dense granular soil layers, to the boring termination depths of 50 feet below ground surface (bgs). Bedrock was not encountered.</p> <p>The bearing capacity and settlement of the proposed box culvert is acceptable with some removal and replacement around Boring C-2 where silt was encountered. The wingwalls will be sheet pile wingwalls. The wingwalls will have a total height of approximately 13.5 feet with an exposed height of 9.0 feet. Global stability analyses show suitable factors of safety for the wingwalls.</p> <p>Geotechnical parameters to be used for the design of the sheet and soldier pile walls are provided in this report. Cofferdam and soil retention recommendations are also provided.</p>		
11. Path to archived file S:\Netprojects\2180102\Reports\RPT_Wang_MWS_02180102IL68overMFNBCulvertReplacementandRWV03_20150929.doc		

TABLE OF CONTENTS

1.0	INTRODUCTION	1
1.1	PROPOSED STRUCTURE	2
1.2	EXISTING STRUCTURE.....	2
2.0	SITE CONDITIONS AND GEOLOGICAL SETTING	2
2.1	PHYSIOGRAPHY	3
2.2	SURFICIAL COVER	3
2.3	BEDROCK	4
3.0	METHODS OF INVESTIGATION	4
3.1	SUBSURFACE INVESTIGATION	4
3.2	LABORATORY TESTING.....	5
4.0	RESULTS OF FIELD AND LABORATORY INVESTIGATIONS	5
4.1	SOIL CONDITIONS	5
4.2	GROUNDWATER CONDITIONS.....	6
4.3	SEISMIC DESIGN CONSIDERATIONS	6
5.0	FOUNDATION ANALYSIS AND RECOMMENDATIONS.....	6
5.1	CULVERT AND WINGWALLS.....	6
5.2	RETAINING WALL SN 016-2281.....	7
5.3	STAGE CONSTRUCTION CONSIDERATIONS	9
6.0	CONSTRUCTION CONSIDERATIONS	9
6.1	SITE PREPARATION	9
6.2	EXCAVATION, DEWATERING AND UTILITIES.....	10
6.3	FILLING AND BACKFILLING	11
6.4	EARTHWORK OPERATIONS.....	11
7.0	QUALIFICATIONS.....	12
	REFERENCES	13
	EXHIBITS	
	<i>1. Site Location Map</i>	
	<i>2. Site and Regional Geology</i>	

3. Boring Location Plan

4. Soil Profile

APPENDIX A

Boring Logs

APPENDIX B

Laboratory Test Results

APPENDIX C

Global Stability Analyses

APPENDIX D

Culvert TSL Plan

APPENDIX E

Retaining Wall TSL Plan

**STRUCTURE GEOTECHNICAL REPORT
CULVERT REPLACEMENT AND RETAINING WALL
FAP 343/IL 68 OVER MFNB CHICAGO RIVER
SN 016-2842 (PROPOSED CULVERT)/SN 016-2842 (PROPOSED WALL)
SECTION 30T-1
IDOT JOB D-91-185-10, PTB 154/13
COOK COUNTY, ILLINOIS
FOR
BLOOM COMPANIES, LLC**

1.0 INTRODUCTION

This report presents the results of our subsurface investigation, laboratory testing, and geotechnical evaluations for the proposed removal and replacement of the culvert carrying Illinois Route 68 (Dundee Road) over the Middle Fork North Branch (MFNB) Chicago River in Northbrook, Cook County, Illinois. The culvert extends from northwest to southeast direction under the intersection of IL 68 and Lee Road. A *Site Location Map* is presented as Exhibit 1.

Wang Engineering, Inc. (Wang) understands that the existing culvert was built in 1938 and is nearing its design life of 75 years. The structure does not meet hydraulic requirements for freeboard, and occasionally experiences debris accumulation particularly in the middle section which has resulted in occasional flooding/overtopping of Lee Road. Therefore, it was decided to totally replace the culvert. Based on information provided by Bloom, LLC (Bloom), Wang understands the design of this structure has been revised from a three sided structure to a CIP (cast-in-place) box culvert. On October 25, 2013 Wang submitted a Structure Geotechnical Report (SGR) for the three sided structure (Wang Project No. 218-01-01). The geotechnical information from the previous investigation is included in this report and was used to support our analyses and recommendations for the box culvert.

In addition, a new retaining wall (SN 016-2281) will be constructed along the south shoulder of IL 68 at the intersection with Lee Road. The wall will support the proposed 10-foot wide bike path. The report also provides recommendations for the retaining wall in Section 5.3.

The purpose of our investigation was to characterize site soil and groundwater conditions, perform geotechnical analyses, and provide recommendations for the design and construction of the proposed culvert, wingwalls, and retaining wall.

1.1 Proposed Structure

A TSL plan for the proposed box culvert replacing the initially designed three sided structure was provided by Bloom on August 31, 2015. Also, survey sections undertaken by Dynasty Group, Inc. along IL 68 and Lee Road were provided. The TSL plan is presented as Appendix D.

Wang understands the proposed structure (SN 016-2842) will be a single cell, 32-foot wide by 6.5-foot high CIP box culvert with sheet pile wingwalls. The structure length will measure 359.7 feet, and the out-to-out width will measure 34.0 feet (1-foot wall thickness) and intersects IL 68 at 19.1⁰. The existing roadway profile along IL 68 will have minor change. The top of pavement elevation at the structure will at about 646.0 feet. The culvert will have a downstream and upstream streambed elevation of 636.8 feet with the flow directed from northwest to southeast. The top of slab (invert) is located 0.5 feet below the streambed at 636.3 feet elevation. The culvert bottom slab elevation is 634.55 feet.

1.2 Existing Structure

The existing structure (SN 016-0813) is a double barrel, 8-foot by 11.5-foot concrete box culvert about 158 feet in length with invert elevation of 635.00 feet as per Hydraulic Report by Hey and Associates, Inc. (Hey 2012).

The culvert runs from northwest to southeast direction across the intersection of IL 68 with Lee Road. The culvert sharply bends at about 45 degree angle at the entrance and exit of the culvert.

2.0 SITE CONDITIONS AND GEOLOGICAL SETTING

The project area is located at the intersection of IL 68 (Dundee Road) and Lee Road, in northeastern Cook County's Village of Northbrook. The North Branch of the Chicago River flows from the northwest to the southeast directly beneath the above intersection. On the USGS *Highland Park 7.5 Minute Series* map, the project area overlaps in the NE¹/₄ of Section 10, SE¹/₄ of Section 3, SW ¹/₄ of Section 2 and the NW ¹/₄ of Section 11 Tier 42 N, Range 12 E of the Third Principal Meridian.

The following review of published geologic data, with emphasis on factors that might influence the design and construction of the proposed engineering works, is meant to place the project area within a geological framework and confirm the dependability and consistency of the present subsurface

investigation results. For the study of the regional geologic framework, Wang considered northeastern Illinois in general and Cook County in particular. Exhibit 2 illustrates the *Site and Regional Geology*.

2.1 Physiography

The investigated intersection lies between two, low relief, roughly parallel morainal ridges; the Blodgett Moraine to the east and the Deerfield Moraine to the west. The project area spans the channel and flood plain of the North Branch of the Chicago River which generally traces the margin of the moraines as it flows from the northwest to southeast. The North Branch roughly parallels the Skokie Lagoons, approximately one mile east of the site, until their confluence three miles to the southeast at Watersmeet Woods.

The natural ground surface at the site is approximately 645 feet North American Vertical Datum (NAVD); Ground surface elevations along IL 68 rise to 660 feet a quarter mile east and to 675 feet a quarter mile west of the intersection as the roadway climbs the proximal flanks of the respective moraines. The river channel is generally confined by steep banks. The channel bottom is approximately 7 to 10 feet lower (635 to 638 feet) than the surrounding land. The river's floodplain is wooded and extends approximately 300 feet to either side of the channel.

2.2 Surficial Cover

The project area was shaped by continental glaciers and their meltwater from the Wisconsin Episode, most recent glacial period. An arcuate series of end moraines and interspaced low-relief lake plains were formed as pulsating advances and retreats of an icesheet lobe, from over what is now Lake Michigan, emplaced approximately 150 feet of glacial drift unconformably over the bedrock (Barnhardt, M.L., 2011, Hansel and Johnson 1996, Kolata and Nimz 2010, Leetaru et al. 2004).

The glacial cover is made up predominately of diamicton attributed to the Wadsworth Formation of Wedron Group. The Wadsworth Formation consists of relatively homogenous, massive, gray till with clay to silty clay matrix, with dolomite and shale clasts and occasional lenses of sorted and stratified silt (Hansel and Johnson 1996). From a geotechnical viewpoint, the Wadsworth diamicton is characterized by low plasticity, medium to low moisture content, medium to very stiff consistency, poor permeability, and low compressibility (Bauer et al. 1991).

An up to 25 feet thick cap of silt, clay and sand often overly the diamicton. These sediments are identified as the Equality Formation and are found in areas where postglacial, glacial, and proglacial

lakes formed as water was impounded by moraines or filled low areas and depressions (Barnhardt, M.L., 2011).

Modern sediments of silt, clay, and sand within the present day channels and floodplain are identified as the Cahokia Formation. These sediments are derived from eroded loess and diamicton and are found in thicknesses of up to 20 feet.

2.3 Bedrock

In the project area, the glacial deposits unconformably rest over a 200-foot thick Silurian-age dolostone. The top of bedrock may be encountered at approximately 150 feet below ground surface (bgs). (Leetaru et al 2004).

Structurally, the site is located on the eastern flank of the Wisconsin Arch, and approximately four miles north of the Des Plaines Disturbance. No underground mines have been mapped in the area (Kolata and Nimz 2010).

Our subsurface investigation results fit into the local geologic context. The borings drilled in the project area revealed the native sediments consists of silty and clayey diamicton with infrequent silt lenses. None of the borings encountered the top of bedrock.

3.0 METHODS OF INVESTIGATION

The following sections outline the subsurface and laboratory investigations performed by Wang. All elevations in this report are in NAVD 1988.

3.1 Subsurface Investigation

The subsurface investigation along the box culvert was performed by Wang in May 2013. The investigation included three structure borings, designated as Borings C-1 through C-3. A structure boring for a nearby retaining wall, designated as RW-1, was also used to supplement the subsurface data for this investigation. The borings were drilled from top of existing roadway pavement from elevations of 645.2 to 644.9 feet to depths of 50 feet bgs. Northings and eastings, and elevations were acquired with a mapping-grade GPS unit; stations and offsets were obtained from drawings. The as-drilled boring locations are shown in the *Boring Logs* (Appendix A) and in the *Boring Location Plan* (Exhibit 3).

A truck-mounted drilling rig, equipped with hollow stem augers, was used to advance and maintain an open borehole. Soil sampling was performed according to AASHTO T 206, "*Penetration Test and Split Barrel Sampling of Soils.*" The soil was sampled at 2.5-foot intervals to the boring termination depths.

Field boring logs prepared and maintained by a Wang geologist, included lithological descriptions, visual-manual soil classifications (IDH textural classification), results of pocket penetrometer or Rimac unconfined compressive strength (Qu) testing on cohesive soils, and Standard Penetration Test (SPT) results recorded as blows per 6 inches of penetration.

Groundwater observations were made during and at completion of drilling operations. The borings were backfilled with soil cuttings and bentonite chips, and the surface was restored as close as possible to the original condition.

3.2 Laboratory Testing

Soil samples were tested in the laboratory for moisture content (AASHTO T-265). Atterberg limits (AASHTO T 89/T 90) and particle size (AASHTO T 88) analyses were also performed on selected samples. Field visual descriptions of the soil samples were verified in the laboratory and classified according to the IDH Soil Classification System. Laboratory test results are shown on the *Boring Logs* (Appendix A) and in the *Laboratory Test Results* (Appendix B).

The soil samples will be retained in our laboratory for 60 days following this report submittal. After that time, soil samples will be discarded unless a specific written request is received as to their disposition.

4.0 RESULTS OF FIELD AND LABORATORY INVESTIGATIONS

Detailed descriptions of the soil conditions encountered during the subsurface investigation are presented in the attached *Boring Logs* (Appendix A) and in the *Soil Profile* (Exhibit 4). Please note that strata contact lines represent approximate boundaries between soil types. The actual transition between soil types in the field may be gradual in horizontal and vertical directions.

4.1 Soil Conditions

Borings C-1 through C-3, and RW-1 were drilled from top of existing roadway pavement from

elevations ranging from 645.2 to 644.9 feet. The pavement structure consists of 3.0 to 9.0 inches of hot mix asphalt over 9.0 to 12.0 inches of Portland cement concrete over 6 to 8 inches of crushed of stone base course.

Below the pavement structure, the borings encountered medium stiff to hard, brown/black to gray clay to silty clay loam with trace gravel that extended to boring termination depth of 50.0 feet bgs corresponding to 595.2 to 594.9 feet elevations. This layer has unconfined compressive strength (Q_u) values ranging from 0.50 to 4.67 tsf with an average of 2.31 tsf, and moisture content values from 12 to 29% with an average of 19%. It should be noted that loose to medium dense granular soil layers of loam, silt and sand were encountered in Boring C-1 from 629.7 to 624.7 feet elevations (5-foot thick loam); in Boring C-2 from 636.9 to 631.9 feet elevations (5-foot thick silt) and from 631.9 to 629.4 feet elevations (2.5-foot thick sand); and in Boring C-3 from 641.9 to 639.4 feet elevations (2.5-foot thick sand) and from 603.4 to 597.9 feet elevations (5.5-foot thick loam). The granular soil has SPT (N)-values ranging from 6 to 17 blows/foot with an average of 12 blows/foot. Bedrock was not encountered.

4.2 Groundwater Conditions

Groundwater was encountered in Boring C-2 at approximately 13.5 feet bgs (631.4 feet elevation) during drilling and was measured at 20.0 feet bgs (624.9 feet elevation) at completion of drilling.

4.3 Seismic Design Considerations

Seismic information is not required for buried structures and not required for this retaining wall.

5.0 FOUNDATION ANALYSIS AND RECOMMENDATIONS

Geotechnical evaluations and recommendations for the box culvert, wingwalls, and retaining wall are included in the following sections.

5.1 Culvert and Wingwalls

Wang recommends the preferred wing wall type to be a sheet pile with a concrete cap. T-type or soldier pile and lagging are also feasible but require more construction such as a temporary sheet pile wall and cofferdams. The culvert TSL plan approved August 31, 2015 is shown in Appendix D.

Wang has performed bearing capacity, settlement, and global stability analyses for the culvert barrel

and wingwalls. Our analyses show that the culvert barrel can be supported on a shallow foundation system, and that the sheet pile wingwalls are globally stable.

The foundation soils below the culvert barrel will generally consist of very stiff silty clay or silty clay loam. However, it should be noted that in Boring C-2, there is a 5-foot thick silt layer underlain by saturated sand. If this layer is encountered during construction, the silt layer can become unstable, thus it is recommended to remove and replace the silt and sand layers by structural fill in order to have proper foundation bearing surface or lower the foundations to bear upon very stiff silty clay. Dewatering may be necessary to stabilize the excavation.

Our evaluations show the bearing capacity of the foundation soils or new structural fill to carry the box culvert at the proposed foundation bearing elevation of about 634.55 feet (11.5 feet below the proposed roadway) is satisfactory and is not a governing factor.

Sheet pile and culvert barrels should be designed based on a lateral earth pressure diagram determined according to IDOT *Culvert Manual* (IDOT, 2000). Alternatively, backfill parameters recommended in Table 4 can be used to estimate lateral pressures on the side of the barrels and wing walls.

The global stability of the wingwalls was analyzed based on the soil profile described in Section 4.1 and the TSL plan. The maximum wingwall height is approximately 13.5 feet with exposed height of approximately 9.0 feet.

The minimum required FOS for both short-term and long-term conditions is 1.5 (IDOT, 1999). Analyses were performed with Slide v6.0, and the results of slope stability evaluations are shown in Appendix C. We estimated undrained (short-term) and drained (long-term) FOS of 6.9 and 2.3, respectively (Appendix C-1 and C-2). These conditions meet the IDOT's minimum requirements for global stability but a separate analysis must be performed to determine the sheet pile embedment.

5.2 Retaining Wall SN 016-2281

The proposed sheet pile retaining wall alignment is located along eastbound IL 68 (Dundee Road) and starts around the intersection with Lee Road and extends to the proposed new box culvert. The wall will run along the existing culvert outlet channel which will only carry lower flows from storm sewers. Therefore, scour effects were not considered for the retaining wall evaluation.

The new sheet pile retaining wall will be located in front of the existing T-type reinforced concrete retaining wall and will retain the proposed 10-foot wide bike path embankment. Based on a TSL plan for the retaining wall provided by Bloom on October 10, 2014, Wang understands a sheet pile wall is considered as a wall type. A soldier pile section is also considered for the section supporting the 60-inch diameter concrete storm sewer at Station 20+46.13. The maximum exposed wall height will be about 9.4 feet. The TSL plan is presented as Appendix E.

Soil geotechnical parameters shown in Table 3 are recommended to be used for the design of the cantilever sheet and soldier pile walls. The parameters were determined based on the soil conditions encountered in Borings RW-1 and C-3. The design of the wall should ignore 3 feet of soil in front of the wall measured from the finished ground surface elevation in providing passive pressure due to excavation required for installation of concrete facing, drainage system, existing soft channel bottom, and frost-heave condition. In developing the design lateral pressure, the lateral pressure due to construction equipment surcharge load should be added to the lateral earth pressure. Drainage behind the wall and underdrain should be as per 2012 IDOT Bridge Manual (IDOT, 2012B). The water pressure should be added to the earth pressure if drainage is not provided. The simplified earth pressure distribution shown in 2012 AASHTO LRFD Design Specification (AASHTO, 2012) or other suitable earth pressure distributions should be used. Design considerations should include deflection control at the top of the wall.

Table 3: Geotechnical Parameters for Design of Sheet and Soldier Pile Walls

Layer Elevations/ Soil Description	Moist Unit Weight (pcf)	Shear Strength Properties			Estimated Lateral Soil Modulus Parameter, k (pci)	Estimated Soil Strain Parameter, ϵ_{50}
		Short Term		Long Term(1)		
		Cohesion Cu (psf)	Friction Angle, ϕ (Degree)	Friction Angle, ϕ' (Degree)		
644.9* to varies Granular Backfill	125	0	32	32	45	--
644.9* to 641.9 Silty Clay Loam	120	4000	0	30	1400	0.0045
641.9 to 639.4 Sand	110	0	30	30	20	--
639.4 to 634.4 Clay	120	1325	0	28	420	0.0075

Layer Elevations/ Soil Description	Moist Unit Weight (pcf)	Shear Strength Properties			Estimated Lateral Soil Modulus Parameter, k (pci)	Estimated Soil Strain Parameter, ϵ_{50}
		Short Term		Long Term(1)		
		Cohesion Cu (psf)	Friction Angle, ϕ (Degree)	Friction Angle, ϕ' (Degree)		
634.4 to 624.4 Clay to Silty Clay Loam	120	2235	0	30	780	0.0058
624.4 to 619.4 Silty Clay Loam	120	1270	0	30	380	0.008
619.4 to 616.9 Silty Clay Loam	120	2790	0	30	950	0.0052
616.9 to 613.4 Silty Clay Loam	120	3850	0	30	1400	0.0048
613.4 to 603.4 Silty Clay Loam	120	2580	0	30	900	0.0055
603.4 to 597.9 Loam	120	0	33	33	60	--
597.9 to 594.9** Silty Clay	120	1970	0	28	650	0.006

* Grade elevation at boring location.

** Boring termination depth.

(1) Based on Figure 3-4, USACE EM 1110-2-2504

5.3 Stage Construction Considerations

Wang understands that the preliminary construction phasing will involve detouring IL 68 where eastbound traffic will be detoured north on IL 43, east on Lake Cook Road and south on Skokie Boulevard returning to IL 68. Westbound traffic will take the reverse trip.

6.0 CONSTRUCTION CONSIDERATIONS

6.1 Site Preparation

Any unstable or unsuitable soils should be removed and replaced with compacted structural fill as described in Section 6.3. Precipitation run-off should be diverted away from excavations as part of the site preparation.

6.2 Excavation, Dewatering and Utilities

Excavations should be performed in accordance with local, state, and federal regulations. The excavation and backfill for the box culvert shall be according to Section 502 and any removal of the existing culvert shall be according to Section 501 of IDOT Standard Specifications for Bridge and Road Construction (IDOT 2012B).

Excavations for the construction of the box culvert should be sloped at no steeper than 1(V):1(H). The potential effect of ground movements upon nearby utilities should be considered during construction.

The Contractor shall submit a plan for diverting the channel water during construction. Based on the proposed culvert alignment, the existing culvert may be used as a diversion channel during construction with the necessary cofferdams as per Section 502.06 of the Standard Specifications (IDOT 2012B).

Cofferdams

Type 2 cofferdams* (without seal) will be required – two for the culvert (016-2842) and one for the sheet pile retaining wall (016-2281). Cofferdams for the culvert (016-2842) will be required - one at the Culvert inlet at its West end, and a second one along the southeast portion of the box. This second cofferdam will have one end point butt up against the permanent sheet pile wall (016-2281) just west of where the retaining wall meets the culvert; it will then run parallel along the culvert, make the turn around the East end of the culvert, and then terminate by butting up against the northeast sheet pile wingwall.

A cofferdam for the permanent sheet pile wall (016-2281) will be required to facilitate construction of the 60-inch diameter storm sewer near the wall's west end.

*Type 2 Cofferdams will be required based on the Estimated Water Surface Elevation (EWSE) of 641.93 feet resulting in more than six feet of water above the bottom of the aforementioned proposed concrete structures (in accordance with the 2012 IDOT Bridge Manual).

Soil Retention

Temporary sheet piling will be required for Stage I construction of the box culvert, along and parallel to the North side of the box.

6.3 Filling and Backfilling

Fill material to attain the final design elevations should be structural fill material. Coarse aggregate of IDOT gradation CA-6 or pre-approved, compacted, cohesive or granular soil conforming to IDOT Section 204 would be acceptable as structural fill (IDOT 2012B). The fill material should be free of organic matter and debris. Structural fill should be placed in lifts and compacted according to Section 205, *Embankment* (IDOT 2012B).

All backfill materials must be pre-approved by the site engineer. To backfill the box culvert sections and wingwalls, we recommend porous granular material, such as crushed stone or crushed gravel that conforms to the gradation requirements specified in the standard specifications Section 1004 (IDOT 2012). Backfill material should be placed and compacted in accordance with the Section 205, *Embankment* (IDOT 2012B) and the *Culvert Manual* (IDOT 2000). Estimated design parameters for granular structural backfill materials are presented in Table 4.

Table 4: Estimated Granular Backfill Parameters

Soil Description	Porous Granular Material Backfill
Unit Weight	125 pcf
Angle of Effective Internal Friction	32°
Active Earth Pressure Coefficient	0.31
Passive Earth Pressure Coefficient	3.26
At-Rest Earth Pressure Coefficient	0.5

6.4 Earthwork Operations

The required earthwork can be accomplished with conventional construction equipment. Moisture and traffic will cause deterioration of exposed soils. Precautions should be taken by the Contractor to prevent water erosion of the exposed soils. A compacted bed will minimize water runoff erosion.

Earth moving operations should be scheduled not to coincide with excessive cold or wet weather (early spring, late fall or winter). Any soil allowed to freeze or soften due to the standing water should be removed. Wet weather can cause problems with subgrade compaction.

It is recommended that an experienced geotechnical engineer be retained to inspect the exposed subgrade, monitor earthwork operations, and provide material inspection services during the construction phase of this project.

REFERENCES

- AMERICAN ASSOCIATION OF STATE HIGHWAY TRANSPORTATION OFFICIALS, 2012, *AASHTO LRFD Bridge Design Specifications*. United States Department of Transportation, Washington, D.C.
- BAUER, R.A., CURRY, B.B., GRAESE, A.M., VAIDEN, R.C., SU, W.J., and HASEK, M.J., 1991, Geotechnical Properties of Selected Pleistocene, Silurian, and Ordovician Deposits of Northeastern Illinois: Environmental Geology 139, Illinois State Geological Survey, 69 p.
- BARNHARDT, M.L., 2011, Surficial Geology of Highland Park Quadrangle, Lake and Cook Counties, Illinois: Illinois State Geological Survey, USGS-STATEMAP contract report, 2 sheets.
- DAY, R.W., 2006, *Foundation Engineering Handbook*, McGraw Hill.
- HANSEL, A.K., and JOHNSON, W.H., 1996, Wedron and Mason Groups: Lithostratigraphic Reclassification of the Wisconsin Episode, Lake Michigan Lobe Area: ISGS Bulletin 104: Champaign, Illinois State Geological Survey, 116 p.
- HEY and Associates, Inc., 2012, *Hydraulic Report - IL 68 (Dundee Road) at MFNB Chicago River and Shermer Road Bridge*.
- KOLATA, D.R. AND NIMZ, C.K., 2010, *Geology of Illinois*; University of Illinois, Urbana, ISGS, IL
- LEETARU, H.E., SARGENT, M.L., AND KOLATA, D.R., 2004, *Geologic Atlas of Cook County for Planning Purposes*, ISGS, Champaign, IL
- ILLINOIS DEPARTMENT OF TRANSPORTATION (1999) *Geotechnical Manual*. IDOT Bureau of Materials and Physical Research, Springfield, IL.
- ILLINOIS DEPARTMENT OF TRANSPORTATION (2000) *Culvert Manual*. IDOT Bureau of Bridges and Structures, Springfield, IL.
- ILLINOIS DEPARTMENT OF TRANSPORTATION (2012A) *Bridge Manual*. IDOT Bureau of Bridges and Structures, Springfield, IL.
- ILLINOIS DEPARTMENT OF TRANSPORTATION (2012B) *Standard Specifications for Road and Bridge Construction*. IDOT Division of Highways, Springfield, IL.
- NAVFAC, 1986, DM-7.02 *Foundations and Earth Structures*, Naval Facilities Engineering Command

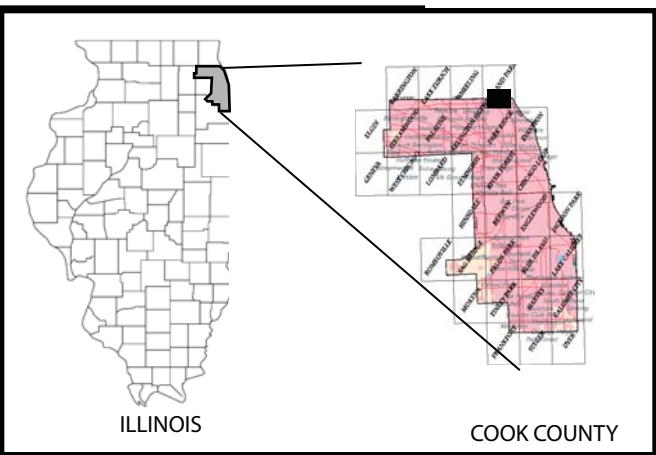
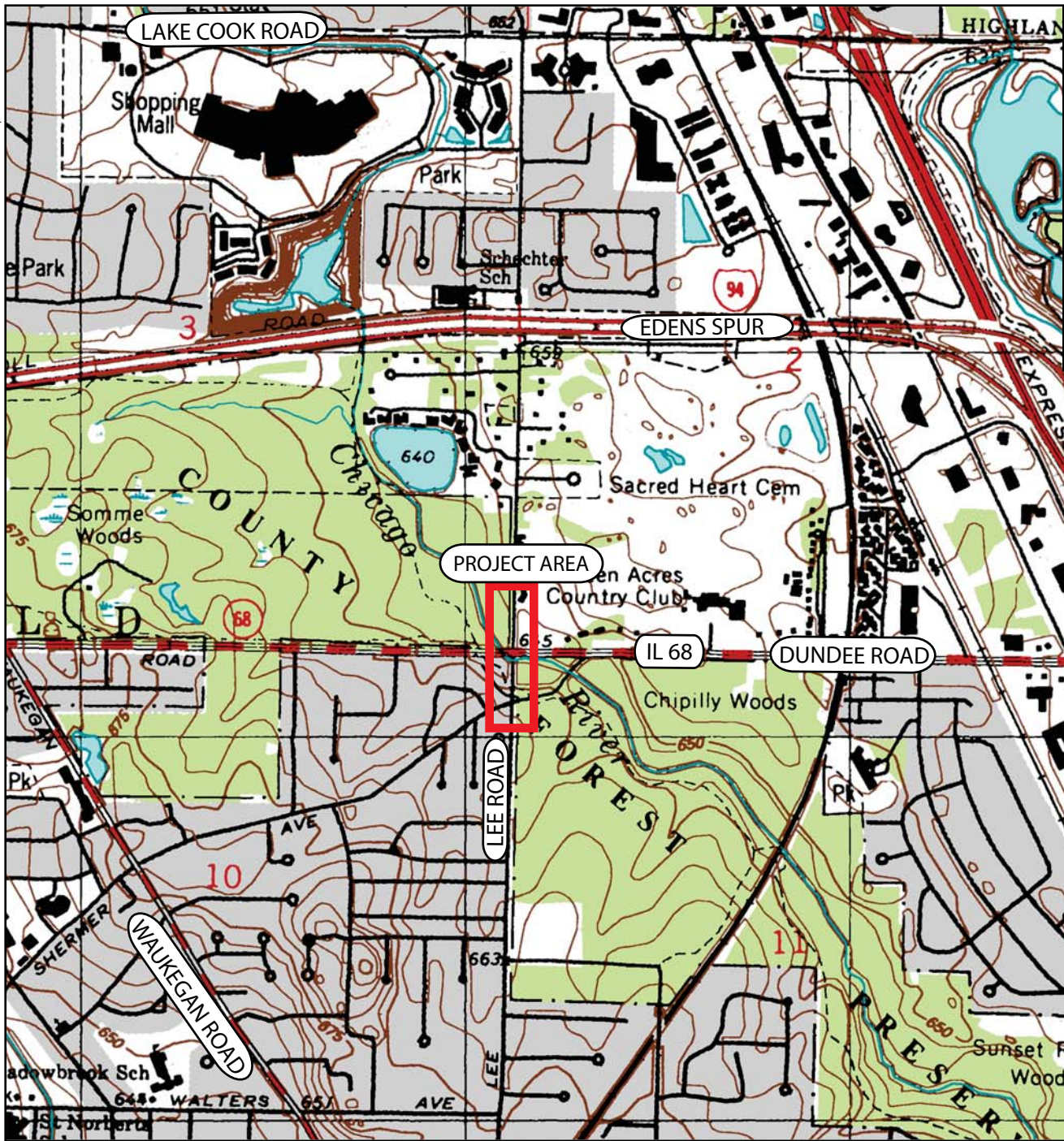

ILLINOIS

COOK COUNTY

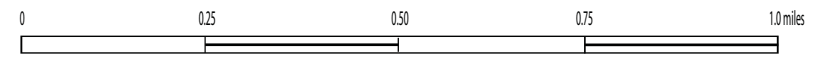

SITE LOCATION MAP: LEE ROAD IMPROVEMENTS, IL 68 OVER MFNB CHICAGO RIVER, PTB 154/ITEM 13, COOK COUNTY ILLINOIS,

SCALE: GRAPHICAL

EXHIBIT 1

DRAWN BY: E. DATZ
CHECKED BY: C. Marin



1145 N. Main Street
Lombard, IL 60148
www.wangeng.com

FOR BLOOM COMPANIES, LLC

218-01-01

EXHIBITS

LAKE COOK ROAD

03689

04293

03858

01393

EDENS SPUR

34674

340

IL 68

DUNDEE ROAD

PROJECT AREA

LEE ROAD

WAUKEGAN ROAD

03883

34835

34801

REGIONAL GEOLOGY

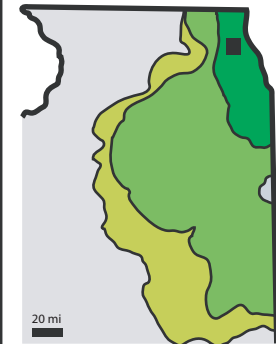

- LEGEND**
Wedron Group
- Wadsworth Formation
 - Lemont Formation
 - Tiskilwa Formation

Modified after Hansel and Johnson (1996)

LEGEND

- CAHOKIA FORMATION
Modern channel deposits; silt and clay
- EQUALITY FORMATION
Lacustrine deposits; silt, clay and sand
- WEDRON FORMATION
Diamicton; silty clay

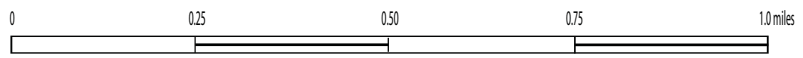

Modified after Barnhardt (2011)

SITE AND REGIONAL GEOLOGY: IL 68 OVER MFNB CHICAGO RIVER, PTB 154/ITEM 13 COOK COUNTY ILLINOIS,

SCALE: GRAPHICAL	EXHIBIT 2	DRAWN BY: E. DATZ CHECKED BY: C. Marin
------------------	-----------	---



1145 N. Main Street
Lombard, IL 60148
www.wangeng.com

FOR BLOOM COMPANIES, LLC	218-01-01
--------------------------	-----------

Benchmark:
Square cut in the top of the northwest corner of the headwall in the southeast quadrant of the intersection of Rte 68 and Lee Street. Elev. 646.61

Existing Structure:

S.N.016-0813, built in 1938. Existing Structure is a double 8'x11.5' reinforced concrete box culvert which is to be removed and replaced with a new concrete box structure. The east leg of IL 68 and the north leg Lee St. will be successively closed to traffic.

No Salvage

APPROVED

AUG 31 2015

AS A BASIS FOR PREPARATION OF DETAILED PLANS - IL 68

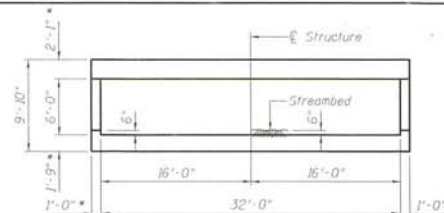
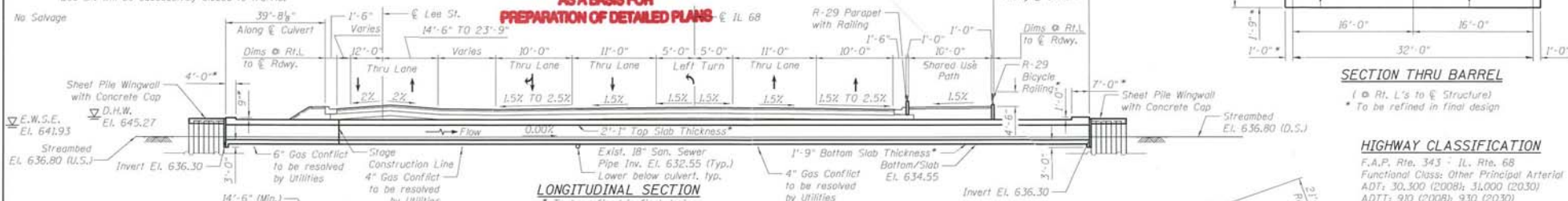

SECTION THRU BARREL

(E Rt. L's to E Structure)
To be refined in final design

HIGHWAY CLASSIFICATION

F.A.P. Rte. 343 - IL Rte. 68
Functional Class: Other Principal Arterial
ADT: 30,300 (2008); 31,000 (2030)
ADTT: 910 (2008); 930 (2030)
DHW: 3,190 (2030)
Design Speed: 50 m.p.h.
Posted Speed: 45 m.p.h.

Lee Street
Functional Class: Major Collector
ADT: 1,190 (2010)
ADTT: N/A
DHW: N/A
Design Speed: 30 m.p.h.
Posted Speed: 30 m.p.h.

DESIGN STRESSES

FIELD UNITS

f_c = 3,500 psi
f_y = 60,000 psi (Reinforcement)

LOADING HL-93

Allow 50 #/sq. ft. for future wearing surface

DESIGN SPECIFICATIONS

2014 AASHTO LRFD Bridge Design Specifications, 7th Edition

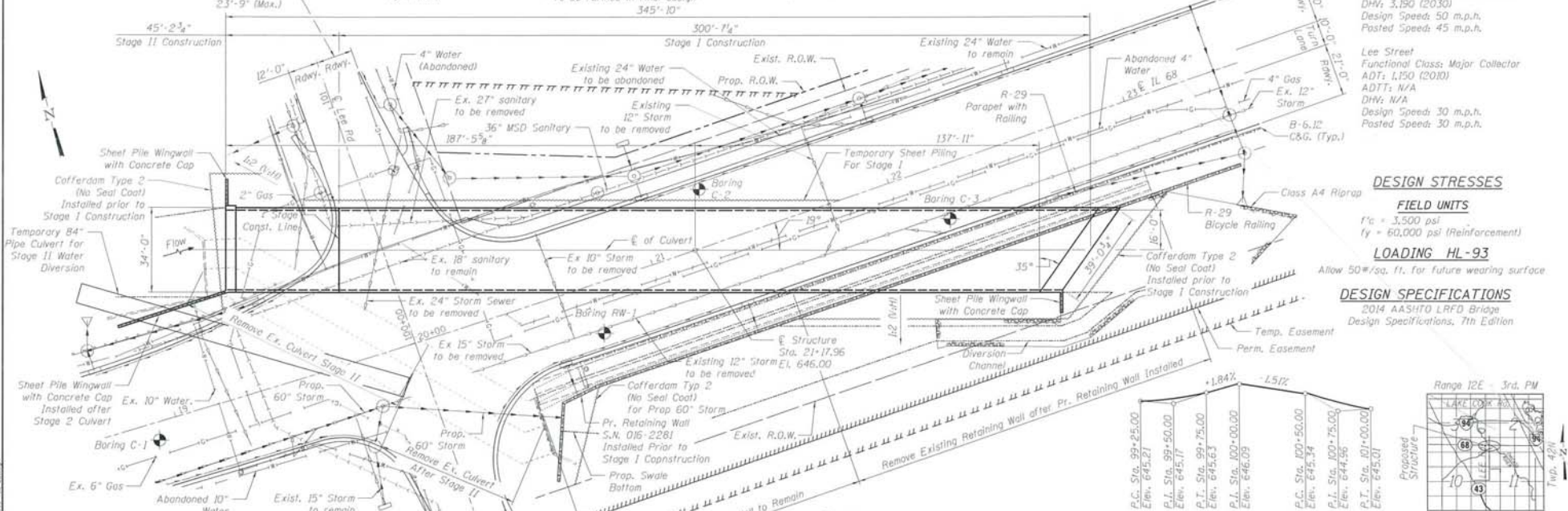

WATERWAY INFORMATION

Drainage Area = 13785.6 acres
215400 sq.mi.

Existing Overlapping Elev. 645.87 @ Sta. 20+50
Proposed Overlapping Elev. 645.98 @ Sta. 21+50

Flood	Freq. Yr.	Discharge C.F.S.	Opening Sq. Ft.	Not. H.W.E.	Created Head-(ft.)	Headwater Elev.
			Exist. Prop.	Exist. Prop.	Exist. Prop.	Exist. Prop.
Design (Overlapping)	10	449.00	157.1 176.0	644.51 644.51	0.13 0.06	644.64 644.57
Base	50	734.00	157.1 176.0	645.43 645.43	0.17 0.14	645.60 645.57
Max. Calc.	100	870.00	157.1 176.0	645.77 645.77	0.08 0.06	645.85 645.83
	500	1473.00	157.1 176.0	646.88 646.88	0.00 0.00	646.88 646.88

Note:
Waterway Information is preliminary and has not been approved. Subject to change.

BORING LOCATION PLAN: IL 68 OVER MFNB CHICAGO RIVER, PTB 154/ITEM 13, COOK COUNTY, ILLINOIS

SCALE: GRAPHIC EXHIBIT 3

Wang Engineering
1145 N. Main Street
Lombard, IL 60148
www.wangeng.com

FOR BLOOM COMPANIES, LLC. 218-01-02

PROFILE GRADE

(Along E Lee St.)
LVC = 50'

LOCATION SKETCH



GENERAL PLAN & ELEVATION
IL 68 (DUNDEE ROAD) OVER
MIDDLE FORK NORTH BRANCH CHICAGO RIVER
F.A.P. RTE. 343 - SEC 30T-1
COOK COUNTY
STATION 21+17.96
STRUCTURE NO. 016-2842

<p>BLOOM COMPANIES, LLC 1145 N. Main Street Lombard, IL 60148 www.bloomco.com</p>	USER NAME: PLOT SCALE: 1/8"=1'-0" PLOT DATE: 6/14/2015	DESIGNED - BCM/RS CHECKED - BT DRAWN - TVB CHECKED - 10/10/2014	REVISED REVISED REVISED REVISED	STATE OF ILLINOIS DEPARTMENT OF TRANSPORTATION	GENERAL PLAN & ELEVATION STRUCTURE NO. 016-2842 SHEET NO. 1 OF 2 SHEETS	<table border="1"> <tr> <th>F.A.P. RTE.</th> <th>SECTION</th> <th>COUNTY</th> <th>TOTAL SHEETS</th> </tr> <tr> <td>343</td> <td>30T-1</td> <td>COOK</td> <td>115 OF 117</td> </tr> </table> <p>CONTRACT NO. 60J13 ILLINOIS FED. AID PROJECT</p>	F.A.P. RTE.	SECTION	COUNTY	TOTAL SHEETS	343	30T-1	COOK	115 OF 117
	F.A.P. RTE.	SECTION	COUNTY	TOTAL SHEETS										
343	30T-1	COOK	115 OF 117											

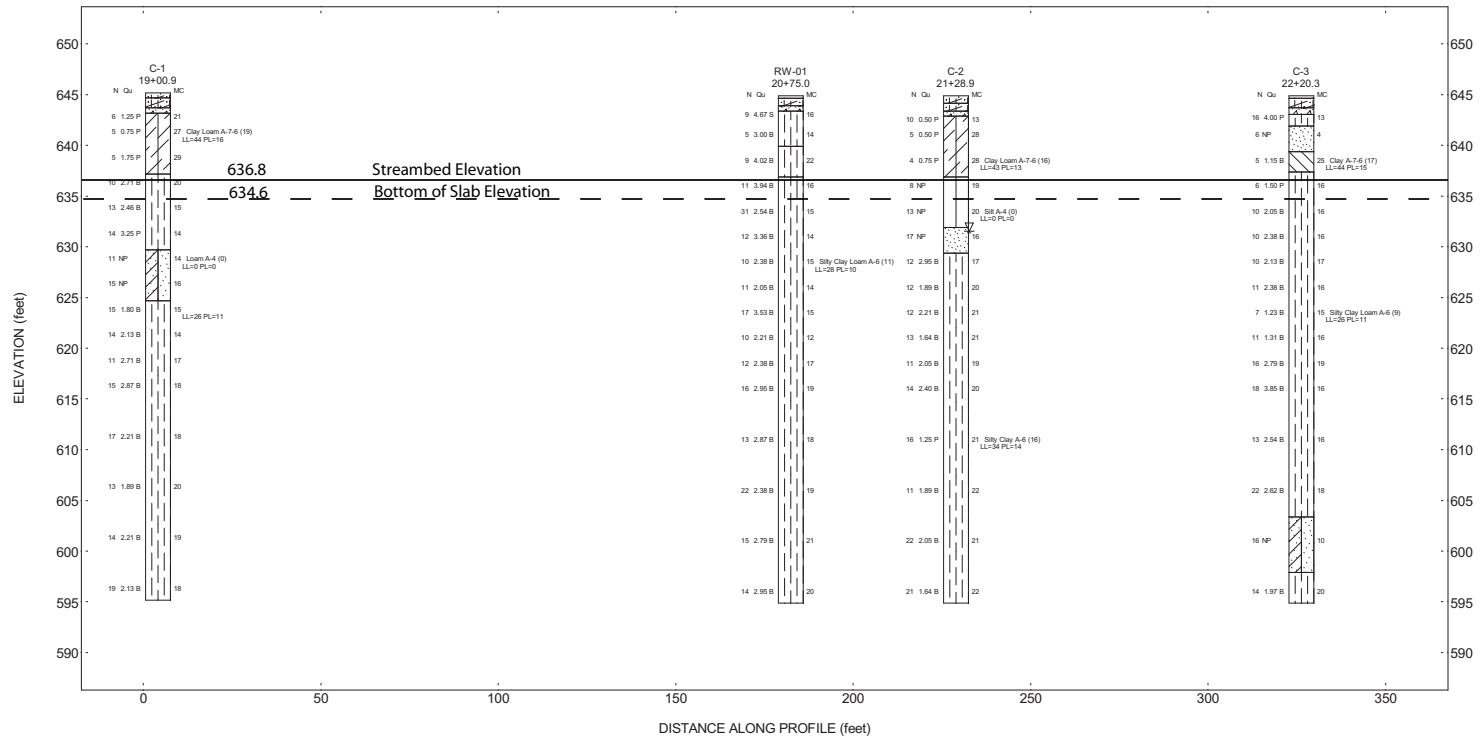

DISTANCE ALONG PROFILE (feet)

Lithology Graphics



Pavement



Crushed stone



IDH Clay Loam



IDH Silty Clay, Silty Clay Loam



IDH Loam

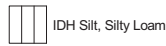

IDH Silt, Silty Loam

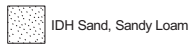

IDH Sand, Sandy Loam



IDH Clay

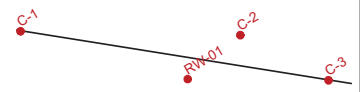

Site Map Scale 1 inch equals 130 feet

Explanation:

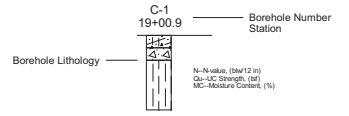

- Water Level Reading at time of drilling.
- Water Level Reading 24-hr after drilling or at end of drilling.

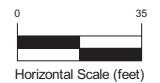

Vertical Exaggeration: 3x

Wang Engineering, Inc.
1145 N. Main Street
Lombard, IL 60148

Soil Profile



IL 68 over MFNB Chicago River
PTB 154/ ITEM 13, Cook County, IL

JOB NUMBER	PLATE NUMBER
218-01-01	EXHIBIT 4

APPENDIX A



wangeng@wangeng.com
 1145 N Main Street
 Lombard, IL 60148
 Telephone: 630 953-9928
 Fax: 630 953-9938

BORING LOG C-1

WEI Job No.: 218-01-01

Client **Bloom Companies, LLC**
 Project **IL 68 over MFNB Chicago River**
 Location **Northbrook, Cook County, IL**

Datum: NAVD 88
 Elevation: 645.20 ft
 North: 1993369.68 ft
 East: 1126269.99 ft
 Station: 19+00.9
 Offset: 22.3 LT

Profile	Elevation (ft)	SOIL AND ROCK DESCRIPTION	Depth (ft)	Sample Type recovery	Sample No.	SPT Values (blw/6 in)	Qu (tsf)	Moisture Content (%)	Profile	Elevation (ft)	SOIL AND ROCK DESCRIPTION	Depth (ft)	Sample Type recovery	Sample No.	SPT Values (blw/6 in)	Qu (tsf)	Moisture Content (%)
	644.76	6-inch thick ASPHALT --PAVEMENT--															
	643.71	12-inch thick CONCRETE --PAVEMENT--															
	643.2	6-inch thick CRUSHED STONE --BASE COURSE--															
	642.2	stiff, gray CLAY LOAM, trace gravel			1	3 3 3	1.25 P	21									
	640.2	--FILL--			2	2 2 3	0.75 P	27									
		Medium stiff, gray/black CLAY LOAM, trace gravel and roots --L _L (%)=44, P _L (%)=16-- --%Gravel=1.9-- --%Sand=25.0-- --%Silt=48.0-- --%Clay=25.0--			3	2 2 3	2.38 S	29									
		Very stiff, brown to gray SILTY CLAY, trace gravel, occasional silt/sand lenses			4	3 4 6	2.71 B	20									
					5	3 5 8	2.46 B	15									
					6	4 6 8	3.25 P	14									
	629.7	Medium dense, gray LOAM, trace gravel --%Gravel=7.6-- --%Sand=44.7-- --%Silt=44.8-- --%Clay=2.8--			7	5 5 6	NP	14									
					8	5 7 8	NP	16									
	624.7	Stiff to very stiff, gray SILTY CLAY, trace gravel			9	5 5 10	1.80 B	15									
					10	4 6 8	2.13 B	14									
										595.2							

Boring terminated at 50.00 ft

GENERAL NOTES

WATER LEVEL DATA

Begin Drilling **05-17-2013** Complete Drilling **05-17-2013**
 Drilling Contractor **WTS** Drill Rig **Mobil B-57**
 Driller **K & K** Logger **D. Kolpacki** Checked by **M. Seyhun**
 Drilling Method **3.25-inch IDA HSA, auto hammer, boring backfilled**
with bentonite chips and cuttings, and pavement patched

While Drilling **Dry**
 At Completion of Drilling **Dry**
 Time After Drilling **N/A hours**
 Depth to Water **N/A ft**

The stratification lines represent the approximate boundary between soil types; the actual transition may be gradual.



wangeng@wangeng.com
 1145 N Main Street
 Lombard, IL 60148
 Telephone: 630 953-9928
 Fax: 630 953-9938

BORING LOG C-2

WEI Job No.: 218-01-01

Client: **Bloom Companies, LLC**
 Project: **IL 68 over MFNB Chicago River**
 Location: **Northbrook, Cook County, IL**

Datum: NAVD 88
 Elevation: 644.90 ft
 North: 1993365.79 ft
 East: 1126497.06 ft
 Station: 21+28.9
 Offset: 24.6 LT

Profile	Elevation (ft)	SOIL AND ROCK DESCRIPTION	Depth (ft)	Sample Type recovery	Sample No.	SPT Values (blw/6 in)	Qu (tsf)	Moisture Content (%)	Profile	Elevation (ft)	SOIL AND ROCK DESCRIPTION	Depth (ft)	Sample Type recovery	Sample No.	SPT Values (blw/6 in)	Qu (tsf)	Moisture Content (%)
	644.2	9-inch thick ASPHALT --PAVEMENT--															
	643.4	9-inch thick CONCRETE --PAVEMENT--															
	642.9	6-inch thick CRUSHED STONE --BASE COURSE--															
	641.9	stiff, gray CLAY LOAM, trace gravel --FILL--	5		1	5 7 3	0.50 P	13									
		Medium stiff, black to gray CLAY LOAM, trace gravel and roots --L _L (%)=43, P _L (%)=13-- --%Gravel=1.2-- --%Sand=36.1-- --%Silt=33.5-- --%Clay=29.1--			2	2 2 3	0.50 P	28				30		12	4 6 8	2.40 B	20
	636.4	Loose to medium dense, gray SILT, trace gravel	10		4	2 3 5	NP	19						13	7 7 9	1.25 P	21
		--%Gravel=0-- --%Sand=4.4-- --%Silt=92.6-- --%Clay=3.1--			5	4 6 7	NP	20									
			15		6	5 8 9	NP	16				40		14	4 5 6	1.89 B	22
	628.9	Stiff to very stiff, gray SILTY CLAY, trace gravel			7	4 5 7	2.95 B	17									
			20		8	3 5 7	1.89 B	20				45		15	4 9 13	2.05 B	21
					9	3 5 7	2.21 B	21									
			25		10	4 6 7	1.64 B	21				50		16	7 11 10	1.64 B	22
										594.9							

Boring terminated at 50.00 ft

GENERAL NOTES

Begin Drilling **05-17-2013** Complete Drilling **05-17-2013**
 Drilling Contractor **WTS** Drill Rig **Mobil B-57**
 Driller **K & K** Logger **D. Kolpacki** Checked by **M. Seyhun**
 Drilling Method **3.25-inch IDA HSA, auto hammer, boring backfilled**
with bentonite chips and cuttings, and pavement patched

WATER LEVEL DATA

While Drilling **16.00 ft**
 At Completion of Drilling **20.00 ft**
 Time After Drilling **N/A hours**
 Depth to Water **N/A ft**

The stratification lines represent the approximate boundary between soil types; the actual transition may be gradual.

WANGENG 2180101.GPJ WANGENG.GDT 10/1/13



wangeng@wangeng.com
 1145 N Main Street
 Lombard, IL 60148
 Telephone: 630 953-9928
 Fax: 630 953-9938

BORING LOG C-3

WEI Job No.: 218-01-01

Client **Bloom Companies, LLC**
 Project **IL 68 over MFNB Chicago River**
 Location **Northbrook, Cook County, IL**

Datum: NAVD 88
 Elevation: 644.90 ft
 North: 1993319.17 ft
 East: 1126588.16 ft
 Station: 22+20.3
 Offset: 21.4 RT

Profile	Elevation (ft)	SOIL AND ROCK DESCRIPTION	Depth (ft)	Sample Type recovery	Sample No.	SPT Values (blw/6 in)	Qu (tsf)	Moisture Content (%)	Profile	Elevation (ft)	SOIL AND ROCK DESCRIPTION	Depth (ft)	Sample Type recovery	Sample No.	SPT Values (blw/6 in)	Qu (tsf)	Moisture Content (%)
	644.73	3-inch thick ASPHALT --PAVEMENT--															
	643.7																
	643.1	11-inch thick CONCRETE --PAVEMENT--												11	5 7 9	2.79 B	19
	641.9	8-inch thick CRUSHED STONE --BASE COURSE--			1	4 8 8	4.00 P	13									
		Hard, gray and black SILTY CLAY LOAM, trace gravel and organics			2	3 3 3	NP	4				30		12	4 8 10	3.85 B	16
	639.4	--FILL--															
		Loose, brown SAND, little gravel			3	2 2 3	1.15 B	25									
		Stiff to very stiff, gray CLAY, trace gravel and organics, occasional silt/sand lenses --L _L (%)=44, P _L (%)=15-- --%Gravel=4.4-- --%Sand=27.9-- --%Silt=37.8-- --%Clay=29.9--			4	1 2 4	1.50 P	16				35		13	5 6 7	2.54 B	16
					5	3 4 6	2.05 B	16									
	631.9	Stiff to very stiff, gray SILTY CLAY LOAM, trace gravel			6	3 4 6	2.38 B	16				40		14	5 10 12	2.62 B	18
			15														
					7	3 4 6	2.13 B	17		603.4	Medium dense, gray LOAM, trace gravel						
					8	3 4 7	2.38 B	16				45		15	5 8 8	NP	10
			20														
		--L _L (%)=26, P _L (%)=11-- --%Gravel=5.3-- --%Sand=18.0-- --%Silt=53.7-- --%Clay=23.0--			9	2 2 5	1.23 B	15		597.9	Stiff, gray SILTY CLAY, trace gravel						
					10	3 4 7	1.31 B	16		594.9		50		16	5 6 8	1.97 B	20
			25														

WANGENG 2180101.GPJ WANGENG.GDT 10/1/13

GENERAL NOTES

WATER LEVEL DATA

Begin Drilling **05-16-2013** Complete Drilling **05-16-2013**
 Drilling Contractor **WTS** Drill Rig **Mobil B-57**
 Driller **K & K** Logger **D. Kolpacki** Checked by **M. Seyhun**
 Drilling Method **3.25-inch IDA HSA, auto hammer, boring backfilled**
with bentonite chips and cuttings, and pavement patched

While Drilling **Dry**
 At Completion of Drilling **Dry**
 Time After Drilling **N/A hours**
 Depth to Water **N/A ft**

The stratification lines represent the approximate boundary between soil types; the actual transition may be gradual.



wangeng@wangeng.com
 1145 N Main Street
 Lombard, IL 60148
 Telephone: 630 953-9928
 Fax: 630 953-9938

BORING LOG RW-01

WEI Job No.: 218-01-01

Client **Bloom Companies, LLC**
 Project **IL 68 over MFNB Chicago River**
 Location **Northbrook, Cook County, IL**

Datum: NAVD 88
 Elevation: 644.90 ft
 North: 1993320.31 ft
 East: 1126442.68 ft
 Station: 20+75.0
 Offset: 21.5 RT

Profile	Elevation (ft)	SOIL AND ROCK DESCRIPTION	Depth (ft)	Sample Type recovery	Sample No.	SPT Values (blw/6 in)	Qu (tsf)	Moisture Content (%)	Profile	Elevation (ft)	SOIL AND ROCK DESCRIPTION	Depth (ft)	Sample Type recovery	Sample No.	SPT Values (blw/6 in)	Qu (tsf)	Moisture Content (%)
	644.73	3-inch thick ASPHALT															
	643.9	--PAVEMENT--															
	643.49	9-inch thick CONCRETE															
		--PAVEMENT--															
		6-inch thick CRUSHED STONE			1	6 5 4	4.67 S	16						11	3 5 7	2.38 B	17
		--BASE COURSE--															
		Very stiff to hard, brown SILTY CLAY, trace gravel			2	3 3 2	3.00 B	14						12	4 6 10	2.95 B	19
	639.9	--L _L (%)=38, P _L (%)=14--															
		--%Gravel=12.2--															
		--%Sand=15.2--															
		--%Silt=46.0--															
		--%Clay=26.7--															
		--FILL--			3	3 4 5	4.02 B	22									
	636.9	Hard, brown and gray SILTY CLAY, trace gravel															
		Very stiff, gray SILTY CLAY LOAM, trace gravel, occasional sand/silt lenses			4	3 5 6	3.94 B	16						13	5 6 7	2.87 B	18
					5	3 2 10	2.54 B	15									
					6	3 5 7	3.36 B	14						14	7 9 13	2.38 B	19
		--L _L (%)=28, P _L (%)=10--															
		--%Gravel=7.2--															
		--%Sand=16.1--															
		--%Silt=52.1--															
		--%Clay=24.5--															
					7	3 5 5	2.38 B	15									
					8	3 5 6	2.05 B	14						15	5 6 9	2.79 B	21
					9	4 7 10	3.53 B	15									
					10	2 4 6	2.21 B	12						16	4 6 8	2.95 B	20
										594.9							

Boring terminated at 50.00 ft

GENERAL NOTES

WATER LEVEL DATA

Begin Drilling **05-16-2013** Complete Drilling **05-16-2013**
 Drilling Contractor **WTS** Drill Rig **Mobil B-57**
 Driller **K & K** Logger **D. Kolpacki** Checked by **M. Seyhun**
 Drilling Method **3.25-inch IDA HSA, auto hammer, boring backfilled**
with bentonite chips and cuttings, and pavement patched

While Drilling **Dry**
 At Completion of Drilling **Dry**
 Time After Drilling **N/A hours**
 Depth to Water **N/A ft**

The stratification lines represent the approximate boundary between soil types; the actual transition may be gradual.

WANGENG 2180101.GPJ WANGENG.GDT 10/1/13

APPENDIX B

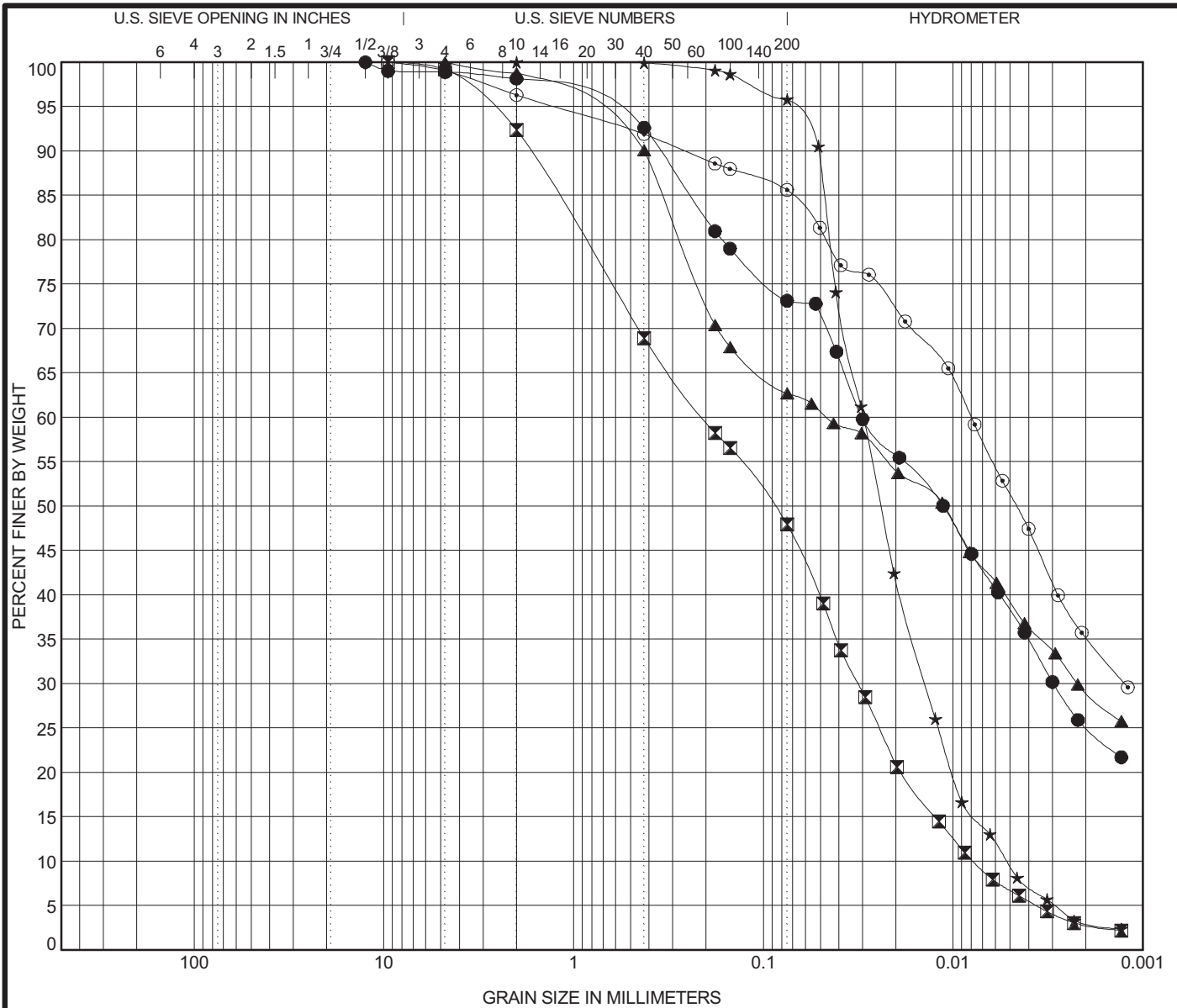

COBBLES	GRAVEL	SAND		SILT AND CLAY
		coarse	fine	

Specimen Identification		IDH Classification				LL	PL	PI	Cc	Cu
●	C-1#2 3.5 ft	Clay Loam				44	16	28		
☒	C-1#7 16.0 ft	Loam				NP	NP	NP	0.62	26.60
▲	C-2#3 6.0 ft	Clay Loam				43	13	30		
★	C-2#5 11.0 ft	Silt				NP	NP	NP	1.26	5.72
⊙	C-2#13 33.5 ft	Silty Clay				34	14	20		
Specimen Identification		D100	D60	D30	D10	%Gravel	%Sand	%Silt	%Clay	
●	C-1#2 3.5 ft	12.5	0.03	0.003		1.9	25.0	48.0	25.1	
☒	C-1#7 16.0 ft	9.5	0.207	0.032	0.008	7.6	44.7	44.8	2.8	
▲	C-2#3 6.0 ft	4.75	0.046	0.002		1.2	36.1	33.5	29.1	
★	C-2#5 11.0 ft	2	0.03	0.014	0.005	0.0	4.4	92.6	3.1	
⊙	C-2#13 33.5 ft	9.5	0.008	0.001		3.7	10.8	50.3	35.2	

WEI GRAIN SIZE IDH 2180101.GPJ US LAB.GDT 10/1/13



Wang Engineering, Inc.
 1145 N Main Street
 Lombard, IL 60148
 Telephone: 630 953-9928
 Fax: 630 953-9938

GRAIN SIZE DISTRIBUTION

Project: IL 68 over MFNB Chicago River
 Location: Northbrook, Cook County, IL
 Number: 218-01-01

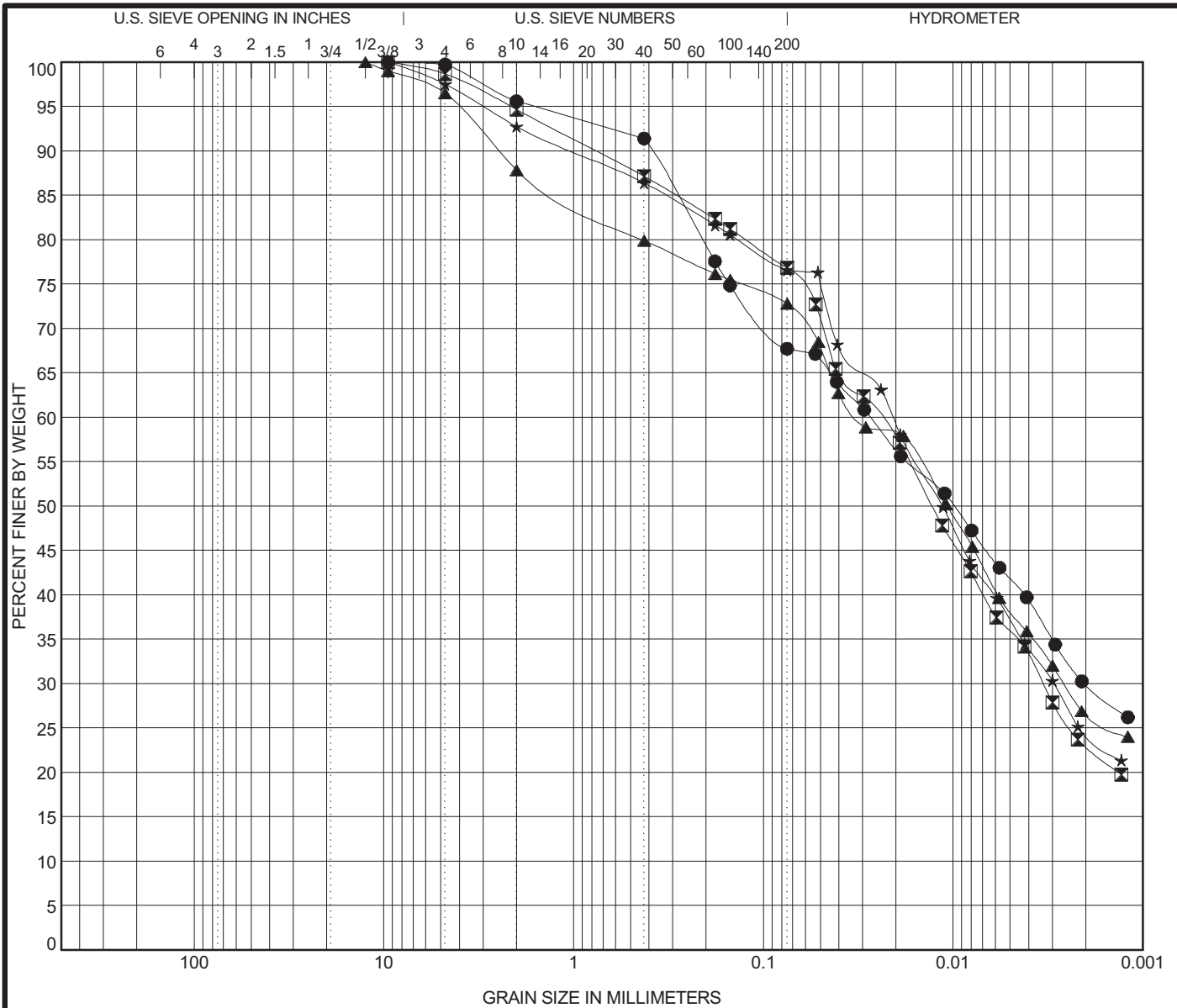

COBBLES	GRAVEL	SAND		SILT AND CLAY
		coarse	fine	

Specimen Identification	IDH Classification	LL	PL	PI	Cc	Cu
● C-3#3 6.0 ft	Clay	44	15	29		
■ C-3#9 21.0 ft	Silty Clay Loam	26	11	15		
▲ RW-01# 1.0 ft	Silty Clay	38	14	24		
★ RW-01#7 16.0 ft	Silty Clay Loam	28	10	18		

Specimen Identification	D100	D60	D30	D10	%Gravel	%Sand	%Silt	%Clay
● C-3#3 6.0 ft	9.5	0.027	0.002		4.4	27.9	37.8	29.9
■ C-3#9 21.0 ft	9.5	0.024	0.003		5.3	18.0	53.7	23.0
▲ RW-01# 1.0 ft	12.5	0.032	0.003		12.2	15.2	46.0	26.7
★ RW-01#7 16.0 ft	9.5	0.021	0.003		7.2	16.1	52.1	24.5



Wang Engineering, Inc.
 1145 N Main Street
 Lombard, IL 60148
 Telephone: 630 953-9928
 Fax: 630 953-9938

GRAIN SIZE DISTRIBUTION

Project: IL 68 over MFNB Chicago River
 Location: Northbrook, Cook County, IL
 Number: 218-01-01

WEI GRAIN SIZE IDH 2180101.GPJ US LAB.GDT 10/1/13

APPENDIX C

Slope Stability Analysis-Short Term (Boring C-3)

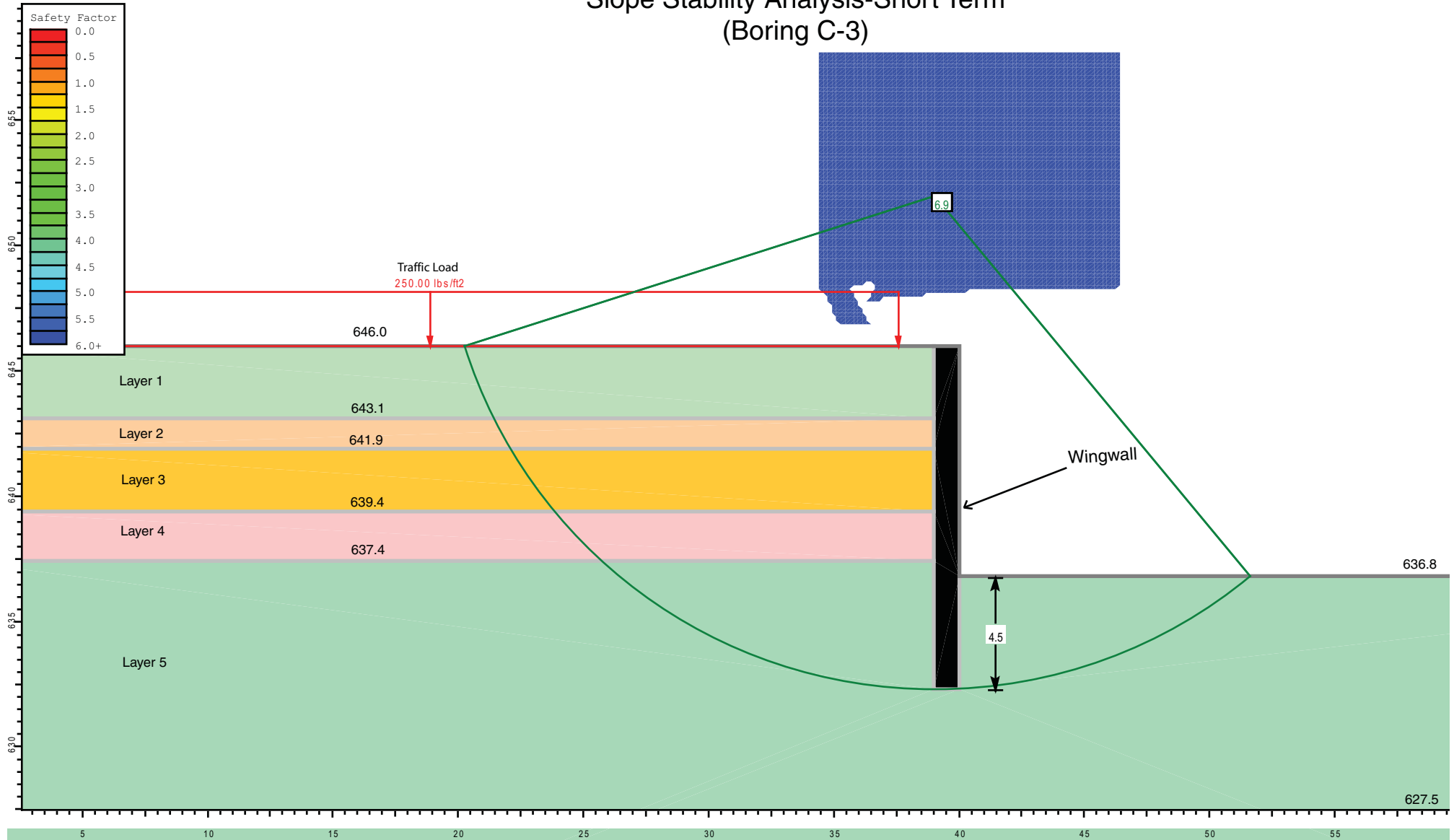

Soil Properties:

Layer ID	Soil Type	Unit Weight	Undrained Parameters	
		(pcf)	C (psf)	ϕ (deg.)
1	Cohesive FILL	125	1000	0
2	Hard SILTY CLAY LOAM	125	4000	0
3	Loose SAND	110	0	28
4	Stiff CLAY	120	1150	0
5	Stiff to Very Stiff SILTY CLAY LOAM	120	1900	0

SLOPE STABILITY ANALYSIS: IL 68 OVER MFNB CHICAGO RIVER, COOK COUNTY, IL

SCALE: GRAPHIC

APPENDIX C-1

DRAWN BY: H. Bista
CHECKED BY: A. Kurnia



1145 N. Main Street
Lombard, IL 60148
www.wangeng.com

BLOOM COMPANIES, LLC.

218-01-02

Slope Stability Analysis-Long Term (Boring C-3)

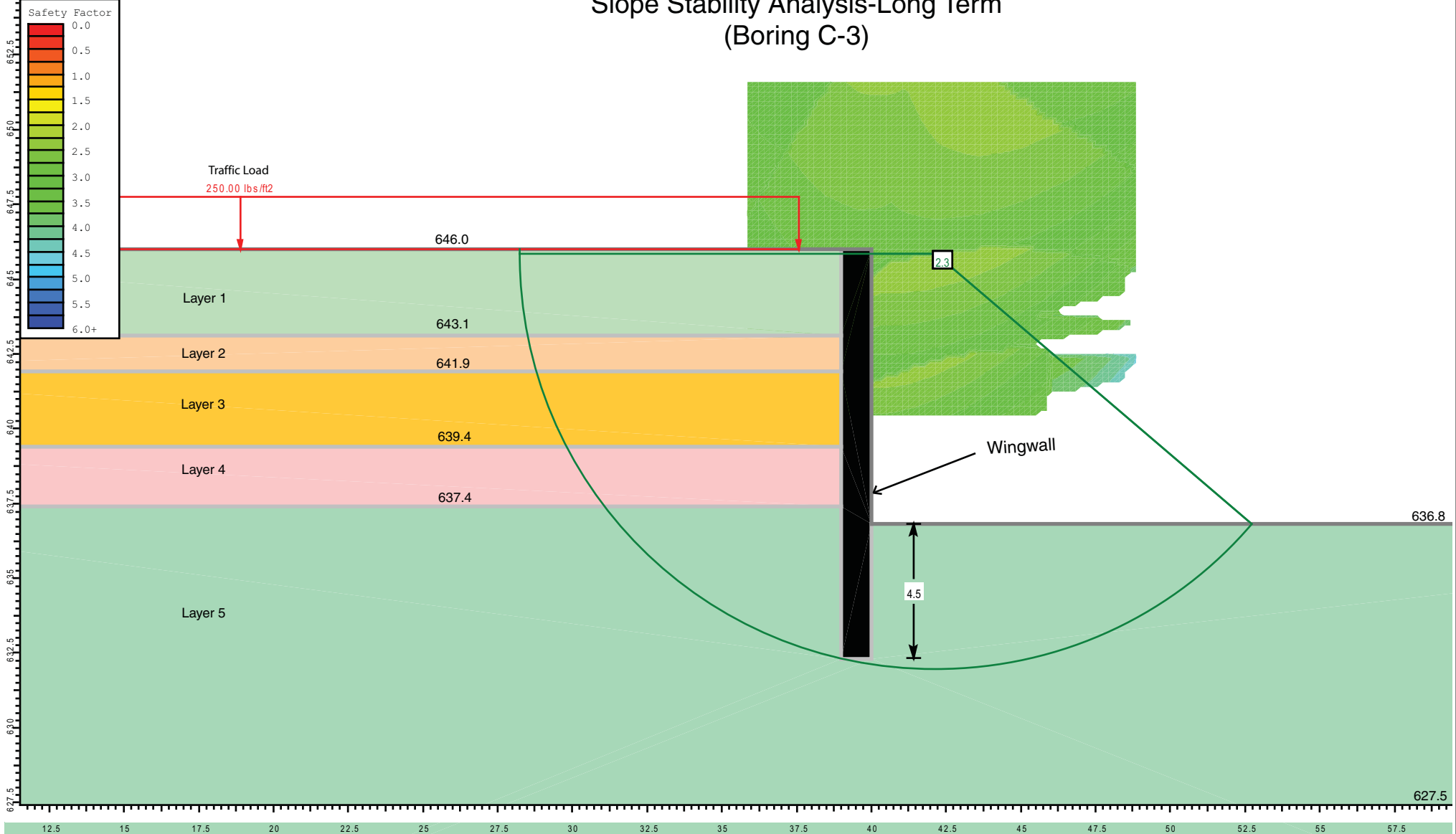

Soil Properties:

Layer ID	Soil Type	Unit Weight	Drained Parameters	
		(pcf)	C' (psf)	φ (deg.)
1	Cohesive FILL	125	100	29
2	Hard SILTY CLAY LOAM	125	100	30
3	Loose SAND	110	0	28
4	Stiff CLAY	120	100	29
5	Stiff to Very Stiff SILTY CLAY LOAM	120	100	31

SLOPE STABILITY ANALYSIS: IL 68 OVER MFNB CHICAGO RIVER, COOK COUNTY, IL

SCALE: GRAPHIC

APPENDIX C-2

DRAWN BY: H. Bista
CHECKED BY: A. Kurnia



1145 N. Main Street
Lombard, IL 60148
www.wangeng.com

BLOOM COMPANIES, LLC.

218-01-02

APPENDIX D

Benchmark: Square cut in the top of the northwest corner of the headwall in the southeast quadrant of the intersection of Rte 68 and Lee Street. Elev. 646.61

Existing Structure: S.N.016-0813, built in 1936. Existing Structure is a double 8'x11.5' reinforced concrete box culvert which is to be removed and replaced with a new concrete box structure. The east leg of IL 68 and the north leg Lee St. will be successively closed to traffic.

No Salvage

APPROVED

APPENDIX D

AUG 31 2015

AS A BASIS FOR PREPARATION OF DETAILED PLANS

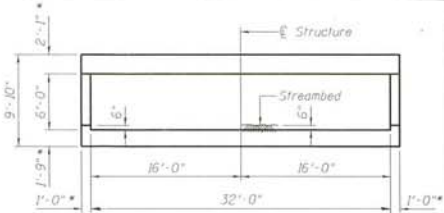
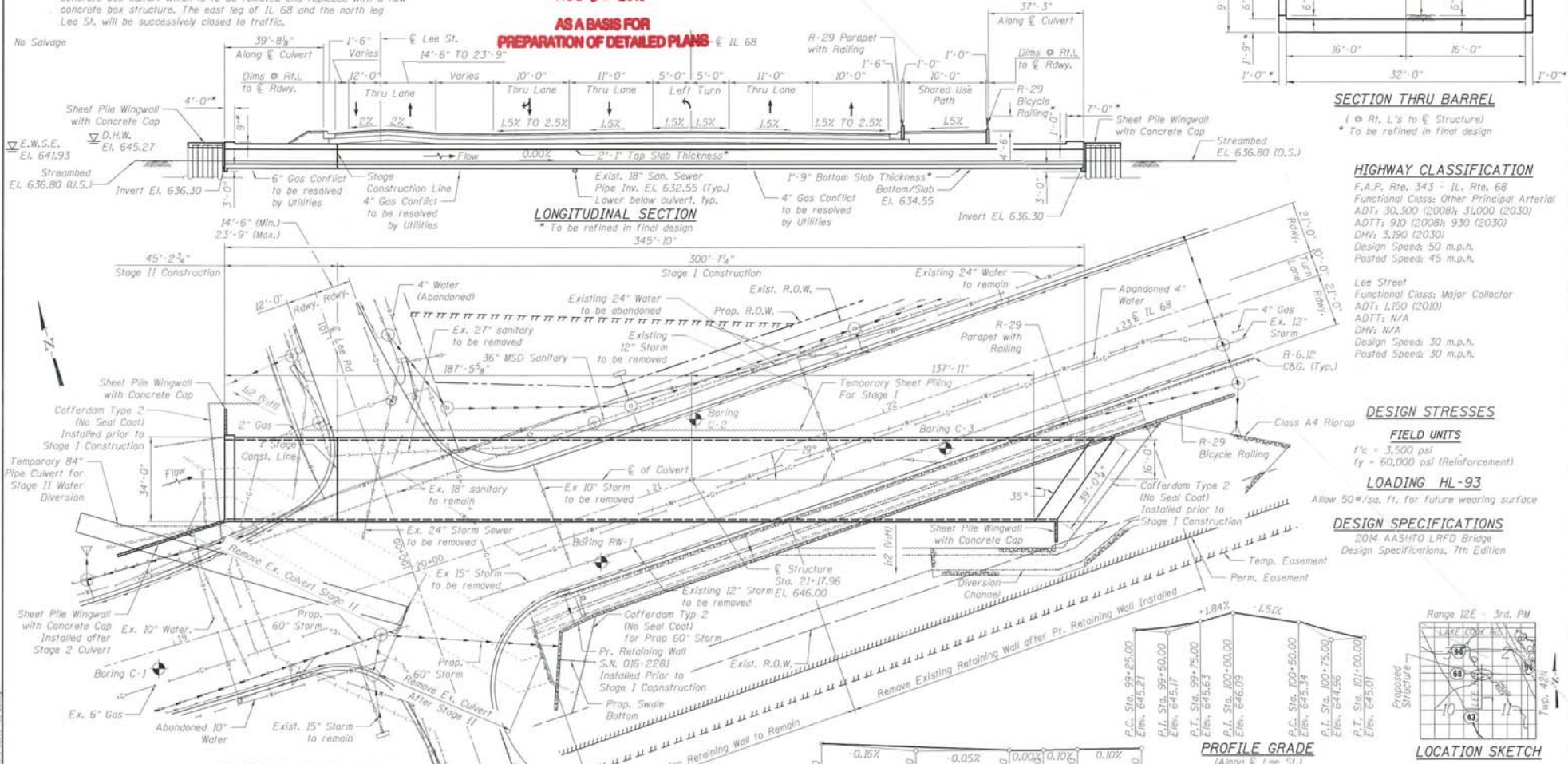

SECTION THRU BARREL

() R.L.'s to E. Structure
* To be refined in final design

HIGHWAY CLASSIFICATION

F.A.P. Rte. 343 - IL. Rte. 68
Functional Class: Other Principal Arterial
ADT: 30,300 (2008); 31,000 (2030)
ADTT: 930 (2008); 930 (2030)
DHW: 3,190 (2030)
Design Speed: 50 m.p.h.
Posted Speed: 45 m.p.h.

Lee Street
Functional Class: Major Collector
ADT: 1,500 (2010)
ADTT: N/A
DHW: N/A
Design Speed: 30 m.p.h.
Posted Speed: 30 m.p.h.

DESIGN STRESSES

FIELD UNITS

f'_c = 3,500 psi
f_y = 60,000 psi (Reinforcement)

LOADING HL-93

Allow 50#/sq. ft. for future wearing surface

DESIGN SPECIFICATIONS

2014 AASHTO LRFD Bridge Design Specifications, 7th Edition

WATERWAY INFORMATION

Drainage Area = 13785.6 acres
21,5400 sq.mi.

Existing Overtopping Elev. 645.87 @ Sta. 20+50
Proposed Overtopping Elev. 645.98 @ Sta. 21+50

Flood	Freq. Yr.	Discharge C.F.S.	Opening Sq. Ft.		Wet H.W.E.		Created Head (ft.)		Headwater Elev.	
			Exist.	Prop.	Exist.	Prop.	Exist.	Prop.	Exist.	Prop.
Design (Overtopping)	50	734.00	157.1	176.0	644.51	0.13	0.06	644.64	644.57	
Base	100	870.00	157.1	176.0	645.43	0.17	0.14	645.60	645.57	
Max. Calc.	500	1473.00	157.1	176.0	646.77	0.08	0.06	645.85	645.83	
					646.88	0.00	0.00	646.88	646.88	

Note: Waterway Information is preliminary and has not been approved. Subject to change.

PLAN

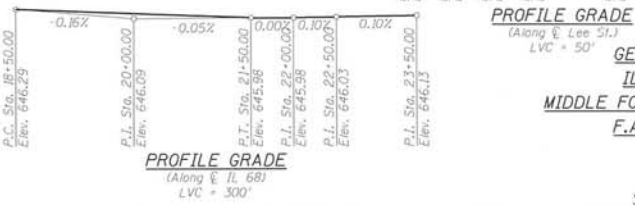

PROFILE GRADE

(Along E. Lee St.)
LVC = 50'



LOCATION SKETCH

GENERAL PLAN & ELEVATION
IL 68 (DUNDEE ROAD) OVER
MIDDLE FORK NORTH BRANCH CHICAGO RIVER
F.A.P. RTE. 343 - SEC 30T-1
COOK COUNTY
STATION 21+17.96
STRUCTURE NO. 016-2842

GENERAL PLAN & ELEVATION

STRUCTURE NO. 016-2842

SHEET NO. 1 OF 2 SHEETS

DATE	SECTION	COUNTY	TOTAL SHEET NO.
343	30T-1	COOK	115 77

CONTRACT NO. 60J13
ILLINOIS FED. AID PROJECT

STATE OF ILLINOIS
DEPARTMENT OF TRANSPORTATION



USER NAME:
DESIGNED: BIM/JRS
CHECKED: BT
DRAWN: TVB
CHECKED: 10/10/2014

REVISIONS
REVISED:
REVISED:
REVISED:
REVISED:

10/20/2014 11:58 AM C:\PROJECTS\2014\016-2842\016-2842-1.DWG

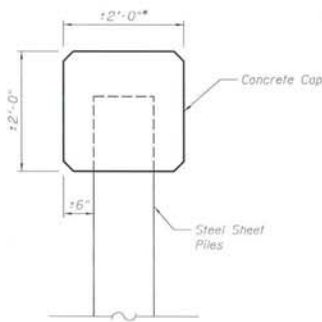

WINGWALL CONCRETE CAP DETAIL
 * Subject to the size of the sheet piling

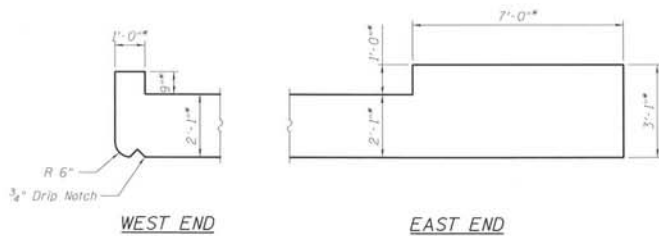

TOP SLAB HEADWALL DETAIL
 * To be refined in final design

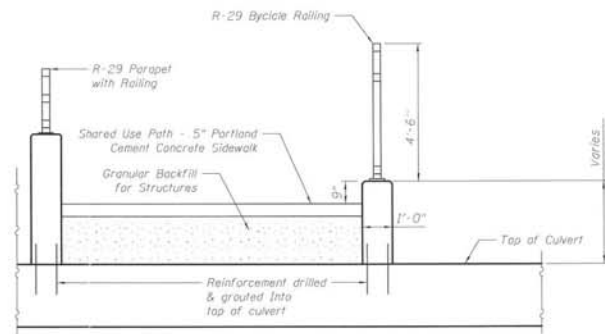

BICYCLE RAILING CONNECTION TO TOP OF CULVERT

APPROVED

AUG 31 2015

**AS A BASIS FOR
 PREPARATION OF DETAILED PLANS**

DETAILS

**IL 68 (DUNDEE ROAD) OVER
 MIDDLE FORK NORTH BRANCH CHICAGO RIVER
 F.A.P. RTE. 343 - SEC 30T-1
 COOK COUNTY
 STATION 21+17.96
 STRUCTURE NO. 016-2842**



USER NAME: j.mpherson
 PLOT SCALE: 1/8"=1'-0"
 PLOT DATE: 10/10/2014

DESIGNED - BCM/JRS
 CHECKED - BT
 DRAWN - TVB
 CHECKED - 10/10/2014

REVISED
 REVISED
 REVISED
 REVISED

**STATE OF ILLINOIS
 DEPARTMENT OF TRANSPORTATION**

**DETAILS
 STRUCTURE NO. 016-2842**

SHEET NO. 2 OF 2 SHEETS

F.A.P. RTE. 343	SECTION 30T-1	COUNTY COOK	TOTAL SHEETS 115	SHEET NO. 83
				CONTRACT NO. 60J13

ILLINOIS FED. AID PROJECT

APPENDIX E

Benchmark:
Square cut in the top of the northwest corner of the headwall in the southeast quadrant of the intersection of IL 68 and Lee Street. Elev. 646.61

Existing Structure:
Built in 1969. Existing Structure is a C.I.P. T-Type reinforced concrete retaining wall which is to partially remain. A new sheet piling retaining wall will be constructed in front of it. The east leg of IL 68 will be closed to traffic.

No Salvage

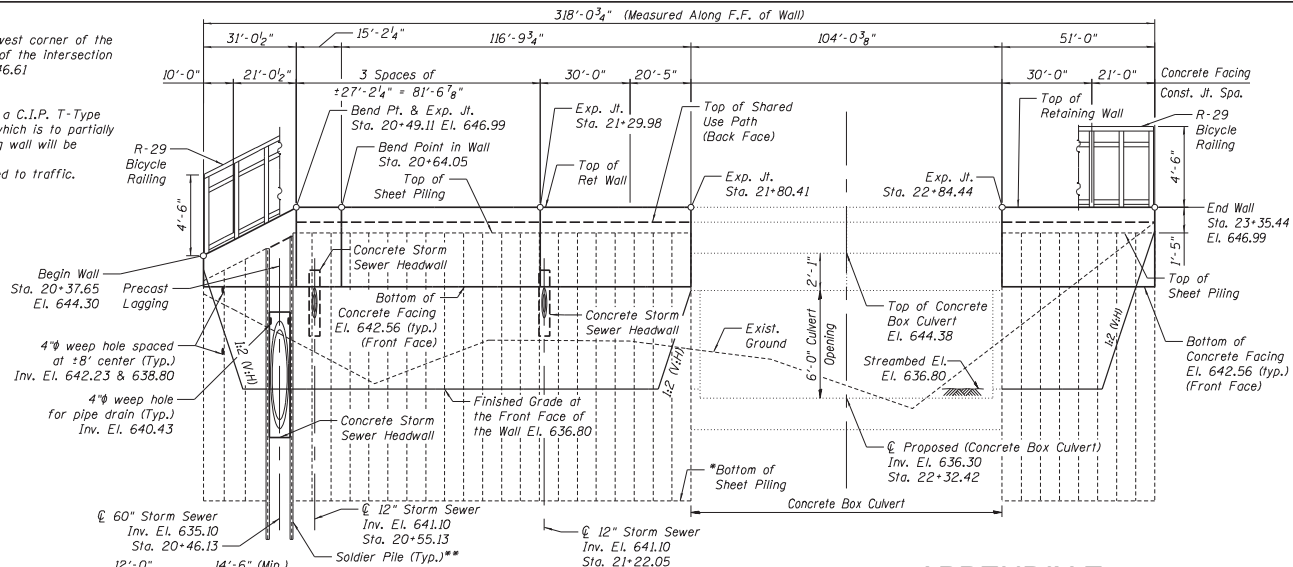

Note: All stations and offsets are referenced to IL-68, except as noted otherwise.

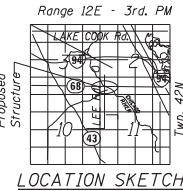
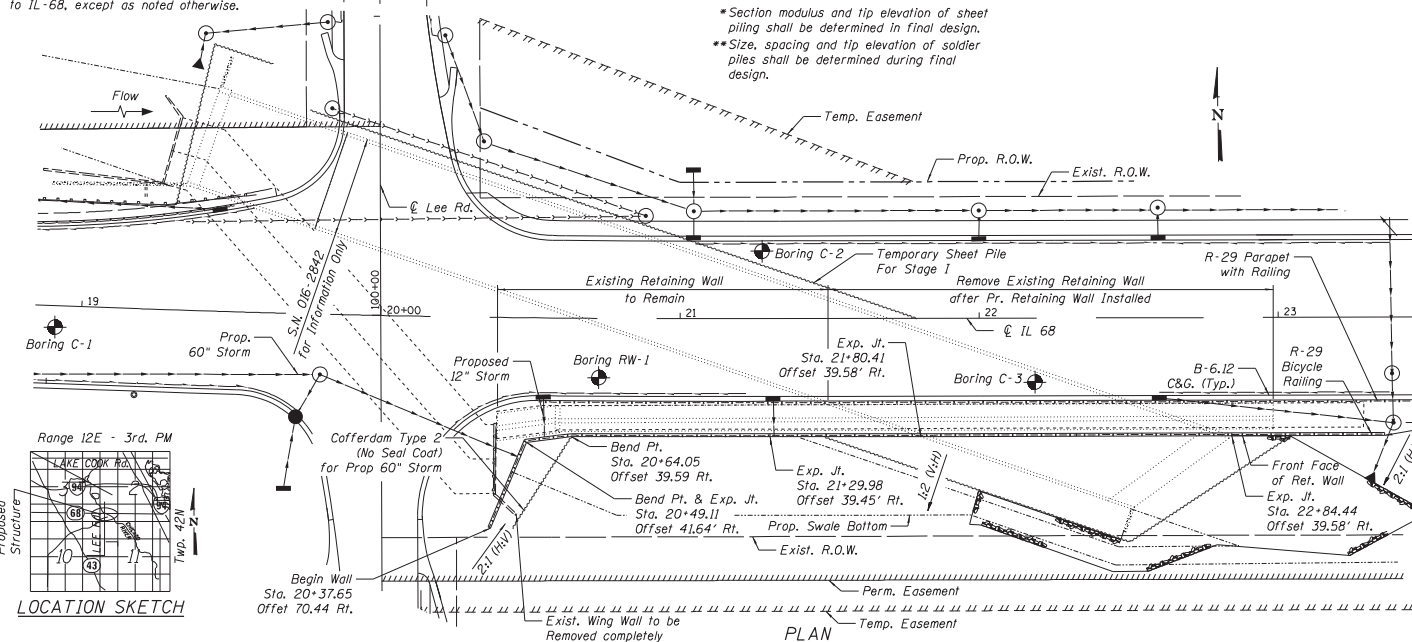

APPENDIX E

HIGHWAY CLASSIFICATION

F.A.P. Rte. 343 - IL Rte. 68
 Functional Class: Other Principal Arterial
 ADT: 30,300 (2008); 31,000 (2030)
 ADTT: 910 (2008); 930 (2030)
 DHV: 3,190 (2030)
 Design Speed: 50 m.p.h.
 Posted Speed: 45 m.p.h.

Lee Street
 Functional Class: Major Collector
 ADT: 1,150 (2010)
 ADTT: N/A
 DHV: N/A
 Design Speed: 30 m.p.h.
 Posted Speed: 30 m.p.h.

▽D.H.V.
 El. 645.27

▽E.W.S.E.
 El. 641.93

DESIGN STRESSES

FIELD UNITS

$f'_c = 3,500$ psi
 $f_y = 60,000$ psi (Reinforcement)
 $f_y = 50,000$ psi (ASTM A 72 Grade 50 Sheet Piling)
 $f_y = 50,000$ psi (ASTM M270, Grade 50 Soldier Piles)

DESIGN SPECIFICATIONS

2014 AASHTO LRFD Bridge
 Design Specifications, 7th Edition

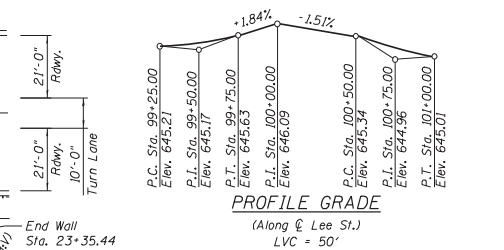
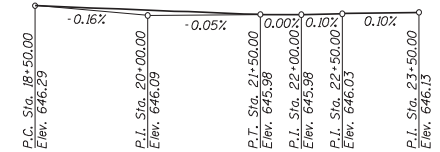

**GENERAL PLAN & ELEVATION
 RETAINING WALL ALONG IL 68 (DUNDEE ROAD)**

F.A.P. RTE. 343 - SEC 30T-1
 COOK COUNTY
 STATION 20+37.65 TO 23+35.44
 STRUCTURE NO. 016-2281



USER NAME = bmatos
 PLOT SCALE = N/A
 PLOT DATE = 7/14/2015

DESIGNED - BCM/JRS
 CHECKED - BT
 DRAWN - TVB
 CHECKED - 10/10/2014

REVISED
 REVISED
 REVISED
 REVISED

STATE OF ILLINOIS
 DEPARTMENT OF TRANSPORTATION

GENERAL PLAN & ELEVATION
 STRUCTURE NO. 016-2281

SHEET NO. 1 OF 2 SHEETS

F.A.P. RTE.	SECTION	COUNTY	TOTAL SHEETS	SHEET NO.
343	30T-1	COOK	117	84

CONTRACT NO. 60J13
 ILLINOIS FED. AID PROJECT

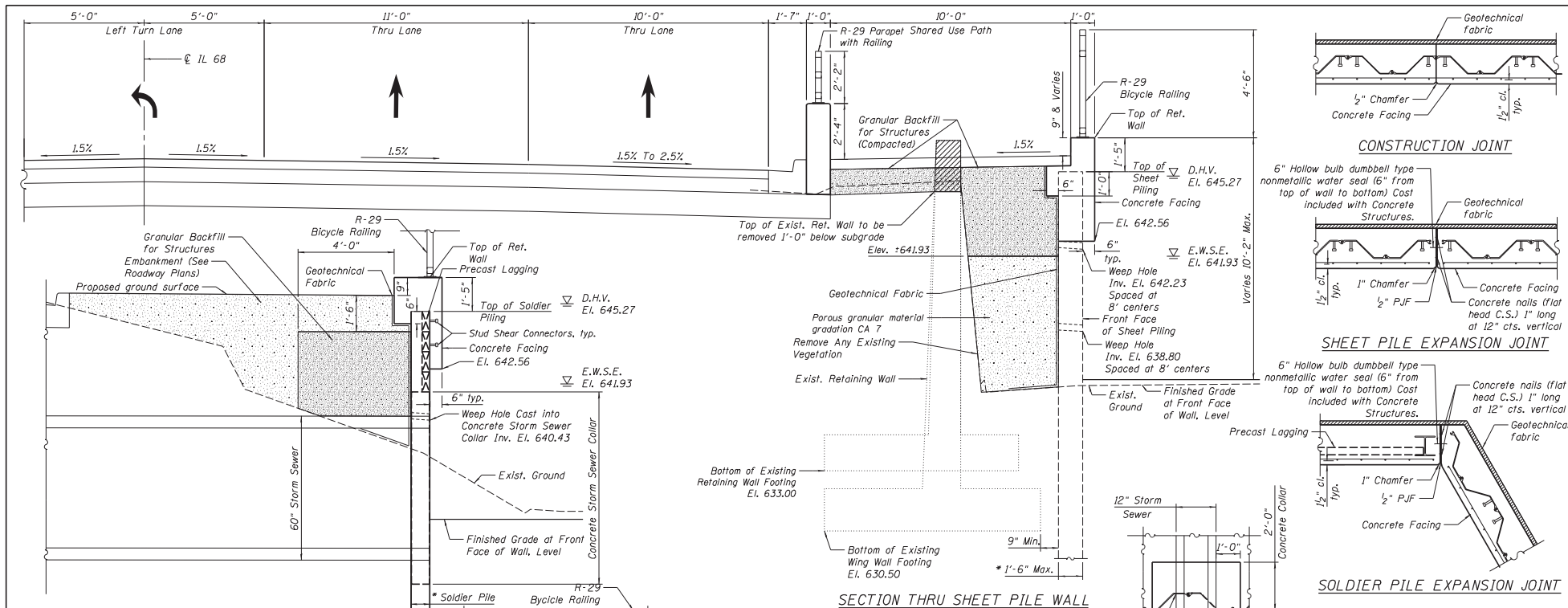

SECTION THRU SOLDIER PILE WALL
(Looking East)

* Size, spacing and tip elevation of soldier piles shall be determined during final design.

SECTION THRU SHEET PILE WALL
(Looking East)

* Section modulus and tip elevation of sheet piling shall be determined in final design.

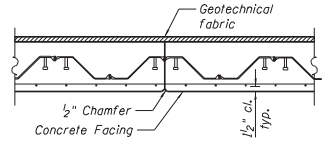

CONSTRUCTION JOINT

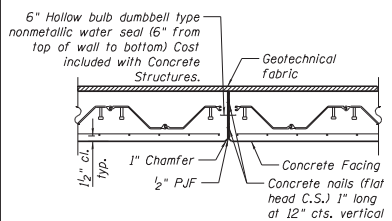

SHEET PILE EXPANSION JOINT

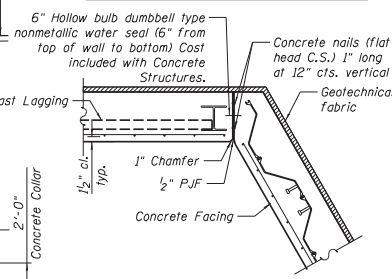

SOLDIER PILE EXPANSION JOINT

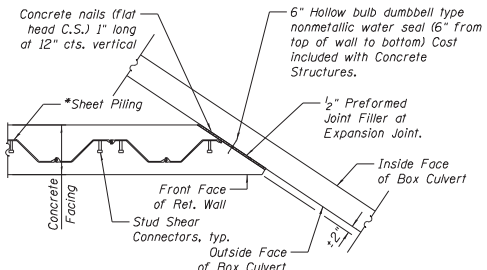

SHEET PILING WALL DETAIL AT BOX CULVERT

* Section modulus and tip elevation of sheet piling shall be determined in final design.

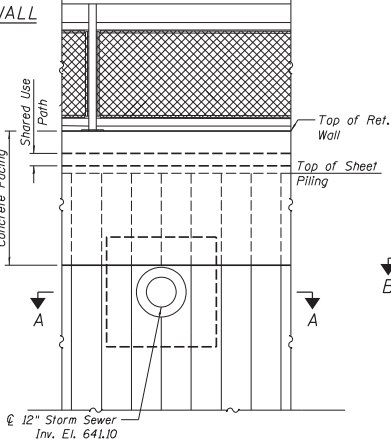

12" STORM SEWER DETAIL

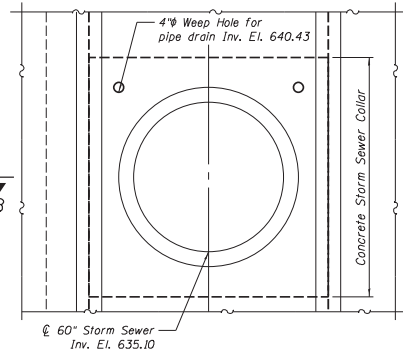

60" STORM SEWER DETAIL

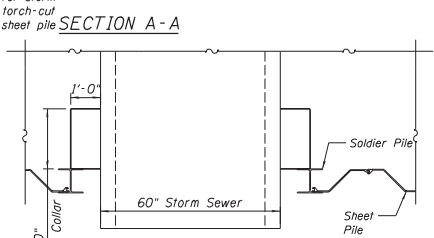

SECTION A-A

SECTION B-B

DETAILS

RETAINING WALL ALONG IL 68 (DUNDEE ROAD)
F.A.P. RTE. 343 - SEC 30T-1
COOK COUNTY
STATION 20+37.65 TO 23+35.44
STRUCTURE NO. 016-2281

FILE NAME: F:\A3\158\ILLINOIS\DRAWINGS\016-2281\016-2281-02.dwg

BLOOM COMPANIES, LLC
 100 W. Fulton Street, Suite 1100 • Chicago, IL 60601
 Phone: (312) 974-6000 Fax: (312) 974-6001

USER NAME: bmatos
 DESIGNED: BCM/JRS
 CHECKED: BT
 DRAWN: TVB
 CHECKED: 10/10/2014

DESIGNED: BCM/JRS
 CHECKED: BT
 DRAWN: TVB
 CHECKED: 10/10/2014

STATE OF ILLINOIS
DEPARTMENT OF TRANSPORTATION

DETAILS
STRUCTURE NO. 016-2281
 SHEET NO. 2 OF 2 SHEETS

F.A.P. RTE.	SECTION	COUNTY	TOTAL SHEETS	SHEET NO.
343	30T-1	COOK	117	85
				CONTRACT NO. 60J13
ILLINOIS FED. AID PROJECT				