

**STRUCTURE GEOTECHNICAL REPORT**

**FAP 332 (US-45) over N. Fork Saline River**

**Ex. S.N. 083-0001**

**Pr. S.N. 083-0073**

**F.A.P. ROUTE 332 (US-45)  
SECTION 29B-3  
SALINE COUNTY, ILLINOIS  
JOB NO. P-99-001-08  
CONTRACT NO. 78716  
PTB 193/032 WO 2  
KEG NO. 19-1143.02**

*Authored By:*

**Matthew D. Masterson, P.E.  
Christoph Opperman, E.I.  
Kaskaskia Engineering Group, LLC  
208 East Main Street, Suite 100  
Belleville, Illinois 62220  
[mmasterson@kaskaskiaeng.com](mailto:mmasterson@kaskaskiaeng.com)  
618-233-5877**



08/16/2022  
Exp. 11/30/2023

*Prepared for:*

**Crawford, Murphy & Tilly  
2750 West Washington Street  
Springfield, Illinois 62702**

November 6, 2020

Revised August 16, 2022



## TABLE OF CONTENTS

1.0	PROJECT DESCRIPTION AND PROPOSED STRUCTURE INFORMATION.....	1
1.1	Introduction.....	1
1.2	Project Description.....	1
1.3	Proposed Bridge Information .....	1
2.0	SITE INVESTIGATION, SUBSURFACE EXPLORATION, AND GENERALIZED SUBSURFACE CONDITIONS .....	1
	Table 2.0 - Boring Stations and Offsets.....	1
2.1	Subsurface Conditions.....	2
2.2	Bedrock .....	2
	Table 2.2 - Elevation of Top of Clay Shale .....	2
2.3	Groundwater .....	2
3.0	GEOTECHNICAL EVALUATIONS .....	2
3.1	Settlement .....	2
3.2	Slope Stability .....	3
	Table 3.2 - Slope Stability Critical FOS .....	3
3.3	Seismic Considerations .....	3
	Table 3.3 - Summary of Seismic Parameters .....	4
3.4	Scour .....	4
	Table 3.4 - Design Scour Elevations .....	4
3.5	Liquefaction .....	4
4.0	FOUNDATION EVALUATIONS AND DESIGN RECOMMENDATIONS .....	5
4.1	General Feasibility .....	5
	Table 4.1 - Preliminary Design Loads .....	5
4.2	Pile Supported Foundations.....	5
	Table 4.2.2 - Estimated Pile Lengths for HP 12x53 H-Pile .....	6
	Table 4.2.3 - Estimated Pile Lengths for HP 12x63 H-Pile .....	6
	Table 4.2.4 - Estimated Pile Lengths for HP 14x73 H-Pile .....	6
	Table 4.2.5 - Estimated Pile Lengths for HP 14x89 H-Pile .....	7
4.3	Lateral Pile Response.....	9
	Table 4.3 - Soil Parameters for Lateral Pile Load Analysis.....	9
5.0	CONSTRUCTION CONSIDERATIONS.....	10
5.1	Construction Activities.....	10
5.2	Site and Soil Conditions.....	10
5.3	Foundation Construction.....	10
5.4	Cofferdam Construction.....	10
6.0	COMPUTATIONS .....	10
7.0	GEOTECHNICAL DATA.....	11
8.0	LIMITATIONS.....	11

## **EXHIBITS**

- Exhibit A - Location Map
- Exhibit B - Type, Size, and Location Plan (TS&L)
- Exhibit C - Boring Logs
- Exhibit D - Subsurface Profile
- Exhibit E - SLOPE/W Slope Stability Analysis
- Exhibit F - Liquefaction Analyses Results
- Exhibit G - Pile Length/Pile Type

## 1.0 PROJECT DESCRIPTION AND PROPOSED STRUCTURE INFORMATION

### 1.1 Introduction

The geotechnical study summarized in this report was performed for the proposed 3-span structure for US-45 over North Fork Saline River in Saline County, Illinois. The purpose of this report is to present design and construction recommendations for the proposed structure.

### 1.2 Project Description

The project consists of construction of a 3-span structure (Proposed SN 083-0073) carrying US-45 over North Fork Saline River. The general location of the structure is shown on a Location Map, Exhibit A. The site lies within the limits of the Third Principal Meridian (T. 7S R. 7E Section 24) within the Mt. Vernon Hill Country of the Till Plains section of the Central Lowland Province.

### 1.3 Proposed Bridge Information

The proposed structure (SN 083-0073) located at US-45 over North Fork Saline River will consist of a 3-span structures built on a 0° skew from the centerline of US-45 at the local tangent to Station 721+23.00. The structure will have a width of 42'-10". The structure will be located at approximate station 721+23.00 (US-45). Integral abutments and piers are proposed for the substructures.

The structure will measure 231'-0", from back-to-back of abutments. The structure will support two 12' lanes, with shoulder widths of 8'-0". The structure is to be removed and replaced using staged construction to always maintain one lane of traffic. Further substructure details will be based on the findings of this Structure Geotechnical Report (SGR).

## 2.0 SITE INVESTIGATION, SUBSURFACE EXPLORATION, AND GENERALIZED SUBSURFACE CONDITIONS

The site investigation was performed by the Illinois Department of Transportation (IDOT).

Two standard penetration test (SPT) borings, designated 1-S and 2-S, were drilled between May 11 and 17, 2010. The stations and offsets as listed on the borings have been revised as summarized in Table 2.0. The previous stationing (Listed on the Boring Logs) is referenced under the new stationing. The boring locations are shown on the Type, Size, and Location Plan (TS&L), Exhibit B, as provided by Kaskaskia Engineering Group, LLC. (KEG). Detailed information regarding the nature and thickness of the soils and bedrock encountered and the results of the field sampling and laboratory testing are shown on the Boring Logs, Exhibit C. A soil profile for borings 1-S and 2-S can be found under Subsurface Profile, Exhibit D.

**Table 2.0 - Boring Stations and Offsets**

Designation	Stationing	Offset from Proposed Centerline	Surface Elevation (ft.)
1-S	722+48 - Revised (739+97)	27' Rt - Revised (10' Lt CL)	369.1
2-S	719+79 - Revised (737+28)	48' Rt - Revised (11' Lt CL)	368.4

## 2.1 Subsurface Conditions

The stratigraphy of the borings exhibited layers of silty clay, clay, silt, sand, and clay shale. In general, the lithologic succession beneath the ground surface is as follows:

1. Clay - From the surface of each boring, approximately 15 to 15.5 ft. of clay was encountered. The driving resistances (N-values) ranged from 3 to 24 blows per foot (bpf), and unconfined compressive strength (Qu) values ranged between 0.6 to 6.1 tons per square foot (tsf). The moisture contents ranged from 18 to 31 percent.
2. Silty Clay/Silty Clay Loam - Below the clay, silty clay/silty clay loam was encountered to depths of 70 to 103 feet. The N-values ranged from 2 to 27 bpf, and Qu values ranged from 0.2 to 3.5 tsf. The moisture contents varied from 18 to 28 percent.
3. Clay - Boring 1-S encountered a layer of stiff to medium stiff clay below the silty clay layers to a depth of 99.5 feet. The N-values ranged from 2 to 24 bpf, and the moisture contents varied from 24 to 28 percent. Qu values ranged from
4. Sand Loam/Sandy Clay Loam - Below the clays in Boring 1-S, sand loam and sandy clay loam were encountered to a depth of 109.5 feet. The N-value of this layer was 0 bpf. The moisture content was 25 percent. The Qu value was 0.2 tsf.
5. Clay Shale - Below the sand loam/sandy clay loam in Boring 1-S and below the Silty Clay Loam in 2-S, clay shale was encountered in boring 1-S and 2-S, at depths of 103.5 to 109.5 ft. with blow counts of 100 blows for 2 to 8-inches of penetration.

## 2.2 Bedrock

Table 2.2 shows the elevations of top of clay shale for Borings 1-S and 2-S.

**Table 2.2 - Elevation of Top of Clay Shale**

Designation	Station	Offset	Top of Clay Shale Elevation (ft.)
1-S	722+48 - Revised (739+97)	27' Rt - Revised (10' Lt CL)	257.1
2-S	719+79 - Revised (737+28)	48' Rt - Revised (11' Lt CL)	265.4

## 2.3 Groundwater

Groundwater was encountered in Borings 1-S and 2-S at El. 334.1 and El. 330.9. The surface elevation the North Fork Saline River at the time of drilling was El. 339.1.

## 3.0 GEOTECHNICAL EVALUATIONS

### 3.1 Settlement

Since no significant grading or changes to the existing roadway elevations are anticipated for the proposed structure and the soil characteristics as detailed in the borings provided, it is estimated

that with proper preparation and construction the structure will experience settlements of less than 0.25 inches. Therefore, no settlement calculations were performed for the proposed structure.

### 3.2 Slope Stability

The proposed construction of the new US-45 over North Fork Saline River will result in new end-slopes at the abutment locations and new side-slopes for the approach embankments.

The proposed abutments are integral abutments with end-slopes at 1 Vertical to 2 Horizontal (1V:2H). Slope stability of the end-slopes was analyzed using SLOPE/W; the soil properties at the site, including those in Borings 1-S and 2-S; and end-slope geometrics. KEG modeled the slopes at both abutment locations. Three conditions were modeled for each: end-of-construction (E-O-C), long-term (L-T), and the seismic condition. A critical factor of safety (FOS) was calculated for each condition. According to current standard of practice, the target FOS is 1.5 for end-of-construction and long-term slope stability, and 1.0 for the seismic condition.

In order to model the E-O-C condition, undrained soil strength parameters were used with a friction angle of 0° assumed for cohesive soils. Drained soil strength parameters with assumed friction angles ranging from 12° to 34° were used to model the L-T and Seismic cases where excess pore water pressure from construction has dissipated. For clay and silty clay materials, a nominal cohesion between 50 and 200 psf was included in the drained strength parameters.

The Modified Bishop Method, which generates circular-arc failure surfaces, was used to calculate the critical failure surfaces and FOS for the proposed conditions. The FOS obtained in the analysis are shown in Table 3.2. SLOPE/W program output from this analysis can be found in SLOPE/W Slope Stability Analysis, Exhibit E.

**Table 3.2 - Slope Stability Critical FOS**

Location	Slope	Calculated Critical FOS		
		End-of-Construction	Long-Term	Seismic
North Abutment	1V:2H	1.7	1.5	1.0
South Abutment	1V:2H	2.6	1.5	1.0

In order for the seismic condition to achieve the minimum required factor of safety of 1.0, the proposed piles for the abutments and piers, and the existing timber piles (to remain in place) were included in the stability model. The stability analysis showed that a maximum pile spacing of 8 feet is required at both the abutments and piers. The results of the analysis, as provided in Table 3.2, indicate an acceptable FOS will exist at the north and south abutments under short-term, long-term, and seismic conditions.

### 3.3 Seismic Considerations

The determination of Seismic Site Class was based on the method described by IDOT AGMU Memo 09.1 - Seismic Site Class Definition and the IDOT provided spreadsheet titled: '*Seismic Site Class Determination*.' Using these resources, the controlling global site class for this project is Soil Site Class E.

Additional seismic parameters were calculated for use in design of the structure and evaluation of liquefaction potential. Published information and mapping (<http://seismicmaps.org/>), including software directly applicable to the AASHTO Guide Specifications for LRFD Seismic Bridge Design, was used to develop the parameters for the project site location. The values, based on Soil Site Class E, are summarized below.

**Table 3.3 - Summary of Seismic Parameters**

Parameter	Value
Soil Site Class	E
Spectral Response Acceleration, 0.2 Sec, $S_{DS}$	0.884g (Site Class E)
Spectral Response Acceleration, 1.0 Sec, $S_{D1}$	0.484g (Site Class E)
Seismic Performance Zone	2

\* $S_{DS}$  and  $S_{D1}$  values shown as provided by IDOT

As indicated in the table above, the Seismic Performance Zone is 2, based on  $S_{D1}$  and Table 3.15.2 in the IDOT Bridge Manual, the Soil Site Class E, and Figure 2.3.10-2 in the IDOT Bridge Manual. Because these structures are considered critical, the appropriate Response Modification Factors as indicated in the AASHTO Bridge Design Specifications, Table 3.10.7.1-1 shall be applied.

### 3.4 Scour

The design scour elevations for the proposed structure are shown in Table 3.4. Class A4 stone riprap will be placed on the surface of the proposed abutment end-slopes and around each of the pier substructures on the surface, to reduce the potential for future scour. The scour depths at the pier locations have been reduced accordingly based on the cohesive soils observed in the borings.

**Table 3.4 - Design Scour Elevations**

Event/Limit State	Design Scour Elevations (ft.)				Item 113
	South Abutment	Pier 1	Pier 2	North Abutment	
$Q_{100}$	363.33	318.75	317.12	363.31	5
$Q_{200}$	363.33	315.17	312.74	363.31	
Design	363.33	318.75	317.12	363.31	
Check	363.33	315.17	312.74	363.31	

### 3.5 Liquefaction

Per the Geotechnical Manual, due to the location of this structure and the seismic conditions resulting in an SPZ 2, a liquefaction analysis was performed using the liquefaction analysis worksheet provided by IDOT BBS Central Geotechnical Unit and procedures outlined in AGMU 10.1 - Liquefaction Analysis. The PGA and  $M_w$  pairs to be used were obtained from the deaggregation data of the seismic hazard for the site, by accessing the USGS website: <http://earthquake.usgs.gov/hazards/interactive/> for both New Madrid Seismic Zone (NMSZ) and Central Eastern United States (CEUS) models. The deaggregation data indicated a NMSZ maximum Magnitude of 7.5, contributing 7.1% to the hazard for this site. The Peak Horizontal Ground Surface Acceleration coefficient was set to the NMSZ PGA (0.118g) calculated in the

IDOT Liquefaction Analysis Spreadsheet.

The soil profiles for Borings 1-S and 2-S were analyzed for the south and north abutments, respectively. Based off of the soil descriptions in the boring logs and typical soil characteristics, it was assumed that the Plasticity Index of the silty clay, silty clay loam, and clay materials is greater than 12 and therefore not considered to be susceptible to liquefaction. Therefore, no reduction for liquefaction was considered for the pile design capacities or other foundation considerations for the piers or abutments.

A summary of the liquefaction analysis including each specific run is included in Exhibit F, Liquefaction Analyses Results.

## **4.0 FOUNDATION EVALUATIONS AND DESIGN RECOMMENDATIONS**

### **4.1 General Feasibility**

Due to the depth to bedrock and anticipated foundation loads, driven piles appear applicable for support of the bridge substructures. The Modified IDOT Static Method of Estimating Pile Length, as provided by Illinois Department of Transportation – Bureau of Bridges and Structures (IDOT BBS) Foundations and Geotechnical Unit, was used to estimate the capacities of the driven piles in clay shale.

The preliminary design loads, as provided by KEG, are provided in Table 4.1.

**Table 4.1 - Preliminary Design Loads**

<b>Substructure Unit</b>	<b>Factored Reactions (kips)</b>
Abutments	1100
Piers	2600

### **4.2 Pile Supported Foundations**

The foundations supporting the proposed bridges must provide sufficient support to resist dead, live, and wind loads, including seismic loadings. Based on the encountered subsurface conditions, the Modified IDOT Static Method of Estimating Pile Length provided by IDOT BBS Foundations and Geotechnical Unit, and the information available to date, KEG recommends using H-piles or Metal Shell piles. The Modified IDOT Static Method uses the LRFD Pile Design Guide Procedure to estimate the pile lengths (Pile Length/Pile Type, Exhibit G).

The estimated pile lengths for the pile types considered are shown in Table 4.2.1 through 4.2.5 below and under Exhibit G, Pile Length/Pile Type. The Nominal Required Bearing (RN) represents the resistance the pile will experience during driving and will assist the contractor in selecting a proper hammer size. The Factored Resistance Available (RF) documents the net long-term axial factored pile capacity available at the top of the pile to support factored substructure loadings.

As discussed in sections above and shown in the tables, including under Pile Length/Pile Type, Exhibit G; down-drag and liquefaction do not impact the subsurface soils at this site and have not been included in the pile strength estimates. Due to the anticipated scour elevations at the piers, a reduction in factored resistance available was taken into consideration at the Pier locations.



**Table 4.2.1 - Estimated Pile Lengths for HP 10x42 H-Pile**

	<b>R<sub>n</sub> Nominal Required Bearing (kips)</b>	<b>R<sub>F</sub> Allowable Resistance Available (LRFD Criteria) (kips)</b>	<b>Estimated Pile Length (ft.)</b>	<b>Assumed Pile Cut-off Elevation (ft.)</b>
South Abutment	335	179	77	365.30
Pier 1	335	174	72	335.50
Pier 2	335	178	80	335.50
North Abutment	335	180	86	365.31

**Table 4.2.2 - Estimated Pile Lengths for HP 12x53 H-Pile**

	<b>R<sub>n</sub> Nominal Required Bearing (kips)</b>	<b>R<sub>F</sub> Allowable Resistance Available (LRFD Criteria) (kips)</b>	<b>Estimated Pile Length (ft.)</b>	<b>Assumed Pile Cut-off Elevation (ft.)</b>
South Abutment	418	229	87	365.30
Pier 1	418	217	72	335.50
Pier 2	418	223	80	335.50
North Abutment	418	224	96	365.31

**Table 4.2.3 - Estimated Pile Lengths for HP 12x63 H-Pile**

	<b>R<sub>n</sub> Nominal Required Bearing (kips)</b>	<b>R<sub>F</sub> Allowable Resistance Available (LRFD Criteria) (kips)</b>	<b>Estimated Pile Length (ft.)</b>	<b>Assumed Pile Cut-off Elevation (ft.)</b>
South Abutment	497	273	101	365.30
Pier 1	497	260	73	335.50
Pier 2	497	266	81	335.50
North Abutment	497	273	108	365.31

**Table 4.2.4 - Estimated Pile Lengths for HP 14x73 H-Pile**

	<b>R<sub>n</sub> Nominal Required Bearing (kips)</b>	<b>R<sub>F</sub> Allowable Resistance Available (LRFD Criteria) (kips)</b>	<b>Estimated Pile Length (ft.)</b>	<b>Assumed Pile Cut-off Elevation (ft.)</b>
South Abutment	578	318	101	365.30
Pier 1	578	303	73	335.50
Pier 2	578	309	81	335.50
North Abutment	578	318	108	365.31

**Table 4.2.5 - Estimated Pile Lengths for HP 14x89 H-Pile**

	<b>R<sub>n</sub> Nominal Required Bearing (kips)</b>	<b>R<sub>F</sub> Allowable Resistance Available (LRFD Criteria) (kips)</b>	<b>Estimated Pile Length (ft.)</b>	<b>Assumed Pile Cut-off Elevation (ft.)</b>
South Abutment	705	388	102	365.30
Pier 1	705	372	75	335.50
Pier 2	705	379	83	335.50
North Abutment	705	388	109	365.31

**Table 4.2.6 - Estimated Pile Lengths for MS 12"  $\phi$  .25" Walls**

	<b>R<sub>n</sub> Nominal Required Bearing (kips)</b>	<b>R<sub>F</sub> Allowable Resistance Available (LRFD Criteria) (kips)</b>	<b>Estimated Pile Length (ft.)</b>	<b>Assumed Pile Cut-off Elevation (ft.)</b>
South Abutment	303	167	47	365.30
	342	188	52	
	*377	207	57	
Pier 1	243	118	47	335.50
	280	138	57	
	*288	143	67	
Pier 2	258	133	56	335.50
	278	144	66	
	*305	159	76	
North Abutment	309	170	56	365.31
	335	184	61	
	*362	199	66	

❖ Metal Shell does not achieve maximum nominal capacity at the piers prior to reaching the underlying shale where driving may damage pile

**Table 4.2.7 - Estimated Pile Lengths for MS 14"  $\phi$  .25" Walls**

	<b>R<sub>n</sub> Nominal Required Bearing (kips)</b>	<b>R<sub>F</sub> Allowable Resistance Available (LRFD Criteria) (kips)</b>	<b>Estimated Pile Length (ft.)</b>	<b>Assumed Pile Cut-off Elevation (ft.)</b>
South Abutment	359	198	47	365.30
	404	222	52	
	*444	244	57	
Pier 1	286	139	47	335.50
	327	162	57	
	*337	167	67	
Pier 2	302	156	56	335.50
	324	168	66	
	*360	188	76	
North Abutment	367	202	56	365.31
	394	216	61	
	426	234	66	

❖ Metal Shell does not achieve maximum nominal capacity at the piers prior to reaching the underlying shale where driving may damage pile

**Table 4.2.8 - Estimated Pile Lengths for MS 14"  $\phi$  .312" Walls**

	<b>R<sub>n</sub> Nominal Required Bearing (kips)</b>	<b>R<sub>F</sub> Allowable Resistance Available (LRFD Criteria) (kips)</b>	<b>Estimated Pile Length (ft.)</b>	<b>Assumed Pile Cut-off Elevation (ft.)</b>
South Abutment	497	273	67	365.30
	529	291	72	
	*558	307	77	
Pier 1	286	139	47	335.50
	327	162	57	
	*337	167	67	
Pier 2	302	156	56	335.50
	324	168	66	
	*360	188	76	
North Abutment	477	262	71	365.31
	512	282	76	
	565	311	86	

❖ Metal Shell does not achieve maximum nominal capacity at the piers prior to reaching the underlying shale where driving may damage pile

**Table 4.2.9 - Estimated Pile Lengths for MS 16"  $\phi$  .312" Walls**

	$R_n$ Nominal Required Bearing (kips)	$R_F$ Allowable Resistance Available (LRFD Criteria) (kips)	Estimated Pile Length (ft.)	Assumed Pile Cut-off Elevation (ft.)
South Abutment	571	314	67	365.30
	608	335	72	
	641	352	77	
Pier 1	330	161	47	335.50
	374	185	57	
	*385	191	67	
Pier 2	347	179	56	335.50
	371	192	66	
	*417	218	76	
North Abutment	552	304	71	365.31
	590	324	76	
	647	356	86	

❖ Metal Shell does not achieve maximum nominal capacity at the piers prior to reaching the underlying shale where driving may damage pile

1

KEG recommends one (1) test pile be performed near Pier 2. A test pile is performed prior to production driving so that actual, on-site field data can be gathered to further evaluate pile driving requirements for the project. This also is the manner in which the contractor's proposed equipment and methodologies identified in their Pile Installation Plan can be assessed.

### 4.3 Lateral Pile Response

Generally, the geotechnical engineer provides soil parameters to the structural engineer so that an L-Pile program or other approved software can be used for the lateral or displacement analysis of the foundations. Table 4.3 is included for the structural engineer's use in evaluating lateral pile response. The values were estimated based on the descriptions as listed on the boring logs. No specific hydrometer analyses were performed on the site soils.

**Table 4.3 - Soil Parameters for Lateral Pile Load Analysis**

Boring	Elev. at Bottom of Layer	$\gamma$ (pcf)	Short Term		Long Term		N	% fines < #200	K (pci)	$\epsilon_{50}$
			$\phi$ (deg.)	c (psf)	$\phi$ (deg.)	c (psf)				
1-S	354.6	125	0	1600	26	150	7	80	500	0.007
	334.6	125	0	3900	26	150	18	80	1000	0.005
	314.6	110	0	500	28	100	4	65	100	0.010
	279.6	120	0	2400	26	100	15	65	1000	0.005
	259.6	115	0	400	28	50	1	65	30	0.020
	257.1	110	34	2500	34	200	54	3	125	--

Boring	Elev. at Bottom of Layer	γ (pcf)	Short Term		Long Term		N	% fines < #200	K (pci)	ε50
			Φ (deg.)	c (psf)	Φ (deg.)	c (psf)				
	240.0	125	12	5000	12	5000	100	--	2000	0.004
2-S	353.4	125	0	1300	26	200	4	80	500	0.007
	334.4	125	0	4400	26	150	17	80	2000	0.004
	318.4	120	0	700	26	100	7	65	100	0.010
	298.4	120	0	2700	26	100	19	65	1000	0.005
	278.4	125	0	1600	26	100	11	80	500	0.007
	265.4	110	0	200	28	50	5	65	30	0.020
	257.9	125	12	5000	12	5000	100	--	2000	0.004

## 5.0 CONSTRUCTION CONSIDERATIONS

### 5.1 Construction Activities

Construction activities should be performed in accordance with the current IDOT Standard Specifications for Road and Bridge Construction and any pertinent Special Provisions or Policies.

### 5.2 Site and Soil Conditions

Should any bridge or embankment design considerations assumed by either IDOT or KEG change, KEG should be contacted to determine if the recommendations stated in this report still apply. See Section 205 - Embankment, of the Standard Specifications of Road and Bridge Construction for specific information on embankment construction.

### 5.3 Foundation Construction

Conventional pile driving equipment and methodologies should be assumed.

A Joint Utility Locating Information for Excavators (J.U.L.I.E.) locate shall be conducted to determine if any underground utilities are present in the area of the proposed structure prior to construction. If utilities become a problem during construction, the appropriate owner shall be contacted immediately.

### 5.4 Cofferdam Construction

Cofferdams will be required at the proposed pier locations. The estimated water surface elevation is greater than 6 ft. above the bottom elevation of the substructure. Therefore, Type 2 cofferdams will be required. All cofferdams are required to be dewatered. The foundation soils below the pier encasements are anticipated to be cohesive and sealcoats should not be required.

## 6.0 COMPUTATIONS

Computations and analyses for special circumstances, if any, are included as exhibits. Please refer to each section of the report for reference to the exhibit containing any such calculations or analysis used.

## **7.0 GEOTECHNICAL DATA**

Soil borings can be found in Exhibit C. The Subsurface Profile can be found in Exhibit D.

## **8.0 LIMITATIONS**

The recommendations provided herein are for the exclusive use of CM&T and IDOT. They are specific only to the project described and are based on the subsurface information obtained by IDOT at two boring locations within the bridge area in 2010; KEG's understanding of the project as described herein, and geotechnical engineering practice consistent with the standard of care. No other warranty is expressed or implied. KEG should be contacted if conditions encountered during construction are not consistent with those described.

**EXHIBIT A**  
**LOCATION MAP**

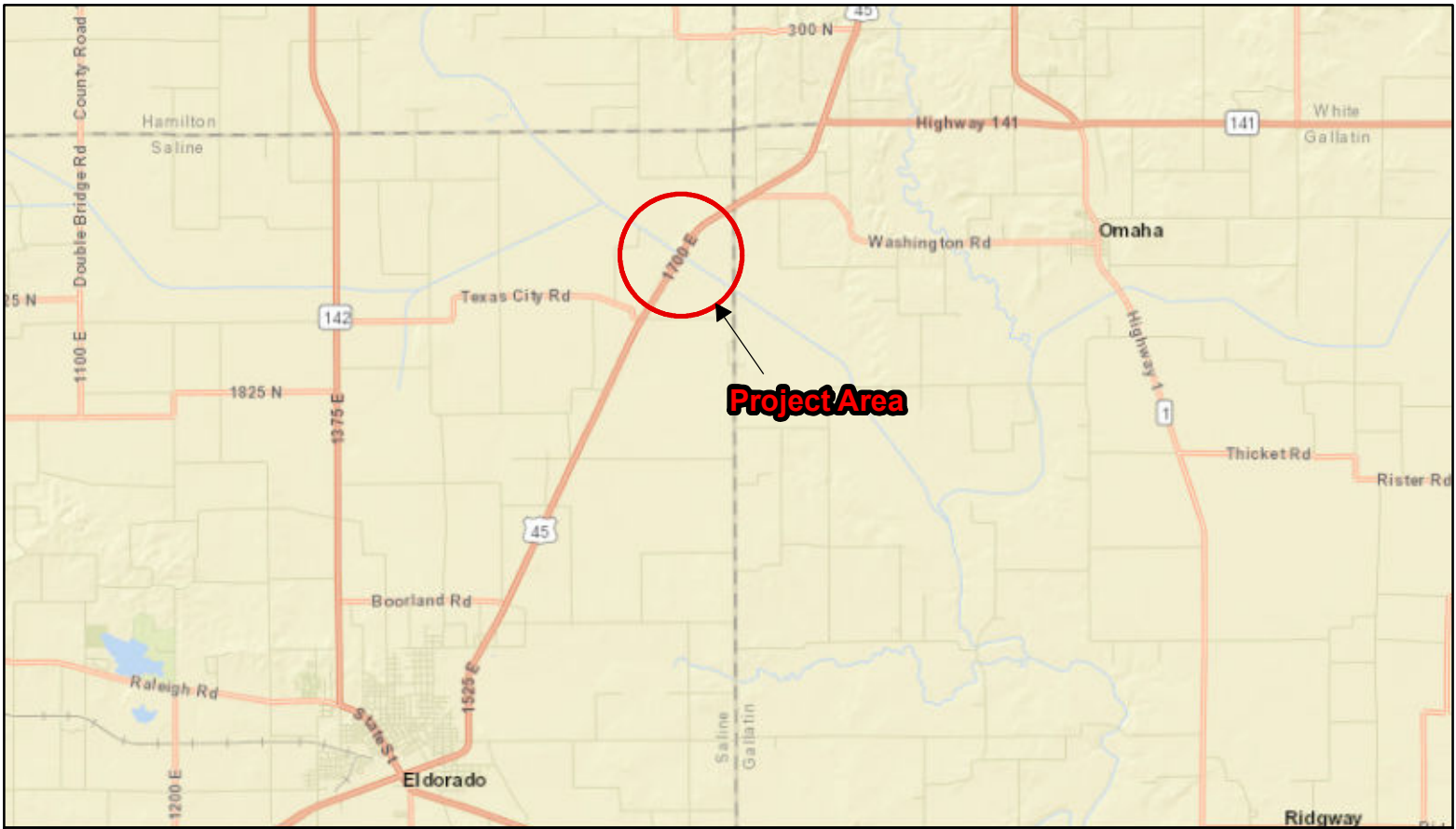

**LOCATION MAP**  
**Bridge Improvement Project**  
**US 45 (FAP 332)**  
**SN 083-0001**  
**Saline County, Illinois**

**Exhibit No.**

**A**

KEG JOB #19-1143.02



**EXHIBIT B**

**TYPE, SIZE, AND LOCATION PLAN (TS&L)**

**BENCHMARK:**

Chiseled "□" on top of wingwall of NE corner of Structure 083-0001 along US 45, Sta. 722+20, Offset 17' Rt., Elevation 370.51.

**SALVAGE:**

None

**EXISTING STRUCTURE:**

SN 083-0001 was originally built in 1953 under SB1-1, Section 29-B-Y. The structure is a 3-span continuous bridge with stub abutments and an overall length of 221'-11" from back to back of abutments. The superstructure consists of a 7" thick slab supported on haunched reinforced concrete T-beams. The width of the structure is 33'-8" out to out of deck. The piers are reinforced concrete solid wall piers on treated timber piles. The structure is to be removed and replaced using stage construction to maintain one lane of traffic open at all times.

**DESIGN SPECIFICATIONS:**

2020 AASHTO LRFD Bridge Design Specifications, 9th Edition.

**LOADING HL-93:**

Allow 50 #/sq.ft. for future wearing surface.

**SEISMIC DATA:**

Seismic Performance Zone (SPZ) = 3  
Design Spectral Acceleration at 1.0 sec. ( $S_{D1}$ ) = 0.319g  
Design Spectral Acceleration at 2.0 sec. ( $S_{D5}$ ) = 0.755g  
Soil Site Class = D

**DESIGN STRESSES:**

**FIELD UNITS**  
f'c = 4,000 psi (superstructure)  
f'c = 3,500 psi  
fy = 60,000 psi (reinforcement)  
fy = 50,000 psi (M270 Grade 50W)

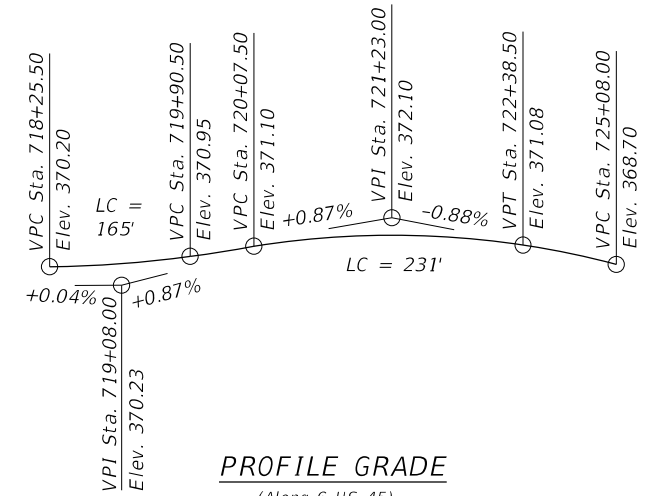
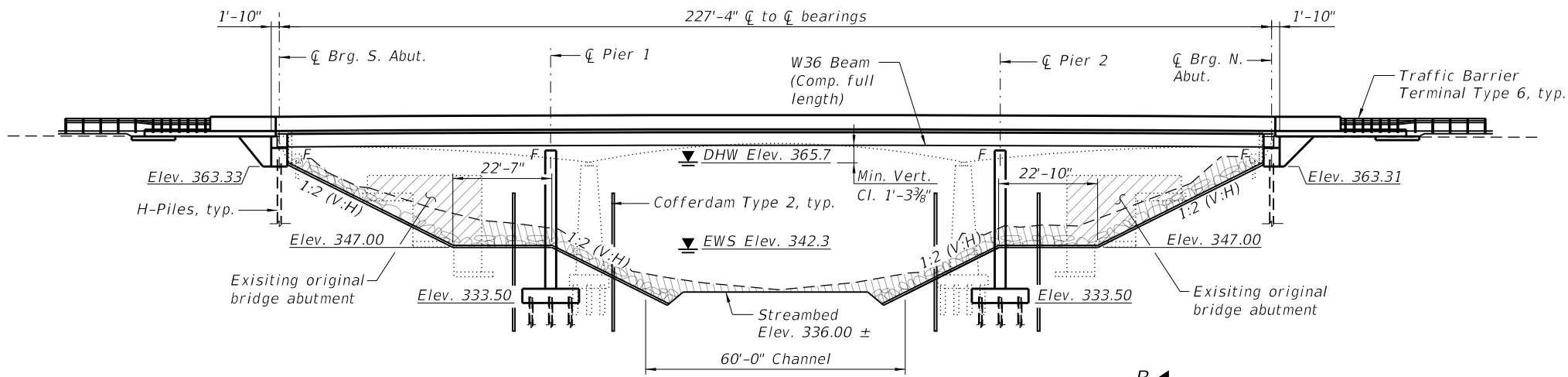

**PROFILE GRADE**  
(Along  $\bar{C}$  US 45)

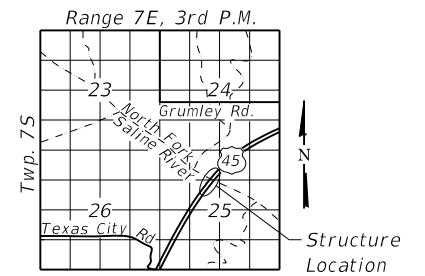

**LOCATION SKETCH**

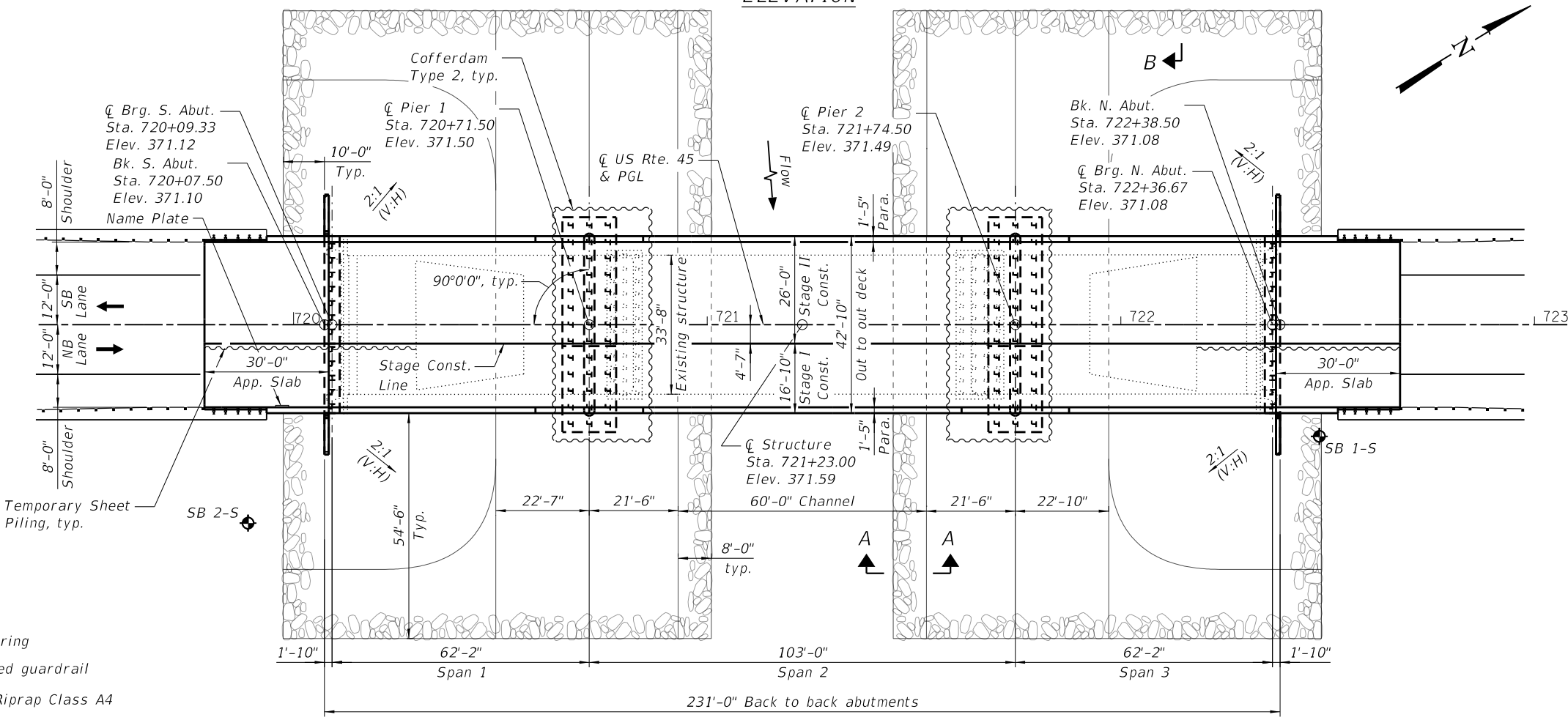

**PLAN**

**LEGEND**

- Soil Boring
- Proposed guardrail
- Stone Riprap Class A4
- Concrete Removal
- Channel Excavation (See Roadway Plans)

Notes:  
1. See Sheet 2 of 25 for Section A-A and B-B.  
2. See Roadway Plans for Channel Excavation limits and quantity.

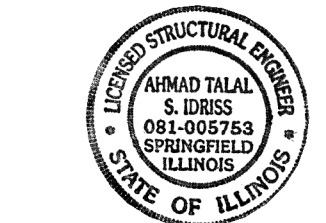

Ahmad T. Idress  
EXP. 11-30-2022

"I certify that to the best of my knowledge, information and belief, this design is structurally adequate for the design loading shown on the plans. The design is an economical one for the style of the structure and complies with the requirements of the current Design Specifications listed."

**GENERAL PLAN**  
**US ROUTE 45**  
**OVER NORTH FORK SALINE RIVER**  
**FAP ROUTE 332 - SECTION (29B-3)**  
**SALINE COUNTY**  
**STA. 721+23.00**  
**STRUCTURE NO. 083-0073**

	USER NAME = Denbe Herrera	DESIGNED - DH	REVISED -	<b>STATE OF ILLINOIS</b> <b>DEPARTMENT OF TRANSPORTATION</b>	<b>GENERAL PLAN AND ELEVATION</b> <b>SN 083-0073</b>		F.A.P. RTE. 332	SECTION 29B-3	COUNTY SALINE	TOTAL SHEETS 143	SHEET NO. 54
	PLOT SCALE = N/A	CHECKED - ATI	REVISED -		SCALE:	SHEET 1 OF 25 SHEETS	STA. TO STA.	ILLINOIS FED. AID PROJECT		CONTRACT NO. 78716	
License No. 184-000613	PLOT DATE = 5/3/2022 (8:20:41 AM)	DATE - 05/03/2022	REVISED -								

**EXHIBIT C**  
**BORING LOGS**

ILLINOIS DEPARTMENT OF TRANSPORTATION  
District Nine Materials

Bridge Foundation  
Boring Log

Sheet 1 of 3

FAP 332 (US 45) Over North Fork Saline River

Route: FAP 332 (US 45) Structure Number: 083-0001

Date: 5/11/2010

Section 29-B-Y

Bored By: R Moberly

County: Saline

Location: 1 mile North of Texas City

Checked By: R Graeff

Boring No 1-S	Station 739+97	Offset 10' Lt CL	Ground Surface 369.1 Ft	DEPT H	BLOWS	Qu tsf	W%	Surf Wat Eley: 339.1	DEPT H	BLOWS	Qu tsf	W%	
								Ground Water Elevation when Drilling 334.1					At Completion
Very stiff, moist, brown, Clay A7-6								Hard, damp, brown streaked grey, Clay A7-6		9	5.0B	23	
										12			
					2						4		
					6	2.6S	24				11	5.4B	23
					8						13		
					5.0	1					30.0	3	
						3	2.1B		27			7	4.0S
		4					9						
	362.1							337.1					
Stiff, moist, brown, Clay A7-6					1			Very stiff, moist, brown, Clay A7-6		4			
					2	1.2B	27			8	3.7B	19	
					3					12			
	359.6							334.6					
Medium, very moist, brown, Clay A7-6				10.0	1			Stiff, very moist, brown mottled grey, Silty Clay to Silty Clay Loam A-6	35.0	1			
					2	0.6B	31			4	1.2B	22	
					2					5			
	357.1							332.1					
Stiff, moist, grey, Clay A7-6					1			Very soft, very moist, brown, Silty Clay Loam A-6		WH			
					2	1.4B	27			1	0.2B	28	
					3					1			
	354.6												
Very stiff, moist, brown and grey, Clay A7-6				15.0	3			Very soft, very moist, grey, Silty Clay Loam A-4 with Sand seams	40.0	WH			
					6	2.4S	22			1	0.2B	19	
					8					1			
	352.1												
Hard, damp, brown streaked grey, Clay A7-6					3			Very soft, very moist, grey, Silty Clay Loam A-4 with Sand seams		WH			
					6	6.1B	18			1	0.2B	20	
					9					1			
					20.0	3							
		8	4.1B	20									
		10											
		3											
		8	4.1B	21									
		10											
	319.6												
	25.0				3				50.0	1			

Route: FAP 332 (US 45)

Date: 5/11/2010

Section: 29-B-Y

County: Saline

Boring No: 1-S  
 Station: 739+97  
 Offset: 10' Lt CL  
 Ground Surface: 369.1 Ft

DEPT H	BLOWS	Qu tsf	W%	DEPT H	BLOWS	Qu tsf	W%
314.6	2 3	0.8B	23	279.6	9 15	3.5B	24
309.6	55.0	1.5B	18	80.0	1 3 5	2.3B	28
304.6	60.0	3.5B	21	85.0	3		
294.6	65.0	1.6B	25	90.0	WH 1 1	0.6B	24
70.0	2			95.0			
294.6	4 6	1.9B	26	269.6			
75.0	3			100.0	WH		

Route: FAP 332 (US 45)

Section: 29-B-Y

County: Saline

Boring No: 1-S  
 Station: 739+97  
 Offset: 10' Lt CL  
 Ground Surface: 369.1 Ft

	DEPTH	BLOWS	Qu tsf	W%		DEPTH	BLOWS	Qu tsf	W%
Very loose, wet, grey, Sand Loam to Sandy Clay Loam A-4 with Sand seams		WH	0.2B	25	Bottom of hole = 124.7 feet				
		WH							
					Free water observed at 35.0 feet				
					Elevation referenced to BM at NE wingwall; Elev.= 370.5 feet				
	105.0				To convert "N" values to "N60" multiply by 1.25	130.0			
	259.6								
Dense, moist, blue grey, Sand Loam A-4 with pea gravel	110.0	19				135.0			
		24	2.5S	22					
		30							
	257.1								
Hard, dry, grey, Clay Shale									
	115.0	100/3"				140.0			
	120.0	100/2"				145.0			
Hard, dry, grey, Clay Shale	244.1	125.0	100/2"			150.0			

N-Std Pentr Test: 2" OD Sampler, 140# Hammer, 30" Fall (Type Fail. B-Bulge S-Shear E-Estimated P-Penetrometer)

ILLINOIS DEPARTMENT OF TRANSPORTATION  
District Nine Materials

Bridge Foundation  
Boring Log

Sheet 1 of 3

FAP 332 (US 45) Over North Fork Saline River

Route: FAP 332 (US 45) Structure Number: 083-0001

Date: 5/17/2010

Section 29-B-Y

Bored By: R Moberly

County: Saline Location: 1 mile North of Texas City

Checked By: R Graeff

Boring No 2-S	Station 737+28	Offset 11' Lt CL	Ground Surface 368.4 Ft	D E P T H	B L O W S	Qu tsf	W%	Surf Wat Elev: 339.1							
								Ground Water Elevation							
								when Drilling 330.9							
								At Completion							
								At:		Hrs:		D E P T H	B L O W S	Qu tsf	W%
Stiff, moist, brown, Clay A7-6															
												9	5.0B	24	
												11			
					1							3			
					2	1.2B	27					9	4.3B	25	
					3							10			
			5.0									30.0			
					1							2			
					1	1.1B	29					7	5.0B	24	
					2							7			
					1							3			
					1	1.1B	28					8	4.5B	23	
					2							10			
			358.4									334.4			
												35.0			
Stiff, moist, grey, Clay A7-6					1							1			
					2	1.1B	29					2	0.3B	23	
					2							3			
					1							1			
					3	1.8B	27					3	0.3B	21	
					3							5			
			353.4									328.4			
												40.0			
Very stiff, moist, brown mottled grey, Clay A7-6					3							2			
					6	2.8S	19					4	1.4S	22	
					8							4			
			350.9												
Hard, damp to moist, brown, Clay A7-6 with Silt lenses					3										
					7	5.8B	25								
					9										
			20.0									323.4			
					3							45.0			
					7	4.1B	19								
					9										
					3										
					8	4.0B	22								
					10										
			343.4									318.4			
												50.0			

N-Std Pentr Test: 2" OD Sampler, 140# Hammer, 30" Fall (Type Fail. B-Bulge S-Shear E-Estimated P-Penetrometer)

Route: FAP 332 (US 45)

Section: 29-B-Y

County: Saline

Boring No: 2-S

Station: 737+28

Offset: 11' Lt CL

Ground Surface: 368.4 Ft

	DEPT H	BLOWS	Qu tsf	W%		DEPT H	BLOWS	Qu tsf	W%
Very stiff, moist, grey, Silty Clay to Silty Clay Loam A-6		2			Stiff, moist, grey, Clay to Silty Clay A7-6		3		
		7	3.3B	19			6	1.9B	27
		10					8		
	55.0					80.0			
		8					2		
		13	3.1B	20			3	1.6B	27
		14					5		
	60.0					85.0			
		3							
		7	2.7B	25					
		11							
	303.4	65.0				278.4	90.0		
Stiff, moist to very moist, grey, Silty Clay A7-6		2			Very soft, very moist, grey, Silt Loam to Silty Clay Loam A-4		2		
		5	1.6B	26			4	0.2B	21
		7					3		
	298.4	70.0				95.0			
Stiff, moist, grey, Clay A7-6		2							
		4	1.3B	26					
		6							
	293.4	75.0				268.4	100.0		



Route: FAP 332 (US 45)

Section: 29-B-Y

County: Saline

Boring No: 2-S

Station: 737+28

Offset: 11' Lt CL

Ground Surface: 368.4 Ft

	DEPTH	BLOWS	Qu tsf	W%		DEPTH	BLOWS	Qu tsf	W%
Very soft, very moist, grey, Silty Clay Loam A-6		WH							
		1	0.2B	25					
		1							
265.4									
Hard, dry to damp, grey, Clay Shale									
	105.0					130.0			
		100/8"							
Hard, dry, grey, Clay Shale									
	110.0					135.0			
257.9		100/4"							
Bottom of hole = 110.3 feet									
Free water observed at 37.5 feet									
Elevation referenced to BM at NE wingwall; Elev.= 370.5 feet									
To convert "N" values to "N60" multiply by 1.25	115.0					140.0			
	120.0					145.0			
	125.0					150.0			

**EXHIBIT D**  
**SUBSURFACE PROFILE**

PRINTERMOD2 11X17 19-1143.02 US 45 OVER N FORK SALINE RIVER.GPJ IL\_DOT.GDT 8/31/20

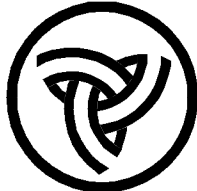
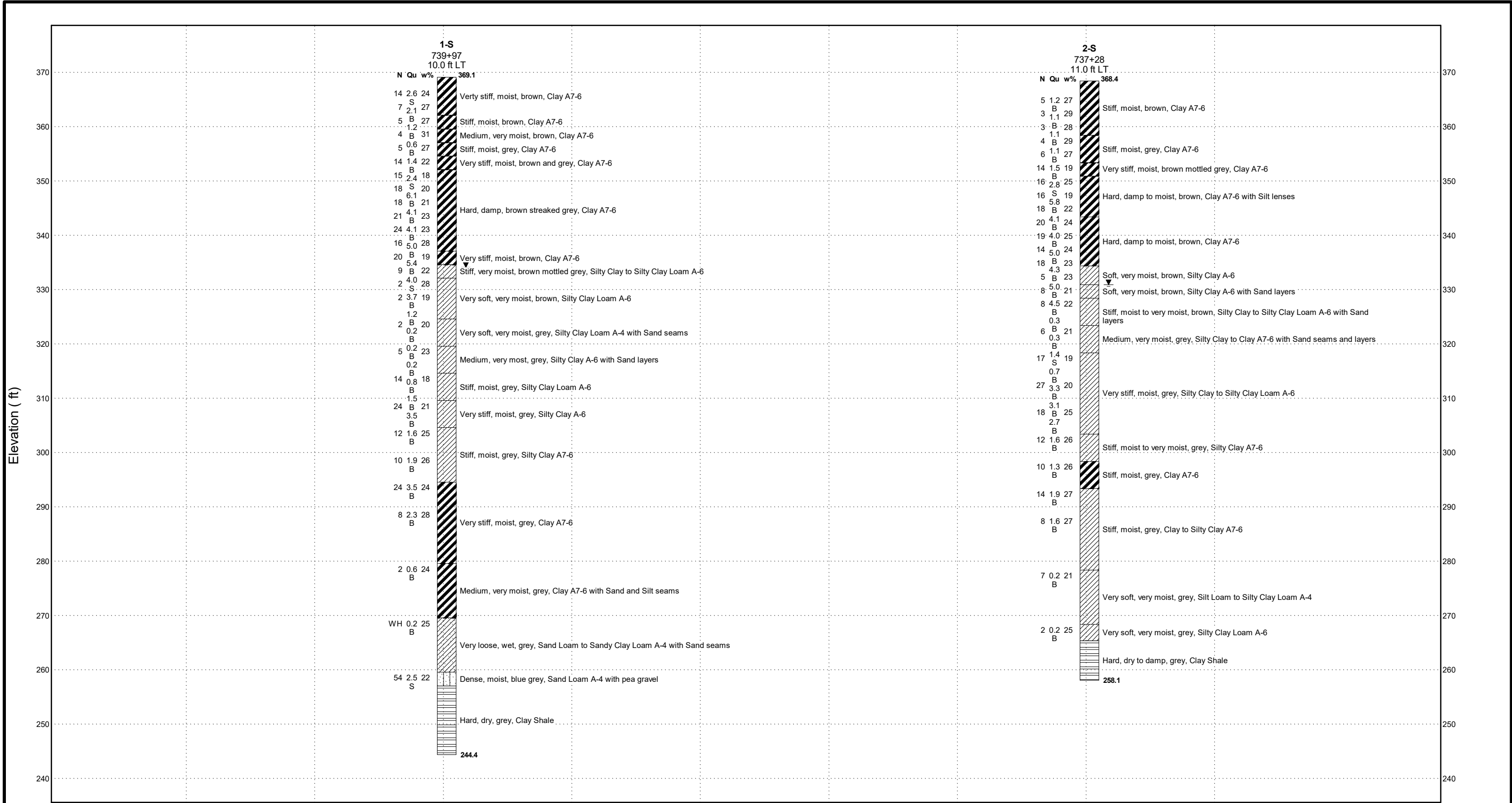

**Illinois Department of Transportation**  
Division of Highways

NOT TO HORIZONTAL SCALE

**SUBSURFACE DATA PROFILE**

Route: FAP 332 (US 45)  
Section: 29-B-Y  
County: Saline

**EXHIBIT E**  
**SLOPE/W SLOPE STABILITY ANALYSIS**

**US 45 over N Fork Saline River  
 SN 083-0001 North Abutment - Boring 1-S  
 End-of-construction (Undrained Condition)**

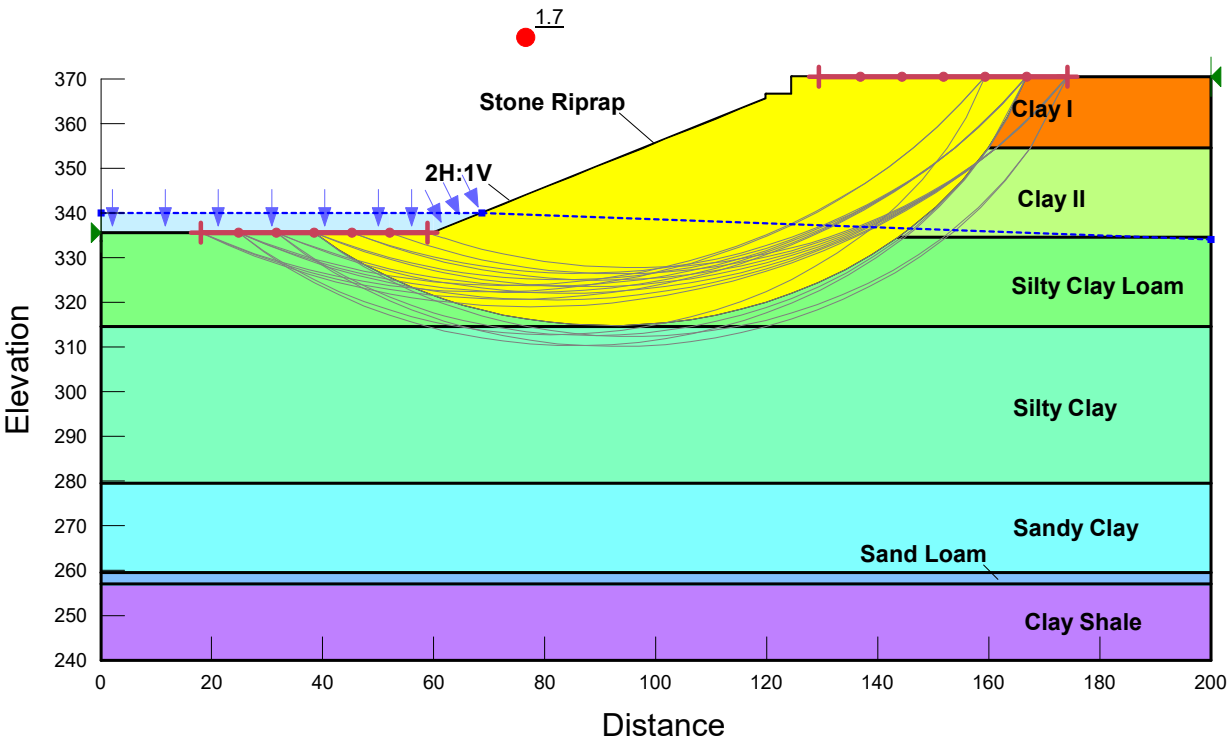

**Name: Clay I**  
 Unit Weight: 125 pcf  
 Cohesion': 1,600 psf  
 Phi': 0 °

**Name: Clay II**  
 Unit Weight: 125 pcf  
 Cohesion': 3,900 psf  
 Phi': 0 °

**Name: Silty Clay Loam**  
 Unit Weight: 110 pcf  
 Cohesion': 500 psf  
 Phi': 0 °

**Name: Silty Clay**  
 Unit Weight: 120 pcf  
 Cohesion': 2,400 psf  
 Phi': 0 °

**Name: Sandy Clay**  
 Unit Weight: 115 pcf  
 Cohesion': 400 psf  
 Phi': 0 °

**Name: Sand Loam**  
 Unit Weight: 110 pcf  
 Cohesion': 2,500 psf  
 Phi': 34 °

**Name: Clay Shale**  
 Unit Weight: 125 pcf  
 Cohesion': 5,000 psf  
 Phi': 12 °

**Name: Concrete**  
 Unit Weight: 150 pcf  
 Cohesion': 25,000 psf  
 Phi': 45 °

**Name: Rip Rap**  
 Unit Weight: 145 pcf  
 Cohesion': 0 psf  
 Phi': 42 °

**US 45 over N Fork Saline River  
 SN 083-0001 North Abutment - Boring 1-S  
 Long Term Analysis (Drained Condition)**

Phi': 26 °

Name: Clay II  
 Unit Weight: 125 pcf  
 Cohesion': 150 psf  
 Phi': 26 °

Name: Silty Clay Loam  
 Unit Weight: 110 pcf  
 Cohesion': 150 psf  
 Phi': 28 °

Name: Silty Clay  
 Unit Weight: 120 pcf  
 Cohesion': 100 psf  
 Phi': 28 °

Name: Sandy Clay  
 Unit Weight: 115 pcf  
 Cohesion': 50 psf  
 Phi': 28 °

Name: Sand Loam  
 Unit Weight: 110 pcf  
 Cohesion': 200 psf  
 Phi': 34 °

Name: Clay Shale  
 Unit Weight: 125 pcf  
 Cohesion': 5,000 psf  
 Phi': 12 °

Name: Concrete  
 Unit Weight: 150 pcf  
 Cohesion': 25,000 psf  
 Phi': 45 °

Name: Rip Rap  
 Unit Weight: 145 pcf  
 Cohesion': 0 psf  
 Phi': 42 °

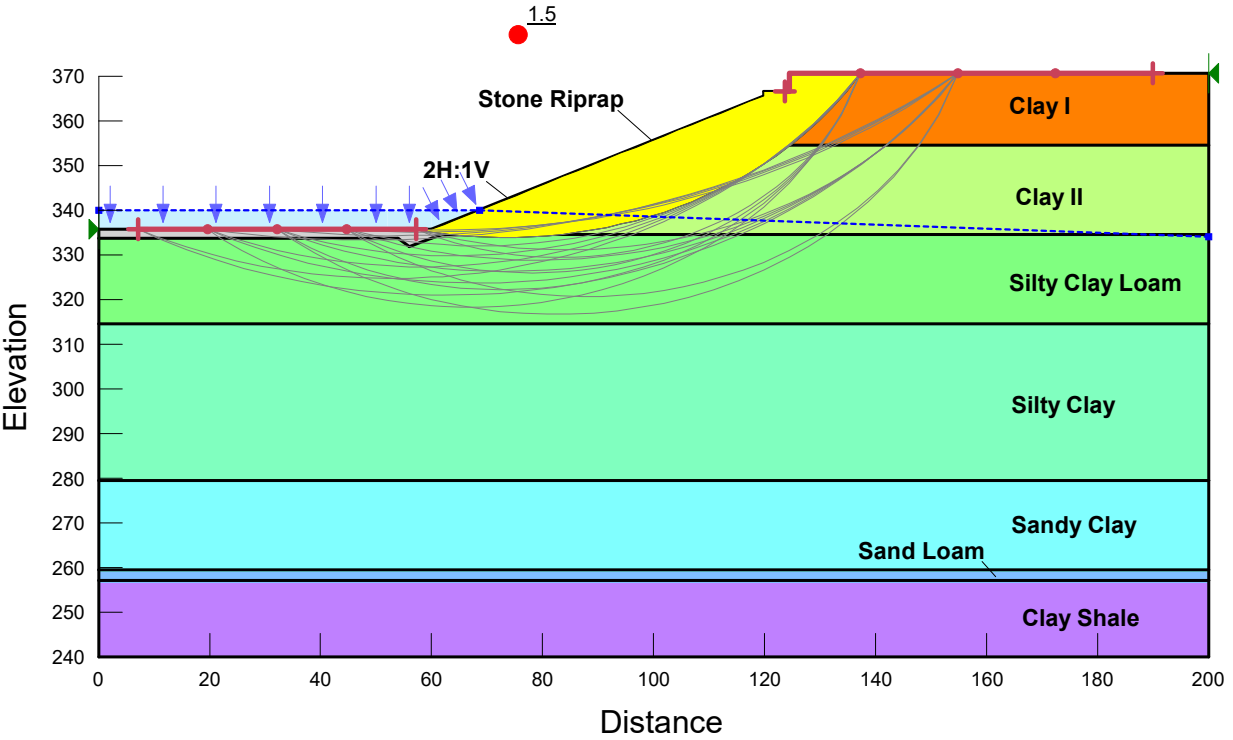

Distance

Elevation

**US 45 over N Fork Saline River**  
**SN 083-0001 North Abutment - Boring 1-S**  
**Long Term Analysis (Drained Condition)**  
**Seismic PGA 0.292g**  
**8' Pile Spacing (Abutment and Pier)**

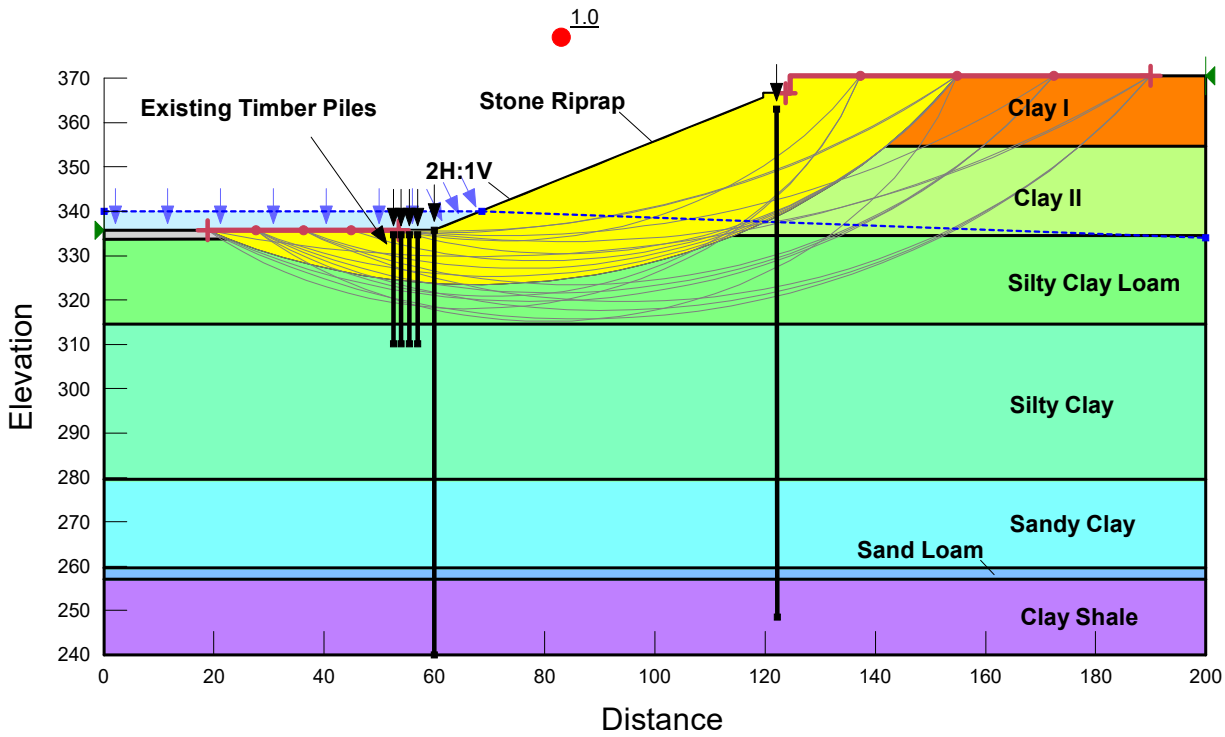

**Name: Clay I**  
**Unit Weight: 125 pcf**  
**Cohesion': 200 psf**  
**Phi': 26 °**

**Name: Clay II**  
**Unit Weight: 125 pcf**  
**Cohesion': 150 psf**  
**Phi': 26 °**

**Name: Silty Clay Loam**  
**Unit Weight: 110 pcf**  
**Cohesion': 150 psf**  
**Phi': 28 °**

**Name: Silty Clay**  
**Unit Weight: 120 pcf**  
**Cohesion': 100 psf**  
**Phi': 28 °**

**Name: Sandy Clay**  
**Unit Weight: 115 pcf**  
**Cohesion': 50 psf**  
**Phi': 28 °**

**Name: Sand Loam**  
**Unit Weight: 110 pcf**  
**Cohesion': 200 psf**  
**Phi': 34 °**

**Name: Clay Shale**  
**Unit Weight: 125 pcf**  
**Cohesion': 5,000 psf**  
**Phi': 12 °**

**Name: Concrete**  
**Unit Weight: 150 pcf**

**Name: Rip Rap**  
**Unit Weight: 145 pcf**  
**Phi': 42 °**

**US 45 over N Fork Saline River  
SN 083-0001 South Abutment - Boring 2-S  
End-of-construction (Undrained Condition)**

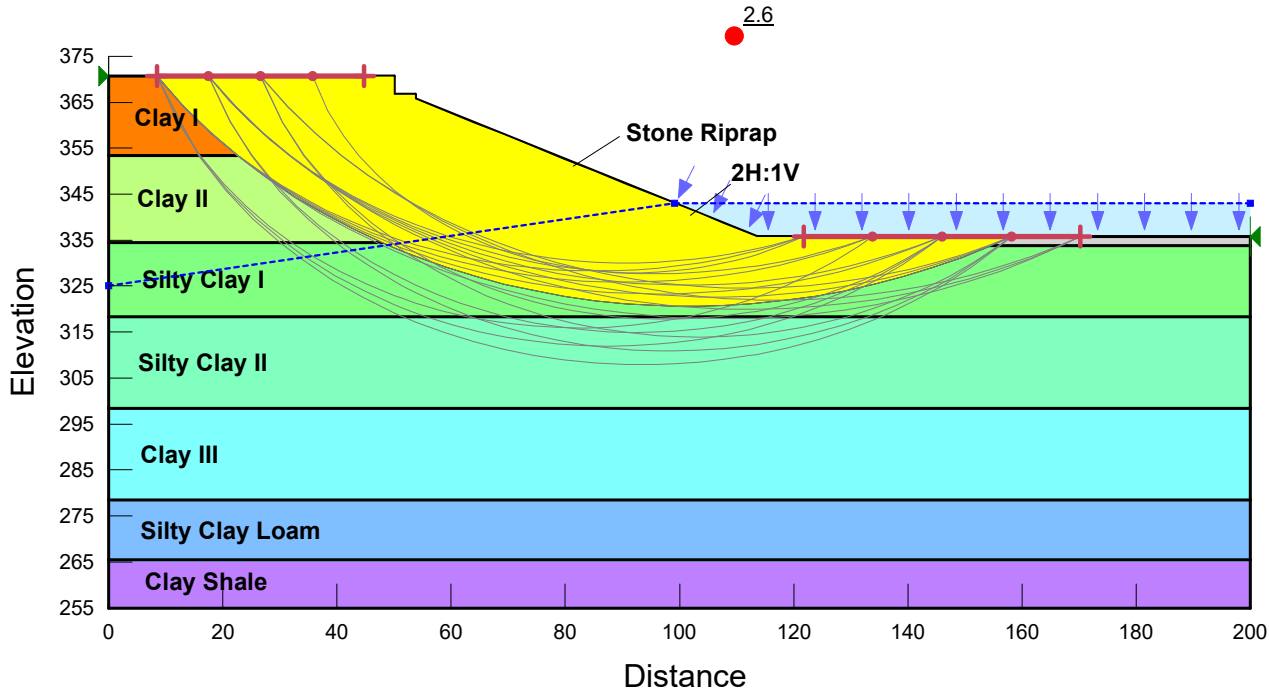

**Unit Weight:** 125 pcf  
**Cohesion:** 1,300 psf  
**Phi:** 0 °

**Name:** Clay II  
**Unit Weight:** 125 pcf  
**Cohesion:** 4,400 psf  
**Phi:** 0 °

**Name:** Silty Clay I  
**Unit Weight:** 120 pcf  
**Cohesion:** 700 psf  
**Phi:** 0 °

**Name:** Silty Clay II  
**Unit Weight:** 120 pcf  
**Cohesion:** 2,700 psf  
**Phi:** 0 °

**Name:** Clay III  
**Unit Weight:** 125 pcf  
**Cohesion:** 1,600 psf  
**Phi:** 0 °

**Name:** Silty Clay Loam  
**Unit Weight:** 110 pcf  
**Cohesion:** 200 psf  
**Phi:** 0 °

**Name:** Clay Shale  
**Unit Weight:** 125 pcf  
**Cohesion:** 5,000 psf  
**Phi:** 12 °

**Name:** Concrete  
**Unit Weight:** 150 pcf  
**Cohesion:** 25,000 psf  
**Phi:** 45 °

**Name:** Rip Rap  
**Unit Weight:** 145 pcf  
**Cohesion:** 0 psf  
**Phi:** 42 °



**US 45 over N Fork Saline River  
SN 083-0001 South Abutment - Boring 2-S  
Long Term Analysis (Drained Condition)**

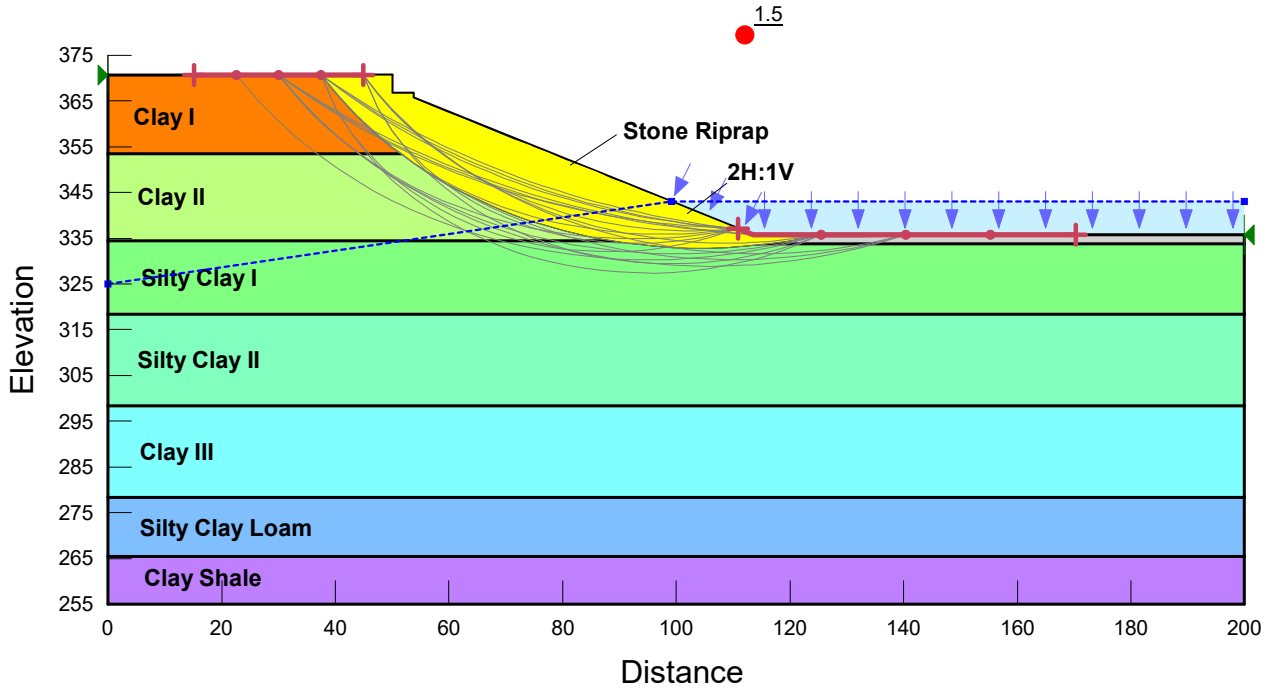

**Name:** Clay I  
**Unit Weight:** 125 pcf  
**Cohesion:** 200 psf  
**Phi:** 26 °

**Name:** Clay II  
**Unit Weight:** 125 pcf  
**Cohesion:** 150 psf  
**Phi:** 26 °

**Name:** Silty Clay I  
**Unit Weight:** 120 pcf  
**Cohesion:** 100 psf  
**Phi:** 28 °

**Name:** Silty Clay II  
**Unit Weight:** 120 pcf  
**Cohesion:** 100 psf  
**Phi:** 28 °

**Name:** Clay III  
**Unit Weight:** 125 pcf  
**Cohesion:** 100 psf  
**Phi:** 26 °

**Name:** Silty Clay Loam  
**Unit Weight:** 110 pcf  
**Cohesion:** 50 psf  
**Phi:** 28 °

**Name:** Clay Shale  
**Unit Weight:** 125 pcf  
**Cohesion:** 5,000 psf  
**Phi:** 12 °

**Name:** Concrete  
**Unit Weight:** 150 pcf  
**Cohesion:** 25,000 psf  
**Phi:** 45 °

**Name:** Rip Rap  
**Unit Weight:** 145 pcf  
**Cohesion:** 0 psf  
**Phi:** 42 °

**US 45 over N Fork Saline River**  
**SN 083-0001 South Abutment - Boring 2-S**  
**Long Term Analysis (Drained Condition)**  
**Seismic PGA 0.292g**  
**8' Pile Spacing (Abutment and Pier)**

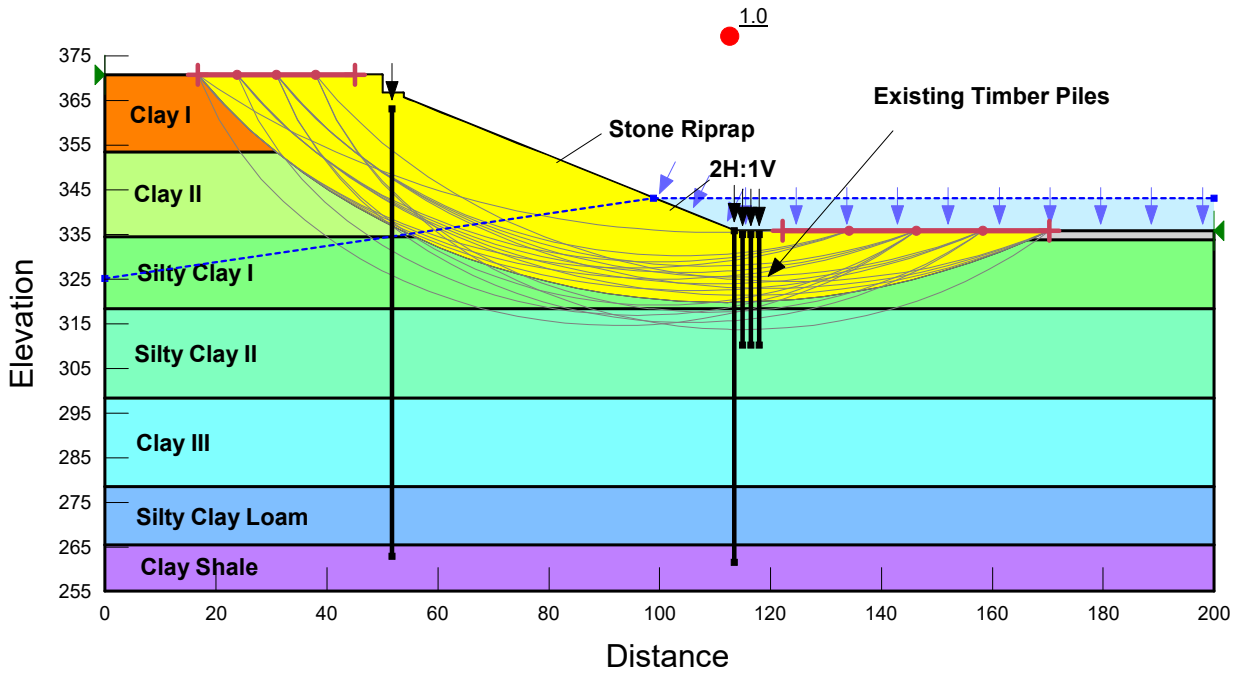

**Name: Clay I**  
**Unit Weight: 125 pcf**  
**Cohesion': 200 psf**  
**Phi': 26 °**

**Name: Clay II**  
**Unit Weight: 125 pcf**  
**Cohesion': 150 psf**  
**Phi': 26 °**

**Name: Silty Clay I**  
**Unit Weight: 120 pcf**  
**Cohesion': 100 psf**  
**Phi': 28 °**

**Name: Silty Clay II**  
**Unit Weight: 120 pcf**  
**Cohesion': 100 psf**  
**Phi': 26 °**

**Name: Clay III**  
**Unit Weight: 125 pcf**  
**Cohesion': 100 psf**  
**Phi': 26 °**

**Name: Silty Clay Loam**  
**Unit Weight: 110 pcf**  
**Cohesion': 50 psf**  
**Phi': 28 °**

**Name: Clay Shale Unit**  
**Weight: 125 pcf**  
**Cohesion': 5,000 psf**  
**Phi': 12 °**

**Name: Concrete**  
**Unit Weight: 150 pcf**

**Name: Rip Rap**  
**Unit Weight: 145 pcf**  
**Phi': 42 °**

**EXHIBIT F**  
**LIQUEFACTION ANALYSES RESULTS**

REFERENCE BORING NUMBER ===== 1-S N. Abut  
 ELEVATION OF BORING GROUND SURFACE ===== 369.10 FT.  
 DEPTH TO GROUNDWATER - DURING DRILLING ===== 35.00 FT. (Below Boring Ground Surface)  
 DEPTH TO GROUNDWATER - DURING EARTHQUAKE ===== 35.00 FT. (Below Finished Grade Cut or Fill Surface)  
 PEAK HORIZ. GROUND SURFACE ACCELERATION COEFFICIENT (As) ===== 0.201  
 EARTHQUAKE MOMENT MAGNITUDE ===== 7.5  
 FINISHED GRADE FILL OR CUT FROM BORING SURFACE ===== 0.00 FT.  
 HAMMER EFFICIENCY ===== 73 %  
 BOREHOLE DIAMETER ===== 8 IN.  
 SAMPLING METHOD ===== Sampler w/out Liners

**EQ MAGNITUDE SCALING FACTOR**  
 (MSF) = 1.000

**AVG. SHEAR WAVE VELOCITY (top 40')**  
 $V_{s,40'}$  = 483 FT./SEC.

**PGA CALCULATOR**  
 Earthquake Moment Magnitude = 7.5  
 Source-To-Site Distance, R (km) = 128  
 Ground Motion Prediction Equations = NMSZ  
 PGA = 0.118

ELEV. OF SAMPLE (FT.)	BORING DATA							CONDITIONS DURING DRILLING					CONDITIONS DURING EARTHQUAKE					SOIL MASS PART. FACTOR (r <sub>d</sub> )	EQ INDUCED CSR	FACTOR OF SAFETY * CRR/CSR
	BORING SAMPLE DEPTH (FT.)	SPT N VALUE (BLOWS)	UNCONF. COMPR. STR., Q <sub>u</sub> (TSF.)	% FINES < #200 (%)	PLAST. INDEX PI	LIQUID LIMIT LL	MOIST. CONTENT w <sub>c</sub> (%)	EFFECTIVE UNIT WT. (KCF.)	VERT. STRESS (KSF.)	CORR. SPT N VALUE (N <sub>1</sub> ) <sub>60</sub>	EQUIV. CLN. SAND SPT N VALUE (N <sub>1</sub> ) <sub>60cs</sub>	CRR RESIST. MAG 7.5 CRR <sub>7.5</sub>	EFFECTIVE UNIT WT. (KCF.)	VERT. STRESS (KSF.)	TOTAL STRESS (KSF.)	OVER-BURDEN CORR. FACT. (Ks)	CORR. RESIST. CRR <sub>7.5</sub> CRR			
367.1	2	14	2.6		12	14	24	0.133	0.266	30.051	30.051	0.471	0.133	0.266	0.266	1.500	0.707	0.988	0.129	N.L. (1)
364.6	4.5	7	2.1				27	0.130	0.591	12.066	12.066	0.132	0.130	0.591	0.591	1.366	0.180	0.971	0.127	N.L. (1)
362.1	7	5	1.2				27	0.124	0.901	7.814	7.814	0.094	0.124	0.901	0.901	1.205	0.114	0.950	0.124	N.L. (1)
359.6	9.5	4	0.6				31	0.116	1.191	6.183	6.183	0.081	0.116	1.191	1.191	1.127	0.091	0.926	0.121	N.L. (1)
357.1	12	5	1.4				27	0.125	1.504	7.555	7.555	0.092	0.125	1.504	1.504	1.077	0.099	0.899	0.117	N.L. (1)
354.6	14.5	14	2.4				22	0.132	1.834	21.280	21.280	0.232	0.132	1.834	1.834	1.045	0.242	0.868	0.113	N.L. (1)
352.1	17	15	6.1				18	0.144	2.194	21.650	21.650	0.237	0.144	2.194	2.194	0.990	0.235	0.835	0.109	N.L. (1)
349.6	19.5	18	4.1				20	0.139	2.541	25.072	25.072	0.293	0.139	2.541	2.541	0.943	0.276	0.800	0.104	N.L. (1)
347.1	22	18	4.1				21	0.139	2.889	23.587	23.587	0.266	0.139	2.889	2.889	0.907	0.242	0.764	0.100	N.L. (1)
344.6	24.5	21	5				23	0.142	3.244	26.423	26.423	0.323	0.142	3.244	3.244	0.868	0.280	0.730	0.095	N.L. (1)
342.1	27	24	5.4				23	0.143	3.601	28.965	28.965	0.409	0.143	3.601	3.601	0.831	0.339	0.697	0.091	N.L. (1)
339.6	29.5	16	4				28	0.139	3.949	17.332	17.332	0.184	0.139	3.949	3.949	0.842	0.155	0.666	0.087	N.L. (1)
337.1	32	20	3.7				19	0.138	4.294	21.059	21.059	0.229	0.138	4.294	4.294	0.809	0.185	0.639	0.084	N.L. (1)
334.6	34.5	9	1.2				22	0.124	4.604	8.807	8.807	0.103	0.124	4.604	4.604	0.841	0.086	0.616	0.080	N.L. (1)
332.1	37	2	0.2		12	12	22	0.042	4.709	1.935	1.935	0.053	0.042	4.709	4.833	0.852	0.045	0.595	0.080	N.L. (2)
329.6	39.5	2	0.2		12	19	19	0.042	4.814	1.913	1.913	0.052	0.042	4.814	5.094	0.849	0.045	0.579	0.080	N.L. (2)
324.6	44.5	2	0.2		12	10	20	0.042	5.024	1.871	1.871	0.052	0.042	5.024	5.616	0.842	0.044	0.554	0.081	N.L. (2)
319.6	49.5	5	0.8		12	13	23	0.057	5.309	4.529	4.529	0.069	0.057	5.309	6.213	0.832	0.057	0.538	0.082	N.L. (2)
314.6	54.5	14	1.5		12	8	18	0.064	5.629	12.230	12.230	0.133	0.064	5.629	6.845	0.787	0.105	0.527	0.084	N.L. (2)
309.6	59.5	24	3.5		12	11	21	0.074	5.999	20.666	20.666	0.224	0.074	5.999	7.527	0.733	0.164	0.521	0.085	N.L. (2)
304.6	64.5	12	1.6		12	15	25	0.065	6.324	9.688	9.688	0.110	0.065	6.324	8.164	0.778	0.086	0.518	0.087	N.L. (2)
299.6	69.5	10	1.9		12	16	26	0.067	6.659	7.781	7.781	0.094	0.067	6.659	8.811	0.780	0.073	0.506	0.087	N.L. (2)
294.6	74.5	24	3.5		12	14	24	0.074	7.029	18.237	18.237	0.194	0.074	7.029	9.493	0.712	0.139	0.499	0.088	N.L. (2)
289.6	79.5	8	2.3		12	18	28	0.069	7.374	5.788	5.788	0.078	0.069	7.374	10.150	0.774	0.060	0.492	0.088	N.L. (2)
279.6	89.5	2	0.6		12	14	24	0.053	7.904	1.374	1.374	0.050	0.053	7.904	11.304	0.769	0.039	0.478	0.089	N.L. (2)
269.6	99.5	1	0.2		12	15	25	0.042	8.324	0.649	0.649	0.049	0.042	8.324	12.348	0.761	0.037	0.464	0.090	N.L. (2)
259.6	109.5	54	2.5				22	0.070	9.024	31.046	31.046	0.564	0.070	9.024	13.672	0.591	0.333	0.450	0.089	N.L. (3)

\* FACTOR OF SAFETY DESCRIPTIONS

- N.L. (1) = NOT LIQUEFIABLE, ABOVE EQ GROUND WATER ELEVATION
- N.L. (2) = NOT LIQUEFIABLE, PI ≥ 12 OR w<sub>c</sub>/LL ≤ 0.85
- N.L. (3) = NOT LIQUEFIABLE, (N<sub>1</sub>)<sub>60</sub> > 25
- (C) = CONTRACTIVE SOIL TYPES
- (D) = DILATIVE SOIL TYPES

REFERENCE BORING NUMBER ===== 2-S S Abut  
 ELEVATION OF BORING GROUND SURFACE ===== 368.40 FT.  
 DEPTH TO GROUNDWATER - DURING DRILLING ===== 37.50 FT. (Below Boring Ground Surface)  
 DEPTH TO GROUNDWATER - DURING EARTHQUAKE ===== 37.50 FT. (Below Finished Grade Cut or Fill Surface)  
 PEAK HORIZ. GROUND SURFACE ACCELERATION COEFFICIENT (As) ===== 0.201  
 EARTHQUAKE MOMENT MAGNITUDE ===== 7.5  
 FINISHED GRADE FILL OR CUT FROM BORING SURFACE ===== 0.00 FT.  
 HAMMER EFFICIENCY===== 73 %  
 BOREHOLE DIAMETER===== 8 IN.  
 SAMPLING METHOD===== Sampler w/out Liners

**EQ MAGNITUDE SCALING FACTOR**  
 (MSF) = 1.000

**AVG. SHEAR WAVE VELOCITY (top 40')**  
 $V_{s,40'}$  = 496 FT./SEC.

**PGA CALCULATOR**  
 Earthquake Moment Magnitude = 7.5  
 Source-To-Site Distance, R (km) = 128  
 Ground Motion Prediction Equations = NMSZ  
 PGA = 0.118

ELEV. OF SAMPLE (FT.)	BORING DATA							CONDITIONS DURING DRILLING					CONDITIONS DURING EARTHQUAKE				CORR. RESIST. CRR <sub>7.5</sub> CRR	SOIL MASS PART. FACTOR (r <sub>d</sub> )	EQ INDUCED CSR	FACTOR OF SAFETY * CRR/CSR
	BORING SAMPLE DEPTH (FT.)	SPT N VALUE (BLOWS)	UNCONF. COMPR. STR., Q <sub>u</sub> (TSF.)	% FINES < #200 (%)	PLAST. INDEX PI	LIQUID LIMIT LL	MOIST. CONTENT w <sub>c</sub> (%)	EFFECTIVE UNIT WT. (KCF.)	CORR. SPT N VALUE (N <sub>1</sub> ) <sub>60</sub>	EQUIV. CLN. SAND SPT N VALUE (N <sub>1</sub> ) <sub>60cs</sub>	CRR RESIST. MAG 7.5 CRR <sub>7.5</sub>	EFFECTIVE UNIT WT. (KCF.)	VERT. STRESS (KSF.)	TOTAL VERT. STRESS (KSF.)	OVER-BURDEN CORR. FACT. (Ks)					
365.9	2.5	5	1.2				0.124	9.432	9.432	0.108	0.124	0.310	0.310	1.500	0.162	0.987	0.129	N.L. (1)		
363.4	5	3	1.1				0.123	5.109	5.109	0.073	0.123	0.618	0.618	1.281	0.093	0.971	0.127	N.L. (1)		
360.9	7.5	3	1.1				0.123	4.686	4.686	0.070	0.123	0.925	0.925	1.180	0.082	0.952	0.124	N.L. (1)		
358.4	10	4	1.1				0.123	6.196	6.196	0.081	0.123	1.233	1.233	1.119	0.091	0.929	0.121	N.L. (1)		
355.9	12.5	6	1.8				0.128	9.041	9.041	0.105	0.128	1.553	1.553	1.073	0.112	0.903	0.118	N.L. (1)		
353.4	15	14	2.8				0.134	21.125	21.125	0.230	0.134	1.888	1.888	1.036	0.238	0.874	0.114	N.L. (1)		
350.9	17.5	16	5.8				0.144	23.100	23.100	0.259	0.144	2.248	2.248	0.982	0.254	0.842	0.110	N.L. (1)		
348.4	20	16	4.1				0.139	21.746	21.746	0.238	0.139	2.595	2.595	0.940	0.224	0.808	0.106	N.L. (1)		
345.9	22.5	18	4				0.139	23.378	23.378	0.263	0.139	2.943	2.943	0.902	0.237	0.774	0.101	N.L. (1)		
343.4	25	20	5				0.142	24.769	24.769	0.287	0.142	3.298	3.298	0.867	0.249	0.740	0.097	N.L. (1)		
340.9	27.5	19	4.3				0.140	22.034	22.034	0.242	0.140	3.648	3.648	0.847	0.205	0.708	0.092	N.L. (1)		
338.4	30	14	5				0.142	14.852	14.852	0.159	0.142	4.003	4.003	0.847	0.134	0.678	0.089	N.L. (1)		
335.9	32.5	18	4.5				0.140	18.562	18.562	0.198	0.140	4.353	4.353	0.815	0.161	0.651	0.085	N.L. (1)		
333.4	35	5	0.3				0.108	4.883	4.883	0.071	0.108	4.623	4.623	0.856	0.061	0.627	0.082	N.L. (1)		
330.9	37.5	8	0.3				0.108	7.554	7.554	0.092	0.108	4.893	4.893	0.835	0.077	0.607	0.079	N.L. (1)		
328.4	40	8	1.4		12	12	0.063	7.420	7.420	0.091	0.063	5.050	5.206	0.829	0.076	0.590	0.080	N.L. (2)		
323.4	45	6	0.7		12	11	0.055	5.400	5.400	0.075	0.055	5.325	5.793	0.830	0.062	0.565	0.080	N.L. (2)		
318.4	50	17	3.3		12	9	0.074	14.684	14.684	0.157	0.074	5.695	6.475	0.773	0.121	0.549	0.081	N.L. (2)		
313.4	55	27	3.1		12	10	0.073	23.353	23.353	0.263	0.073	6.060	7.152	0.718	0.189	0.538	0.083	N.L. (2)		
308.4	60	18	2.7		12	15	0.071	14.375	14.375	0.154	0.071	6.415	7.819	0.751	0.116	0.532	0.085	N.L. (2)		
303.4	65	12	1.6		12	16	0.065	9.254	9.254	0.107	0.065	6.740	8.456	0.769	0.082	0.522	0.086	N.L. (2)		
298.4	70	10	1.3		12	16	0.062	7.463	7.463	0.091	0.062	7.050	9.078	0.772	0.071	0.515	0.087	N.L. (2)		
293.4	75	14	1.9		12	17	0.067	10.102	10.102	0.114	0.067	7.385	9.725	0.748	0.085	0.508	0.087	N.L. (2)		
288.4	80	8	1.6		12	17	0.065	5.599	5.599	0.077	0.065	7.710	10.362	0.768	0.059	0.501	0.088	N.L. (2)		
278.4	90	7	0.2		12	11	0.042	4.708	4.708	0.070	0.042	8.130	11.406	0.764	0.053	0.487	0.089	N.L. (2)		
268.4	100	2	0.2		12	15	0.042	1.268	1.268	0.050	0.042	8.550	12.450	0.757	0.038	0.473	0.090	N.L. (2)		

\* FACTOR OF SAFETY DESCRIPTIONS

- N.L. (1) = NOT LIQUEFIABLE, ABOVE EQ GROUND WATER ELEVATION
- N.L. (2) = NOT LIQUEFIABLE, PI ≥ 12 OR w<sub>c</sub>/LL ≤ 0.85
- N.L. (3) = NOT LIQUEFIABLE, (N<sub>1</sub>)<sub>60</sub> > 25
- (C) = CONTRACTIVE SOIL TYPES
- (D) = DILATIVE SOIL TYPES

**EXHIBIT G**  
**PILE LENGTH/PILE TYPE**

SUBSTRUCTURE=====North Abut.  
 REFERENCE BORING=====1-S  
 LRFD or ASD or SEISMIC=====LRFD  
 PILE CUTOFF ELEV.=====365.31 ft  
 GROUND SURFACE ELEV. AGAINST PILE DURING DRIVING=363.31 ft  
 GEOTECHNICAL LOSS TYPE (None, Scour, Liquef., DD)=====Scour  
 BOTTOM ELEV. OF SCOUR, LIQUEF., or DD=====363.31 ft  
 TOP ELEV. OF LIQUEF. (so layers above apply DD)=====ft

**MAX. REQUIRED BEARING & RESISTANCE for Selected Pile, Soil Profile, & Losses**

Maximum Nominal Req'd Bearing of Pile	Maximum Nominal Req'd Bearing of Boring	Maximum Factored Resistance Available in Boring	Maximum Pile Driveable Length in Boring
<b>335 KIPS</b>	<b>327 KIPS</b>	<b>180 KIPS</b>	<b>86 FT.</b>

TOTAL FACTORED SUBSTRUCTURE LOAD=====1100 kips  
 TOTAL LENGTH OF SUBSTRUCTURE (along skew)=====42.83 ft  
 NUMBER OF ROWS OF PILES PER SUBSTRUCTURE=====1  
 Approx. Factored Loading Applied per pile at 8 ft. Cts=====205.46 KIPS  
 Approx. Factored Loading Applied per pile at 3 ft. Cts=====77.05 KIPS

PILE TYPE AND SIZE=====Steel HP 10 X 42  
 Plugged Pile Perimeter=====3.300 FT. Unplugged Pile Perimeter=====4.858 FT.  
 Plugged Pile End Bearing Area=====0.680 SQFT. Unplugged Pile End Bearing Area=====0.086 SQFT.

BOT. OF LAYER ELEV. (FT.)	LAYER THICK. (FT.)	UNCONF. COMPR. STRENGTH (TSF.)	S.P.T. N VALUE (BLOWS)	GRANULAR OR ROCK LAYER DESCRIPTION	NOMINAL PLUGGED			NOMINAL UNPLUG'D			NOMINAL REQ'D BEARING (KIPS)	FACTORED GEOTECH. LOSS FROM SCOUR or DD (KIPS)	FACTORED GEOTECH. LOSS LOAD FROM DD (KIPS)	FACTORED RESISTANCE AVAILABLE (KIPS)	ESTIMATED PILE LENGTH (FT.)
					SIDE RESIST. (KIPS)	END BRG. RESIST. (KIPS)	TOTAL RESIST. (KIPS)	SIDE RESIST. (KIPS)	END BRG. RESIST. (KIPS)	TOTAL RESIST. (KIPS)					
361.91	1.40	2.10			5.5		17.0	8.2		9.6	10	0	0	5	3
359.41	2.50	1.20			6.8	11.4	18.0	10.0	1.4	18.8	18	0	0	10	6
356.91	2.50	0.60			3.8	5.7	29.4	5.6	0.7	25.4	25	0	0	14	8
354.41	2.50	1.40			7.6	13.3	46.5	11.1	1.7	37.7	38	0	0	21	11
351.91	2.50	2.40			10.8	22.9	92.6	15.9	2.9	58.1	58	0	0	32	13
349.41	2.50	6.10	15		17.1	58.2	90.7	25.2	7.4	80.9	81	0	0	45	16
346.91	2.50	4.10	18		15.9	39.1	106.7	23.5	4.9	104.4	104	0	0	57	18
344.41	2.50	4.10	18		15.9	39.1	131.2	23.5	4.9	129.0	129	0	0	71	21
341.91	2.50	5.00	21		17.1	47.7	152.1	25.2	6.0	154.7	152	0	0	84	23
339.41	2.50	5.40	24		17.1	51.5	155.9	25.2	6.5	178.3	156	0	0	86	26
336.91	2.50	4.00	16		15.6	38.1	168.7	23.0	4.8	200.9	169	0	0	93	28
334.41	2.50	3.70	20		14.7	35.3	159.6	21.7	4.5	219.6	160	0	0	88	31
331.91	2.50	1.20			6.8	11.4	156.9	10.0	1.4	228.4	157	0	0	86	33
329.41	2.50	0.20			1.4	1.9	158.2	2.0	0.2	230.3	158	0	0	87	36
324.41	5.00	0.20			2.7	1.9	160.9	4.0	0.2	234.3	161	0	0	89	41
319.41	5.00	0.20			2.7	1.9	169.3	4.0	0.2	239.1	169	0	0	93	46
314.41	5.00	0.80			9.7	7.6	185.8	14.3	1.0	254.2	186	0	0	102	51
309.41	5.00	1.50			15.9	14.3	220.7	23.4	1.8	280.0	221	0	0	121	56
304.41	5.00	3.50	24		28.3	33.4	230.9	41.6	4.2	319.3	231	0	0	127	61
299.41	5.00	1.60			16.6	15.3	250.3	24.4	1.9	344.1	250	0	0	138	66
294.41	5.00	1.90			18.6	18.1	284.1	27.4	2.3	373.4	284	0	0	156	71
289.41	5.00	3.50	24		28.3	33.4	301.0	41.6	4.2	413.6	301	0	0	166	76
279.41	10.00	2.30			42.0	21.9	326.8	61.9	2.8	473.4	327	0	0	180	86
269.41	10.00	0.60			15.2	5.7	338.1	22.3	0.7	495.2	338	0	0	186	96
259.41	10.00	0.20			5.4	1.9	365.5	8.0	0.2	506.0	365	0	0	204	106
256.91	2.50	2.50			11.1	23.8	437.5	16.4	3.0	530.1	438	0	0	241	108
255.91	1.00			Shale	41.1	84.8	478.6	60.5	10.7	590.6	479	0	0	263	109.4
254.91	1.00			Shale	41.1	84.8	519.7	60.5	10.7	651.1	520	0	0	286	110.4
253.91	1.00			Shale	41.1	84.8	560.8	60.5	10.7	711.6	561	0	0	308	111.4
252.91	1.00			Shale	41.1	84.8	601.9	60.5	10.7	772.2	602	0	0	331	112.4
251.91	1.00			Shale	41.1	84.8	643.1	60.5	10.7	832.7	643	0	0	354	113.4
250.91	1.00			Shale	41.1	84.8	684.2	60.5	10.7	893.2	684	0	0	376	114.4
249.91	1.00			Shale	41.1	84.8	725.3	60.5	10.7	953.7	725	0	0	399	115.4
248.91	1.00			Shale	41.1	84.8	766.4	60.5	10.7	1014.2	766	0	0	422	116.4
247.91	1.00			Shale	41.1	84.8	807.5	60.5	10.7	1074.8	807	0	0	444	117.4
246.91	1.00			Shale	41.1	84.8	848.6	60.5	10.7	1135.3	849	0	0	467	118.4
245.91	1.00			Shale	41.1	84.8	889.7	60.5	10.7	1195.8	890	0	0	489	119.4
244.91	1.00			Shale		84.8			10.7						

SUBSTRUCTURE===== Pier 1  
 REFERENCE BORING===== 2-S  
 LRFD or ASD or SEISMIC===== LRFD  
 PILE CUTOFF ELEV.===== 335.50 ft  
 GROUND SURFACE ELEV. AGAINST PILE DURING DRIVING = 333.50 ft  
 GEOTECHNICAL LOSS TYPE (None, Scour, Liquef., DD)===== Scour  
 BOTTOM ELEV. OF SCOUR, LIQUEF., or DD===== 318.75 ft  
 TOP ELEV. OF LIQUEF. (so layers above apply DD)===== 0.00 ft

**MAX. REQUIRED BEARING & RESISTANCE for Selected Pile, Soil Profile, & Losses**

Maximum Nominal Req'd Bearing of Pile	Maximum Nominal Req'd Bearing of Boring	Maximum Factored Resistance Available in Boring	Maximum Pile Driveable Length in Boring
<b>335 KIPS</b>	<b>335 KIPS</b>	<b>174 KIPS</b>	<b>72 FT.</b>

TOTAL FACTORED SUBSTRUCTURE LOAD===== 2600 kips  
 TOTAL LENGTH OF SUBSTRUCTURE (along skew)===== 42.83 ft  
 NUMBER OF ROWS OF PILES PER SUBSTRUCTURE===== 3  
 Approx. Factored Loading Applied per pile at 8 ft. Cts===== 161.88 KIPS  
 Approx. Factored Loading Applied per pile at 3 ft. Cts===== 60.71 KIPS

PILE TYPE AND SIZE===== Steel HP 10 X 42  
 Plugged Pile Perimeter===== 3.300 FT. Unplugged Pile Perimeter===== 4.858 FT.  
 Plugged Pile End Bearing Area===== 0.680 SQFT. Unplugged Pile End Bearing Area===== 0.086 SQFT.

BOT. OF LAYER ELEV. (FT.)	LAYER THICK. (FT.)	UNCONF. COMPR. STRENGTH (TSF.)	S.P.T. N VALUE (BLOWS)	GRANULAR OR ROCK LAYER DESCRIPTION	NOMINAL PLUGGED			NOMINAL UNPLUG'D			NOMINAL REQ'D BEARING (KIPS)	FACTORED GEOTECH. LOSS FROM SCOUR or DD (KIPS)	FACTORED GEOTECH. LOSS LOAD FROM DD (KIPS)	FACTORED RESISTANCE AVAILABLE (KIPS)	ESTIMATED PILE LENGTH (FT.)
					SIDE RESIST. (KIPS)	END BRG. RESIST. (KIPS)	TOTAL RESIST. (KIPS)	SIDE RESIST. (KIPS)	END BRG. RESIST. (KIPS)	TOTAL RESIST. (KIPS)					
330.90	2.60	0.30			2.1		4.9	3.1		3.4	3	1	0	1	5
328.40	2.50	0.30			2.0	2.9	17.4	2.9	0.4	7.7	8	2	0	2	7
323.40	5.00	1.40			15.1	13.3	25.9	22.3	1.7	29.1	26	11	0	4	12
318.40	5.00	0.70			8.7	6.7	59.4	12.8	0.8	45.0	45	11	0	14	17
313.40	5.00	3.30	17		27.1	31.5	84.5	39.8	4.0	84.6	85	11	0	36	22
308.40	5.00	3.10	27		25.8	29.6	106.5	38.1	3.7	122.2	107	11	0	48	27
303.40	5.00	2.70	18		23.4	25.7	119.5	34.5	3.3	155.4	119	11	0	55	32
298.40	5.00	1.60			16.6	15.3	133.2	24.4	1.9	179.4	133	11	0	63	37
293.40	5.00	1.30			14.3	12.4	153.3	21.1	1.6	201.3	153	11	0	74	42
288.40	5.00	1.90			18.6	18.1	169.0	27.4	2.3	228.3	169	11	0	82	47
278.40	10.00	1.60			33.2	15.3	188.8	48.8	1.9	275.4	189	11	0	93	57
268.40	10.00	0.20			5.4	1.9	194.3	8.0	0.2	283.4	194	11	0	96	67
265.40	3.00	0.20			1.6	1.9	278.7	2.4	0.2	296.3	279	11	0	143	70
264.40	1.00			Shale	41.1	84.8	319.8	60.5	10.7	356.8	320	11	0	165	71.1
263.40	1.00			Shale	41.1	84.8	360.9	60.5	10.7	417.3	364	11	0	188	72.1
262.40	1.00			Shale	41.1	84.8	402.1	60.5	10.7	477.9	402	11	0	211	73.1
261.40	1.00			Shale	41.1	84.8	443.2	60.5	10.7	538.4	443	11	0	233	74.1
260.40	1.00			Shale	41.1	84.8	484.3	60.5	10.7	598.9	484	11	0	256	75.1
259.40	1.00			Shale	41.1	84.8	525.4	60.5	10.7	659.4	525	11	0	278	76.1
258.40	1.00			Shale	41.1	84.8	566.5	60.5	10.7	719.9	566	11	0	301	77.1
257.40	1.00			Shale	41.1	84.8	607.6	60.5	10.7	780.5	608	11	0	324	78.1
256.40	1.00			Shale	41.1	84.8	648.7	60.5	10.7	841.0	649	11	0	346	79.1
255.40	1.00			Shale	41.1	84.8	689.8	60.5	10.7	901.5	690	11	0	369	80.1
254.40	1.00			Shale	41.1	84.8	730.9	60.5	10.7	962.0	731	11	0	391	81.1
253.40	1.00			Shale	41.1	84.8	772.0	60.5	10.7	1022.6	772	11	0	414	82.1
252.40	1.00			Shale	41.1	84.8	813.1	60.5	10.7	1083.1	813	11	0	437	83.1
251.40	1.00			Shale	41.1	84.8	854.2	60.5	10.7	1143.6	854	11	0	459	84.1
250.40	1.00			Shale	41.1	84.8	895.4	60.5	10.7	1204.1	895	11	0	482	85.1
249.40	1.00			Shale	41.1	84.8	936.5	60.5	10.7	1264.6	936	11	0	504	86.1
248.40	1.00			Shale	41.1	84.8	977.6	60.5	10.7	1325.2	978	11	0	527	87.1
247.40	1.00			Shale	41.1	84.8	1018.7	60.5	10.7	1385.7	1019	11	0	550	88.1
246.40	1.00			Shale	41.1	84.8	1059.8	60.5	10.7	1446.2	1060	11	0	572	89.1
245.40	1.00			Shale	41.1	84.8	1100.9	60.5	10.7	1506.7	1101	11	0	595	90.1
244.40	1.00			Shale	41.1	84.8	1142.0	60.5	10.7	1567.2	1142	11	0	618	91.1
243.40	1.00			Shale	41.1	84.8	1183.1	60.5	10.7	1627.8	1183	11	0	640	92.1
242.40	1.00			Shale	41.1	84.8	1224.2	60.5	10.7	1688.3	1224	11	0	663	93.1
241.40	1.00			Shale	41.1	84.8	1265.3	60.5	10.7	1748.8	1265	11	0	685	94.1
240.40	1.00			Shale		84.8			10.7						



SUBSTRUCTURE===== Pier 2  
 REFERENCE BORING===== 1-S  
 LRFD or ASD or SEISMIC===== LRFD  
 PILE CUTOFF ELEV.===== 335.50 ft  
 GROUND SURFACE ELEV. AGAINST PILE DURING DRIVING = 333.50 ft  
 GEOTECHNICAL LOSS TYPE (None, Scour, Liquef., DD)===== Scour  
 BOTTOM ELEV. OF SCOUR, LIQUEF., or DD===== 317.12 ft  
 TOP ELEV. OF LIQUEF. (so layers above apply DD)===== ft

**MAX. REQUIRED BEARING & RESISTANCE for Selected Pile, Soil Profile, & Losses**

Maximum Nominal Req'd Bearing of Pile	Maximum Nominal Req'd Bearing of Boring	Maximum Factored Resistance Available in Boring	Maximum Pile Driveable Length in Boring
<b>335 KIPS</b>	<b>335 KIPS</b>	<b>178 KIPS</b>	<b>80 FT.</b>

TOTAL FACTORED SUBSTRUCTURE LOAD===== 2600 kips  
 TOTAL LENGTH OF SUBSTRUCTURE (along skew)===== 42.83 ft  
 NUMBER OF ROWS OF PILES PER SUBSTRUCTURE===== 3  
 Approx. Factored Loading Applied per pile at 8 ft. Cts===== 161.88 KIPS  
 Approx. Factored Loading Applied per pile at 3 ft. Cts===== 60.71 KIPS

PILE TYPE AND SIZE===== Steel HP 10 X 42  
 Plugged Pile Perimeter===== 3.300 FT. Unplugged Pile Perimeter===== 4.858 FT.  
 Plugged Pile End Bearing Area===== 0.680 SQFT. Unplugged Pile End Bearing Area===== 0.086 SQFT.

BOT. OF LAYER ELEV. (FT.)	LAYER THICK. (FT.)	UNCONF. COMPR. STRENGTH (TSF.)	S.P.T. N VALUE (BLOWS)	GRANULAR OR ROCK LAYER DESCRIPTION	NOMINAL PLUGGED			NOMINAL UNPLUG'D			NOMINAL REQ'D BEARING (KIPS)	FACTORED GEOTECH. LOSS FROM SCOUR or DD (KIPS)	FACTORED GEOTECH. LOSS LOAD FROM DD (KIPS)	FACTORED RESISTANCE AVAILABLE (KIPS)	ESTIMATED PILE LENGTH (FT.)
					SIDE RESIST. (KIPS)	END BRG. RESIST. (KIPS)	TOTAL RESIST. (KIPS)	SIDE RESIST. (KIPS)	END BRG. RESIST. (KIPS)	TOTAL RESIST. (KIPS)					
332.10	1.40	1.20			3.8		5.7	5.6		5.8	6	2	0	1	3
329.60	2.50	0.20			1.4	1.9	7.0	2.0	0.2	7.8	7	3	0	1	6
324.60	5.00	0.20			2.7	1.9	9.8	4.0	0.2	11.8	10	4	0	1	11
319.60	5.00	0.20			2.7	1.9	18.2	4.0	0.2	16.5	17	6	0	3	16
314.60	5.00	0.80			9.7	7.6	34.6	14.3	1.0	31.7	32	6	0	12	21
309.60	5.00	1.50			15.9	14.3	69.5	23.4	1.8	57.5	57	6	0	26	26
304.60	5.00	3.50	24		28.3	33.4	79.7	41.6	4.2	96.8	80	6	0	38	31
299.60	5.00	1.60			16.6	15.3	99.1	24.4	1.9	121.6	99	6	0	49	36
294.60	5.00	1.90			18.6	18.1	133.0	27.4	2.3	150.9	133	6	0	67	41
289.60	5.00	3.50	24		28.3	33.4	149.8	41.6	4.2	191.0	150	6	0	77	46
279.60	10.00	2.30			42.0	21.9	175.6	61.9	2.8	250.9	176	6	0	91	56
269.60	10.00	0.60			15.2	5.7	187.0	22.3	0.7	272.7	187	6	0	97	66
259.60	10.00	0.20			5.4	1.9	214.3	8.0	0.2	283.5	214	6	0	112	76
257.10	2.50	2.50			11.1	23.8	286.4	16.4	3.0	307.5	286	6	0	152	78
256.10	1.00			Shale	41.1	84.8	327.5	60.5	10.7	368.1	327	6	0	174	79.4
255.10	1.00			Shale	41.1	84.8	368.6	60.5	10.7	428.6	369	6	0	197	80.4
254.10	1.00			Shale	41.1	84.8	409.7	60.5	10.7	489.1	410	6	0	220	81.4
253.10	1.00			Shale	41.1	84.8	450.8	60.5	10.7	549.6	451	6	0	242	82.4
252.10	1.00			Shale	41.1	84.8	491.9	60.5	10.7	610.1	492	6	0	265	83.4
251.10	1.00			Shale	41.1	84.8	533.0	60.5	10.7	670.7	533	6	0	287	84.4
250.10	1.00			Shale	41.1	84.8	574.1	60.5	10.7	731.2	574	6	0	310	85.4
249.10	1.00			Shale	41.1	84.8	615.2	60.5	10.7	791.7	615	6	0	333	86.4
248.10	1.00			Shale	41.1	84.8	656.3	60.5	10.7	852.2	656	6	0	355	87.4
247.10	1.00			Shale	41.1	84.8	697.4	60.5	10.7	912.7	697	6	0	378	88.4
246.10	1.00			Shale	41.1	84.8	738.6	60.5	10.7	973.3	739	6	0	400	89.4
245.10	1.00			Shale	41.1	84.8	779.7	60.5	10.7	1033.8	780	6	0	423	90.4
244.10	1.00			Shale	41.1	84.8	820.8	60.5	10.7	1094.3	821	6	0	446	91.4
243.10	1.00			Shale	41.1	84.8	861.9	60.5	10.7	1154.8	862	6	0	468	92.4
242.10	1.00			Shale	41.1	84.8	903.0	60.5	10.7	1215.3	903	6	0	491	93.4
241.10	1.00			Shale	41.1	84.8	944.1	60.5	10.7	1275.9	944	6	0	513	94.4
240.10	1.00			Shale	41.1	84.8	985.2	60.5	10.7	1336.4	985	6	0	536	95.4
239.10	1.00			Shale	41.1	84.8	1026.3	60.5	10.7	1396.9	1026	6	0	559	96.4
238.10	1.00			Shale	41.1	84.8	1067.4	60.5	10.7	1457.4	1067	6	0	581	97.4
237.10	1.00			Shale	41.1	84.8	1108.5	60.5	10.7	1518.0	1109	6	0	604	98.4
236.10	1.00			Shale	41.1	84.8	1149.6	60.5	10.7	1578.5	1150	6	0	626	99.4
235.10	1.00			Shale	41.1	84.8	1190.7	60.5	10.7	1639.0	1191	6	0	649	100.4
234.10	1.00			Shale	41.1	84.8	1231.9	60.5	10.7	1699.5	1232	6	0	672	101.4
233.10	1.00			Shale		84.8			10.7						

SUBSTRUCTURE===== **South Abut.**  
 REFERENCE BORING ===== **2-S**  
 LRFD or ASD or SEISMIC ===== **LRFD**  
 PILE CUTOFF ELEV. ===== **365.33** ft  
 GROUND SURFACE ELEV. AGAINST PILE DURING DRIVING = **363.33** ft  
 GEOTECHNICAL LOSS TYPE (None, Scour, Liquef., DD) ===== **Scour**  
 BOTTOM ELEV. OF SCOUR, LIQUEF., or DD ===== **363.33** ft  
 TOP ELEV. OF LIQUEF. (so layers above apply DD) ===== ft

**MAX. REQUIRED BEARING & RESISTANCE for Selected Pile, Soil Profile, & Losses**

Maximum Nominal Req'd Bearing of Pile	Maximum Nominal Req'd Bearing of Boring	Maximum Factored Resistance Available in Boring	Maximum Pile Driveable Length in Boring
<b>335</b> KIPS	<b>325</b> KIPS	<b>179</b> KIPS	<b>77</b> FT.

TOTAL FACTORED SUBSTRUCTURE LOAD ===== **1100** kips  
 TOTAL LENGTH OF SUBSTRUCTURE (along skew)===== **42.83** ft  
 NUMBER OF ROWS OF PILES PER SUBSTRUCTURE ===== **1**  
 Approx. Factored Loading Applied per pile at 8 ft. Cts ===== 205.46 KIPS  
 Approx. Factored Loading Applied per pile at 3 ft. Cts ===== 77.05 KIPS

PILE TYPE AND SIZE ===== **Steel HP 10 X 42**  
 Plugged Pile Perimeter===== 3.300 FT. Unplugged Pile Perimeter===== 4.858 FT.  
 Plugged Pile End Bearing Area===== 0.680 SQFT. Unplugged Pile End Bearing Area===== 0.086 SQFT.

BOT. OF LAYER ELEV. (FT.)	LAYER THICK. (FT.)	UNCONF. COMPR. STRENGTH (TSF.)	S.P.T. N VALUE (BLOWS)	GRANULAR OR ROCK LAYER DESCRIPTION	NOMINAL PLUGGED			NOMINAL UNPLUG'D			NOMINAL REQ'D BEARING (KIPS)	FACTORED GEOTECH. LOSS FROM SCOUR or DD (KIPS)	FACTORED GEOTECH. LOSS LOAD FROM DD (KIPS)	FACTORED RESISTANCE AVAILABLE (KIPS)	ESTIMATED PILE LENGTH (FT.)
					SIDE RESIST. (KIPS)	END BRG. RESIST. (KIPS)	TOTAL RESIST. (KIPS)	SIDE RESIST. (KIPS)	END BRG. RESIST. (KIPS)	TOTAL RESIST. (KIPS)					
360.90	2.43	1.10			6.1		16.6	9.0		10.4	10	0	0	6	4
358.40	2.50	1.10			6.3	10.5	23.0	9.3	1.3	19.7	20	0	0	11	7
355.90	2.50	1.10			6.3	10.5	36.0	9.3	1.3	29.8	30	0	0	16	9
353.40	2.50	1.80			9.0	17.2	54.5	13.2	2.2	44.3	44	0	0	24	12
350.90	2.50	2.80			12.0	26.7	95.1	17.7	3.4	65.6	66	0	0	36	14
348.40	2.50	5.80	16		17.1	55.3	96.0	25.2	7.0	88.8	89	0	0	49	17
345.90	2.50	4.10	16		15.9	39.1	111.0	23.5	4.9	112.1	111	0	0	61	19
343.40	2.50	4.00	18		15.6	38.1	136.2	23.0	4.8	136.3	136	0	0	75	22
340.90	2.50	5.00	20		17.1	47.7	146.7	25.2	6.0	160.7	147	0	0	81	24
338.40	2.50	4.30	19		16.5	41.0	169.9	24.4	5.2	186.0	170	0	0	93	27
335.90	2.50	5.00	14		17.1	47.7	182.3	25.2	6.0	210.6	182	0	0	100	29
333.40	2.50	4.50	18		17.1	42.9	159.4	25.2	5.4	230.8	159	0	0	88	32
330.90	2.50	0.30			2.0	2.9	161.4	2.9	0.4	233.7	161	0	0	89	34
328.40	2.50	0.30			2.0	2.9	173.9	2.9	0.4	238.0	174	0	0	96	37
323.40	5.00	1.40			15.1	13.3	182.3	22.3	1.7	259.4	182	0	0	100	42
318.40	5.00	0.70			8.7	6.7	215.8	12.8	0.8	275.3	216	0	0	119	47
313.40	5.00	3.30	17		27.1	31.5	240.9	39.8	4.0	314.9	241	0	0	133	52
308.40	5.00	3.10	27		25.8	29.6	263.0	38.1	3.7	352.5	263	0	0	145	57
303.40	5.00	2.70	18		23.4	25.7	275.9	34.5	3.3	385.7	276	0	0	152	62
298.40	5.00	1.60			16.6	15.3	289.6	24.4	1.9	409.7	290	0	0	159	67
293.40	5.00	1.30			14.3	12.4	309.7	21.1	1.6	431.6	310	0	0	170	72
288.40	5.00	1.90			18.6	18.1	325.4	27.4	2.3	458.6	325	0	0	179	77
278.40	10.00	1.60			33.2	15.3	345.3	48.8	1.9	505.7	345	0	0	190	87
268.40	10.00	0.20			5.4	1.9	350.7	8.0	0.2	513.7	354	0	0	193	97
265.40	3.00	0.20			1.6	1.9	350.4	2.4	0.2	515.9	350	0	0	193	100
264.40	1.00				0.0	0.0	435.2	0.0	0.0	526.6	435	0	0	239	104
263.40	1.00			Shale	41.1	84.8	476.3	60.5	10.7	587.1	476	0	0	262	104.9
262.40	1.00			Shale	41.1	84.8	517.4	60.5	10.7	647.6	517	0	0	285	102.9
261.40	1.00			Shale	41.1	84.8	558.5	60.5	10.7	708.2	558	0	0	307	103.9
260.40	1.00			Shale	41.1	84.8	599.6	60.5	10.7	768.7	600	0	0	330	104.9
259.40	1.00			Shale	41.1	84.8	640.7	60.5	10.7	829.2	641	0	0	352	105.9
258.40	1.00			Shale	41.1	84.8	681.8	60.5	10.7	889.7	682	0	0	375	106.9
257.40	1.00			Shale	41.1	84.8	722.9	60.5	10.7	950.2	723	0	0	398	107.9
256.40	1.00			Shale	41.1	84.8	764.0	60.5	10.7	1010.8	764	0	0	420	108.9
255.40	1.00			Shale	41.1	84.8	805.1	60.5	10.7	1071.3	805	0	0	443	109.9
254.40	1.00			Shale	41.1	84.8	846.2	60.5	10.7	1131.8	846	0	0	465	110.9
253.40	1.00			Shale	41.1	84.8	887.3	60.5	10.7	1192.3	887	0	0	488	111.9
252.40	1.00			Shale		84.8			10.7						