

F.A.I. RTE. NO.	SECTION	COUNTY	TOTAL SHEETS	SHEET NO.
90/94	2003-0311	COOK	976	128
STA. 2011+00		TO STA. 2000+00		
FED. ROAD DIST. NO.	ILLINOIS FED. AID PROJECT			

62583



NOTES:

- SEE DRAWINGS ME-01 AND ME-02 FOR ELECTRICAL SYMBOLS AND ABBREVIATIONS.
- UNLESS NOTED OTHERWISE, ALL ITEMS AND WORK SHOWN IN HEAVY LINE WEIGHT ON THIS DRAWING ARE PROPOSED NEW ITEMS AND WORK.
- SEE DRAWING ES-01 FOR HIGH MAST LIGHT TOWER SCHEDULE.
- THE EXISTING ROADWAY LIGHTING SYSTEM SHALL REMAIN IN OPERATION UNTIL THE PROPOSED ROADWAY LIGHTING SYSTEM HAS BEEN INSTALLED, ENERGIZED, TESTED, AND ACCEPTED BY THE ENGINEER, UNLESS OTHERWISE DIRECTED BY THE ENGINEER.
- ALL JUNCTION BOXES MOUNTED ON OVERPASS STRUCTURES SHALL BE INSTALLED AS SHOWN ON DRAWING ME-06, UNLESS OTHERWISE NOTED.
- REPLACE EXISTING JUNCTION BOX WITH PROPOSED AS INDICATED. ROUTE EXISTING AND PROPOSED RIGID CONDUITS TO JUNCTION BOX. CONNECT PROPOSED CIRCUITS TO EXISTING CIRCUITS. REFER SINGLE LINE DIAGRAM SLO5-02. THIS WORK SHALL BE PAID FOR UNDER "JUNCTION BOX, STAINLESS STEEL, ATTACHED TO STRUCTURE, 12"x10"x6"".
- UNDERPASS LIGHTING AT DR. M.L. KING JR. DRIVE IS NOT PART OF THIS CONTRACT.
- UNIT DUCT TRENCH DEPTH SHALL BE ADJUSTED TO PERMIT FINAL GRADING WITHOUT DAMAGE TO UNIT DUCT.

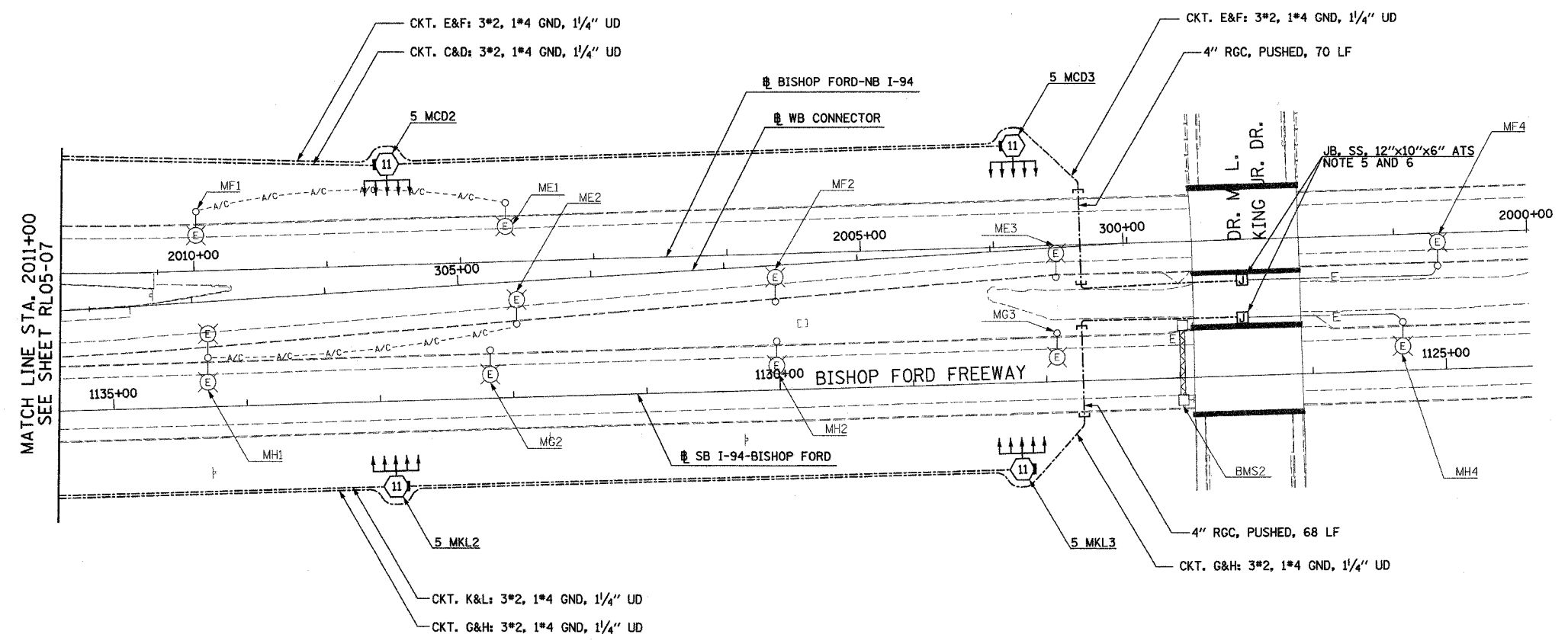

MATCH LINE STA. 2011+00
SEE SHEET RL05-07

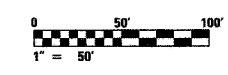

RL05-08

SINGH 300 W. ADAMS ST.
CHICAGO, IL 60606
SINGH & ASSOCIATES, INC. TEL: (312) 629-0240
CONSULTING ENGINEERS FAX: (312) 629-8449

REVISIONS	
NAME	DATE

ILLINOIS DEPARTMENT OF TRANSPORTATION
F.A.I. 90/94 (DAN RYAN EXPRESSWAY)
31st STREET TO I-57

ROADWAY LIGHTING PLANS
PROPOSED IMPROVEMENTS 2005

SCALE: 1"=50'
DATE: OCTOBER 29, 2004
DRAWN BY: VRK
CHECKED BY: TM

10/21/2004 4:05:47 PM