

62680

F.A. RTE.	SECTION	COUNTY	TOTAL SHEET NO.
2714	2003-095 RS	COOK	23
STA.	TO STA.		11
FED. ROAD DIST. NO.	ILLINOIS	FED. AID PROJECT	

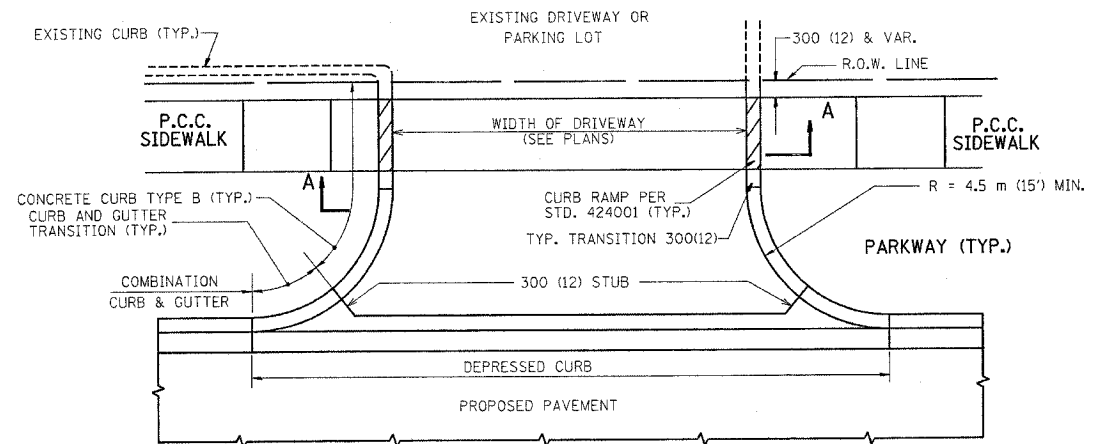

WITH CONCRETE CURB, TYPE B

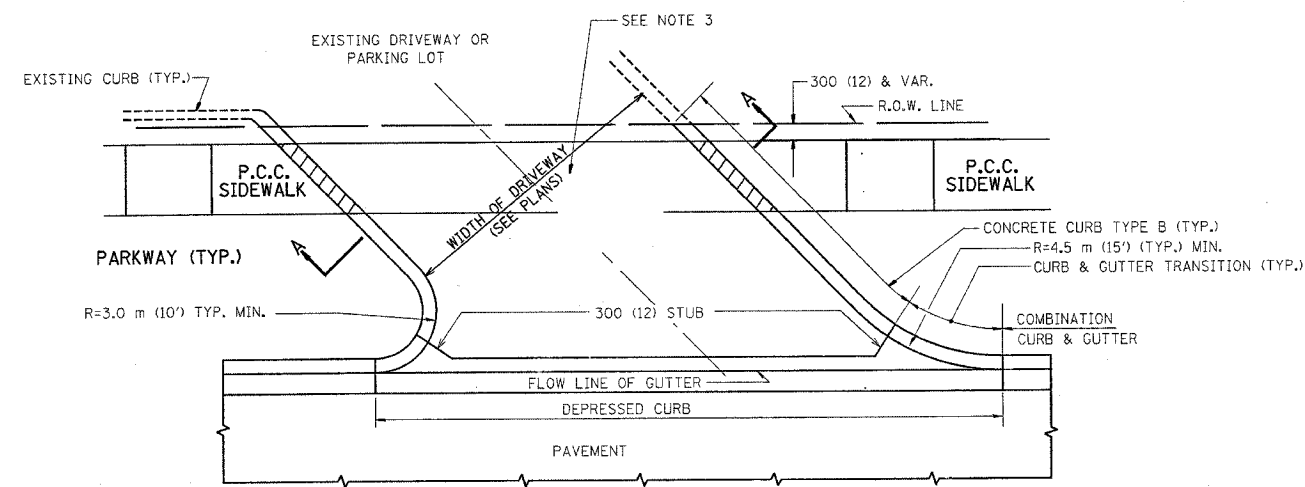

WITH CONCRETE CURB, TYPE B

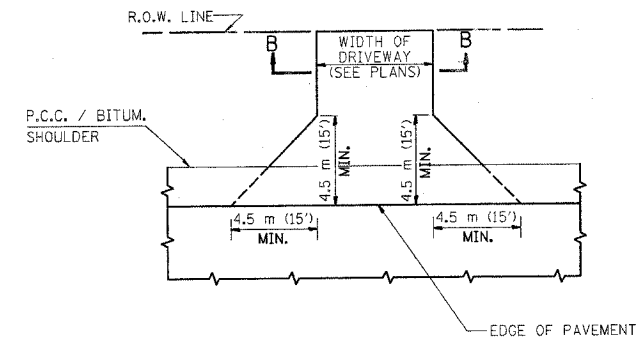

ADJACENT TO P.C.C. / BITUMINOUS SHOULDER

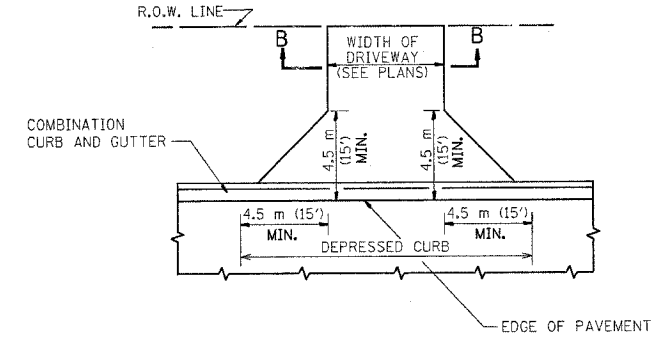

ADJACENT TO CURB AND GUTTER

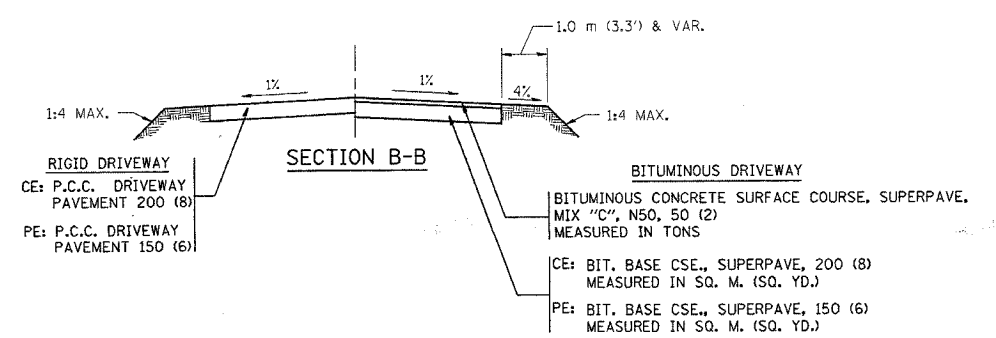

RURAL FIELD ENTRANCE (FE)
 BITUMINOUS CONCRETE SURFACE COURSE, SUPERPAVE MIX "C", N50, 50 (2) MEASURED IN TONS
 CE: BIT. BASE CSE., SUPERPAVE, 200 (8) MEASURED IN SQ. M. (SQ. YD.)
 PE: BIT. BASE CSE., SUPERPAVE, 150 (6) MEASURED IN SQ. M. (SQ. YD.)

GENERAL NOTES:

DRIVEWAY SLOPES, LOCATIONS, & GEOMETRIC LAYOUT SHALL BE IN ACCORDANCE WITH THE LATEST EDITION OF THE "HANDBOOK FOR POLICY ON PERMITS FOR ACCESS DRIVEWAYS TO STATE HIGHWAYS". FOR FURTHER LAYOUT REQUIREMENTS, REFER TO ILLUSTRATIONS IN THE PERMIT HANDBOOK. DRIVEWAYS SHALL BE REPLACED IN KIND, UNLESS OTHERWISE NOTED ON THE PLANS.

COMMERCIAL DRIVEWAYS SHALL BE CONSTRUCTED WITH CONCRETE CURB, TYPE B RETURNS EXCEPT WHEN THE SIDEWALK EDGE IS 1.2 METERS (4 FEET) OR LESS FROM THE BACK OF CURB, CONSTRUCT A FLARE DRIVEWAY WITHOUT CURB.

THE RESIDENT ENGINEER SHALL CONTACT THE TRAFFIC PERMIT OFFICE AT 847/ 705-4131 FOR ANY QUESTIONS ON DRIVEWAYS SHOWN IN THE PLANS; SPECIFICALLY IN REFERENCE TO ADDITIONAL AND/OR RELOCATION/REMOVAL OF A DRIVEWAY.

COMBINATION CONCRETE CURB & GUTTER SHALL BE MEASURED STRAIGHT ACROSS THE DRIVEWAY. NO ADDITIONAL COMPENSATION WILL BE ALLOWED FOR THE CURB & GUTTER TRANSITION.

25 (1) PREFORMED EXPANSION JOINT FILLER WILL NOT BE PAID SEPARATELY, BUT SHALL BE CONSIDERED INCLUDED IN THE COST OF THE P.C.C. DRIVEWAY PAVEMENT OR P.C.C. SIDEWALK.

WHEN THE P.C.C. SIDEWALK EXTENDS THROUGH THE DRIVEWAY, THE THICKNESS OF THE SIDEWALK IN THE DRIVEWAY AREA SHALL BE THE SAME AS THE DRIVEWAY THICKNESS. SIDEWALK WILL BE PAID FOR AS P.C.C. SIDEWALK OF THE THICKNESS SPECIFIED. SIDEWALK CROSS SLOPE THRU DRIVEWAY AREA TO BE A MAXIMUM OF 1:50.

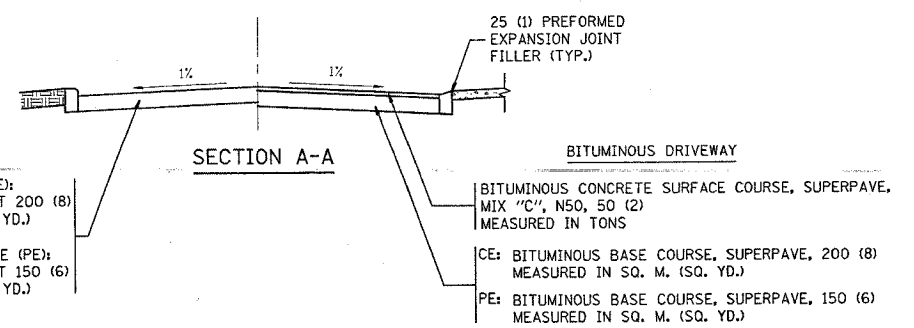

RIGID DRIVEWAY
 COMMERCIAL ENTRANCE (CE):
 P.C.C. DRIVEWAY PAVEMENT 200 (8) MEASURED IN SQ. M. (SQ. YD.)
 NON-COMMERCIAL ENTRANCE (PE):
 P.C.C. DRIVEWAY PAVEMENT 150 (6) MEASURED IN SQ. M. (SQ. YD.)

BITUMINOUS DRIVEWAY
 BITUMINOUS CONCRETE SURFACE COURSE, SUPERPAVE, MIX "C", N50, 50 (2) MEASURED IN TONS
 CE: BITUMINOUS BASE COURSE, SUPERPAVE, 200 (8) MEASURED IN SQ. M. (SQ. YD.)
 PE: BITUMINOUS BASE COURSE, SUPERPAVE, 150 (6) MEASURED IN SQ. M. (SQ. YD.)

ALL DIMENSIONS ARE IN MILLIMETERS (INCHES) UNLESS OTHERWISE NOTED

REVISIONS	
NAME	DATE
P. LAFLEUR	04-15-03
R. SHAH	11-04-95
J. POLLASTRINI	08-12-96
J. POLLASTRINI	12-14-96
A. ABBAS	03-21-97
T. HOLTZ	04-08-97
M. GOMEZ	04-06-01

ILLINOIS DEPARTMENT OF TRANSPORTATION
DRIVEWAY DETAILS
 DISTANCE BETWEEN R.O.W. AND FACE OF CURB / EDGE OF SHOULDER >= 4.5 m (15')

SCALE: VERT. HORIZ. DATE: 9/27/2004 DRAWN BY CHECKED BY