

| F.A. DIST. | SECTION | COUNTY | TOTAL SHEETS | SHEET NO. |
|---------------------|-------------|------------------|--------------|-----------|
| 2714 | 2003-095 RS | COOK | 23 | 15 |
| STA. | | TO STA. | | |
| FED. ROAD DIST. NO. | ALIGN. | FED. AID PROJECT | | |

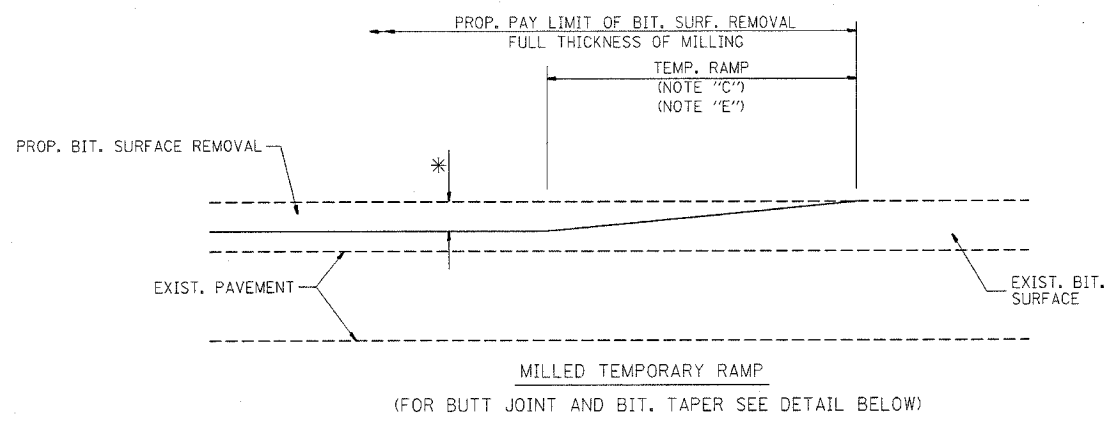

OPTION 1

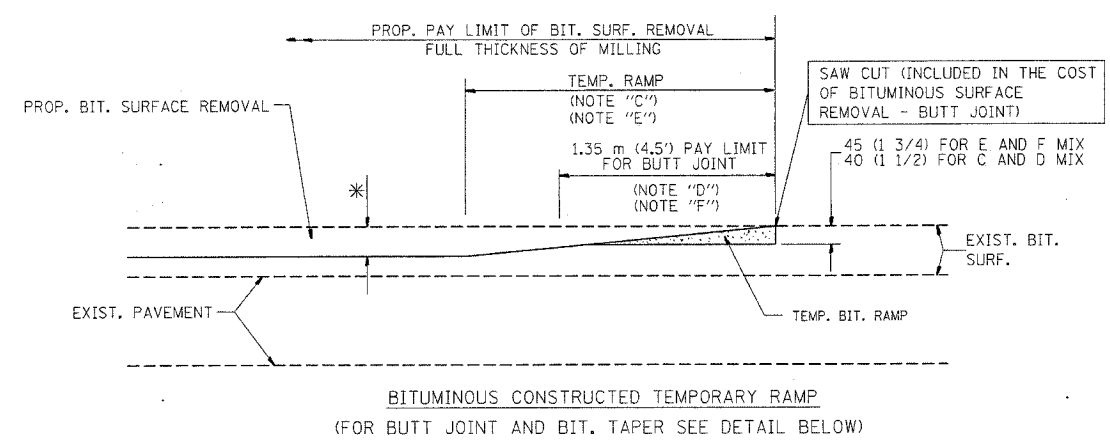

OPTION 2
TYPICAL TEMPORARY RAMP

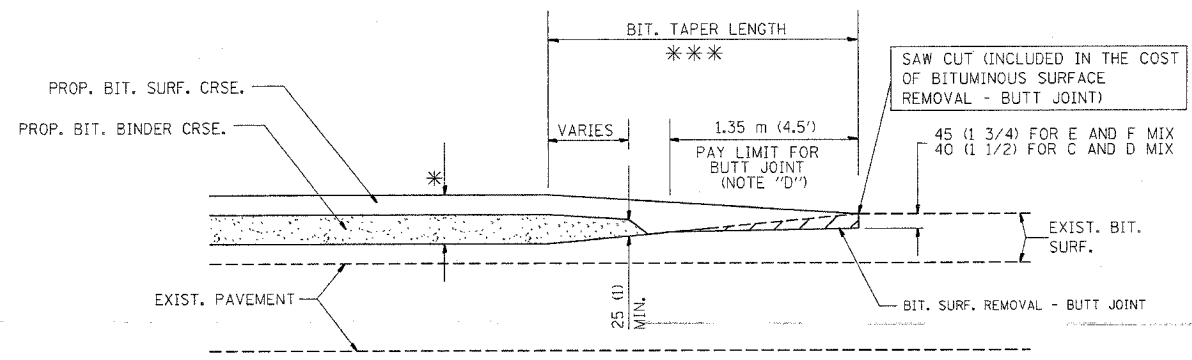

TYPICAL BUTT JOINT AND BITUMINOUS TAPER FOR MILLING AND RESURFACING

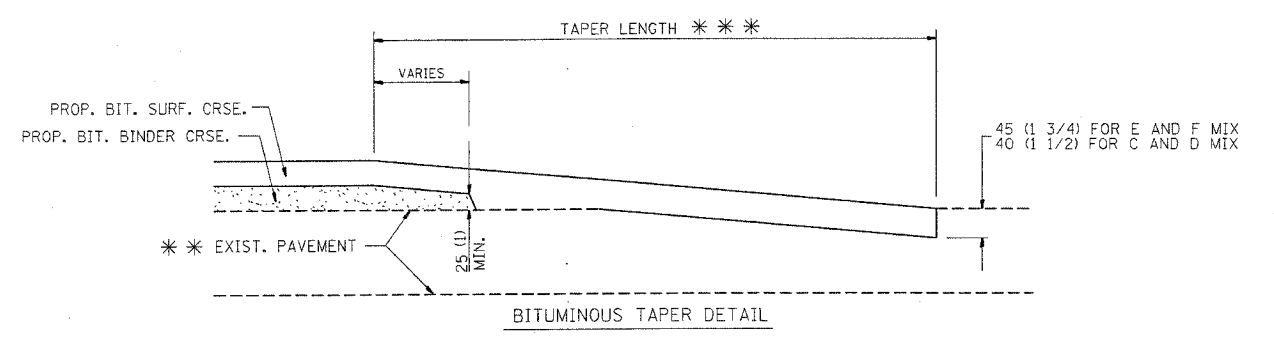
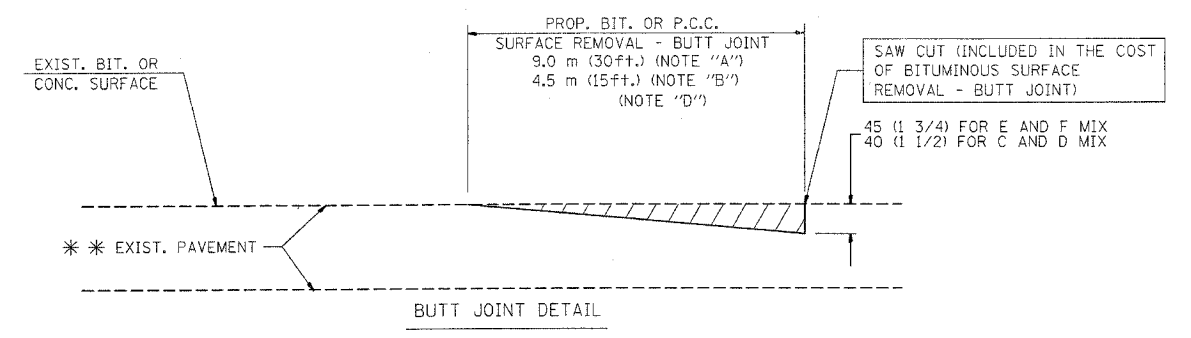

TYPICAL BUTT JOINT AND BITUMINOUS TAPER FOR RESURFACING ONLY

*** PC CONCRETE, BITUMINOUS OR BITUMINOUS RESURFACED PAVEMENT.

NOTES

- A: MAINLINE ROADWAYS AND MAJOR SIDE ROADS.
 - B: MINOR SIDE ROADS.
 - C: THE TEMP. RAMP SHALL BE CONSTRUCTED IMMEDIATELY UPON REMOVAL OF THE EXISTING BITUMINOUS SURFACE.
 - D: THE BUTT JOINT SHALL BE CONSTRUCTED IMMEDIATELY PRIOR TO PLACING THE PROPOSED BITUMINOUS COURSES.
 - E: TAPER THE TEMP. RAMP AT A RATE OF 900 (3 ft.) PER INCH OF MILLING THICKNESS.
 - F: INSTALLATION AND REMOVAL OF THE 1.35 m (4.5') TEMP. BIT. RAMP WILL BE PAID AS "BITUMINOUS SURFACE REMOVAL - BUTT JOINT".
 - G: SEE ARTICLE 406.18 AND 406.24 OF THE STANDARD SPECIFICATIONS FOR "BITUMINOUS AND PCC SURFACE REMOVAL, BUTT JOINT".
- * SEE TYPICAL SECTIONS FOR MILLING THICKNESS.

*** 6.1 m (20') PER 25 (1) RESURFACING (NOTE "A")
3.0 m (10') PER 25 (1) RESURFACING (NOTE "B")

ALL DIMENSIONS ARE IN MILLIMETERS (INCHES) UNLESS OTHERWISE SHOWN.

BASIS OF PAYMENT:

THE BUTT JOINT WILL BE PAID FOR PER SQUARE METER (SQUARE YARD.) AS "BITUMINOUS SURFACE REMOVAL - BUTT JOINT" OR AS "PORTLAND CEMENT CONCRETE SURFACE REMOVAL - BUTT JOINT".

| REVISIONS | |
|------------|----------|
| NAME | DATE |
| M. DE YONG | 6-13-90 |
| M. DE YONG | 7-3-90 |
| M. DE YONG | 3-27-92 |
| R. SHAH | 09/09/94 |
| R. SHAH | 10/25/94 |
| A. ABBAS | 03/21/97 |
| M. GOMEZ | 04/06/01 |

ILLINOIS DEPARTMENT OF TRANSPORTATION

BUTT JOINT AND BITUMINOUS TAPER DETAILS

SCALE: NONE
DATE PLOTTED: 9/27/2004

DRAWN BY
CHECKED BY
BD400-05 (VI=BD32)