

PLAN

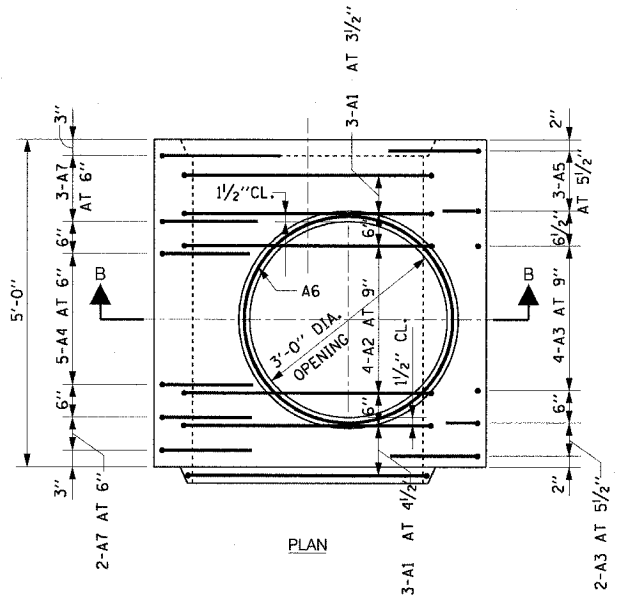

PLAN

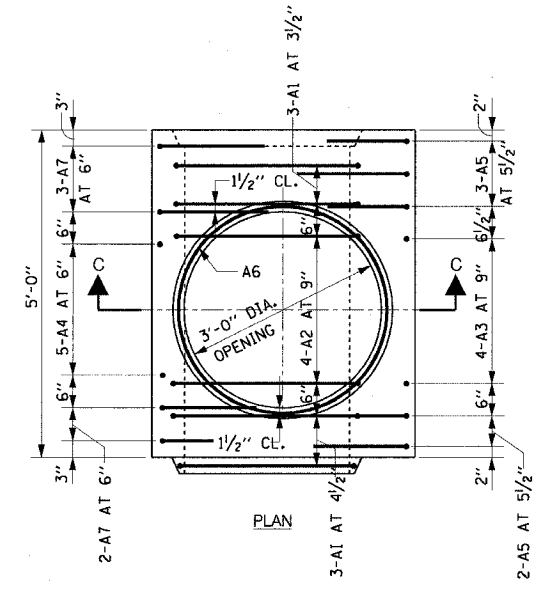

PLAN

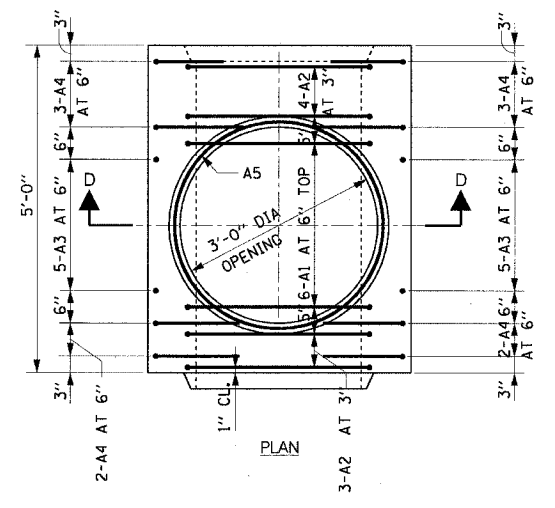

PLAN

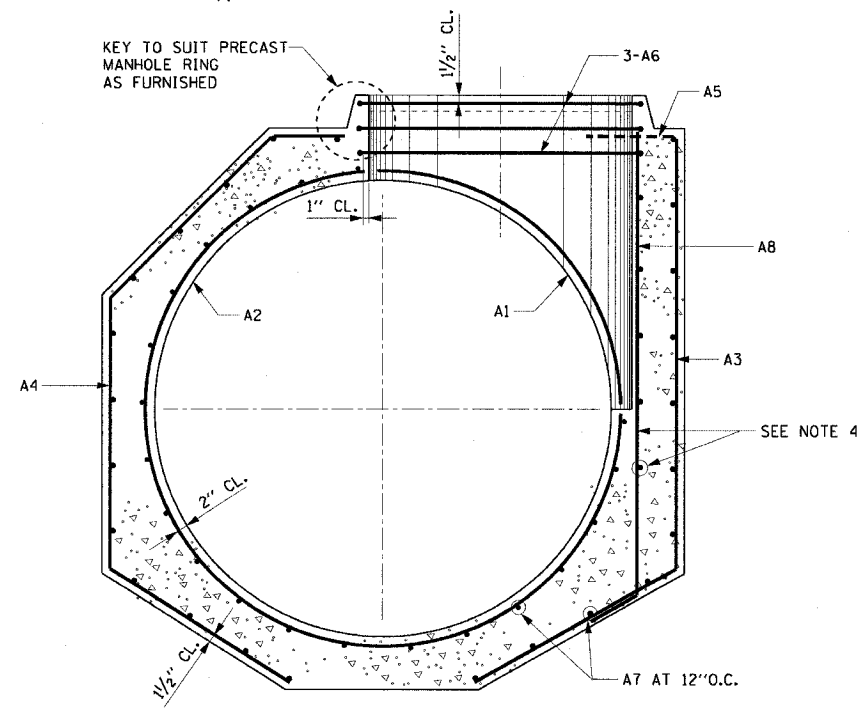

SECTION A-A
MANHOLE BASE FOR SEWER
48" DIA. AND 120" DIA. INCLUSIVE

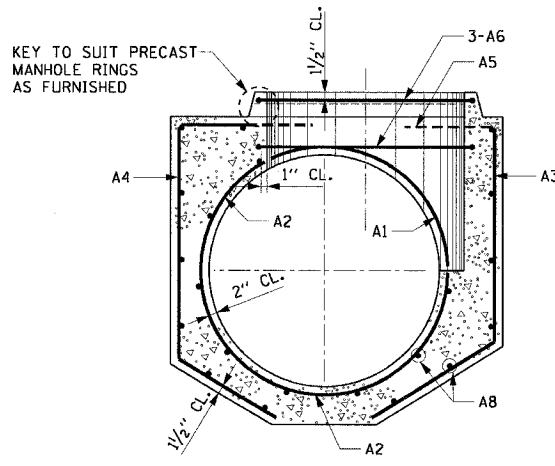

SECTION B-B
MANHOLE BASE FOR SEWERS
36" DIA. AND 42" DIA.

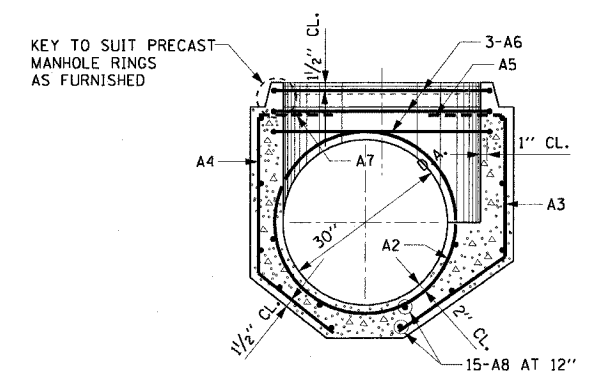

SECTION C-C
MANHOLE BASE
FOR 30" DIA. SEWERS

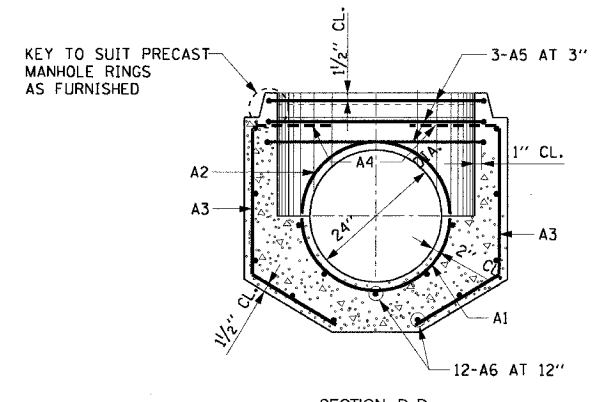

SECTION D-D
MANHOLE BASE
FOR 24" DIA. SEWERS



REVISIONS	
NAME	DATE

ILLINOIS DEPARTMENT OF TRANSPORTATION
F.A.I. 90/94 (DAN RYAN EXPRESSWAY)
63rd ST TO 59th ST (FRONTAGE ROAD & RAMPS)
DRAINAGE DETAILS
REINFORCEMENT FOR TYPE "A"
PRECAST MANHOLE BASES
SCALE: NONE
DATE: October 29, 2004
DRAWN BY: JB
CHECKED BY: EBY

10/29/2004 02:07:37 PM