

PLAN

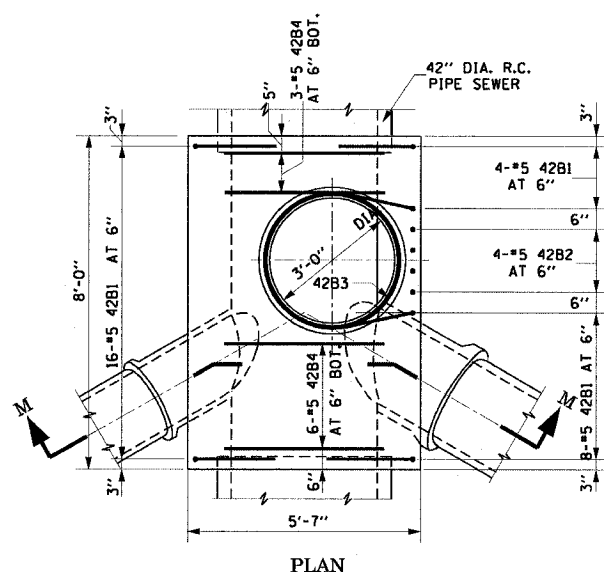

PLAN

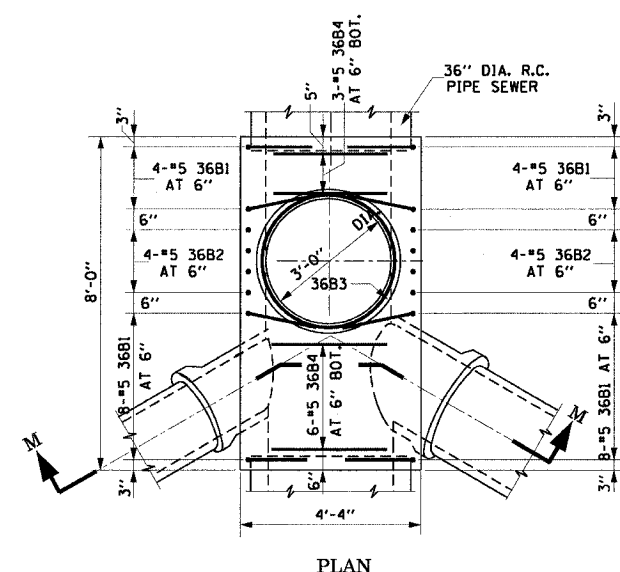

PLAN

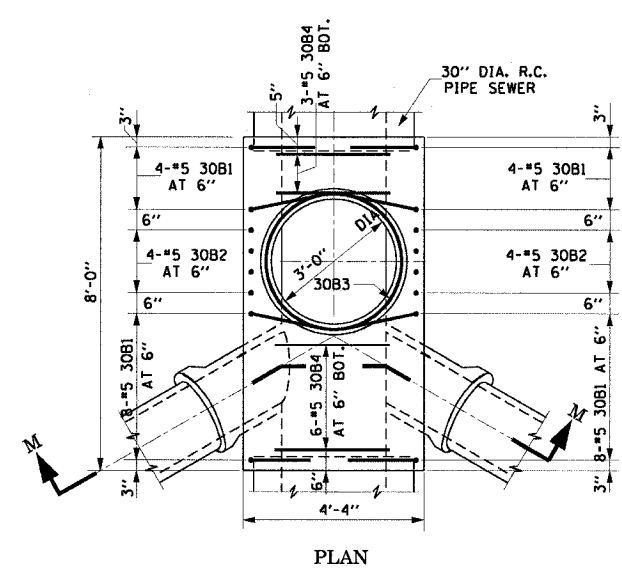

PLAN

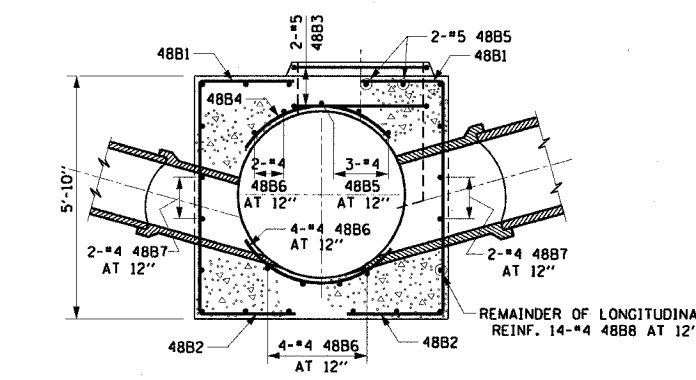

SECTION M-M
48" DIA. SEWER

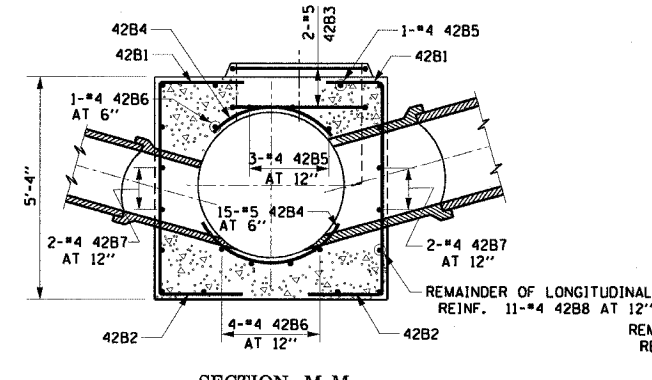

SECTION M-M
42" DIA. SEWER

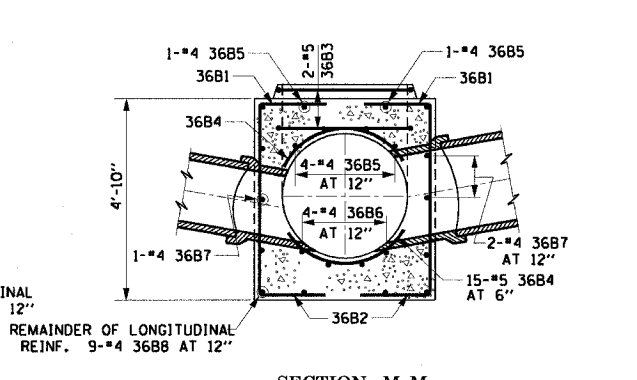

SECTION M-M
36" DIA. SEWER

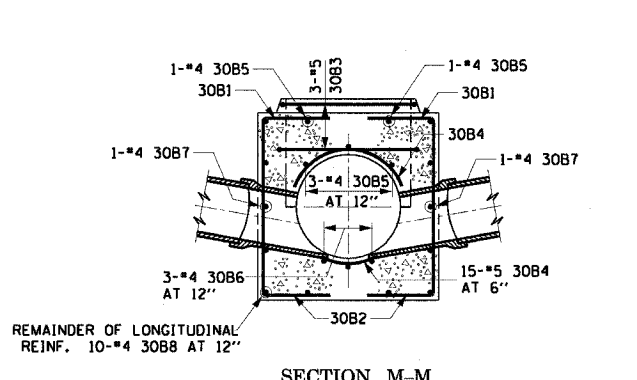

SECTION M-M
30" DIA. SEWER

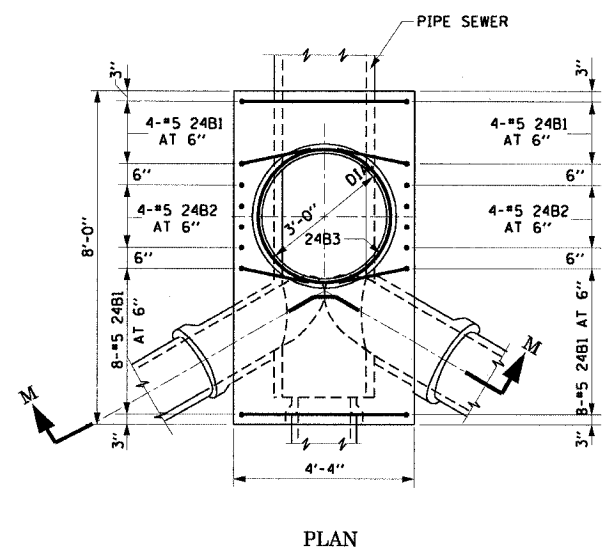

PLAN

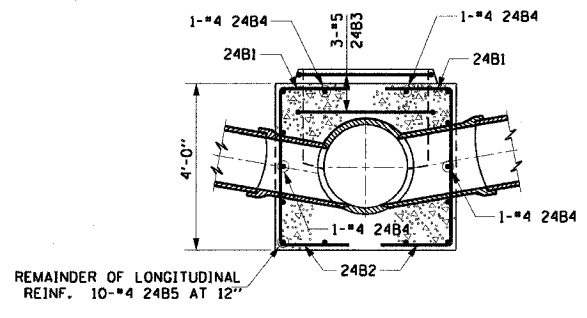

SECTION M-M

24" DIA. SEWERS AND SMALLER

REVISIONS	
NAME	DATE

ILLINOIS DEPARTMENT OF TRANSPORTATION
 F.A.I. 90/94 (DAN RYAN EXPRESSWAY)
 63rd ST TO 59th ST (FRONTAGE ROAD & RAMPS)

**DRAINAGE DETAILS
 REINFORCEMENT FOR TYPE "B"
 PRECAST MANHOLE BASES**

SCALE: NONE
 DATE: October 29, 2004

DRAWN BY: JB
 CHECKED BY: EEE