

STATE OF ILLINOIS
DEPARTMENT OF TRANSPORTATION

BILL OF MATERIAL **

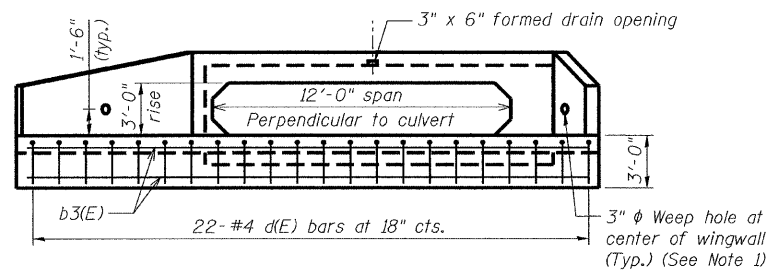

END ELEVATION

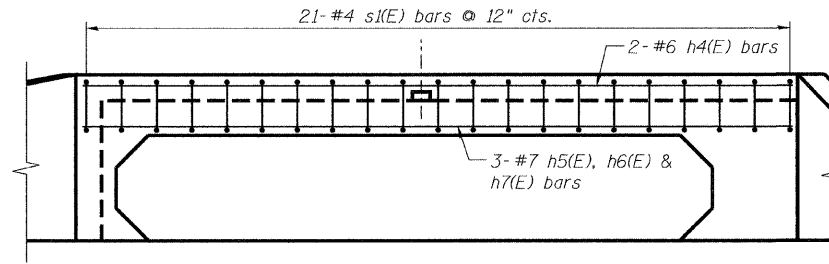

HEADWALL ELEVATION

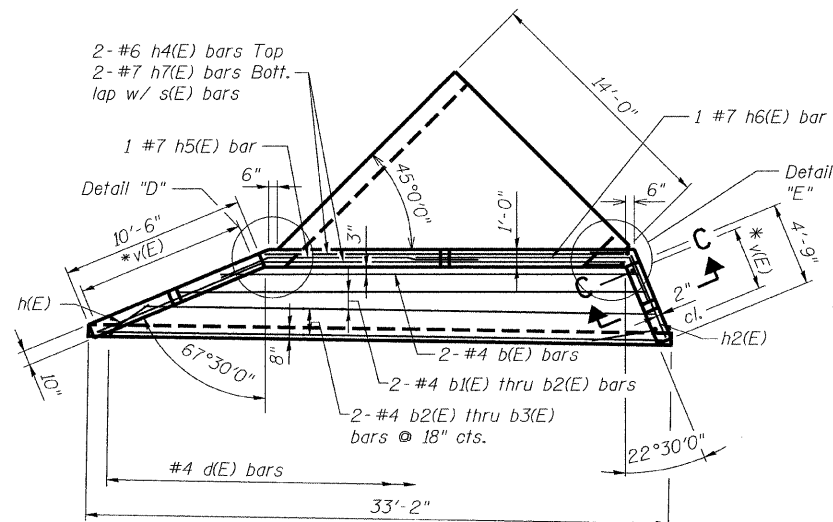

PLAN

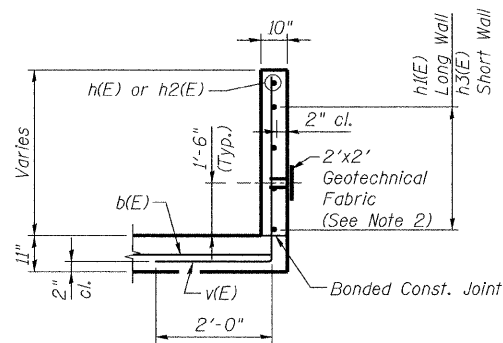

SECTION C-C
(Long Wall Similar)

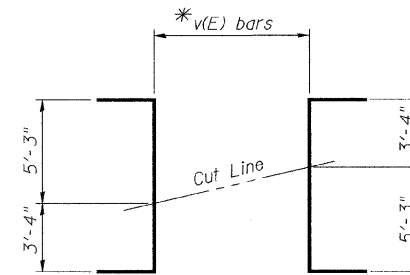

FIELD CUTTING DIAGRAM

* Order v(E) bars full length. Cut to fit as shown and use remainder of bars in other side of apron.

Bar	Size	No.	Length	Shape
b(E)	#4	4	23'-9"	—
b1(E)	#4	2	26'-7"	—
b2(E)	#4	2	29'-2"	—
b3(E)	#4	4	32'-2"	—
d(E)	#4	44	5'-4"	└
h(E)	#5	2	10'-6"	—
h1(E)	#5	8	10'-3"	—
h2(E)	#5	2	4'-9"	—
h3(E)	#5	8	4'-6"	—
h4(E)	#6	4	20'-6"	—
h5(E)	#7	2	15'-6"	—
h6(E)	#7	2	15'-6"	—
h7(E)	#7	4	20'-6"	—
s(E)	#4	8	44'-0"	□
s1(E)	#4	42	5'-3"	□
v(E)	#6	16	12'-7"	└
Item		Unit	Total	
Class SI Concrete		C.Y.	19	
Reinforcement Bars, Epoxy Coated		Lbs.	1,640	

** For two aprons. The quantities shown are for information only.

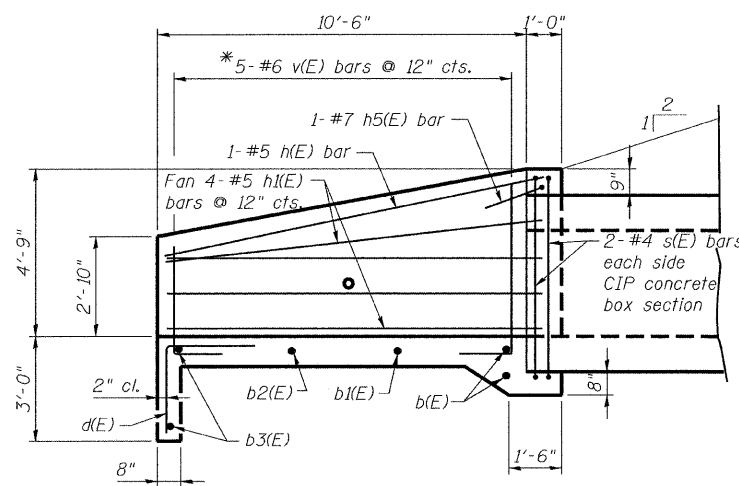

LONG WALL ELEVATION
(NW / SE Corner)

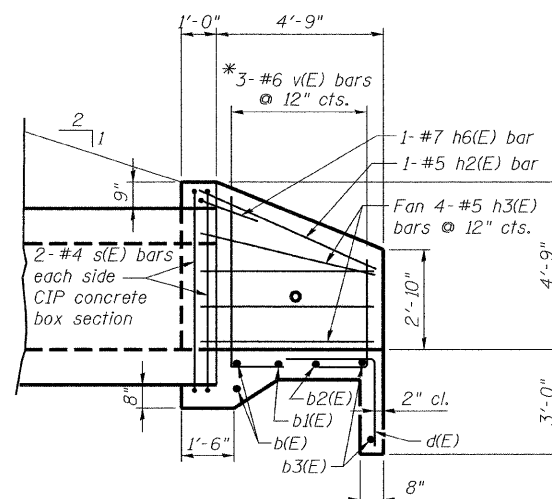

SHORT WALL ELEVATION
(NE / SW Corner)

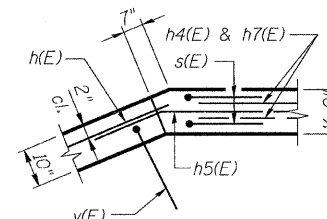

DETAIL "D"

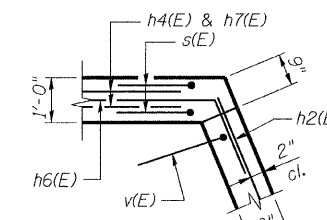

DETAIL "E"

MIN. BAR LAP
#6 - 2'-0"
#7 - 2'-9"

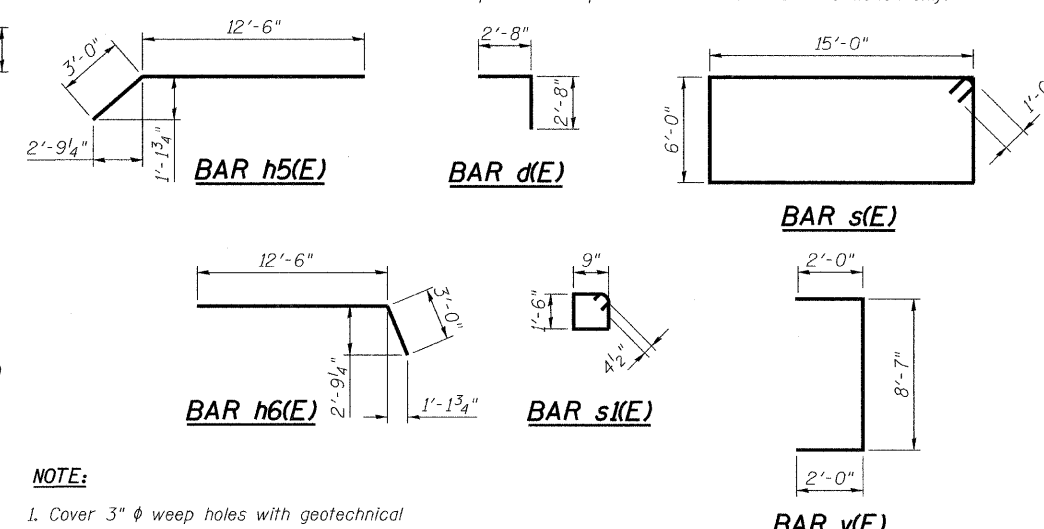

CAST IN PLACE APRON DETAILS
STRUCTURE NO. 027-2551

NOTE:
1. Cover 3" diameter weep holes with geotechnical fabric for box culvert end section and precast box culvert. Cost included with Precast Concrete Box Culvert.

DESIGNED	MFB/JDC
CHECKED	MRB
DRAWN	PT
CHECKED	MFB

benesch

alfred benesch & company
Engineers • Surveyors • Planners
205 North Michigan Avenue, Suite 2400
Chicago, Illinois 60601
312-565-0450
Job # 3938.02

SHEET NO. S4	F.A.P. RTE. 796	SECTION 104 I & 105 BR-1	COUNTY FORD	TOTAL SHEETS 51	SHEET NO. 40
SHEETS S7	CONTRACT NO. 66848		ILLINOIS FED. AID PROJECT		