

STATE OF ILLINOIS  
DEPARTMENT OF TRANSPORTATION

F.A.P. RTE.	SECTION	COUNTY	TOTAL SHEETS	SHEET NO.
315/30	139,138(BC;BC-1)BR, BR-1	FULTON	119	1
	ILLINOIS		CONTRACT NO. 68H20	

**INDEX OF SHEETS**  
SEE SHEET 2 FOR "INDEX OF SHEETS"

**HIGHWAY STANDARDS**  
SEE SHEET 2 FOR "HIGHWAY STANDARDS"

**PROPOSED  
HIGHWAY PLANS**

FAP ROUTE 315 / 30 (US 136 / IL 78 / IL 97)  
SECTION [139,138(BC;BC-1)BR, BR-1]BRR  
PROJECT NHPP-STP-G75Y (951)  
TYPE of IMPROVEMENT : BRIDGE PRESERVATION  
FULTON COUNTY

C-94-059-22



**DESIGN DESIGNATION**

US 136 : AADT 5,600 (1,125) - 2021 OTHER PRINCIPAL ARTERIAL  
IL 78 / 97 : AADT 3,300 (415) - 2021 MINOR ARTERIAL  
POSTED SPEED: 55 / DESIGN SPEED: 55

2351 S. DIRKSEN PKWY  
SPRINGFIELD, ILLINOIS 62703  
217-670-0563 (P)  
www.quiggeengineering.com

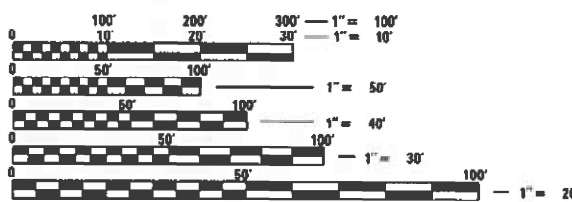

FULL SIZE PLANS HAVE BEEN PREPARED USING STANDARD ENGINEERING SCALES. REDUCED SIZED PLANS WILL NOT CONFORM TO STANDARD SCALES. IN MAKING MEASUREMENTS ON REDUCED PLANS, THE ABOVE SCALES MAY BE USED.

J.U.L.I.E.  
JOINT UTILITY LOCATION INFORMATION FOR EXCAVATION  
1-800-892-0123  
OR 811

PROJECT ENGINEER: KAREN DVORSKY (309)671-3490  
PROJECT MANAGER: ELIAS ELDERZI (309)671-3482  
CATALOG NO. 036336-000  
CONTRACT NO. 68H20

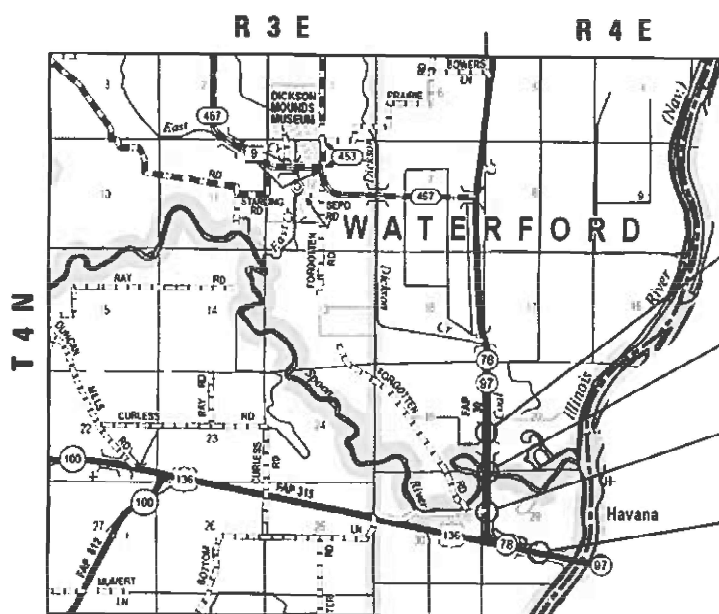

**LOCATION MAP**  
GROSS LENGTH = 3,364.75.00 FT. = 0.637 MILE  
NET LENGTH = 3,364.75 FT. = 0.637 MILE

APPROXIMATE SCALE

TOWNSHIP: WATERFORD  
SECTIONS: 20 & 29

- SN 029-0055 (IL 78 / IL 97)  
OVER SPOON RIVER OVERFLOW  
STA 488+45.00 TO STA 497+50.00
- SN 029-0056 (IL 78 / IL 97)  
OVER SPOON RIVER  
STA 502+60.00 TO STA 513+60.00
- SN 029-0021 (IL 78 / IL 97)  
OVER LACEY DITCH  
STA 532+30.00 TO STA 538+14.75
- SN 029-0012 (US 136)  
OVER LACEY DITCH  
STA 321+30.00 TO STA 328+85.00



*Stephen M. Kehoe*  
STEPHEN M. KEHOE ILLINOIS P.E. 62-048103 DATE 12/14/2023  
EXPIRES 11/30/2025  
SIGNATURE AND SEAL APPLY TO ALL SHEETS EXCEPT AS NOTED BELOW: SHEETS 83 - 119

STATE OF ILLINOIS  
DEPARTMENT OF TRANSPORTATION

SUBMITTED December 15, 2023  
*Rensil J. Barnette, Inc.*  
REGIONAL ENGINEER

February 2, 2024 *Scott A. Etk*  
ENGINEER OF DESIGN AND ENVIRONMENT

February 2, 2024 *Stephen M. Kehoe*  
DIRECTOR OF HIGHWAYS PROJECT IMPLEMENTATION

**PRINTED BY THE AUTHORITY  
OF THE STATE OF ILLINOIS**

## INDEX OF SHEETS

SHEET NO.	DESCRIPTION
1	COVER SHEET
2	GENERAL NOTES, INDEX OF SHEETS AND HIGHWAY STANDARDS
3 - 7	SUMMARY OF QUANTITIES
8 - 10	SCHEDULE OF QUANTITIES
11 - 12	EXISTING TYPICAL SECTIONS
13	PROPOSED TYPICAL SECTIONS
14 - 22	REMOVAL PLANS
23 - 31	ROADWAY PLANS
32 - 36	MAINTENANCE OF TRAFFIC PLANS - US 136 (SN 029-0012)
37 - 41	MAINTENANCE OF TRAFFIC PLANS - IL 78 / 97 (SN 029-0055)
42 - 48	MAINTENANCE OF TRAFFIC PLANS - IL 78 / 97 (SN 029-0056)
49 - 57	MAINTENANCE OF TRAFFIC PLANS - IL 78 / 97 (SN 029-0021)
58	BUTT JOINT DETAILS
59 - 60	RURAL ENTRANCES FOR "3R" PROJECTS
61 - 62	GUARDRAIL EROSION CONTROL TREATMENTS
63 - 76	STRUCTURE PLANS (SN 029-0012)
77 - 91	STRUCTURE PLANS (SN 029-0055)
92 - 106	STRUCTURE PLANS (SN 029-0056)
107 - 119	STRUCTURE PLANS (SN 029-0021)

## TEMPORARY TRAFFIC SIGNAL NOTES

1. TRAFFIC CONTROL SHALL BE IN ACCORDANCE WITH STANDARD 701321 EXCEPT WHEN MODIFIED ON THESE PLAN SHEETS.
2. THREE PHASE SIGNAL OPERATION IS REQUIRED FOR STAGES I AND II. FOR S.N. 029-0021, 029-0056. TWO PHASE SIGNAL OPERATION IS REQUIRED FOR STAGES I AND II. FOR S.N. 029-0012, 029-0055.
3. THE CONTRACTOR SHALL INSTALL EITHER DETECTOR LOOPS OR MICROWAVE DETECTORS FOR USE WITH THE TEMPORARY TRAFFIC SIGNALS IN ACCORDANCE WITH HIGHWAY STANDARD 701321.
4. THE ENGINEER OF TRAFFIC SHALL APPROVE ALL TIMING PARAMETERS.
5. THE CONTRACTOR SHALL CONTACT TONY BRIDSON, DISTRICT 4 TRAFFIC SIGNAL TECHNICIAN, AT (309) 671-4464, FOURTY-EIGHT HOURS PRIOR TO SIGNAL TURN ON.
6. ALL TRAFFIC SIGNAL SECTIONS SHALL HAVE 12" DIAMETER LED LENSES.
7. THE TEMPORARY TRAFFIC SIGNAL HEADS SHALL BE PLACED AT THE LOCATIONS INDICATED ON THE PLAN SHEETS OR DIRECTED BY THE ENGINEER.
8. THE TEMPORAY TRAFFIC SIGNALINSTALLATION SHALL CONFORM TO ALL MUTCD STANDARDS.
9. A MINIMUM OF 2 SIGNAL HEADS ARE REQUIRED PER APPROACH.
10. ALL SIGNAL HEADS SHALL BE EQUIPPED WITH REFLECTORIZED BACKPLATES.
11. ALL LABOR, EQUIPMENT, AND MATERIALS REQUIRED TO COMPLY WITH THESE REQUIREMENTS AND PLAN SHEET DETAILS SHALL BE INCLUDED IN THE CONTRACT BID PRICE FOR THE TEMPORARY BRIDGE SIGNAL INSTALLATION, THERE WILL BE NO ADDITIONAL COMPENSATION.

## JOB SPECIFIC NOTES

1. THE MAINTENANCE OF TRAFFIC CONTROL (MOT) PLANS SHALL SERVE A GUIDE FOR SAFE DIVERSION OF TRAFFIC DURING EXECUTION OF THIS CONTRACT. HOWEVER, THE CONTRACTOR MAY MODIFY THE MOT PLANS TO MEET CONSTRUCTION NEEDS, BUT NOT AT THE EXPENSE OF PUBLIC SAFETY OR CONVENIENCE. ANY CHANGES TO THE MOT PLANS SHALL BE SUBMITTED TO THE ENGINEER FOR APPROVAL.
2. THE ENGINEER SHALL BE INFORMED 48 HOURS IN ADVANCE OF ANY PROPOSED CHANGE TO THE MOT PLANS.
3. ALL EXISTING PAVEMENT MARKINGS IN CONFLICT WITH THE MOT STRIPING SHALL BE REMOVED.
4. ALL TEMPORARY PAVEMENT MARKING WHICH CONFLICTS WITH THE NEXT STAGE OR FINAL STRIPING SHALL BE REMOVED.
5. ALL TRAFFIC CONTROL DEVICES USED FOR MOT, AS DETAILED IN THE PLANS OR HIGHWAY STANDARDS, SHALL BE REFLECTORIZED PRIOR TO INSTALLATION AND CLEANED AS SPECIFIED IN THE MOT SPECIAL PROVISIONS OR AS DIRECTED BY THE ENGINEER.
6. ALL EXISTING SIGNS WITHIN MOT LIMITS WHICH ARE OBSCURED BY OR CONFLICT WITH CONSTRUCTION OPERATIONS AND MOT, SHALL BE COVERED OR REMOVED BY THE CONTRACTOR UNLESS SPECIFIED IN THE PLANS OR WHEN DIRECTED BY THE ENGINEER. THIS WORK SHALL BE IN ACCORDANCE WITH ARTICLE 107.25 OF THE IDOT STANDARD SPECIFICATIONS.
7. A FULL DEPTH SAW CUT SHALL BE REQUIRED BETWEEN PAVEMENT, CURB AND / OR GUTTER TO REMAIN AND PAVEMENT, CURB AND / OR GUTTER TO BE REMOVED PRIOR TO BEGINNING OF REMOVAL WORK. COST TO BE INCLUDED WITH APPLICABLE REMOVAL ITEMS.

## GENERAL NOTES

1. **AGGREGATE FOR DRIVEWAY REPLACEMENT.** THE MATERIAL USED FOR CONSTRUCTION OF PERMANENT AGGREGATE DRIVEWAYS SHALL BE GRAVEL OR CRUSHED STONE, AS DIRECTED BY THE ENGINEER, TO REPLACE IN KIND THE EXISTING AGGREGATE DRIVEWAYS. NO ADDITIONAL COMPENSATION SHALL BE PROVIDED FOR THIS REQUIREMENT BUT SHALL BE CONSIDERED AS INCLUDED IN THE COST OF THE PAY ITEM FOR THE AGGREGATE AS SPECIFIED ON THE PLANS.
2. **BRIDGE OVERLAY NOTIFICATION.** AFTER PLACEMENT OF THE BRIDGE DECK OVERLAY, THE RESIDENT ENGINEER SHALL NOTIFY THE DISTRICT BRIDGE MAINTENANCE ENGINEER OF THE "AS CONSTRUCTED" MILLING DEPTH AND OVERLAY THICKNESS FOR UPDATING THE ILLINOIS HIGHWAY INFORMATION SYSTEM.
3. **BUTT JOINT CUTTING TIME RESTRICTION.** BUTT JOINTS SHALL NOT BE MILLED MORE THAN THREE (3) DAYS PRIOR TO PLACEMENT OF THE HMA SURFACE COURSE.
4. **SECURING DRAINAGE STRUCTURE GRATES.** PRIOR TO ROUTING TRAFFIC ONTO THE SHOULDERS AS SHOWN IN THE STAGING PLANS, THE CONTRACTOR SHALL SECURE GRATINGS ON SHOULDER INLETS AS DIRECTED BY THE ENGINEER. THIS WORK WILL NOT BE PAID FOR SEPARATELY, BUT SHALL BE INCLUDED IN THE COST OF THE TRAFFIC CONTROL PAY ITEM.
5. **NO PASSING ZONE VERIFICATION.** THE RESIDENT SHALL CONTACT OPERATIONS TO VERIFY THE LOCATION OF NO PASSING ZONES PRIOR TO PLACEMENT OF CENTERLINE STRIPING.
6. **PAVING SURFACE COURSE.** CONTINUOUS PAVING OPERATIONS ON THE MAIN ROADWAY SHALL BE MAINTAINED AT ALL TIMES DURING THE CONSTRUCTION OF THE HOT-MIX ASPHALT SURFACE. NO INTERRUPTIONS FOR SIDE ROADS, ENTRANCES, TURN LANES, ETC. WILL BE ALLOWED.

## COMMITMENTS

COMMITMENTS ARE NOT TO BE ALTERED WITHOUT THE WRITTEN APPROVAL OF ALL PARTIES TO WHICH THE COMMITMENT WAS MADE.

NO COMMITMENTS HAVE BEEN MADE ON THIS TIME.

## APPLICATION RATES

AGGREGATE SHOULDERS AND BASES: 0.05833 TON / SQ YD / INCH  
 HOT-MIX ASPHALT: 0.056 TON / SQ YD / INCH  
 GUARDRAIL AGGREGATE EROSION CONTROL: 1.5 TON / CU YD

POLYMERIZED BITUMINOUS (TACK COAT) RATES:  
 SURFACE TYPE                      RESIDUAL RATE  
 MILLED (HMA OR PCC)              0.08 LB/SQ FT  
 EXISTING PAVEMENT                0.08 LB/SQ FT  
 FOG COAT (BETWEEN LIFTS)        0.08 LB/SQ FT

## UTILITIES

NO UTILITY CONFLICTS HAVE BEEN FOUND WITHIN THE PROJECT LIMITS.  
 DIG RESPONSIBLY, CALL JULIE  
 UTILITIES LOCATED WITHIN THE ROW CONSIST OF:

AMEREN ELECTRIC, ADAM HOWARD  
 217-602-9381, AHOWARD2@AMAREN.COM

ATT TRANSMISSION, WILLIAM CONOVER  
 309-550-8043, WC2473@ATT.COM

THE FOLLOWING MIXTURE REQUIREMENTS ARE APPLICABLE FOR THIS PROJECT:

LOCATIONS:	MAINLINE	MAINLINE	SHOULDERS TOP LIFT	SHOULDERS TOP BINDER	SHOULDERS BOTTOM LIFT
MIXTURE USES:	POLYMER SURFACE 1.5"	POLYMER BINDER 1"	SURFACE 2"	BINDER LIFT 2"	LOWER LIFT 4"
AC/PC:	SBS OR SBR 70-28	SBS OR SBR 70-28	PG 58-28	PG 58-28	PG 58-28
DESIGN AIR VOIDS:	4% @ N = 70	4% @ N = 70	4% @ N = 50	4% @ N = 50	4% @ N = 50
MIX COMPOSITION: (GRADATION MIXTURE)	IL 9.5	IL 9.5	IL 9.5	IL 9.5	IL 19.0
FRICTION AGGREGATE:	MIXTURE "D"	NA	MIXTURE "C"	NA	NA
QUALITY MANAGEMENT:	QC/QA	QC/QA	QCQA	QCQA	QCQA
MTD (YES OR NO):	YES	YES	NO	NO	NO

PLAN QUANTITIES FOR BITUMINOUS CONCRETE SURFACE COURSE ITEMS ARE CALCULATED USING A UNIT WEIGHT OF 112 LBS/SQ YD / IN (59.8 KG/SQ M/25 MM THICKNESS)

## IDOT HIGHWAY STANDARDS

STD NO.	DESCRIPTION
000001-08	STANDARD SYMBOLS, ABBREVIATIONS AND PATTERNS
001006	DECIMAL OF AN INCH AND OF A FOOT
482001-02	HMA SHOULDER ADJACENT TO FLEXIBLE PAVEMENT
482011-03	HMA SHOULDER STRIPS/SHOULDERS WITH RESURFACING OR WIDENING AND RESURFACING PROJECTS
630001-13	STEEL PLATE BEAM GUARDRAIL
630301-09	SHOULDER WIDENING FOR TYPE 1 (SPECIAL) GUARDRAIL TERMINALS
631031-18	TRAFFIC BARRIER TERMINAL, TYPE 6
631033-09	TRAFFIC BARRIER TERMINAL, TYPE 6B
635001-02	DELINEATORS
701006-05	OFF-ROAD OPERATIONS, 2L, 2W, 15' (4.5 M) TO 24' (600 MM) FROM PAVEMENT EDGE
701011-04	OFF-ROAD MOVING OPERATIONS, 2L, 2W, DAY ONLY
701201-05	LANE CLOSURE, 2L, 2W, DAY ONLY, FOR SPEEDS > 45 MPH
701301-04	LANE CLOSURE, 2L, 2W, SHORT TIME OPERATIONS
701306-04	LANE CLOSURE, 2L, 2W, SLOW MOVING OPERATIONS DAY ONLY, FOR SPEEDS > 45 MPH
701311-03	LANE CLOSURE, 2L, 2W, MOVING OPERATIONS - DAY ONLY
701321-18	LANE CLOSURE, 2L, 2W, BRIDGE REPAIR WITH BARRIER
701326-04	LANE CLOSURE, 2L, 2W, PAVEMENT WIDENING, FOR SPEEDS > 45 MPH
701901-09	TRAFFIC CONTROL DEVICES
704001-08	TEMPORARY CONCRETE BARRIER
725001-01	OBJECT AND TERMINAL MARKERS
780001-05	TYPICAL PAVEMENT MARKINGS
781001-04	TYPICAL APPLICATIONS RAISED REFLECTIVE PAVEMENT MARKERS
782006-01	GUARDRAIL AND BARRIER WALL REFLECTOR MOUNTING DETAILS

MODEL: Unsaved (Rev. 1) Sheet 1  
 FILE NAME: S:\2023\2121009\_PTB\_202303\_04 - Hurst Bridge Repair Plans - Various PH1 & IIVC2s Bridge Repair Plans - 68H20CADD\000\_SheetSet\68H20CADD\68H20CADD.dgn



USER NAME = rgoertz	DESIGNED - RG	REVISED -
PLOT SCALE = 0.16666833' / in.	DRAWN - TO	REVISED -
PLOT DATE = 12/15/2023	CHECKED - SMK	REVISED -
	DATE -	REVISED -

**STATE OF ILLINOIS  
DEPARTMENT OF TRANSPORTATION**

GENERAL NOTES, INDEX OF SHEETS AND HIGHWAY STANDARDS			
SCALE: NONE	SHEET 1	OF 1 SHEETS	STA. TO STA.

F.A.P. RTE.	SECTION	COUNTY	TOTAL SHEETS	SHEET NO.
315/30	1139,138(BC;BC-1)BR,BR-1BRR	FULTON	119	2
CONTRACT NO. 68H20				
ILLINOIS FED. AID PROJECT				

CODE NO.	ITEM	UNIT	TOTAL QUANTITY	CONSTRUCTION TYPE CODE			
				80% FEDERAL 20% STATE	80% FEDERAL 20% STATE	80% FEDERAL 20% STATE	80% FEDERAL 20% STATE
				BRIDGE	BRIDGE	BRIDGE	BRIDGE
				0047	0047	0047	0047
				S.N. 029-0012	S.N. 029-0055	S.N. 029-0056	S.N. 029-0021
20200600	EXCAVATING AND GRADING EXISTING SHOULDER	UNIT	36	10	10	9	7
30300112	AGGREGATE SUBGRADE IMPROVEMENT 12"	SQ YD	1,704	507	476	417	304
40200700	AGGREGATE SURFACE COURSE, TYPE A 8"	SQ YD	85			85	
40600290	BITUMINOUS MATERIALS (TACK COAT)	POUND	751	175	159	244	173
40600295	POLYMERIZED BITUMINOUS MATERIALS (TACK COAT)	POUND	608	90	78	78	362
40600370	LONGITUDINAL JOINT SEALANT	FOOT	467	60	60	60	287
40600982	HOT-MIX ASPHALT SURFACE REMOVAL - BUTT JOINT	SQ YD	954	254	214	214	272
40600990	TEMPORARY RAMP	SQ YD	162				162
40603208	POLYMERIZED HOT-MIX ASPHALT BINDER COURSE, IL-9.5, N70	TON	20				20
40604162	POLYMERIZED HOT-MIX ASPHALT SURFACE COURSE, IL-9.5, MIX "D", N70	TON	606	22	17	17	550
44000153	HOT-MIX ASPHALT SURFACE REMOVAL, 1"	SQ YD	343				343
48102100	AGGREGATE WEDGE SHOULDER, TYPE B	TON	2				2
48203029	HOT-MIX ASPHALT SHOULDERS, 8"	SQ YD	1,365	387	352	402	224
50102400	CONCRETE REMOVAL	CU YD	41.1	10.7	10.4	10.5	9.5

MODEL: S001\_S001 (Rev.1)  
 FILE NAME: S:\2023\2023\006 PTB 2023-01.D4 - Hurst Roache - Various PH1 & IIVC2 Bridge Repair Plans 68H20\CAD\CADD\_Sheet\0468H20-11-S001.dgn



USER NAME = rgoertz  
 PLOT SCALE = 0.16666633' / in.  
 PLOT DATE = 12/15/2023

DESIGNED - RG  
 DRAWN - TO  
 CHECKED - SMK  
 DATE -

REVISED -  
 REVISED -  
 REVISED -  
 REVISED -

**STATE OF ILLINOIS  
 DEPARTMENT OF TRANSPORTATION**

**SUMMARY OF QUANTITIES  
 US 136 & IL 78 /97**

SCALE: NONE    SHEET 1 OF 5 SHEETS    STA.    TO STA.

F.A.P. RTE.	SECTION	COUNTY	TOTAL SHEETS	SHEET NO.
315/30	1139,138(BC;BC-1)BR,BR-1 BRR	FULTON	119	3
CONTRACT NO. 68H20				
ILLINOIS FED. AID PROJECT				

CODE NO.	ITEM	UNIT	TOTAL QUANTITY	CONSTRUCTION TYPE CODE			
				80% FEDERAL 20% STATE	80% FEDERAL 20% STATE	80% FEDERAL 20% STATE	80% FEDERAL 20% STATE
				BRIDGE	BRIDGE	BRIDGE	BRIDGE
				0047	0047	0047	0047
				S.N. 029-0012	S.N. 029-0055	S.N. 029-0056	S.N. 029-0021
50300255	CONCRETE SUPERSTRUCTURE	CU YD	45.2	12.0	11.4	11.4	10.4
50300260	BRIDGE DECK GROOVING	SQ YD	5,320	1,107	1,431	2,101	681
50300300	PROTECTIVE COAT	SQ YD	5,688	1,182	1,531	2,246	729
50800205	REINFORCEMENT BARS, EPOXY COATED	POUND	6,660	1,800	1,600	1,600	1,660
50800515	BAR SPLICERS	EACH	104	26	26	26	26
52000110	PREFORMED JOINT STRIP SEAL	FOOT	278	76	68	68	66
59300100	CONTROLLED LOW-STRENGTH MATERIAL	CU YD	10				10
60260100	INLETS TO BE ADJUSTED	EACH	12		4	4	4
* 63000001	STEEL PLATE BEAM GUARDRAIL, TYPE A, 6 FOOT POSTS	FOOT	1187.5	262.5	450.0		475.0
* 63100085	TRAFFIC BARRIER TERMINAL, TYPE 6	EACH	12		4	4	4
* 63100089	TRAFFIC BARRIER TERMINAL, TYPE 6B	EACH	4	4			
* 63100167	TRAFFIC BARRIER TERMINAL, TYPE 1 (SPECIAL) TANGENT	EACH	1		1		
* 63100169	TRAFFIC BARRIER TERMINAL, TYPE 1 (SPECIAL) FLARED	EACH	2	2			
63200310	GUARDRAIL REMOVAL	FOOT	2,210	533	728	266	683

\*= SPECIALTY ITEM

MODEL: S001\_S002 (Rev.4)  
 FILE NAME: S:\2023\1006\_PTB 2005-30 DA - Hurst Roache - Various PH1 & IIVC2 Bridge Repair Plans 68H20\CADD\CADD\_Sheet\68H20-1H-S002.dgn



USER NAME = rgoertz  
 PLOT SCALE = 0.16666833' / in.  
 PLOT DATE = 12/15/2023

DESIGNED - RG  
 DRAWN - TO  
 CHECKED - SMK  
 DATE -

REVISED -  
 REVISED -  
 REVISED -  
 REVISED -

STATE OF ILLINOIS  
DEPARTMENT OF TRANSPORTATION

SUMMARY OF QUANTITIES  
US 136 & IL 78 /97

SCALE: NONE SHEET 2 OF 5 SHEETS STA. TO STA.

F.A.P. RTE.	SECTION	COUNTY	TOTAL SHEETS	SHEET NO.
315/30	1139,138(BC;BC-1)BR,BR-1BRR	FULTON	119	4
CONTRACT NO. 68H20				
ILLINOIS FED. AID PROJECT				

CODE NO.	ITEM	UNIT	TOTAL QUANTITY	CONSTRUCTION TYPE CODE			
				80% FEDERAL 20% STATE	80% FEDERAL 20% STATE	80% FEDERAL 20% STATE	80% FEDERAL 20% STATE
				BRIDGE	BRIDGE	BRIDGE	BRIDGE
				0047	0047	0047	0047
				S.N. 029-0012	S.N. 029-0055	S.N. 029-0056	S.N. 029-0021
67000400	ENGINEER'S FIELD OFFICE, TYPE A	CAL MO	16	4	4	4	4
67100100	MOBILIZATION	L SUM	1.00	0.25	0.25	0.25	0.25
70100405	TRAFFIC CONTROL AND PROTECTION, STANDARD 701321	EACH	4	1	1	1	1
70100450	TRAFFIC CONTROL AND PROTECTION, STANDARD 701201	L SUM	1.00	0.25	0.25	0.25	0.25
70100460	TRAFFIC CONTROL AND PROTECTION, STANDARD 701306	L SUM	1.00	0.25	0.25	0.25	0.25
70100500	TRAFFIC CONTROL AND PROTECTION, STANDARD 701326	L SUM	1.00	0.25	0.25	0.25	0.25
70103815	TRAFFIC CONTROL SURVEILLANCE	CAL DA	70.0	17.5	17.5	17.5	17.5
70106500	TEMPORARY BRIDGE TRAFFIC SIGNALS	EACH	4	1	1	1	1
70106700	TEMPORARY RUMBLE STRIPS	EACH	27	6	6	6	9
70107025	CHANGEABLE MESSAGE SIGN	CAL DA	56	14	14	14	14
70300100	SHORT TERM PAVEMENT MARKING	FOOT	1,533				1,533
70300150	SHORT TERM PAVEMENT MARKING REMOVAL	SQ FT	5,993	1,309	1,406	1,734	1,544
70307120	TEMPORARY PAVEMENT MARKING - LINE 4" - TYPE IV TAPE	FOOT	15,146	3,637	3,928	4,914	2,667
70307210	TEMPORARY PAVEMENT MARKING - LINE 24" - TYPE IV TAPE	FOOT	216	48	48	48	72

MODEL: S001\_S003 (Rev.4)  
 FILE NAME: S:\2023\23006 PTB 2025-30 DA - Hurst Rosche - Various PH1 & IIVC2 Bridge Repair Plans 68H20CADD\CADD\_Sheet\DA68H20-4H-S003.dgn



USER NAME = rgoertz  
 PLOT SCALE = 0.166666833' / in.  
 PLOT DATE = 12/15/2023

DESIGNED - RG  
 DRAWN - TO  
 CHECKED - SMK  
 DATE -

REVISED -  
 REVISED -  
 REVISED -  
 REVISED -

**STATE OF ILLINOIS  
 DEPARTMENT OF TRANSPORTATION**

**SUMMARY OF QUANTITIES  
 US 136 & IL 78 /97**

SCALE: NONE    SHEET 3 OF 5 SHEETS    STA.    TO STA.

F.A.P. RTE.	SECTION	COUNTY	TOTAL SHEETS	SHEET NO.
315/30	1139,138(BC;BC-1)BR, BR-1BRR	FULTON	119	5
CONTRACT NO. 68H20				
ILLINOIS		FED. AID PROJECT		

CODE NO.	ITEM	UNIT	TOTAL QUANTITY	CONSTRUCTION TYPE CODE			
				80% FEDERAL 20% STATE	80% FEDERAL 20% STATE	80% FEDERAL 20% STATE	80% FEDERAL 20% STATE
				BRIDGE	BRIDGE	BRIDGE	BRIDGE
				0047	0047	0047	0047
				S.N. 029-0012	S.N. 029-0055	S.N. 029-0056	S.N. 029-0021
70400100	TEMPORARY CONCRETE BARRIER	FOOT	2,850.00	650.00	737.50	925.00	537.50
70400200	RELOCATE TEMPORARY CONCRETE BARRIER	FOOT	2,850.00	650.00	762.50	950.00	487.50
70600251	IMPACT ATTENUATORS, TEMPORARY (NON- REDIRECTIVE, NARROW), TEST LEVEL 3	EACH	12	2	2	6	2
70600352	IMPACT ATTENUATORS, RELOCATE (NON- REDIRECTIVE,NARROW), TEST LEVEL 3	EACH	10	2	2	4	2
* 72501000	TERMINAL MARKER - DIRECT APPLIED	EACH	3	2	1		
* 78009004	MODIFIED URETHANE PAVEMENT MARKING - LINE 4"	FOOT	11,824	2,274	2,700	3,893	2,957
* 78009024	MODIFIED URETHANE PAVEMENT MARKING - LINE 24"	FOOT	12				12
* 78100100	RAISED REFLECTIVE PAVEMENT MARKER	EACH	49	8	10	11	20
* 78200011	BARRIER WALL REFLECTORS, TYPE C	EACH	71	12	20	30	9
78300200	RAISED REFLECTIVE PAVEMENT MARKER REMOVAL	EACH	49	8	10	11	20
78300202	PAVEMENT MARKING REMOVAL - WATER BLASTING	SQ FT	5,237	1,011	1,200	1,873	1,153
* X6330725	STEEL PLATE BEAM GUARDRAIL (SHORT RADIUS)	FOOT	125.0		25.0	100.0	
X6350204	LINEAR DELINEATOR PANELS, 4 INCH	EACH	64	16	16	16	16
Z0001002	GUARDRAIL AGGREGATE EROSION CONTROL	TON	566	107	203	71	185

\* = SPECIALTY ITEM

MODEL: S001\_S00M (Rev.1)  
FILE NAME: S:\2023\2023\006\_PTB 2023-01.D4 - Hurst Roache - Various PH1 & IJWC2 Bridge Repair Plans 68H20CADD\CADD\_Sheet\0468H20-4H-S00.dgn



USER NAME = rgoertz  
DESIGNED - RG  
DRAWN - TO  
PLOT SCALE = 0.16666633' / in.  
CHECKED - SMK  
PLOT DATE = 12/15/2023  
DATE -

REVISED -  
REVISED -  
REVISED -  
REVISED -

**STATE OF ILLINOIS  
DEPARTMENT OF TRANSPORTATION**

**SUMMARY OF QUANTITIES  
US 136 & IL 78 / 97**  
SCALE: NONE SHEET 4 OF 5 SHEETS STA. TO STA.

F.A.P. RTE.	SECTION	COUNTY	TOTAL SHEETS	SHEET NO.
315/30	1139,138(BC;BC-1)BR,BR-1BRR	FULTON	119	6
CONTRACT NO. 68H20				
ILLINOIS FED. AID PROJECT				

MODEL: S001\_S002.rvt  
 FILE NAME: S:\2023\2023\008\_PTB\_2023-01-D4 - Hurst Rosche - Various PH1 & IJWC2 Bridge Repair Plans\_68H20CADD\CADD\_Sheet\0468H20-04-S002.dgn

CODE NO.	ITEM	UNIT	TOTAL QUANTITY	CONSTRUCTION TYPE CODE			
				80% FEDERAL 20% STATE	80% FEDERAL 20% STATE	80% FEDERAL 20% STATE	80% FEDERAL 20% STATE
				BRIDGE	BRIDGE	BRIDGE	BRIDGE
				0047	0047	0047	0047
				S.N. 029-0012	S.N. 029-0055	S.N. 029-0056	S.N. 029-0021
Z0001905	STRUCTURAL STEEL REPAIR	POUND	2,270	860	390	960	60
Z0004544	HOT-MIX ASPHALT DRIVEWAY PAVEMENT REMOVAL	SQ YD	108			108	
Z0012130	BRIDGE DECK SCARIFICATION 3/4"	SQ YD	5,578	1,153	1,504	2,219	702
Z0012162	BRIDGE DECK MICROSILICA CONCRETE OVERLAY 2 1/4"	SQ YD	5,578	1,153	1,504	2,219	702
Z0012754	STRUCTURAL REPAIR OF CONCRETE (DEPTH EQUAL TO OR LESS THAN 5 INCHES)	SQ FT	109	13	65	25	6
Z0013798	CONSTRUCTION LAYOUT	L SUM	1.00	0.25	0.25	0.25	0.25
Z0016001	DECK SLAB REPAIR (FULL DEPTH, TYPE I)	SQ YD	5		2	3	
Z0016002	DECK SLAB REPAIR (FULL DEPTH, TYPE II)	SQ YD	8		4	2	2
Z0018051	DRAINAGE SCUPPERS TO BE ADJUSTED	EACH	8		4	4	
Z0034105	MATERIAL TRANSFER DEVICE	TON	626	22	17	17	570
Ø Z0076600	TRAINEES	HOUR	1,000	1,000			
Z0065730	SLOPE WALL SLURRY PUMPING	CU YD	10				10
Ø Z0076604	TRAINEES - TRAINING PROGRAM GRADUATE	HOUR	1,000	1,000			

Ø 0042



USER NAME = rgoertz  
 PLOT SCALE = 0.16666633' / in.  
 PLOT DATE = 12/15/2023

DESIGNED - RG  
 DRAWN - TO  
 CHECKED - SMK  
 DATE -

REVISED -  
 REVISED -  
 REVISED -  
 REVISED -

STATE OF ILLINOIS  
DEPARTMENT OF TRANSPORTATION

SUMMARY OF QUANTITIES  
US 136 & IL 78 / 97

SCALE: NONE SHEET 5 OF 5 SHEETS STA. TO STA.

F.A.P. RTE.	SECTION	COUNTY	TOTAL SHEETS	SHEET NO.
315/30	1139,138(BC;BC-1)BR,BR-1BRR	FULTON	119	7
CONTRACT NO. 68H20				
ILLINOIS FED. AID PROJECT				

**PAVING SCHEDULE**

LOCATION			EXCAVATING AND GRADING EXISTING SHOULDER 20200600 (UNIT)	AGGREGATE SUBGRADE IMPROVEMENT 12" 30300112 (SQ YD)	AGGREGATE SURFACE COURSE, TYPE A 8" 40200700 (SQ YD)	BITUMINOUS MATERIALS (TACK COAT) 40600290 (POUND)	POLYMERIZED BITUMINOUS MATERIALS (TACK COAT) 40600295 (POUND)	LONGITUDINAL JOINT SEALANT 40600370 (FOOT)	HOT-MIX ASPHALT SURFACE REMOVAL - BUTT JOINT 40600982 (SQ YD)	TEMPORARY RAMP 40600990 (SQ YD)	POLYMERIZED HOT-MIX ASPHALT BINDER COURSE, IL-9.5, N70 40603208 (TON)	POLYMERIZED HOT-MIX ASPHALT SURFACE COURSE, IL-9.5, MIX "D", N70 40604162 (TON)	HOT-MIX ASPHALT SURFACE REMOVAL, 1" 44000153 (SQ YD)	AGGREGATE WEDGE SHOULDER, TYPE B 48102100 (TON)	HOT-MIX ASPHALT SHOULDERS, 8" 48203029 (SQ YD)	GUARDRAIL AGGREGATE EROSION CONTROL Z0001002 (TON)	HOT-MIX ASPHALT DRIVEWAY PAVEMENT Z0004544 (SQ YD)	MATERIAL TRANSFER DEVICE Z0034105 (TON)	
<b>SN 029-0012 (US 136)</b>																			
321+30.00	323+58.10	LT	2.28	126.98		43.80									97.32	30.78			
321+30.00	323+58.10	RT	2.28	131.79		45.96									102.14	36.59			
326+51.12	328+85.00	LT	2.34	121.10		40.81									90.69	14.68			
326+51.12	328+85.00	RT	2.34	127.07		43.50									96.67	14.66			
323+28.10	323+58.10	LT / RT					45.00	30.00	126.67			10.86							
326+51.12	326+81.12	LT / RT					45.00	30.00	126.67			11.02							21.88
<b>SUBTOTAL</b>			<b>9.24</b>	<b>506.94</b>		<b>174.07</b>	<b>90.00</b>	<b>60.00</b>	<b>253.34</b>			<b>21.88</b>			<b>386.82</b>	<b>96.71</b>			<b>21.88</b>
<b>USE</b>			<b>10</b>	<b>507</b>		<b>175</b>	<b>90</b>	<b>60</b>	<b>254</b>			<b>22</b>			<b>387</b>	<b>107</b>			<b>22</b>
<b>SN 029-0055 (IL 78 / IL 97)</b>																			
488+45.00	490+85.38	LT	2.4	120.19		40.02									88.94	15.17			
488+45.00	490+85.38	RT	2.4	120.19		40.02									88.94	56.76			
495+14.77	497+50.00	LT	2.35	117.62		39.17									87.04	55.48			
495+14.77	497+50.00	RT	2.35	117.62		39.17									87.04	56.31			
490+55.38	490+85.38	LT / RT					39.00	30.00	106.67			8.44							
495+14.77	495+44.77	LT / RT					39.00	30.00	106.67			8.44							16.88
<b>SUBTOTAL</b>			<b>9.50</b>	<b>475.62</b>		<b>158.38</b>	<b>78.00</b>	<b>60.00</b>	<b>213.34</b>			<b>16.88</b>			<b>351.96</b>	<b>183.72</b>			<b>16.88</b>
<b>USE</b>			<b>10</b>	<b>476</b>		<b>159</b>	<b>78</b>	<b>60</b>	<b>214</b>			<b>17</b>			<b>352</b>	<b>203</b>			<b>17</b>
<b>SN 029-0056 (IL 78 / IL 97)</b>																			
502+60.00	504+12.08	LT	1.52	77.08		25.67									57.04	15.64			
504+55.79	504+95.70	LT	0.4	4.00		12.78									14.2				
502+60.00	504+95.70	RT	2.36	19.19		78.49									87.21	16.42			
511+26.92	511+67.41	LT	0.4	117.85		13.04									14.49	16.18			
512+15.81	513+60.00	LT	1.44	19.58		50.17									55.74				
511+26.92	511+67.60	RT	0.41	75.33		13.55									15.05	15.98			
512+12.29	513+60.00	RT	1.48	20.34		49.81									55.35				
504+35.52		LT		4.00	23.94										34.07			32.22	
511+90.24		RT		4.00	34.22										34.07			34.67	
511+90.56		LT		74.79	26.32										34.07			40.22	
504+65.70	504+95.70	LT / RT					39.00	30.00	106.67			8.44							
511+26.92	511+56.92	LT / RT					39.00	30.00	106.67			8.44							16.88
<b>SUBTOTAL</b>			<b>8.01</b>	<b>416.16</b>	<b>84.48</b>	<b>243.51</b>	<b>78.00</b>	<b>60.00</b>	<b>213.34</b>			<b>16.88</b>			<b>401.29</b>	<b>64.22</b>	<b>107.11</b>		<b>16.88</b>
<b>USE</b>			<b>9</b>	<b>417</b>	<b>85</b>	<b>244</b>	<b>78</b>	<b>60</b>	<b>214</b>			<b>17</b>			<b>402</b>	<b>71</b>	<b>108</b>		<b>17</b>
<b>SN 029-0021 (IL 78 / IL 97)</b>																			
532+30.00	534+79.37	LT	2.49	124.69		83.04									92.27	53.31			
532+30.00	534+79.37	RT	2.49	124.69		83.04									92.27	53.8			
536+87.06	537+50.00	LT	0.63	27.79		3.90									19.63	32.29			
536+87.06	537+40.00	RT	0.53	26.13		2.79									19.27	28.41			
534+49.37	534+79.37	LT / RT					39.00	30.00	106.67			8.44							19.86
536+87.06	538+14.75	LT / RT					322.97	257.00	165.01	162.00	19.86	541.13	342.72	1.99					549.57
<b>SUBTOTAL</b>			<b>6.14</b>	<b>303.3</b>		<b>172.77</b>	<b>361.97</b>	<b>287.00</b>	<b>271.68</b>	<b>162.00</b>	<b>19.86</b>	<b>549.57</b>	<b>342.72</b>	<b>1.99</b>	<b>223.44</b>	<b>167.81</b>			<b>569.43</b>
<b>USE</b>			<b>7</b>	<b>304</b>		<b>173</b>	<b>362</b>	<b>287</b>	<b>272</b>	<b>162</b>	<b>20</b>	<b>550</b>	<b>343</b>	<b>2</b>	<b>224</b>	<b>185</b>			<b>570</b>
<b>GRAND TOTALS</b>			<b>36</b>	<b>1,704</b>	<b>85</b>	<b>751</b>	<b>608</b>	<b>467</b>	<b>954</b>	<b>162</b>	<b>20</b>	<b>606</b>	<b>343</b>	<b>2</b>	<b>1,365</b>	<b>566</b>	<b>108</b>		<b>626</b>

MODEL: Unnamed (Rev: 1) - Plot: 0 (Rev: 1)  
 FILE NAME: S:\2023\231106\PTB 2023\01 - Hurst Rosche - Various PH1 & ILLINOIS Bridge Repair Plans 68H20CADDD\CADD\_Sheet\0468H20CADDD-04-01.dwg



USER NAME = rgoertz  
 PLOT SCALE = 0.16666833 / in.  
 PLOT DATE = 12/15/2023

DESIGNED - RG	REVISED -
DRAWN - TO	REVISED -
CHECKED - SMK	REVISED -
DATE -	REVISED -

**STATE OF ILLINOIS**  
**DEPARTMENT OF TRANSPORTATION**

**SCHEDULE OF QUANTITIES**  
**US 136 & IL 78 / 97**

SCALE: NONE    SHEET 1 OF 3 SHEETS    STA.    TO STA.

F.A.P. RTE.	SECTION	COUNTY	TOTAL SHEETS	SHEET NO.
315/30	1139,138(BC-1)BR, BR-1(BRR)	FULTON	119	8
CONTRACT NO. 68H20				
ILLINOIS FED. AID PROJECT				



**GUARDRAIL SCHEDULE**

LOCATION			STEEL PLATE BEAM GUARDRAIL, TYPE A, 6 FOOT POSTS 63000001 (FOOT)	TRAFFIC BARRIER TERMINAL, TYPE 6 63100085 (EACH)	TRAFFIC BARRIER TERMINAL, TYPE 6B 63100089 (EACH)	TRAFFIC BARRIER TERMINAL, TYPE 1 (SPECIAL) TANGENT 63100167 (EACH)	TRAFFIC BARRIER TERMINAL, TYPE 1 (SPECIAL) FLARED 63100169 (EACH)	GUARDRAIL REMOVAL 63200310 (FOOT)	TERMINAL MARKER - DIRECT APPLIED 72501000 (EACH)	STEEL PLATE BEAM GUARDRAIL (SHORT RADIUS) X6330725 (FOOT)	LINEAR DELINEATOR PANELS, 4 INCH X6350204 (EACH)
STA	STA	LT / RT									
<b>SN 029-0012 (US 136)</b>											
322+91.76	323+41.76	LT	50.0								4
322+29.49	323+41.99	RT	112.5								4
326+67.21	327+17.21	LT	50.0								4
326+66.95	327+16.97	RT	50.0								4
323+41.76	323+78.66	LT			1						
323+41.99	323+78.89	RT			1						
326+30.31	326+67.21	LT			1						
326+30.05	326+66.95	RT			1						
322+41.93	322+91.76	LT					1		1		
321+79.65	322+29.49	RT					1		1		
322+44.93	323+85.82	LT						140.89			
321+82.01	323+85.73	RT						203.72			
326+23.37	327+17.21	LT						93.84			
326+23.09	327+16.97	RT						93.88			
<b>SUBTOTAL</b>			<b>262.5</b>	<b>0</b>	<b>4</b>	<b>0</b>	<b>2</b>	<b>532.33</b>	<b>2</b>	<b>0.0</b>	<b>16</b>
<b>USE</b>			<b>262.5</b>	<b>0</b>	<b>4</b>	<b>0</b>	<b>2</b>	<b>533</b>	<b>2</b>	<b>0.0</b>	<b>16</b>
<b>SN 029-0055 (IL 78 / IL 97)</b>											
489+31.21	490+56.15	RT	125.0								4
495+44.50	497+06.91	LT	162.5								4
495+44.00	497+06.96	RT	162.5								4
490+55.91	490+92.81	LT		1							
490+56.15	490+93.05	RT		1							
495+07.60	495+44.50	LT		1							
495+07.10	495+44.00	RT		1							4
488+81.22	489+31.21	LT				1			1		
490+44.15	491+09.94	LT						65.79			
488+80.26	491+09.60	RT						229.34			
494+90.57	497+06.91	LT						216.34			
494+90.82	497+06.96	RT						216.14			
490+38.99	490+55.91	LT								25.0	
<b>SUBTOTAL</b>			<b>450.0</b>	<b>4</b>	<b>0</b>	<b>1</b>	<b>0</b>	<b>727.61</b>	<b>1</b>	<b>25.0</b>	<b>16</b>
<b>USE</b>			<b>450.0</b>	<b>4</b>	<b>0</b>	<b>1</b>	<b>0</b>	<b>728</b>	<b>1</b>	<b>25.0</b>	<b>16</b>
<b>SN 029-0056 (IL 78 / IL 97)</b>											
504+66.42	505+03.32	LT		1							4
504+66.49	505+03.39	RT		1							4
511+19.38	511+56.28	LT		1							4
511+19.29	511+56.19	RT		1							4
504+53.08	505+19.14	LT						66.06			
504+52.89	505+19.42	RT						66.53			
511+03.29	511+70.11	LT						66.82			
511+03.25	511+69.40	RT						66.15			
504+47.44	504+66.42	LT								25.0	
504+49.57	504+66.49	RT								25.0	
511+56.28	511+69.95	LT								25.0	
511+56.19	511+70.61	RT								25.0	
<b>SUBTOTAL</b>			<b>0.0</b>	<b>4</b>	<b>0</b>	<b>0</b>	<b>0</b>	<b>265.56</b>	<b>0</b>	<b>100.0</b>	<b>16</b>
<b>USE</b>			<b>0.0</b>	<b>4</b>	<b>0</b>	<b>0</b>	<b>0</b>	<b>266</b>	<b>0</b>	<b>100.0</b>	<b>16</b>
<b>SN 029-0021 (IL 78 / IL 97)</b>											
532+88.58	534+63.55	LT	175.0								4
532+88.62	534+63.60	RT	175.0								4
537+01.98	537+59.65	LT	62.5								4
537+03.26	537+68.10	RT	62.5								4
534+63.55	535+00.45	LT		1							
534+63.60	535+00.50	RT		1							
536+65.64	537+01.98	LT		1							
536+65.77	537+03.26	RT		1							
532+88.58	535+15.91	LT						227.33			
532+88.62	535+16.16	RT						227.54			
536+50.08	537+59.65	LT						109.57			
536+50.01	537+68.10	RT						118.09			
<b>SUBTOTAL</b>			<b>475.0</b>	<b>4</b>	<b>0</b>	<b>0</b>	<b>0</b>	<b>682.53</b>	<b>0</b>	<b>0.0</b>	<b>16</b>
<b>USE</b>			<b>475.0</b>	<b>4</b>	<b>0</b>	<b>0</b>	<b>0</b>	<b>683</b>	<b>0</b>	<b>0.0</b>	<b>16</b>
<b>GRAND TOTALS</b>			<b>1,187.5</b>	<b>12</b>	<b>4</b>	<b>1</b>	<b>2</b>	<b>2,210</b>	<b>3</b>	<b>125.0</b>	<b>64</b>

MODEL: Unnamed (1) - 2 - Plan - 0 (Rev) / FILE NAME: S:\2023\211009\PTB 202303.Dwg - Hurst Roache - Various PH1 & IJWCs Bridge Repair Plans 68H20CADD\CADD\_Sheet\68H20CADD\68H20CADD.dwg



USER NAME = rgoertz	DESIGNED - RG	REVISED -
PLOT SCALE = 0.16666833' / in.	DRAWN - TO	REVISED -
PLOT DATE = 12/15/2023	CHECKED - SMK	REVISED -
	DATE -	REVISED -

**STATE OF ILLINOIS**  
**DEPARTMENT OF TRANSPORTATION**

<b>SCHEDULE OF QUANTITIES</b>			
<b>US 136 &amp; IL 78 / 97</b>			
SCALE: NONE	SHEET 2	OF 3 SHEETS	STA. TO STA.

F.A.P. RTE. 315/30	SECTION 1139.138(BC,BC-1)BR, BR-1(BRR)	COUNTY FULTON	TOTAL SHEETS 119	SHEET NO. 9
CONTRACT NO. 68H20				
ILLINOIS FED. AID PROJECT				

TEMPORARY SIGNAL SCHEDULE	
LOCATION	TEMPORARY BRIDGE TRAFFIC SIGNALS
	70106500 (EACH)
SN 029-0012 (US 136) (COVERS STAGE I & II)	1
SN 029-0055 (IL 78 / IL 97) (COVERS STAGE I & II)	1
SN 029-0056 (IL 78 / IL 97) (COVERS STAGE I & II)	1
SN 029-0021 (IL 78 / IL 97) (COVERS STAGE I & II)	1
<b>TOTAL</b>	<b>4</b>

PAVEMENT MARKING SCHEDULE											
LOCATION			SHORT TERM PAVEMENT MARKING	SHORT TERM PAVEMENT MARKING REMOVAL	TEMPORARY PAVEMENT MARKING - LINE 4" - TYPE IV TAPE	TEMPORARY PAVEMENT MARKING - LINE 24" - TYPE IV TAPE	MODIFIED URETHANE PAVEMENT MARKING - LINE 4"	MODIFIED URETHANE PAVEMENT MARKING - LINE 24"	RAISED REFLECTIVE PAVEMENT MARKER	RAISED REFLECTIVE PAVEMENT MARKER REMOVAL	PAVEMENT MARKING REMOVAL - WATER BLASTING
STA	STA	LT / RT	70300100 (FOOT)	70300150 (SQ FT)	70307120 (FOOT)	70307210 (FOOT)	78009004 (FOOT)	78009024 (FOOT)	78100100 (EACH)	78300200 (EACH)	78300202 (SQ FT)
SN 029-0012 (US 136)											
319+95.08	330+05.35	LT / RT		1308.33	3636.83	48.00	2273.11		8	8	1,010.25
SUBTOTAL				1308.33	3,636.83	48.00	2,273.11		8	8	1,010.25
USE				1309	3,637	48	2,274		8	8	1,011
SN 029-0055 (IL 78 / IL 97)											
486+65.00	498+64.77	LT / RT		1405.33	3927.09	48.00	2,699.48		10	10	1,199.76
SUBTOTAL				1405.33	3,927.09	48.00	2,699.48		10	10	1,199.76
USE				1406	3,928	48	2,700		10	10	1,200
SN 029-0056 (IL 78 / IL 97)											
500+76.00	515+26.67	LT / RT		1734.00	4913.30	48.00	3892.17		11	11	1,872.90
SUBTOTAL				1734.00	4,913.30	48.00	3,892.17		11	11	1,872.90
USE				1734	4,914	48	3,893		11	11	1,873
SN 029-0021 (IL 78 / IL 97)											
531+25.19	539+20.01	LT / RT	1532.28	1544.00	2666.27	72.00	2956.37	12.00	20	20	1,152.65
SUBTOTAL			1,532.28	1544.00	2,666.27	72.00	2,956.37	12.00	20	20	1,152.65
USE			1,533	1544	2,667	72	2,957	12	20	20	1,153
<b>GRAND TOTALS</b>			<b>1,533</b>	<b>5,993</b>	<b>15,146</b>	<b>216</b>	<b>11,824</b>	<b>12</b>	<b>49</b>	<b>49</b>	<b>5,237</b>

PARAPET REFLECTOR SCHEDULE			
LOCATION			BARRIER WALL REFLECTORS, TYPE C
			78200011 (EACH)
SN 029-0012 (US 136)			
323+88.30	326+20.80	LT / RT	12
SUBTOTAL			12
SN 029-0055 (IL 78 / IL 97)			
491+04.75	494+95.25	LT / RT	20
SUBTOTAL			20
SN 029-0056 (IL 78 / IL 97)			
505+15.50	511+07.25	LT / RT	30
SUBTOTAL			30
SN 029-0021 (IL 78 / IL 97)			
534+98.88	536+67.40	LT / RT	9
SUBTOTAL			9
<b>GRAND TOTALS</b>			<b>71</b>

TEMPORARY CONCRETE BARRIER SCHEDULE						
LOCATION			TEMPORARY CONCRETE BARRIER	RELOCATE TEMPORARY CONCRETE BARRIER	IMPACT ATTENUATORS, TEMPORARY (NON-REDIRECTIVE, NARROW), TEST LEVEL 3	IMPACT ATTENUATORS, RELOCATE (NON-REDIRECTIVE, NARROW), TEST LEVEL 3
			70400100 (FOOT)	70400200 (FOOT)	70600251 (EACH)	70600352 (EACH)
SN 029-0012 (US 136)						
321+89.78	328+34.82	LT / RT	650.00	650.00	2	2
SUBTOTAL			650.00	650.00	2	2
SN 029-0055 (IL 78 / IL 97)						
488+52.32	496+76.11	LT / RT	737.50	762.50	2	2
SUBTOTAL			737.50	762.50	2	2
SN 029-0056 (IL 78 / IL 97)						
502+62.33	513+66.10	LT / RT	925.00	950.00	6	4
SUBTOTAL			925.00	950.00	6	4
SN 029-0021 (IL 78 / IL 97)						
533+11.04	538+07.06	LT / RT	537.50	487.50	2	2
SUBTOTAL			537.50	487.50	2	2
<b>GRAND TOTALS</b>			<b>2,850.00</b>	<b>2,850.00</b>	<b>12</b>	<b>10</b>

MODEL: Unsaved (Rev. 3) - Plot - 1 (Rev. 1)  
 FILE NAME: S:\2023\2311\06\PTB 2023-01.Dwg - Hurst Roache - Various PH1 & IJWC2 Bridge Repair Plans 68H20\ADD\CADD\_Sheet\0468H20-04-Technical.dwg



USER NAME = rgoertz  
 PLOT SCALE = 0.16666833 / in.  
 PLOT DATE = 12/15/2023

DESIGNED - RG  
 DRAWN - TO  
 CHECKED - SMK  
 DATE -

REVISED -  
 REVISED -  
 REVISED -  
 REVISED -

STATE OF ILLINOIS  
 DEPARTMENT OF TRANSPORTATION

**SCHEDULE OF QUANTITIES**  
**US 136 & IL 78 / 97**  
 SCALE: NONE SHEET 3 OF 3 SHEETS STA. TO STA.

F.A.P. RTE.	SECTION	COUNTY	TOTAL SHEETS	SHEET NO.
315/30	1139,138(BC;BC-1)BR, BR-1BRR	FULTON	119	10
CONTRACT NO. 68H20				
ILLINOIS FED. AID PROJECT				

**LEGEND**

- (A) EX PCC PAVEMENT
- (B) EX HMA OVERLAY, 3"
- (C) EX HMA SHOULDERS, 8"
- (D) EX AGGREGATE SHOULDERS
- (E) EX LEVELING BINDER (VAR 0"-5¼")
- (F) EX HMA SURFACE COURSE, 1½"
- (G) EX AGGREGATE SHOULDERS (VAR 0"-6¾")
- (H) EX HMA SHOULDER WIDENING, 8"

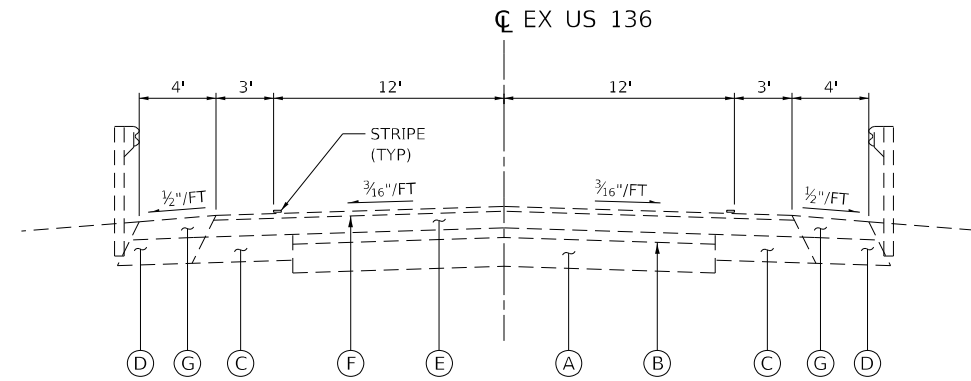

**EXISTING TYPICAL SECTION**

STA 322+00 TO STA 322+58  
 STA 327+62 TO STA 328+07  
 BRIDGE OMISSION: STA 323+58 TO STA 326+62

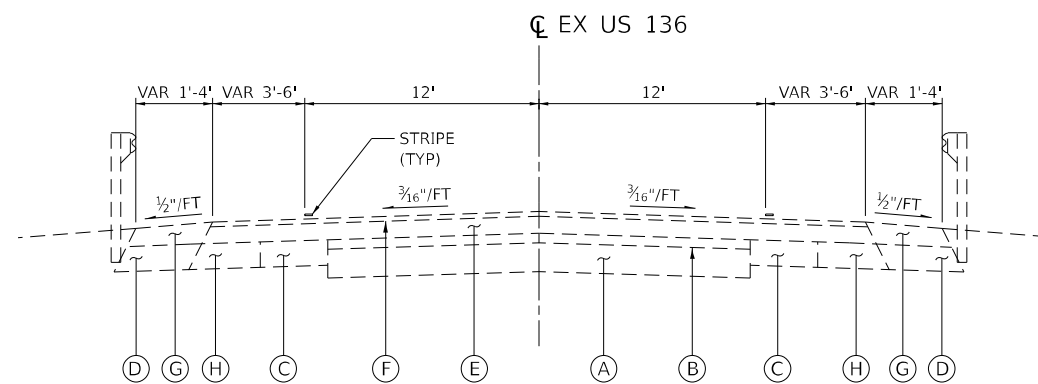

**EXISTING TYPICAL SECTION**

STA 322+58 TO STA 323+58  
 STA 326+62 TO STA 327+62

MODEL: EX TYPICALS - 1 (Sheet)  
 FILE NAME: S:\2023\2023\008\PTB 2025-30 DA - Hurst Roache - Various PH1 & IJWC2 Bridge Repair Plans 68H20CAD\CADD\_Sheet\0468H20-CH-Typical.dgn



USER NAME = rgoertz	DESIGNED - RG	REVISED -
DRAWN - TO	CHECKED - SMK	REVISED -
PLOT SCALE = 0.16666833' / in.	DATE -	REVISED -
PLOT DATE = 12/15/2023		

**STATE OF ILLINOIS  
 DEPARTMENT OF TRANSPORTATION**

**EXISTING TYPICAL SECTIONS  
 US 136**

SCALE: NONE SHEET 1 OF 2 SHEETS STA. TO STA.

F.A.P. RTE.	SECTION	COUNTY	TOTAL SHEETS	SHEET NO.
315/30	[139,138(BC;BC-1)BR, BR-1]BRR	FULTON	119	11
CONTRACT NO. 68H20				
ILLINOIS FED. AID PROJECT				

MODEL: EX TYPICAL S - 2 (Sheet)  
 FILE NAME: S:\2023\231106 PTB 206-30 D4 - Hurst Rosche - Various PH I & II\WO-2 Bridge Repair Plans 68H20\CADD\CADD Sheets\68H20-shr-typicals.dgn

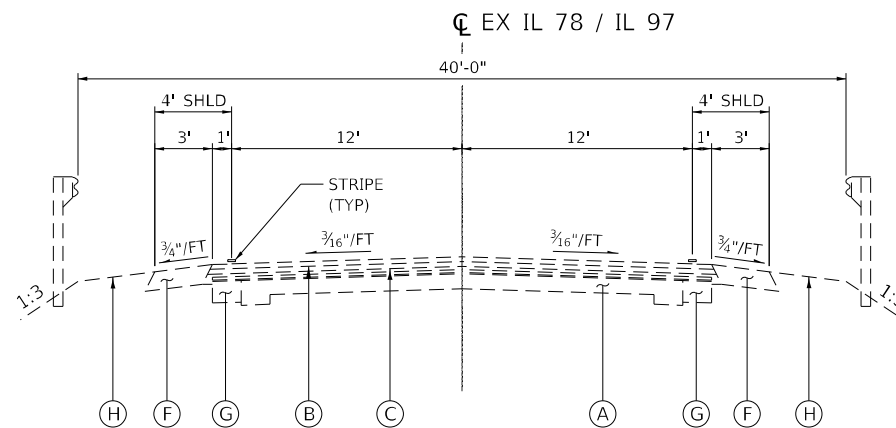

**EXISTING TYPICAL SECTION**

STA 489+45 ± TO STA 490+15 ±  
 STA 495+85 ± TO STA 497+00 ±  
 STA 503+00 ± TO STA 503+60 ±  
 STA 513+40 ± TO STA 514+00 ±  
 STA 534+00 ± TO STA 534+79 ±  
 STA 536+86 ± TO STA 537+66 ±

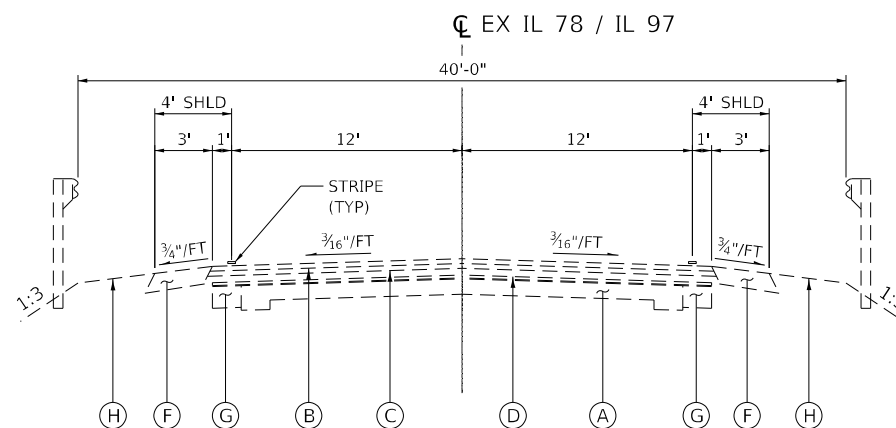

**EXISTING TYPICAL SECTION**

STA 490+15 ± TO STA 490+84 ±  
 STA 495+15 ± TO STA 495+85 ±  
 STA 503+60 ± TO STA 504+95 ±  
 STA 512+75 ± TO STA 514+00 ±

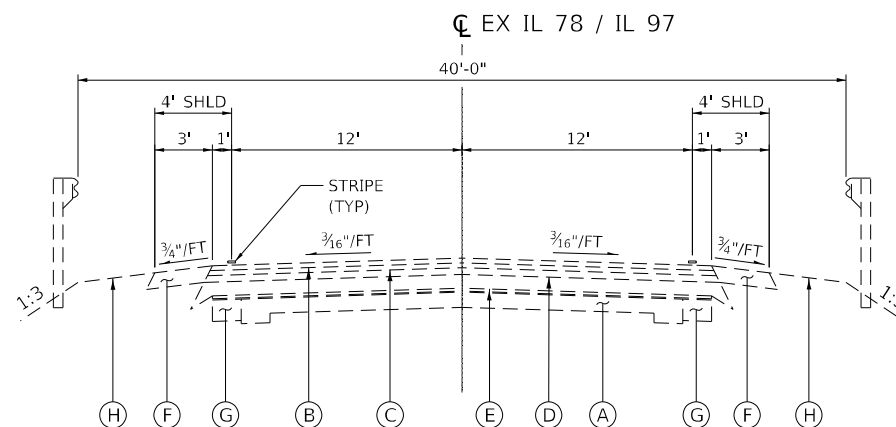

**EXISTING TYPICAL SECTION**

STA 511+27 ± TO STA 512+67 ±

**LEGEND**

- (A) EX 9" PCC PAVEMENT WITH OVERLAY
- (B) EX HMA SURFACE COURSE, 1 1/2"
- (C) EX HMA BINDER, 1 1/2"
- (D) EX HMA BASE, VAR 3"-8"
- (E) EX GRANULAR EMBENKMENT (SP), VAR 6"-24"
- (F) EX AGGREGATE SHOULDERS
- (G) EX WIDENING
- (H) EX EMBANKMENT



USER NAME = rgoertz	DESIGNED -	REVISED -
PLOT SCALE = 0.16666833' / in.	DRAWN -	REVISED -
PLOT DATE = 12/14/2023	CHECKED -	REVISED -
	DATE -	REVISED -

**STATE OF ILLINOIS  
DEPARTMENT OF TRANSPORTATION**

**EXISTING TYPICAL SECTIONS  
IL 78 / IL 97**

SCALE: NONE SHEET 2 OF 2 SHEETS STA. TO STA.

F.A.P. RTE.	SECTION	COUNTY	TOTAL SHEETS	SHEET NO.
315/30	1139,138(BC;BC-1)BR,BR-1)BRR	FULTON	119	12
CONTRACT NO. 68H20				
ILLINOIS FED. AID PROJECT				

MODEL: PR TYPICALS - 1 (Sheet)  
 FILE NAME: S:\2023\231006 PTB 206-30 D4 - Hurst Rosche - Various PH I & II\WO-2 Bridge Repair Plans 68H20\CADD\CADD Sheets\68H20-shr-typicals.dgn

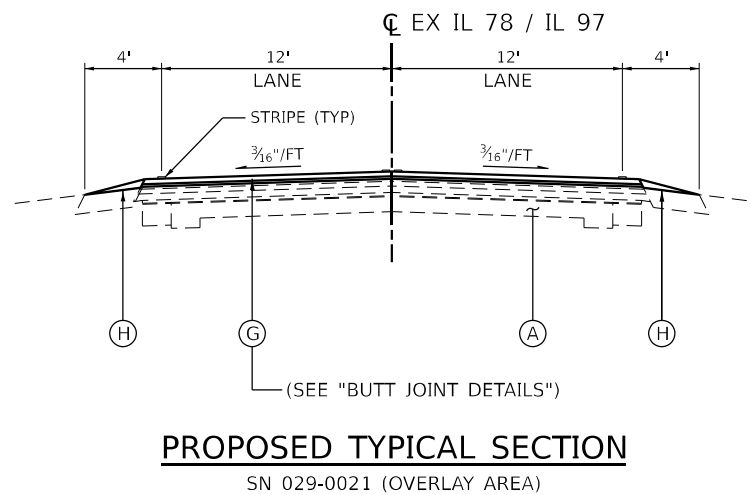
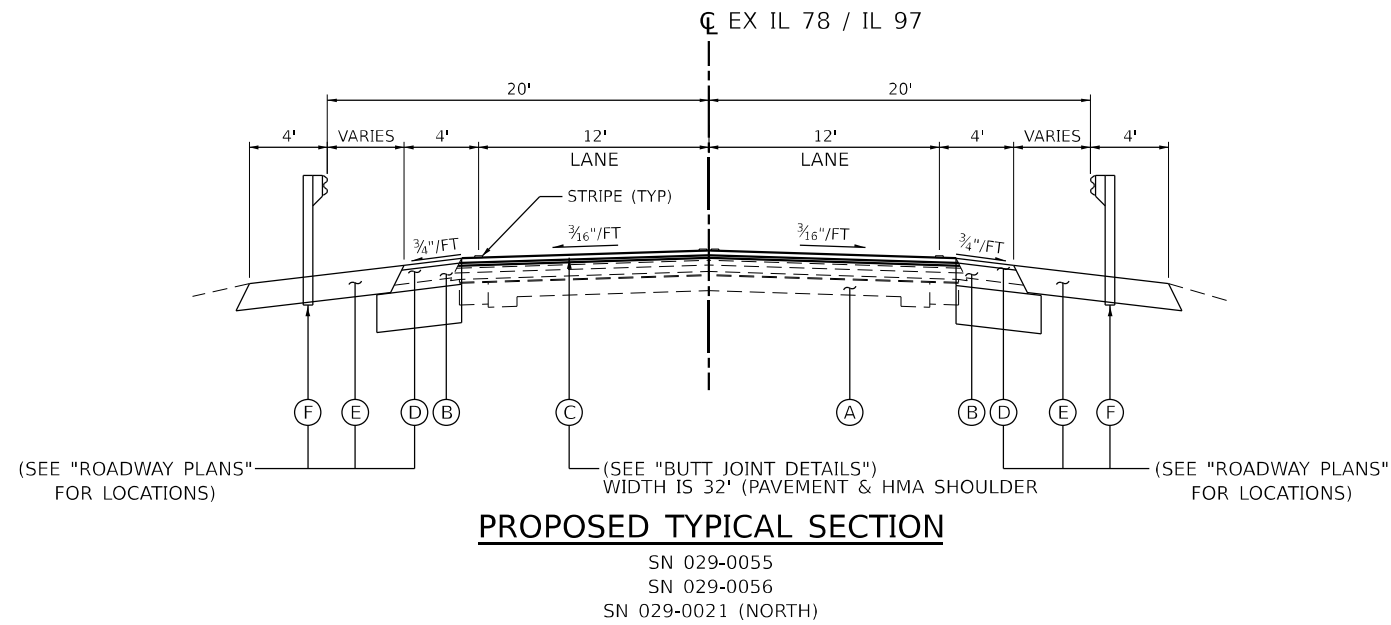
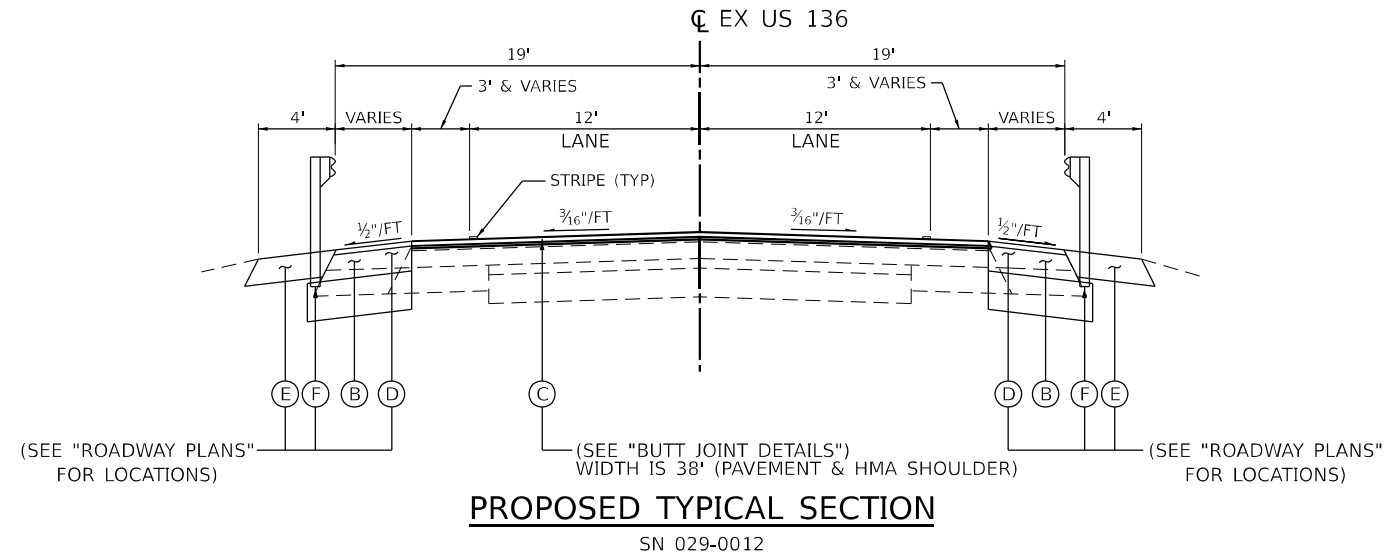

**LEGEND**

- (A) EX PAVEMENT
- (B) EX AGGREGATE SHOULDERS
- (C) POLYMERIZED HOT-MIX ASPHALT SURFACE COURSE, IL-9.5, MIX "D", N70 (1 1/2")  
HOT-MIX ASPHALT SURFACE REMOVAL - BUTT JOINT  
POLYMERIZED BITUMINOUS MATERIALS (TACK COAT)
- (D) EXCAVATING AND GRADING EXISTING SHOULDER  
HOT-MIX ASPHALT SHOULDERS, 8"  
AGGREGATE SUBGRADE IMPROVEMENT 12"
- (E) GUARDRAIL AGGREGATE EROSION CONTROL
- (F) STEEL PLATE BEAM GUARDRAIL, TYPE A, 6 FOOT POSTS
- (G) POLYMERIZED HOT-MIX ASPHALT SURFACE COURSE, IL-9.5, MIX "D", N70 (1 1/2")  
POLYMERIZED HOT-MIX ASPHALT BINDER COURSE, IL-9.5, N70 (1")  
HOT-MIX ASPHALT SURFACE REMOVAL, 1"  
POLYMERIZED BITUMINOUS MATERIALS (TACK COAT)
- (H) AGGREGATE WEDGE SHOULDER, TYPE B

**NOTE:**

1. SEE DISTRICT 4 STANDARD DRAWING - "GUARDRAIL EROSION CONTROL TREATMENTS"



USER NAME = rgoertz	DESIGNED - RG	REVISED -
PLOT SCALE = 0.16666833' / in.	DRAWN - TO	REVISED -
PLOT DATE = 12/14/2023	CHECKED - SMK	REVISED -
	DATE -	REVISED -

STATE OF ILLINOIS  
 DEPARTMENT OF TRANSPORTATION

PROPOSED TYPICAL SECTIONS  
 US 136 / IL 78 / IL 97

SCALE: NONE SHEET 1 OF 1 SHEETS STA. TO STA.

F.A.P. RTE.	SECTION	COUNTY	TOTAL SHEETS	SHEET NO.
315/30	1139,138(BC,BC-1)BR,BR-1BRR	FULTON	119	13
CONTRACT NO. 68H20				
ILLINOIS FED. AID PROJECT				

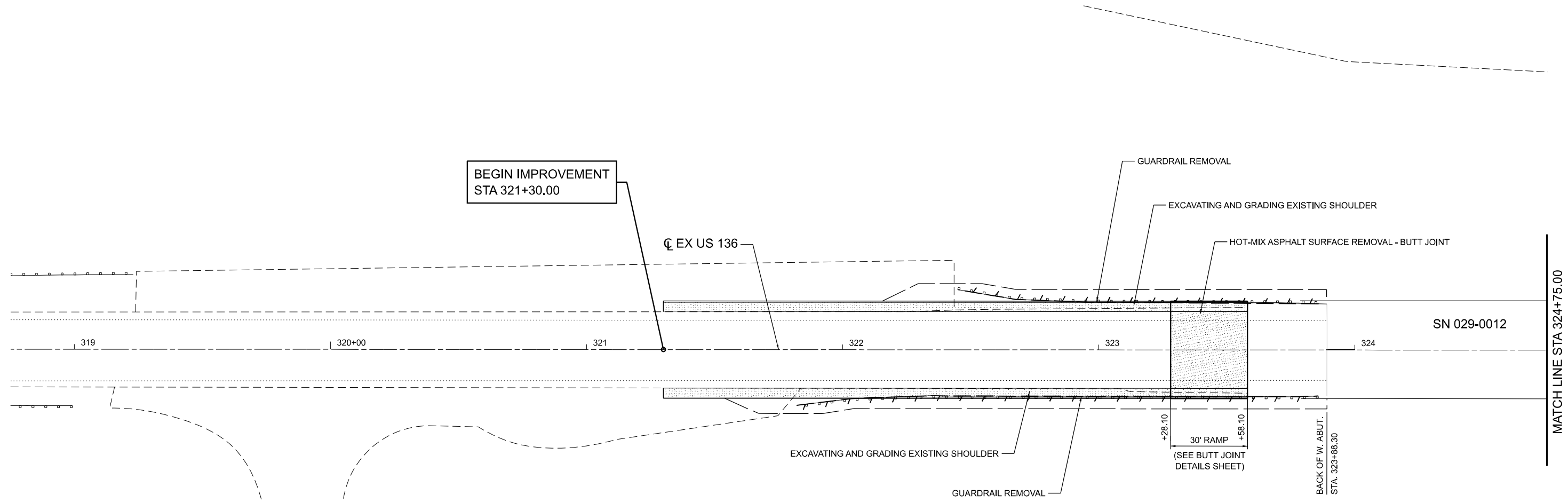
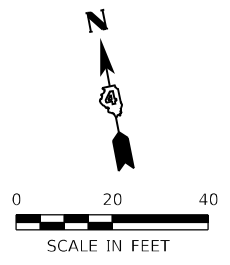

MODEL: Unnamed Plan - Plan 11 (Sheet)  
 FILE NAME: S:\2023\231006 PTB\_206-30\_D4 - Hurst Rosche - Various PH1 & IIWO-2 Bridge Repair Plans 68H20\CADD\CADD Sheets\68H20-shrtem.dgn



USER NAME = rgoertz	DESIGNED - RG	REVISED -
DRAWN - TO	REVISOR -	
PLOT SCALE = 0.16666833' / in.	CHECKED - SMK	REVISED -
PLOT DATE = 12/14/2023	DATE -	REVISED -

**STATE OF ILLINOIS**  
**DEPARTMENT OF TRANSPORTATION**

<b>REMOVAL PLANS</b> <b>US 136 (SN 029-0012)</b>			
SCALE: 1" = 20'	SHEET 1	OF 9 SHEETS	TO STA. 324+75.00

F.A.P. RTE.	SECTION	COUNTY	TOTAL SHEETS	SHEET NO.
315/30	1139,138(BC;BC-1)BR, BR-1(BRR)	FULTON	119	14
CONTRACT NO. 68H20				
ILLINOIS FED. AID PROJECT				

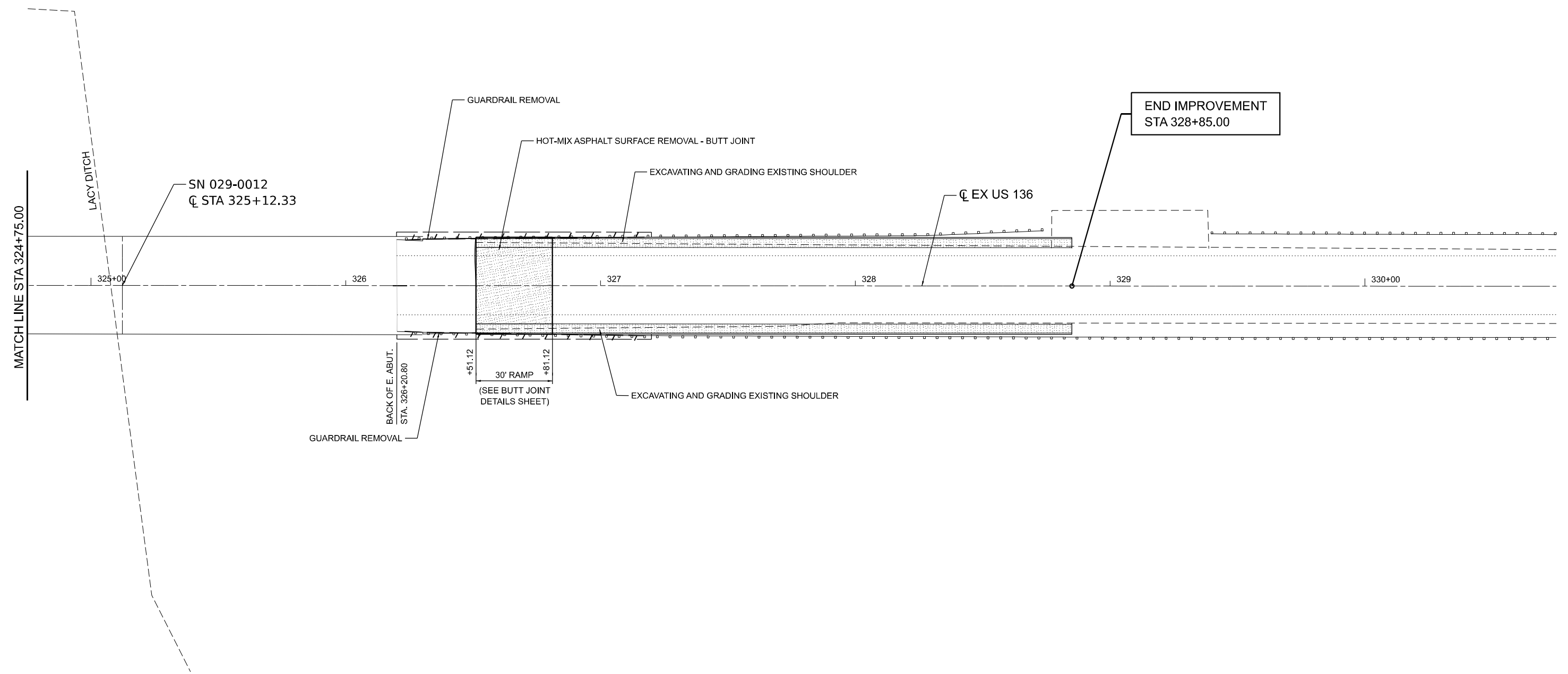
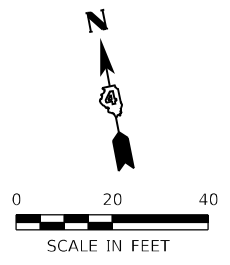

MODEL: Unnamed Plan - Plan 12 (Sheet)  
 FILE NAME: S:\2023\231006 PTB\206-30 D4 - Hurst Rosche - Various PH I & II\WO-2 Bridge Repair Plans 68H20\CADD\CADD Sheets\68H20-shrcrem.dgn



USER NAME = rgoertz	DESIGNED - RG	REVISED -
PLOT SCALE = 0.16666633' / in.	DRAWN - TO	REVISED -
PLOT DATE = 12/14/2023	CHECKED - SMK	REVISED -
	DATE -	REVISED -

**STATE OF ILLINOIS**  
**DEPARTMENT OF TRANSPORTATION**

**REMOVAL PLANS**  
**US 136 (SN (029-0012))**

SCALE: 1" = 20'    SHEET 2    OF 9    SHEETS    STA. 324+75.00    TO STA. 328+85.00

F.A.P. RTE.	SECTION	COUNTY	TOTAL SHEETS	SHEET NO.
315/30	1139,138(BC,BC-1)BR,BR-1)BRR	FULTON	119	15
CONTRACT NO. 68H20				
ILLINOIS FED. AID PROJECT				

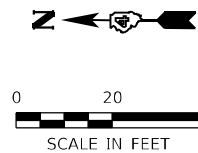

BEGIN IMPROVEMENT  
STA 488+45.00

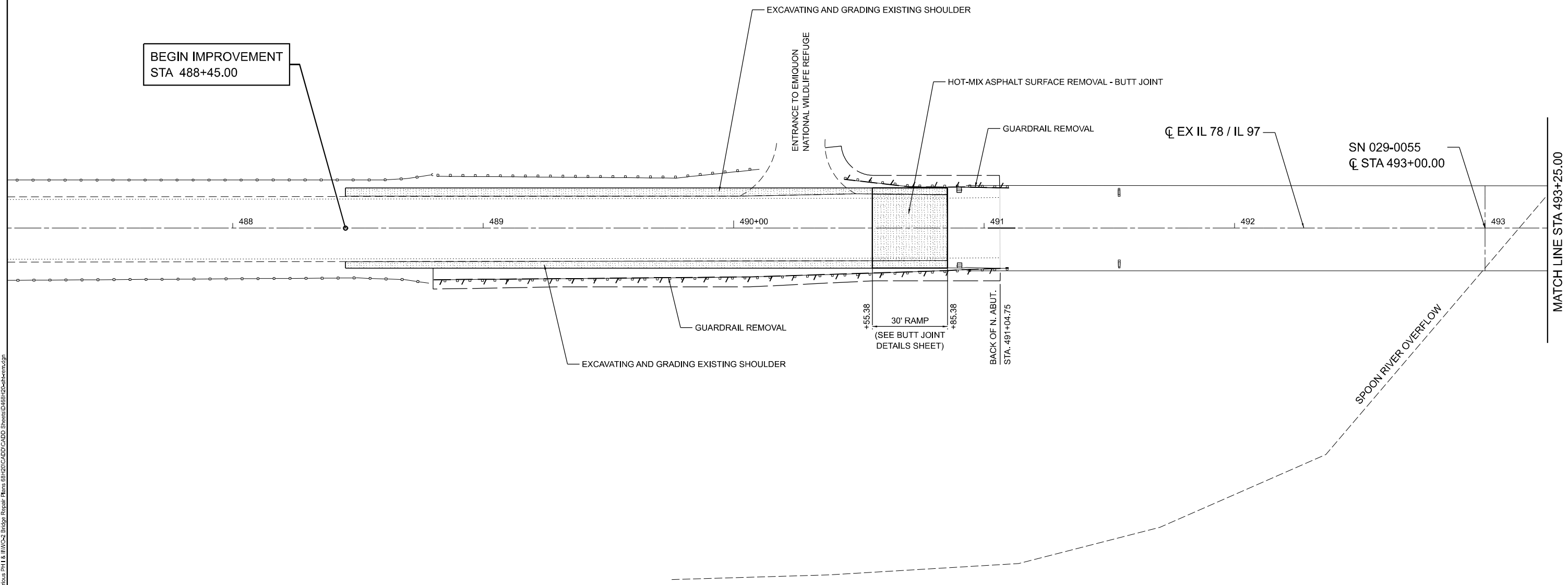

MODEL: Unnamed (Plan) - File: E:\Sheet4  
 FILE NAME: S:\2023\2311\08\PTB 2023\04 - Hurst Roache - Various PH1 & IIVC2 Bridge Repair Plans 68H20\CAD\CADD\_Sheet4\488+45.00-493+25.00.dwg



USER NAME = rgoertz	DESIGNED - RG	REVISED -
DRAWN - TO	REVISOR -	
PLOT SCALE = 0.16666633' / in.	CHECKED - SMK	REVISED -
PLOT DATE = 12/15/2023	DATE -	REVISED -

**STATE OF ILLINOIS  
DEPARTMENT OF TRANSPORTATION**

<b>REMOVAL PLANS</b>			
<b>IL 78 / IL 97 (SN 029-0055)</b>			
SCALE: 1" = 20'	SHEET 3	OF 9 SHEETS	STA. 488+45.00 TO STA. 493+25.00

F.A.P. RTE.	SECTION	COUNTY	TOTAL SHEETS	SHEET NO.
315/30	1139,138(BC;BC-1)BR,BR-1 BRR	FULTON	119	16
CONTRACT NO. 68H20				
ILLINOIS FED. AID PROJECT				



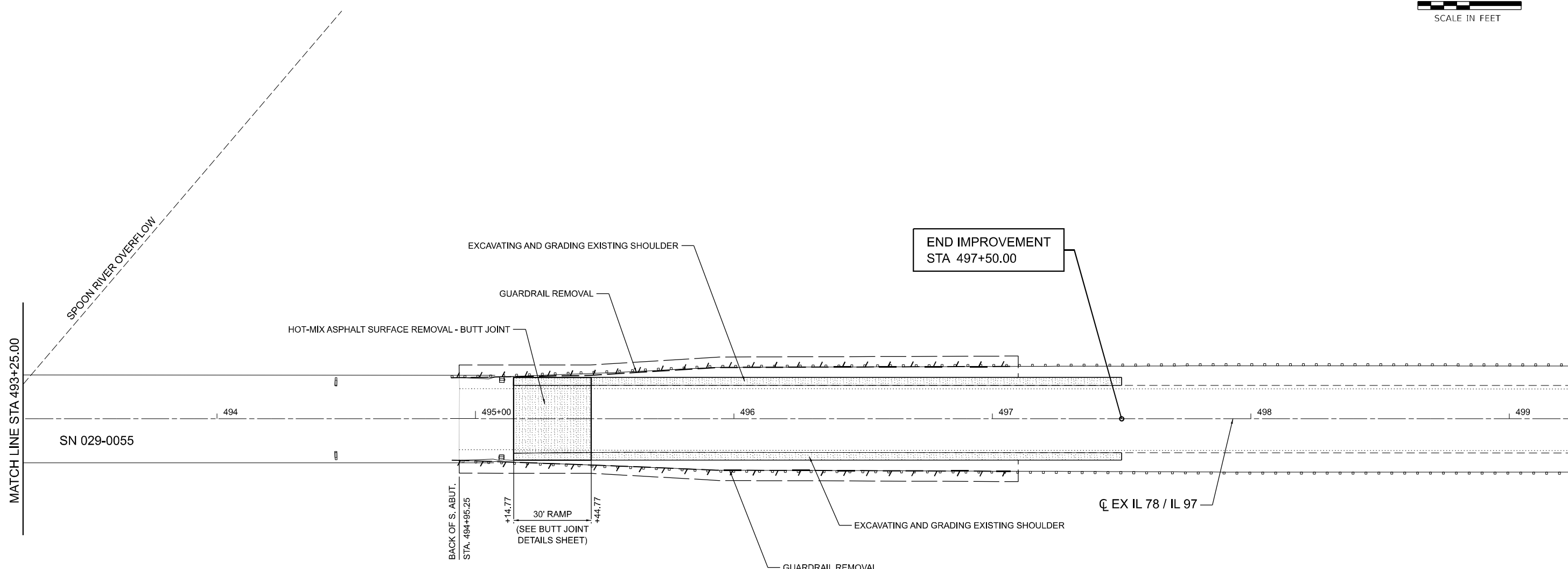
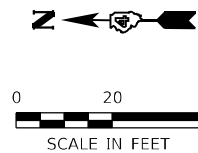

MODEL: Unnamed (Plan - Sheet 4) (Sheet)  
 FILE NAME: S:\2023\231106\PTB 2023\04 - Hurst Roache - Various PH1 & IJWC2 Bridge Repair Plans 68H20CADD\CADD\_Sheet\0468H20-4-Plan.dwg



USER NAME = rgoertz	DESIGNED - RG	REVISED -
DRAWN - TO	CHECKED - SMK	REVISED -
PLOT SCALE = 0.166666833' / in.	DATE -	REVISED -
PLOT DATE = 12/15/2023		

**STATE OF ILLINOIS**  
**DEPARTMENT OF TRANSPORTATION**

<b>REMOVAL PLANS</b> <b>IL 78 / IL 97 (SN 029-0055)</b>			
SCALE: 1" = 20'	SHEET 4	OF 9 SHEETS	STA. 493+25.00 TO STA. 497+50.00

F.A.P. RTE.	SECTION	COUNTY	TOTAL SHEETS	SHEET NO.
315/30	1139,138(BC;BC-1)BR,BR-1 BRR	FULTON	119	17
CONTRACT NO. 68H20				
ILLINOIS FED. AID PROJECT				

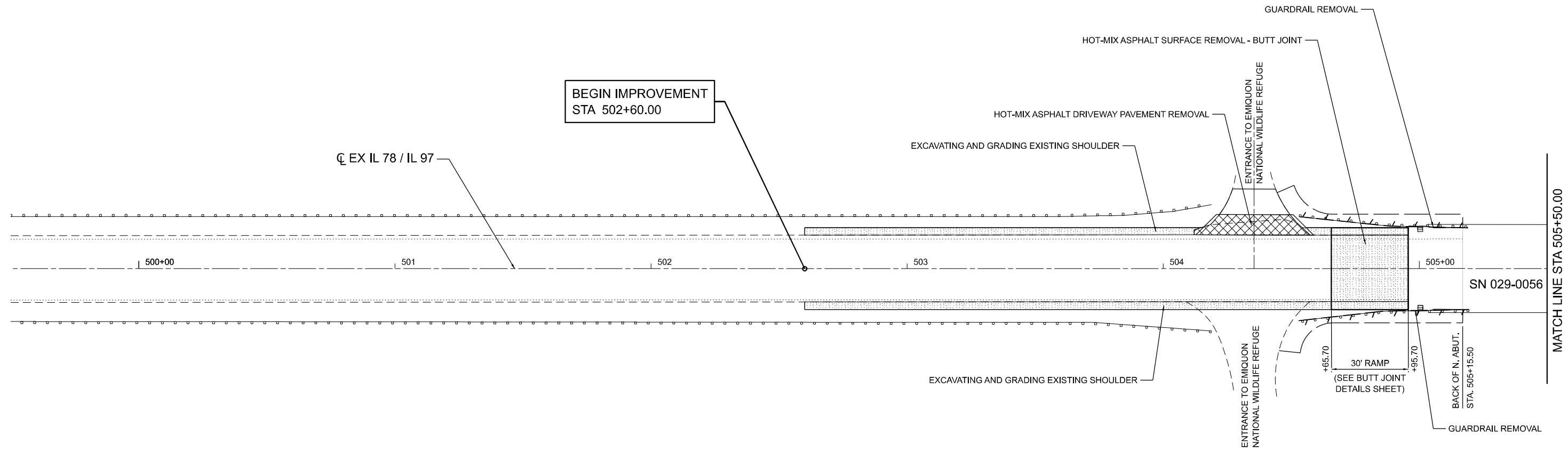
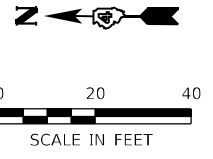

MODEL: Unnamed (Plan - File 3) (Sheet)  
 FILE NAME: S:\2023\21\LOG PTB 202301.DWG - Hurst Roache - Various PH1 & IIVC2 Bridge Repair Plans 68H20CAD00.CADD\_Sheet0468H20-468.dwg



USER NAME = rgoertz	DESIGNED - RG	REVISED -
	DRAWN - TO	REVISED -
PLOT SCALE = 0.16666633' / in.	CHECKED - SMK	REVISED -
PLOT DATE = 12/15/2023	DATE -	REVISED -

**STATE OF ILLINOIS**  
**DEPARTMENT OF TRANSPORTATION**

<b>REMOVAL PLANS</b> <b>IL 78 / 97 (SN 029-0056)</b>			
SCALE: 1" = 20'	SHEET 5	OF 9 SHEETS	STA. 502+60.00 TO STA. 505+50.00

F.A.P. RTE.	SECTION	COUNTY	TOTAL SHEETS	SHEET NO.
315/30	[139,138(BC;BC-1)BR, BR-1]BRR	FULTON	119	18
CONTRACT NO. 68H20				
ILLINOIS FED. AID PROJECT				

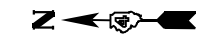

MATCH LINE STA 505+50.00

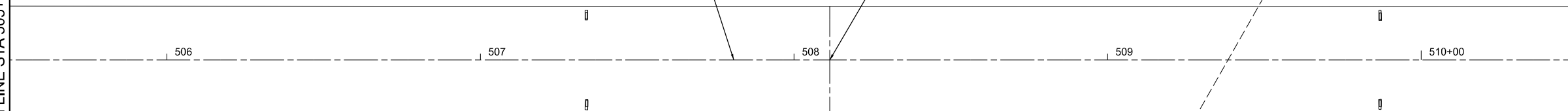

MATCH LINE STA 510+50.00

MODEL: Unnamed (1) - File 0 (Sheet)  
FILE NAME: S:\2023\21006\21006\_P18\_202301.DWG - Hurst Roache - Various PH1 & IJWC2 Bridge Repair Plans 68H20CAD\CADD\_Sheet\21006\_P18\_202301.dwg



USER NAME =	rgoertz
PLOT SCALE =	0.16666633' / in.
PLOT DATE =	12/15/2023

DESIGNED -	RG
DRAWN -	TO
CHECKED -	SMK
DATE -	

REVISED -	
REVISED -	
REVISED -	
REVISED -	

**STATE OF ILLINOIS  
DEPARTMENT OF TRANSPORTATION**

<b>REMOVAL PLANS</b>			
<b>IL 78 / IL 97 (SN 029-0056)</b>			
SCALE: 1" = 20'	SHEET 6	OF 9 SHEETS	STA. 505+50.00 TO STA. 510+50.00

F.A.P. RTE.	SECTION	COUNTY	TOTAL SHEETS	SHEET NO.
315/30	1139,138(BC;BC-1)BR,BR-1(BRR)	FULTON	119	19
CONTRACT NO. 68H20				
ILLINOIS FED. AID PROJECT				

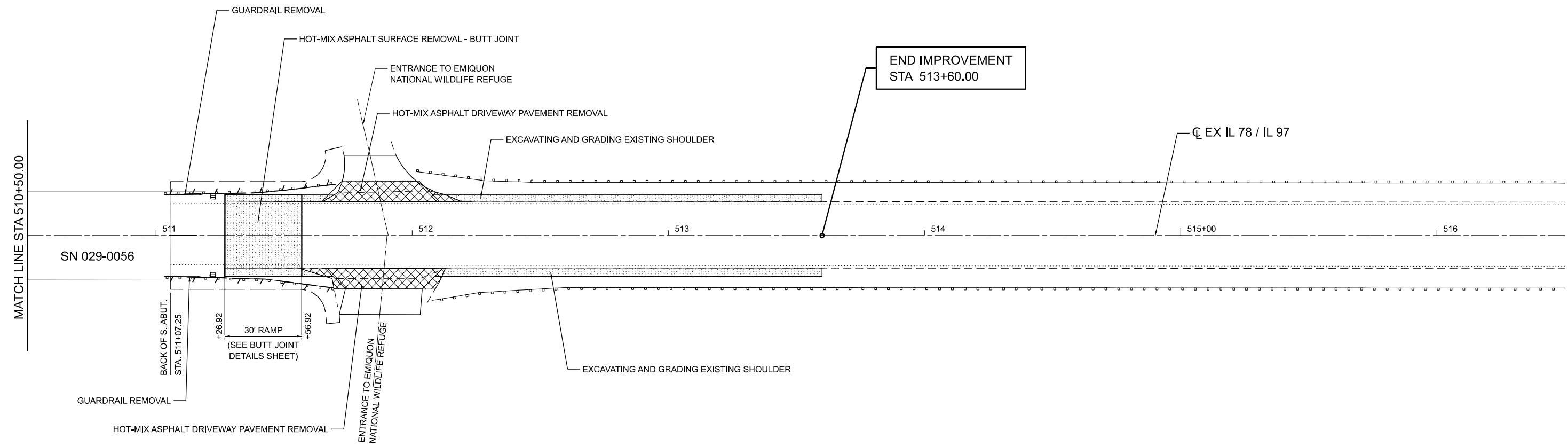
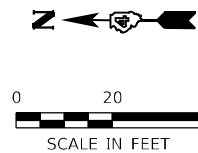

MODEL: Unnamed (Plan - 0) - Sheet 1 (Sheet 1)  
 FILE NAME: S:\2023\2311\08\PTB 2023-04 - Hurst Roache - Various PH1 & IIVC2 Bridge Repair Plans 68H20CAD00\ADD\_Sheet0468H20-14-ken.dgn



USER NAME = rgoertz	DESIGNED - RG	REVISED -
	DRAWN - TO	REVISED -
PLOT SCALE = 0.16666633' / in.	CHECKED - SMK	REVISED -
PLOT DATE = 12/15/2023	DATE -	REVISED -

**STATE OF ILLINOIS**  
**DEPARTMENT OF TRANSPORTATION**

<b>REMOVAL PLANS</b> <b>IL 78 / IL 97 (SN 029-0056)</b>			
SCALE: 1" = 20'	SHEET 7	OF 9 SHEETS	STA. 510+50.00 TO STA. 513+60.00

F.A.P. RTE.	SECTION	COUNTY	TOTAL SHEETS	SHEET NO.
315/30	1139,138(BC;BC-1)BR,BR-1)BRR	FULTON	119	20
CONTRACT NO. 68H20				
ILLINOIS FED. AID PROJECT				

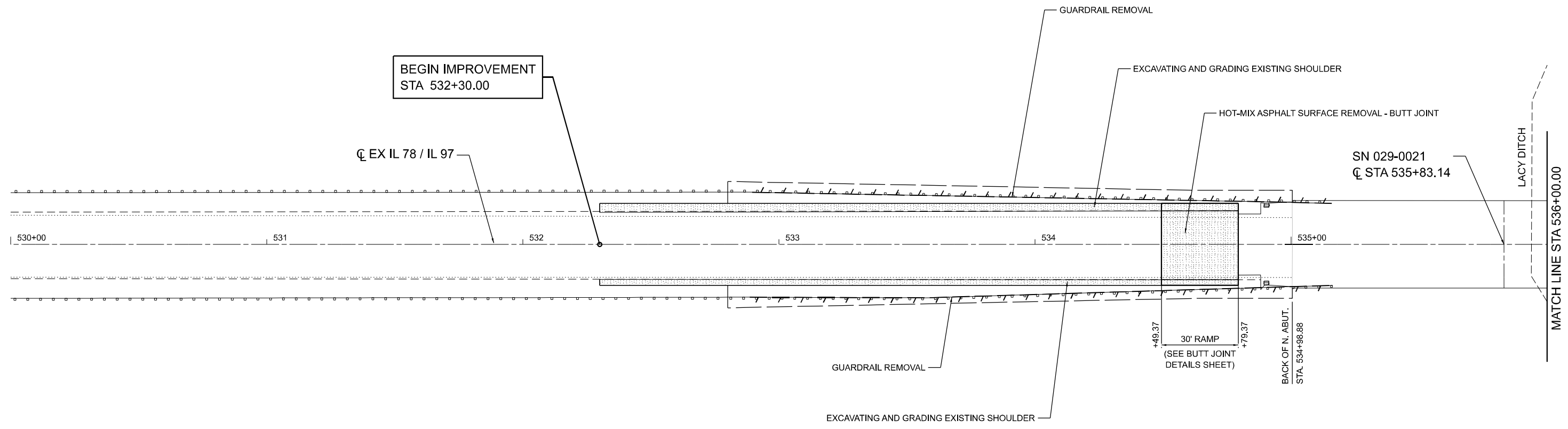
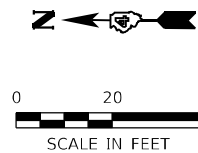

MODEL: Unnamed Plan - Plan 6 (Sheet)  
 FILE NAME: S:\2023\2311\06 PTB 206-30 D4 - Hurst Rosche - Various PH1 & IIWO-2 Bridge Repair Plans 68H20\CADD\CADD Sheets\68H20-shrtem.dgn



USER NAME = rgoertz	DESIGNED - RG	REVISED -
DRAWN - TO	DRAWN - TO	REVISED -
PLOT SCALE = 0.16666633' / in.	CHECKED - SMK	REVISED -
PLOT DATE = 12/14/2023	DATE -	REVISED -

**STATE OF ILLINOIS**  
**DEPARTMENT OF TRANSPORTATION**

<b>REMOVAL PLANS</b>			
<b>IL 78 / IL 97 (SN 029-0021)</b>			
SCALE: 1" = 20'	SHEET 8	OF 9 SHEETS	STA. 532+30.00 TO STA. 536+00.00

F.A.P. RTE.	SECTION	COUNTY	TOTAL SHEETS	SHEET NO.
315/30	1139,138(BC;BC-1)BR,BR-1)BRR	FULTON	119	21
CONTRACT NO. 68H20			ILLINOIS FED. AID PROJECT	

MODEL: Unnamed Plan - Plan 7 (Sheet)  
 FILE NAME: S:\2023\23IL06 PTB 206-30 D4 - Hurst Rosche - Various PH1 & IIWO-2 Bridge Repair Plans 68H20\CADD\CADD Sheets\468H20-shr-em.dgn

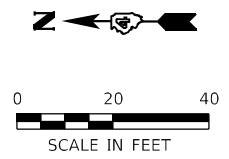
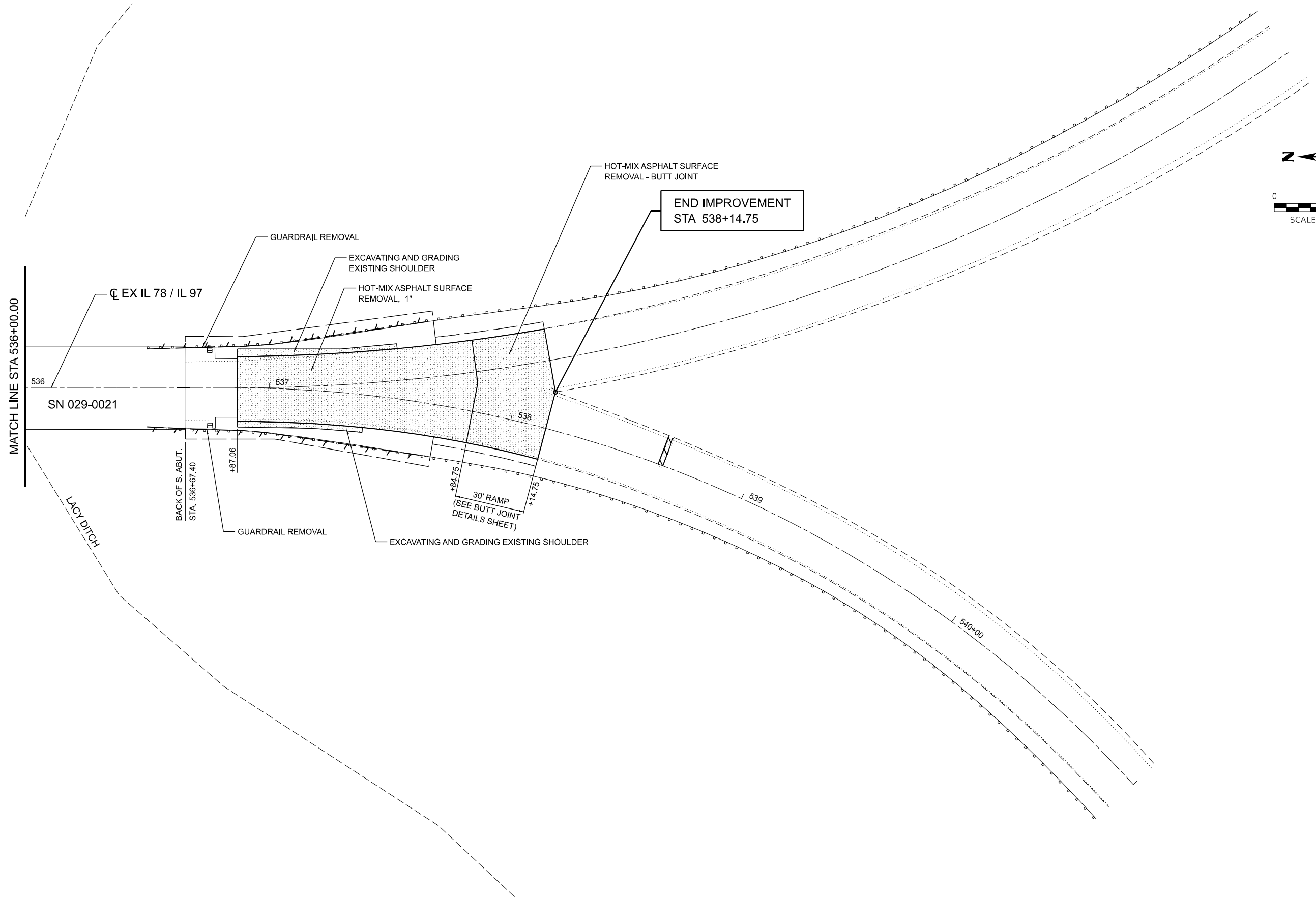

USER NAME = rgoertz	DESIGNED - RG	REVISED -
	DRAWN - TO	REVISED -
PLOT SCALE = 0.16666633' / in.	CHECKED - SMK	REVISED -
PLOT DATE = 12/14/2023	DATE -	REVISED -

**STATE OF ILLINOIS  
 DEPARTMENT OF TRANSPORTATION**

<b>REMOVAL PLANS</b>			
<b>IL 78 / IL 97 (SN 029-0021)</b>			
SCALE: 1" = 20'	SHEET 9	OF 9 SHEETS	STA. 536+00.00 TO STA. 537+50.00

F.A.P. RTE.	SECTION	COUNTY	TOTAL SHEETS	SHEET NO.
315/30	1139,138(BC,BC-1)BR,BR-1BRR	FULTON	119	22
CONTRACT NO. 68H20				
ILLINOIS FED. AID PROJECT				

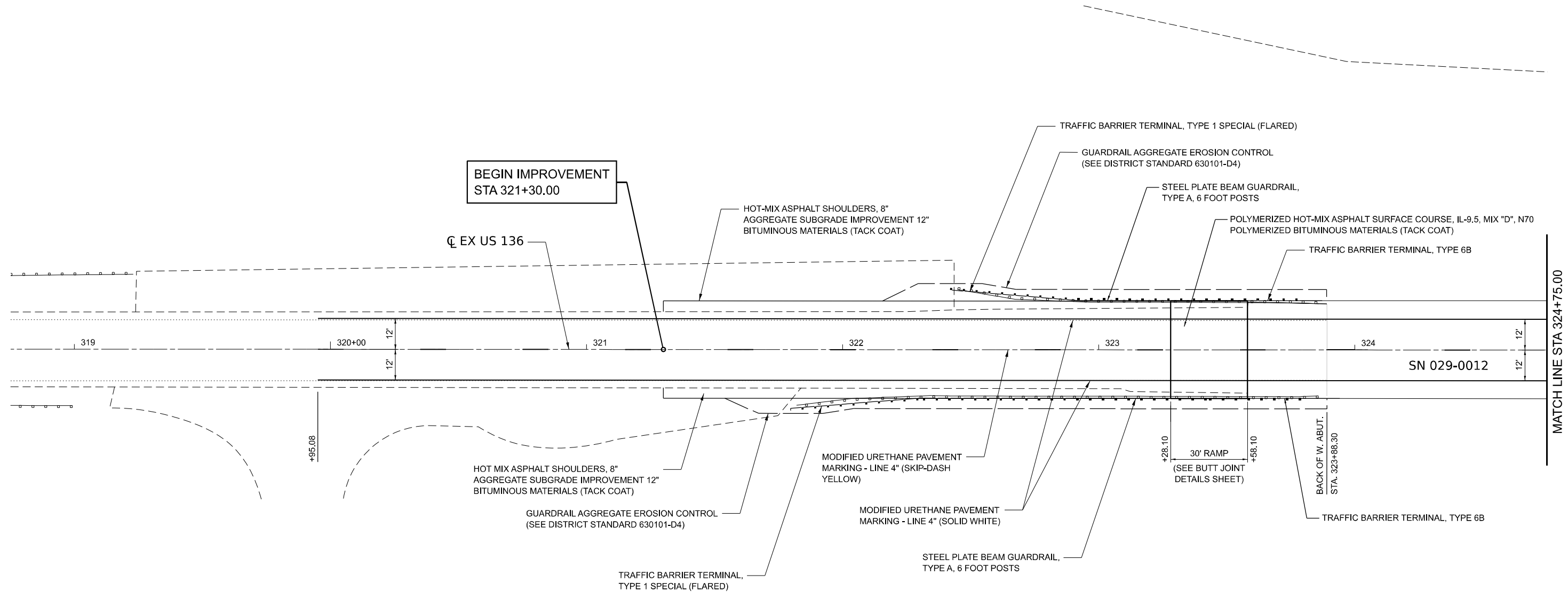
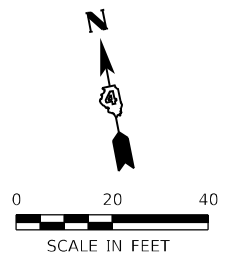

MODEL: Unnamed Plan - Plan 11 (Sheet)  
 FILE NAME: S:\2023\2311\06 PTB\_206-30\_D4 - Hurst Rosche - Various PH I & II\WO-2 Bridge Repair Plans 68H20\CADD\CADD Sheets\468H20-shp-plan.dgn



USER NAME = rgoertz	DESIGNED - RG	REVISED -
DRAWN - TO	REVISOR -	
PLOT SCALE = 0.16666633' / in.	CHECKED - SMK	REVISED -
PLOT DATE = 12/14/2023	DATE -	REVISED -

**STATE OF ILLINOIS**  
**DEPARTMENT OF TRANSPORTATION**

**ROADWAY PLANS**  
**US 136 (SN 029-0012)**

SCALE: 1" = 20'    SHEET 1    OF 9    SHEETS    STA. 321+30.00    TO STA. 324+75.00

F.A.P. RTE.	SECTION	COUNTY	TOTAL SHEETS	SHEET NO.
315/30	1139,138(BC;BC-1)BR,BR-1)BRR	FULTON	119	23
CONTRACT NO. 68H20				
ILLINOIS FED. AID PROJECT				

MATCH LINE STA 324+75.00

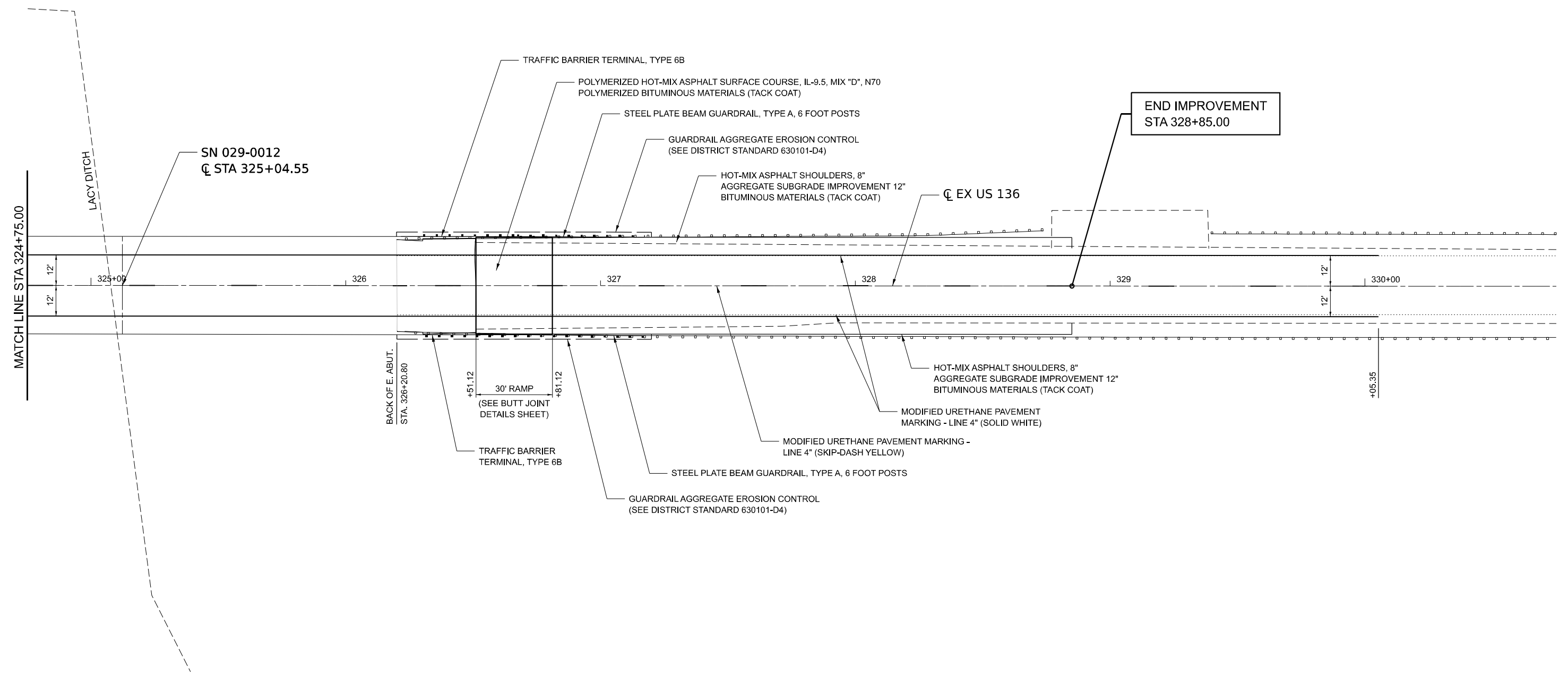
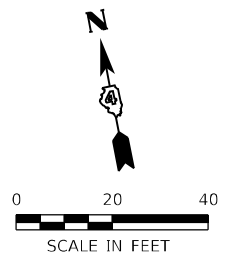

MODEL: Unnamed Plan - Plan 12 (Sheet)  
 FILE NAME: S:\2023\2311\06 PTB\206-30 D4 - Hurst Rosche - Various PH I & II\WO-2 Bridge Repair Plans 68H20\CADD\CADD Sheets\68H20-sht-plan.dgn



USER NAME = rgoertz	DESIGNED - RG	REVISED -
PLOT SCALE = 0.16666833' / in.	DRAWN - TO	REVISED -
PLOT DATE = 12/14/2023	CHECKED - SMK	REVISED -
	DATE -	REVISED -

**STATE OF ILLINOIS  
DEPARTMENT OF TRANSPORTATION**

**ROADWAY PLANS  
US 136 (SN 029-0012)**

SCALE: 1" = 20'      SHEET 2      OF 9      SHEETS      STA. 324+75.00      TO STA. 328+85.00

F.A.P. RTE.	SECTION	COUNTY	TOTAL SHEETS	SHEET NO.
315/30	1139,138(BC,BC-1)BR,BR-1)BRR	FULTON	119	24
CONTRACT NO. 68H20				
ILLINOIS FED. AID PROJECT				



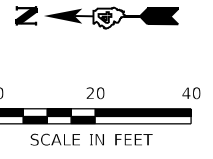

**BEGIN IMPROVEMENT  
STA 488+45.00**

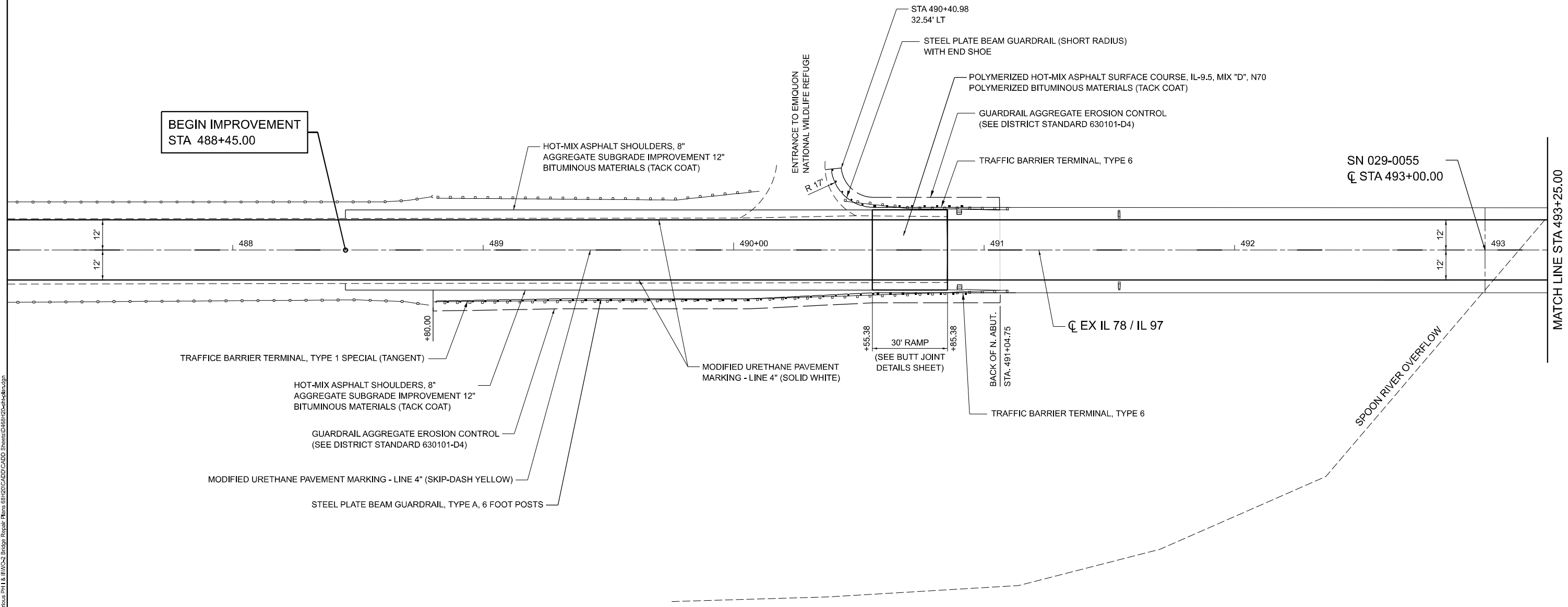

SN 029-0055  
CL STA 493+00.00

MATCH LINE STA 493+25.00

MODEL: Unnamed (Plan - File #) Sheet 3  
 FILE NAME: S:\2023\2311\08\PTB 2023-01-11\WCS\_Bridge\_Restore\_Plan\_88\2023\ADD\CADD\_Sheet\0488-20-24-Plan.dgn



USER NAME = rgoertz	DESIGNED - RG	REVISED -
PLOT SCALE = 0.16666633' / in.	DRAWN - TO	REVISED -
PLOT DATE = 12/15/2023	CHECKED - SMK	REVISED -
	DATE -	REVISED -

**STATE OF ILLINOIS  
DEPARTMENT OF TRANSPORTATION**

<b>ROADWAY PLANS</b>			
<b>IL 78 / IL 97 (SN 029-0055)</b>			
SCALE: 1" = 20'	SHEET 3	OF 9 SHEETS	STA. 488+45.00 TO STA. 493+25.00

F.A.P. RTE.	SECTION	COUNTY	TOTAL SHEETS	SHEET NO.
315/30	1139,138(BC;BC-1)BR,BR-1(BRR)	FULTON	119	25
CONTRACT NO. 68H20				
ILLINOIS FED. AID PROJECT				

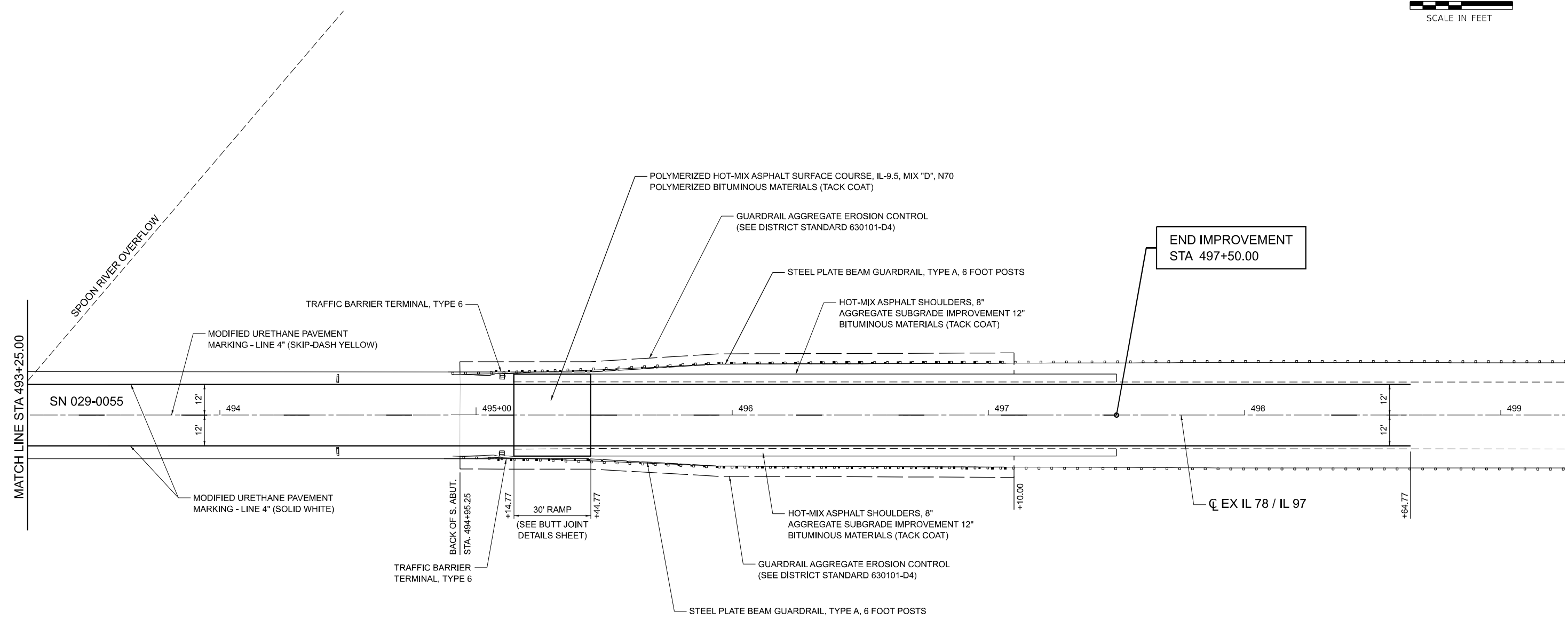
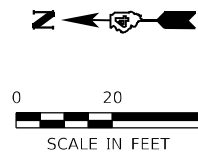

MODEL: Unnamed (Plan - Sheet 4) (Sheet)  
 FILE NAME: S:\2023\21\LOG PTB 2023-01.DWG - Hurst Roache - Various PH1 & IJWC2 Bridge Repair Plans 68H20\CADD\CADD\_Sheet\468H20-4-Plan.dwg



USER NAME = rgoertz	DESIGNED - RG	REVISED -
PLOT SCALE = 0.166666833' / in.	DRAWN - TO	REVISED -
PLOT DATE = 12/15/2023	CHECKED - SMK	REVISED -
	DATE -	REVISED -

**STATE OF ILLINOIS**  
**DEPARTMENT OF TRANSPORTATION**

<b>ROADWAY PLANS</b> <b>IL 78 / IL 97 (SN 029-0055)</b>			
SCALE: 1" = 20'	SHEET 4	OF 9 SHEETS	STA. 493+25.00 TO STA. 497+50.00

F.A.P. RTE.	SECTION	COUNTY	TOTAL SHEETS	SHEET NO.
315/30	[139,138](BC;BC-1)BR, BR-1 BRR	FULTON	119	26
CONTRACT NO. 68H20				
ILLINOIS FED. AID PROJECT				

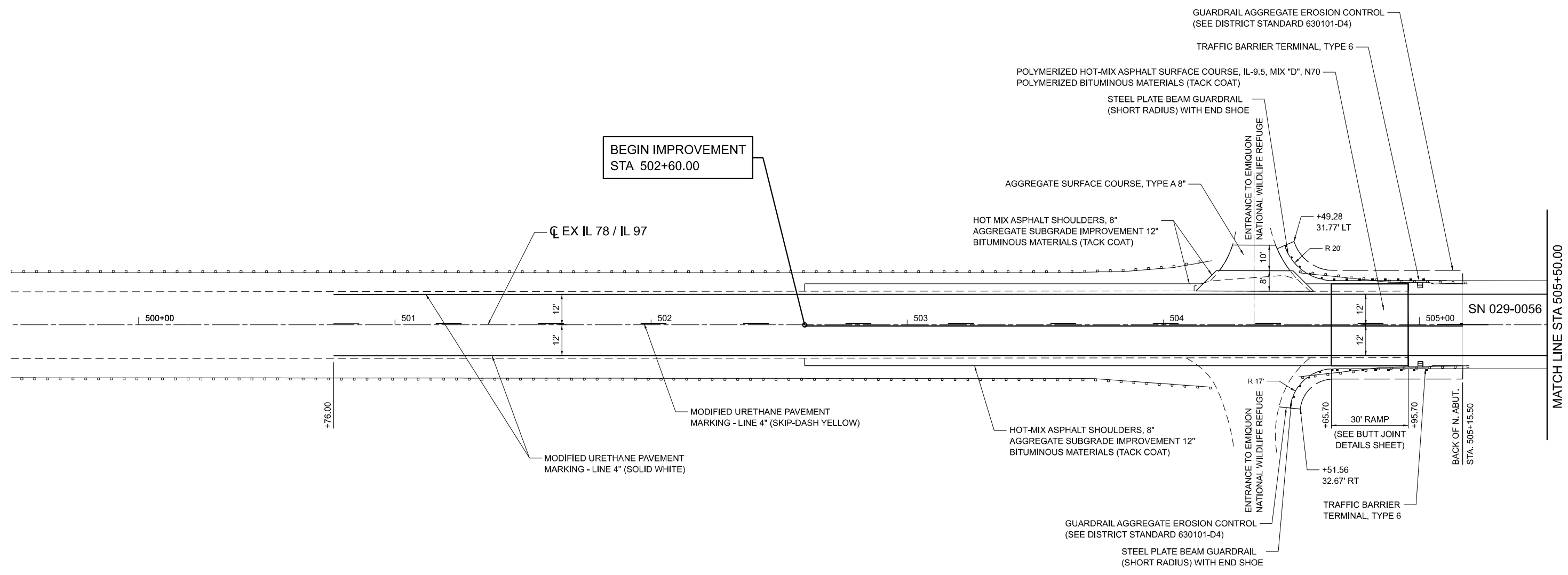
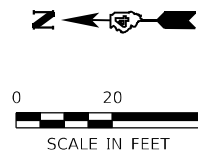

MODEL: Unnamed (Plan - File 3) (Sheet)  
 FILE NAME: S:\2023\21\LOG PTB 2023-01-11\WCS2\_Bridge\_Restore\_Plan\_68H20\CAD\CADD\_Sheet\0468H20-Plan.dgn



USER NAME = rgoertz	DESIGNED - RG	REVISED -
PLOT SCALE = 0.16666633' / in.	DRAWN - TO	REVISED -
PLOT DATE = 12/15/2023	CHECKED - SMK	REVISED -
	DATE -	REVISED -

**STATE OF ILLINOIS**  
**DEPARTMENT OF TRANSPORTATION**

<b>ROADWAY PLANS</b> <b>IL 78 / IL 97 (SN 029-0056)</b>			
SCALE: 1" = 20'	SHEET 5	OF 9 SHEETS	STA. 502+60.00 TO STA. 505+50.00

F.A.P. RTE.	SECTION	COUNTY	TOTAL SHEETS	SHEET NO.
315/30	[139,138](BC;BC-1)BR, BR-1(BRR)	FULTON	119	27
CONTRACT NO. 68H20				
ILLINOIS FED. AID PROJECT				

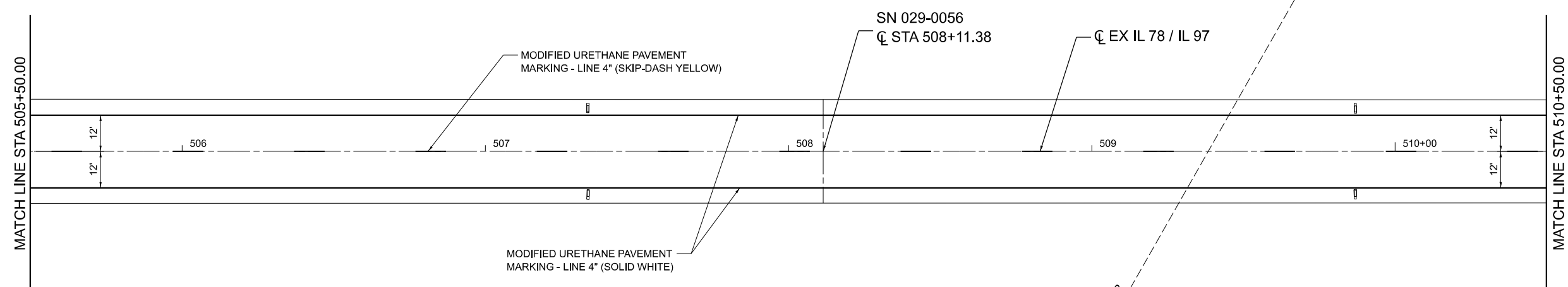
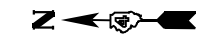

MODEL: Unnamed (Plan) - File 0 (Sheet)  
 FILE NAME: S:\2023\ILLINOIS\PTB 2023\04 - Hurst Roache - Various PH1 & ILLINOIS Bridge Repair Plans 68H20\CADD\CADD\_Sheet\0468H20-28.dgn



USER NAME = rgoertz	DESIGNED - RG	REVISED -
DRAWN - TO	REVISOR -	
PLOT SCALE = 0.16666633' / in.	CHECKED - SMK	REVISED -
PLOT DATE = 12/15/2023	DATE -	REVISED -

**STATE OF ILLINOIS**  
**DEPARTMENT OF TRANSPORTATION**

<b>ROADWAY PLANS</b> <b>IL 78 / IL 97 (SN 029-0056)</b>			
SCALE: 1" = 20'	SHEET 6	OF 9 SHEETS	STA. 505+50.00 TO STA. 510+50.00

F.A.P. RTE.	SECTION	COUNTY	TOTAL SHEETS	SHEET NO.
315/30	[139.138(BC,BC-1)BR,BR-1]BR	FULTON	119	28
CONTRACT NO. 68H20				
ILLINOIS FED. AID PROJECT				

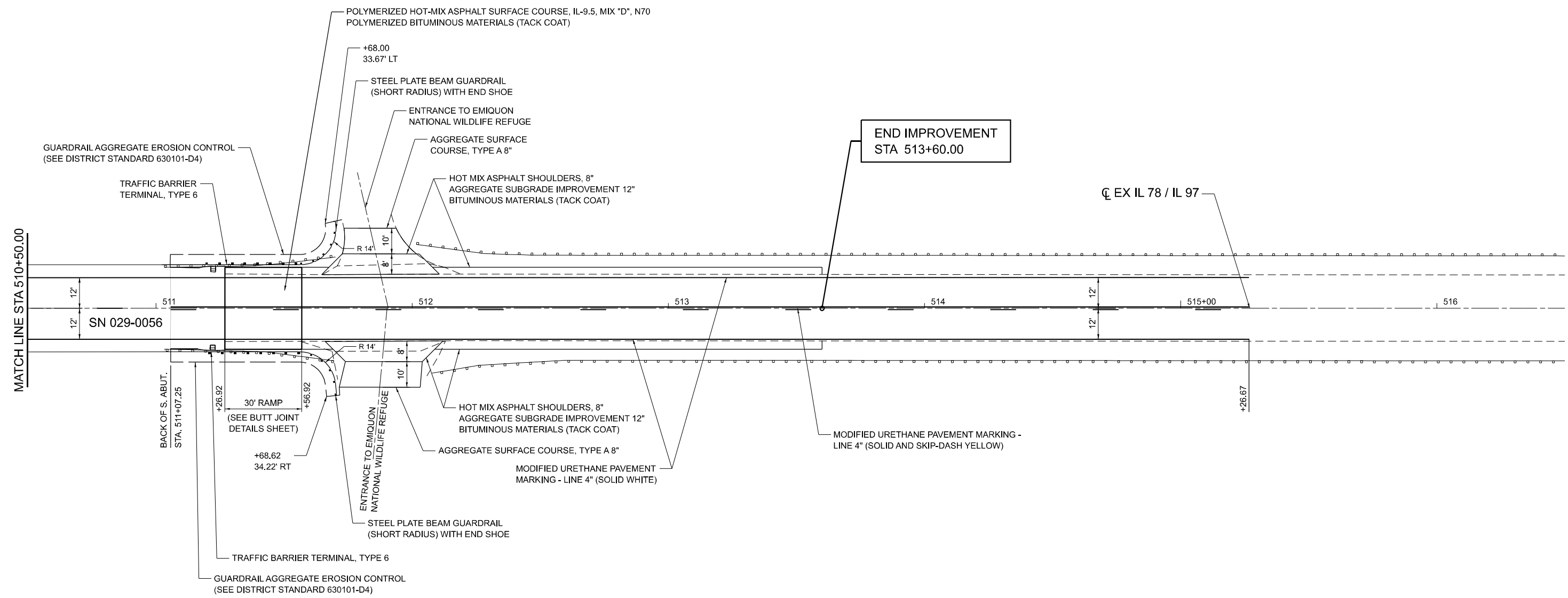
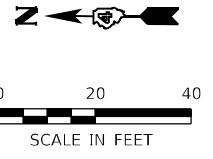

MODEL: Unnamed (Plan - 0) - 1 (Sheet)  
 FILE NAME: S:\2023\2311\08\PTB 2023-04 - Hurst Roache - Various PH1 & IJWC2 Bridge Repair Plans 68H20\CAD\CADD\_Sheet\0468H20-04.dgn



USER NAME = rgoertz	DESIGNED - RG	REVISED -
PLOT SCALE = 0.16666633' / in.	DRAWN - TO	REVISED -
PLOT DATE = 12/15/2023	CHECKED - SMK	REVISED -
	DATE -	REVISED -

**STATE OF ILLINOIS**  
**DEPARTMENT OF TRANSPORTATION**

<b>ROADWAY PLANS</b> <b>IL 78 / IL 97 (SN 029-0056)</b>			
SCALE: 1" = 20'	SHEET 7	OF 9 SHEETS	STA. 510+50.00 TO STA. 513+60.00

F.A.P. RTE.	SECTION	COUNTY	TOTAL SHEETS	SHEET NO.
315/30	[139,138(BC,BC-1)BR,BR-1]BRR	FULTON	119	29
CONTRACT NO. 68H20				
ILLINOIS FED. AID PROJECT				

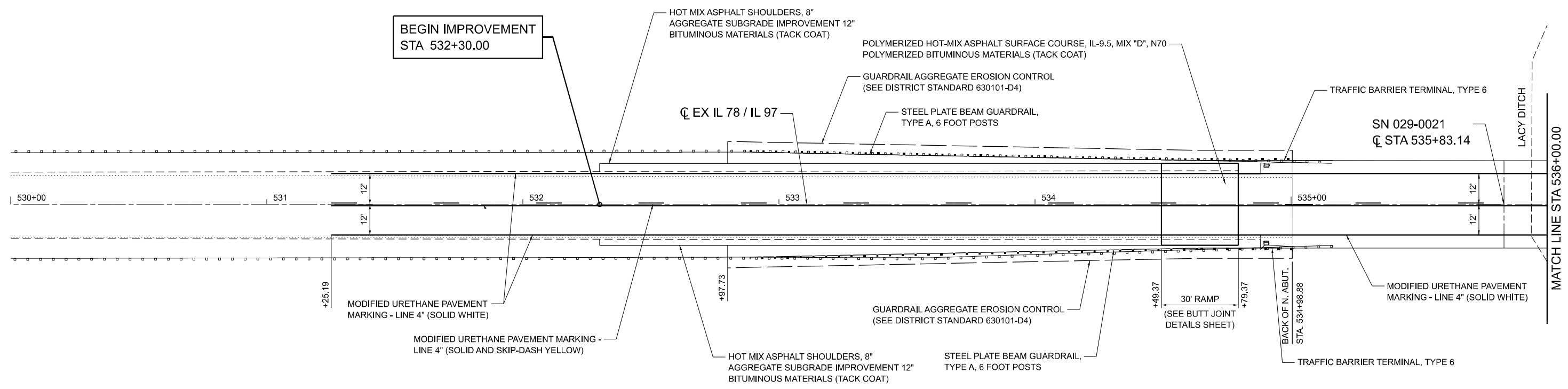
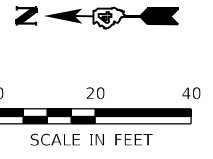

MODEL: Unnamed Plan - Plan 6 (Sheet)  
 FILE NAME: S:\2023\231006 PTB 206-30 D4 - Hurst Rosche - Various PH1 & IIWO-2 Bridge Repair Plans 68H20\CADD\CADD Sheets\68H20-sht-plan.dgn



USER NAME = rgoertz	DESIGNED - RG	REVISED -
	DRAWN - TO	REVISED -
PLOT SCALE = 0.16666833' / in.	CHECKED - SMK	REVISED -
PLOT DATE = 12/14/2023	DATE -	REVISED -

**STATE OF ILLINOIS**  
**DEPARTMENT OF TRANSPORTATION**

<b>ROADWAY PLANS</b> <b>IL 78 / IL 97 (SN 029-0021)</b>			
SCALE: 1" = 20'	SHEET 8	OF 9 SHEETS	STA. 532+30.00 TO STA. 536+00.00

F.A.P. RTE. 315/30	SECTION [139,138(BC;BC-1)BR,BR-1]BRR	COUNTY FULTON	TOTAL SHEETS 119	SHEET NO. 30
CONTRACT NO. 68H20				ILLINOIS FED. AID PROJECT

MODEL: Unnamed Plan - Plan 7 (Sheet)  
 FILE NAME: S:\2023\2311\06 PTB 206-30 D4 - Hurst Rosche - Various PH I & II\WO-2 Bridge Repair Plans 68H20\CADD\CADD Sheets\468H20-sht-plan.dgn

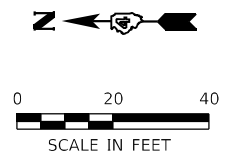
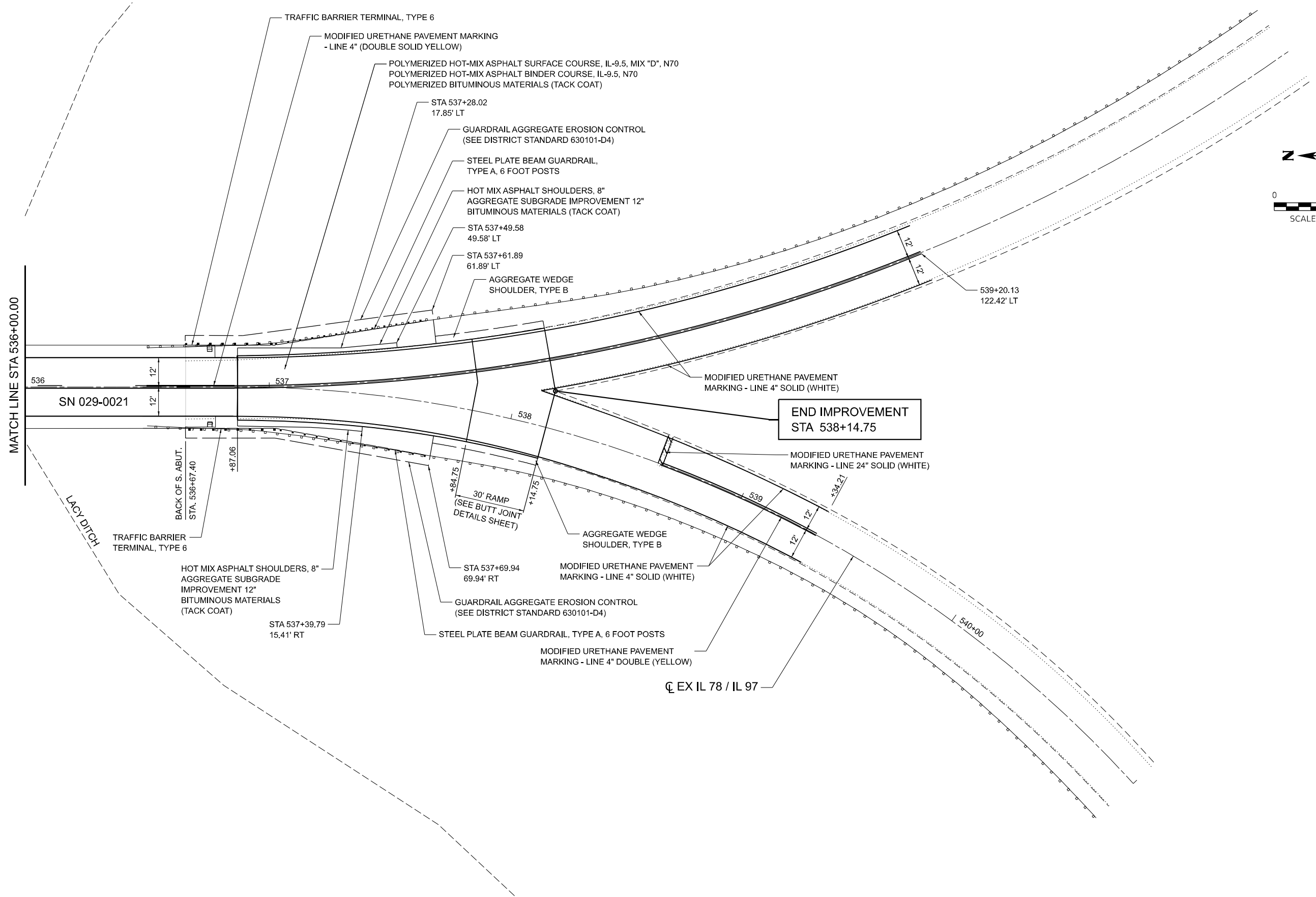

USER NAME = rgoertz	DESIGNED - RG	REVISED -
	DRAWN - TO	REVISED -
PLOT SCALE = 0.16666833' / in.	CHECKED - SMK	REVISED -
PLOT DATE = 12/14/2023	DATE -	REVISED -

STATE OF ILLINOIS  
 DEPARTMENT OF TRANSPORTATION

<b>ROADWAY PLANS</b>			
<b>IL 78 / IL 97 (SN 029-0021)</b>			
SCALE: 1" = 20'	SHEET 9	OF 9 SHEETS	STA. 536+00.00 TO STA. 537+50.00

F.A.P. RTE.	SECTION	COUNTY	TOTAL SHEETS	SHEET NO.
315/30	1139,138(BC;BC-1)BR,BR-1BRR	FULTON	119	31
CONTRACT NO. 68H20				
ILLINOIS FED. AID PROJECT				

MODEL: STAGE 1 - 1 [Sheet]  
 FILE NAME: S:\2023\231006 PTB\_206-30 D4 - Hurst Rosche - Various PH I & II\WO-2 Bridge Repair Plans 68H20\CADD\CADD Sheets\68H20-sh1-typical.dgn

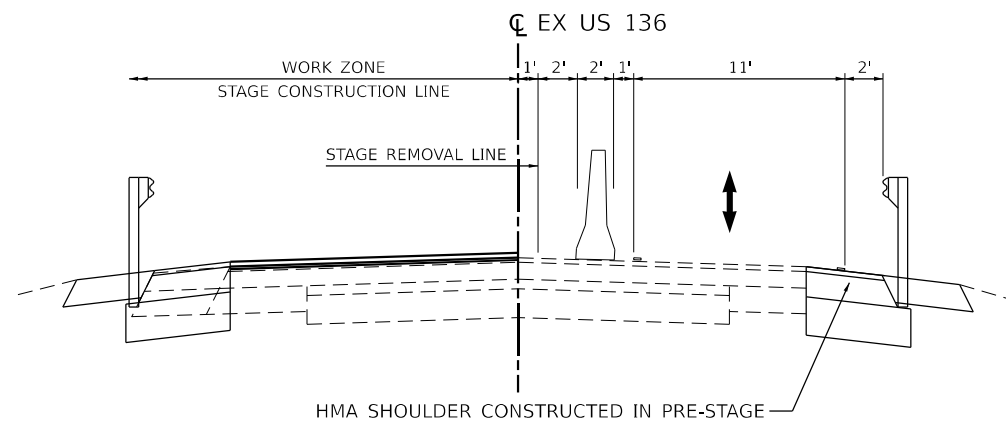

**STAGE I TYPICAL SECTION**

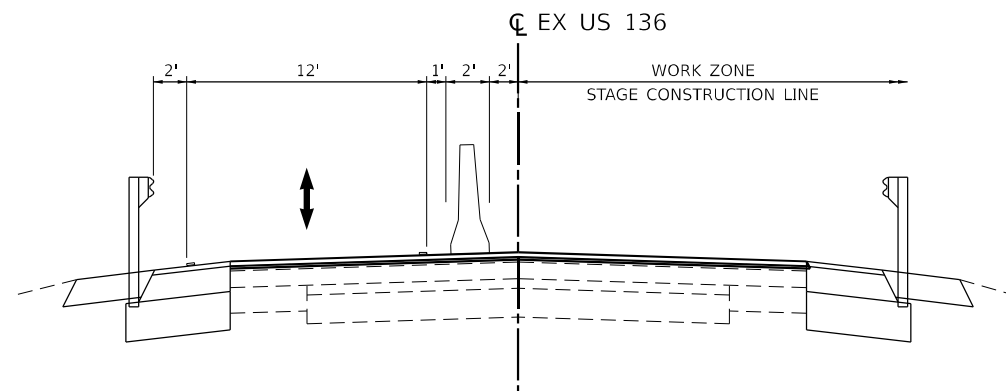

SN 029-0012  
 LOOKING EAST



**STAGE II TYPICAL SECTION**

SN 029-0012  
 LOOKING EAST

**LEGEND**

-  TEMPORARY CONCRETE BARRIER W/  
BARRIER WALL REFLECTORS, TYPE C
-  DIRECTION OF TRAFFIC

**STAGE CONSTRUCTION NOTES**

**PRE-STAGE TRAFFIC**

CLOSE EASTBOUND LANE AS REQUIRED USING HIGHWAY STANDARD 701326.

**PRE-STAGE CONSTRUCTION**

CONSTRUCT EASTBOUND SHOULDER AS DETAILED IN THE MAINTENANCE OF TRAFFIC STAGE I TYPICAL SECTION AND PLANS.

**STAGE I TRAFFIC**

CLOSE WESTBOUND LANE TRANSITIONING EASTBOUND AND WESTBOUND TRAFFIC INTO THE EASTBOUND LANE AND SHOULDER USING HIGHWAY STANDARD 701321 AND AS DETAILED IN THE MAINTENANCE OF TRAFFIC STAGE I TYPICAL SECTION AND PLANS.

**STAGE I CONSTRUCTION**

MILL PAVEMENT, BRIDGE DECK, APPROACH SLAB, AND SHOULDERS AS REQUIRED AND CONSTRUCT WESTBOUND PAVEMENT, SHOULDERS, GUARDRAIL, AND STRUCTURE REPAIRS.

**STAGE II TRAFFIC**

CLOSE EASTBOUND LANE TRANSITIONING EASTBOUND AND WESTBOUND TRAFFIC INTO THE WESTBOUND LANE AND SHOULDER USING HIGHWAY STANDARD 701321 AND AS DETAILED IN THE MAINTENANCE OF TRAFFIC STAGE II TYPICAL SECTION PLANS.

**STAGE II CONSTRUCTION**

MILL PAVEMENT, BRIDGE DECK, APPROACH SLAB, AND SHOULDERS AS REQUIRED AND CONSTRUCT EASTBOUND PAVEMENT, SHOULDERS, GUARDRAIL, AND STRUCTURE REPAIRS.

**POST-STAGE TRAFFIC**

USE HIGHWAY STANDARD 701311 FOR TRAFFIC CONTROL.

**POST-STAGE CONSTRUCTION**

CONDUCT WORKSITE CLEANUP AND PLACE FINAL PAVEMENT MARKINGS.

**WIDTH RESTRICTION SIGNAGE**

SIX (6) SETS OF WIDTH RESTRICTION SIGNS WILL BE REQUIRED. PRECISE LOCATIONS WILL BE COORDINATED AT THE PRE-CONSTRUCTION MEETING.



USER NAME = rgoertz	DESIGNED - RG	REVISED -
	DRAWN - TO	REVISED -
PLOT SCALE = 0.16666833' / in.	CHECKED - SMK	REVISED -
PLOT DATE = 12/14/2023	DATE -	REVISED -

STATE OF ILLINOIS  
 DEPARTMENT OF TRANSPORTATION

MAINTENANCE OF TRAFFIC TYPICAL SECTIONS  
 US 136 (SN029-0012)

SCALE: NONE SHEET 1 OF 5 SHEETS STA. TO STA.

F.A.P. RTE.	SECTION	COUNTY	TOTAL SHEETS	SHEET NO.
315/30	1139,138(BC;BC-1)BR,BR-1BRR	FULTON	119	32
CONTRACT NO. 68H20				
ILLINOIS FED. AID PROJECT				



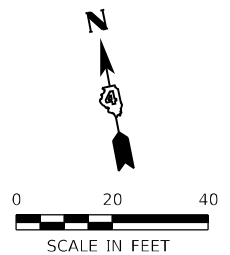

**NOTE:**  
TEMPORARY CONCRETE BARRIER CONTROL IS TO CENTER OF WALL

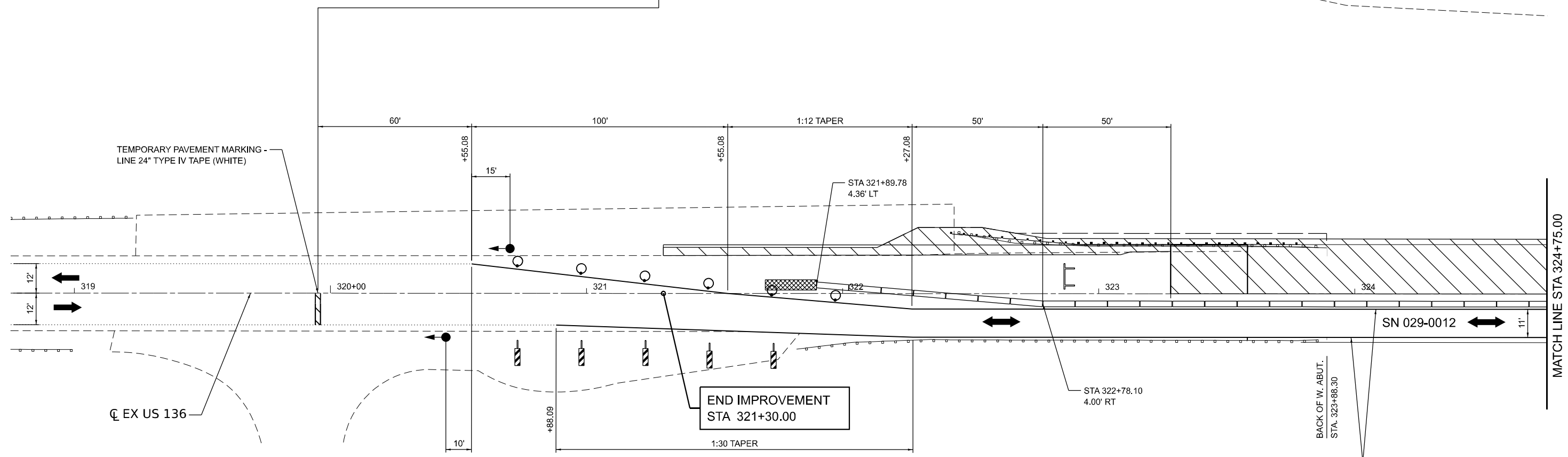
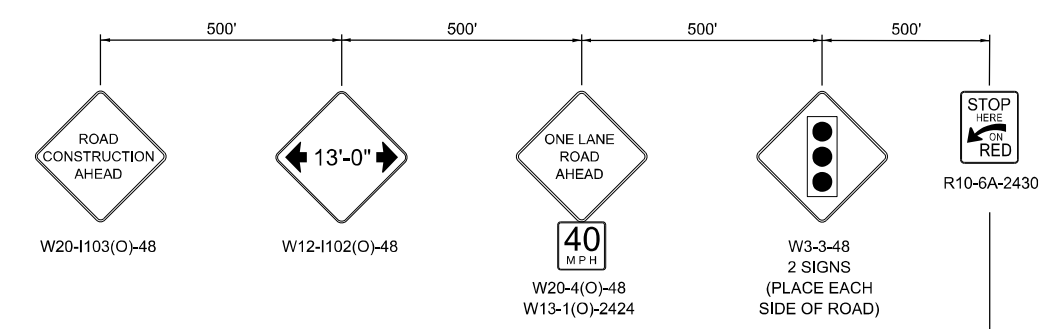

**LEGEND**

	WORK ZONE
	IMPACT ATTENUATOR
	TRAFFIC SIGN
	VERTICAL PANEL
	TEMPORARY CONCRETE BARRIER
	TYPE II BARRICADE OR DRUM WITH STEADY BURN LIGHT
	TYPE II BARRICADE WITH OR DRUM
	TYPE III BARRICADE
	DIRECTION OF TRAFFIC
	TEMPORARY TRAFFIC SIGNAL

MODEL: Unnamed Plan - Plan 11 (Sheet)  
FILE NAME: S:\2023\2311\06 PTB\_206-30 D4 - Hurst Rosche - Various PH I & II\WO-2 Bridge Repair Plans 68H20\CADD\CADD Sheets\68H20-sheeting\_01.dgn



USER NAME = rgoertz	DESIGNED - RG	REVISED -
PLOT SCALE = 0.16666833' / in.	DRAWN - TO	REVISED -
PLOT DATE = 12/14/2023	CHECKED - SMK	REVISED -
	DATE -	REVISED -

**STATE OF ILLINOIS  
DEPARTMENT OF TRANSPORTATION**

**MAINTENANCE OF TRAFFIC STAGE I PLANS  
US 136 (SN 029-0012)**

SCALE: 1" = 20'    SHEET 2 OF 5 SHEETS    STA. 321+30.00 TO STA. 324+75.00

F.A.P. RTE. 315/30	SECTION 1139,138(BC,BC-1)BR,BR-1)BRR	COUNTY FULTON	TOTAL SHEETS 119	SHEET NO. 33
ILLINOIS FED. AID PROJECT			CONTRACT NO. 68H20	

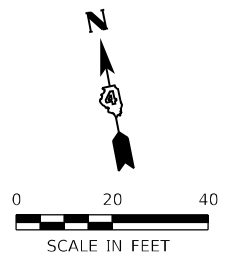

**NOTE:**  
TEMPORARY CONCRETE BARRIER CONTROL IS TO CENTER OF WALL

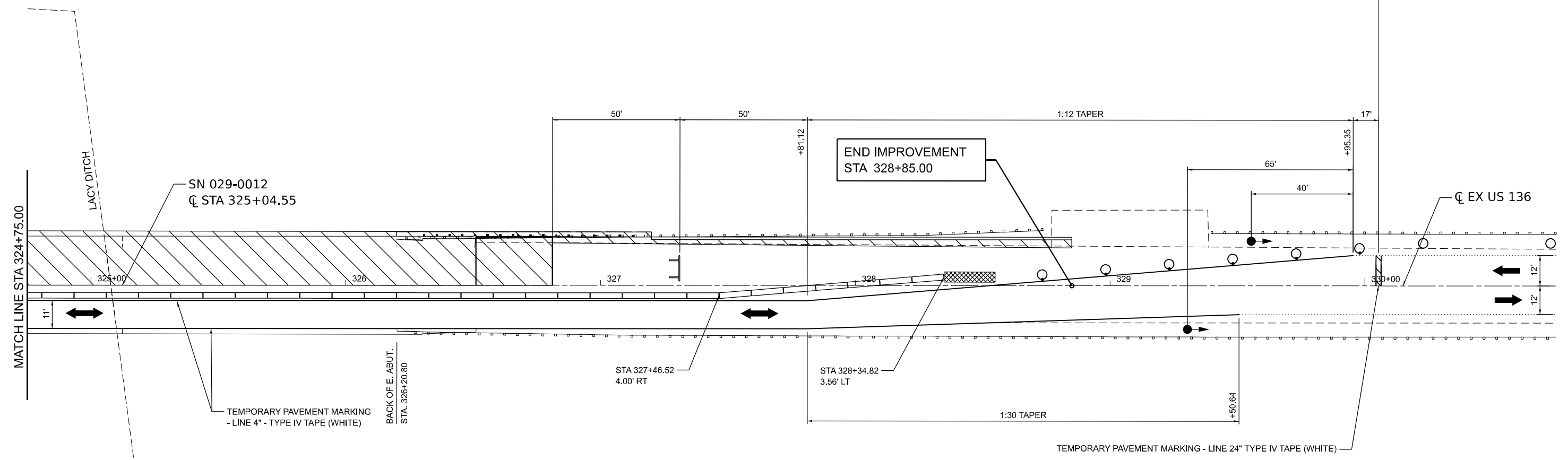
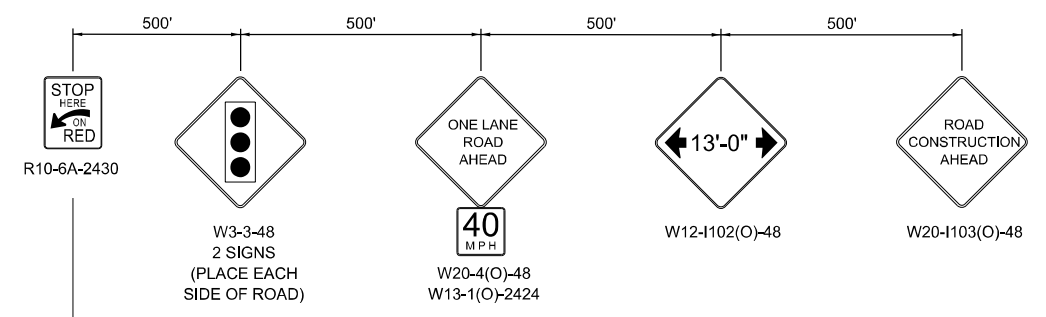

**LEGEND**

- WORK ZONE
- IMPACT ATTENUATOR
- TRAFFIC SIGN
- VERTICAL PANEL
- TEMPORARY CONCRETE BARRIER
- TYPE II BARRICADE OR DRUM WITH STEADY BURN LIGHT
- TYPE II BARRICADE WITH OR DRUM
- TYPE III BARRICADE
- DIRECTION OF TRAFFIC
- TEMPORARY TRAFFIC SIGNAL

MODEL: Unnamed Plan - Plan 12 (Sheet)  
FILE NAME: S:\2023\2311\06\PTB\206-30 D4 - Hurst Rosche - Various PH I & II\WO-2 Bridge Repair Plans 68H20\CADD\CADD Sheets\68H20-shtestaging\_01.dgn



USER NAME = rgoertz	DESIGNED - RG	REVISED -
DRAWN - TO	DRAWN - TO	REVISED -
PLOT SCALE = 0.16666633' / in.	CHECKED - SMK	REVISED -
PLOT DATE = 12/14/2023	DATE -	REVISED -

**STATE OF ILLINOIS  
DEPARTMENT OF TRANSPORTATION**

**MAINTENANCE OF TRAFFIC STAGE I PLANS  
US 136 (SN 029-0012)**

SCALE: 1" = 20'    SHEET 3 OF 5 SHEETS    STA. 324+75.00 TO STA. 328+85.00

F.A.P. RTE.	SECTION	COUNTY	TOTAL SHEETS	SHEET NO.
315/30	1139,138(BC;BC-1)BR,BR-1)BRR	FULTON	119	34
CONTRACT NO. 68H20				
ILLINOIS FED. AID PROJECT				

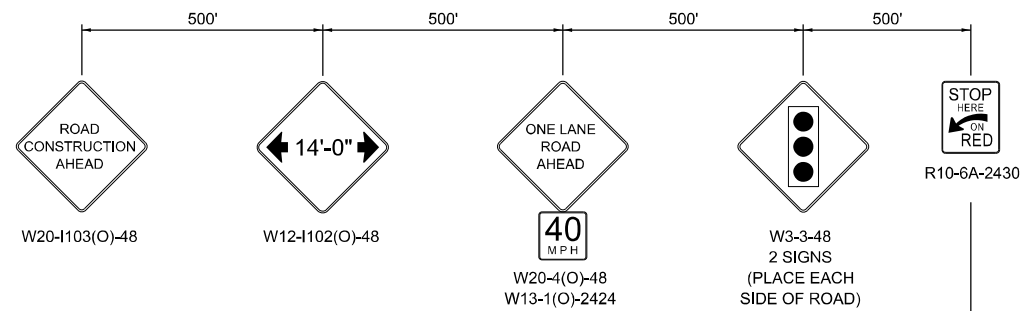

**NOTE:**  
TEMPORARY CONCRETE BARRIER CONTROL IS TO CENTER OF WALL

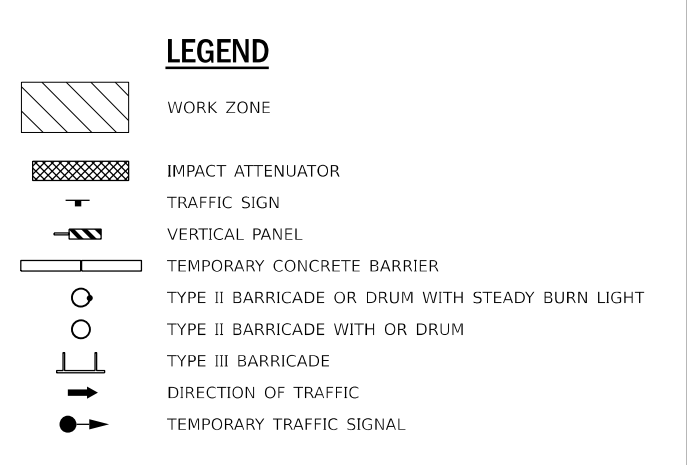
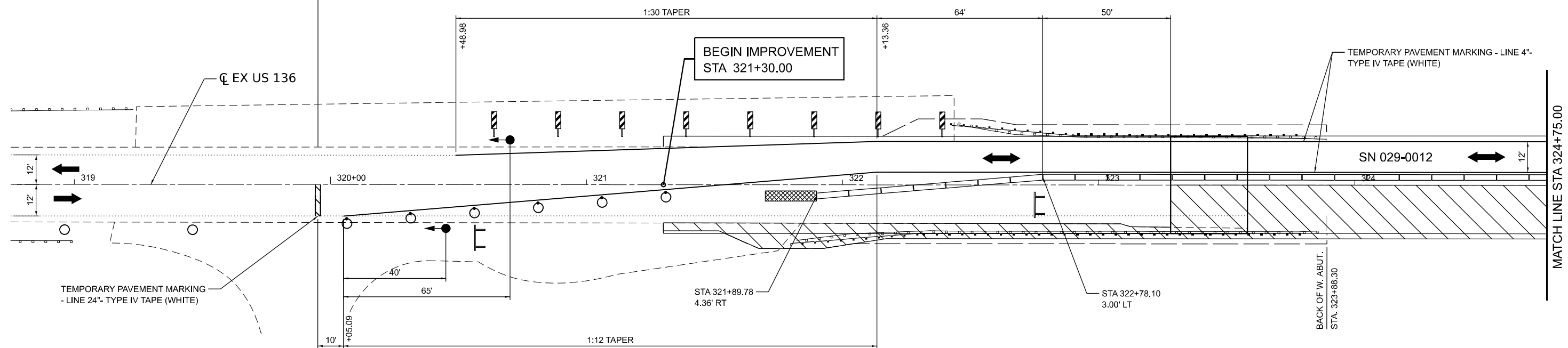

MODEL: Unnamed Plan - Plan 11 (Sheet)  
FILE NAME: S:\2023\2311\06 PTB\_206-30\_D4 - Hurst Rosche - Various PH I & II\WO-2 Bridge Repair Plans 68H20\CADD\CADD Sheets\68H20-shrestaging\_02.dgn



USER NAME = toverton	DESIGNED - RG	REVISED -
DRAWN - TO	REVISED -	
PLOT SCALE = 0.16666633' / in.	CHECKED - SMK	REVISED -
PLOT DATE = 12/14/2023	DATE -	REVISED -

**STATE OF ILLINOIS  
DEPARTMENT OF TRANSPORTATION**

**MAINTENANCE OF TRAFFIC STAGE II PLANS  
US 136 (SN 029-0012)**

SCALE: 1" = 20'    SHEET 4 OF 5 SHEETS    STA. 321+30.00 TO STA. 324+75.00

F.A.P. RTE.	SECTION	COUNTY	TOTAL SHEETS	SHEET NO.
315/30	1139,138(BC,BC-1)BR,BR-1)BRR	FULTON	119	35
CONTRACT NO. 68H20				
ILLINOIS FED. AID PROJECT				

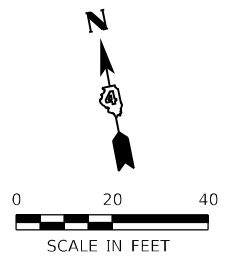

**NOTE:**  
 TEMPORARY CONCRETE BARRIER CONTROL  
 IS TO CENTER OF WALL

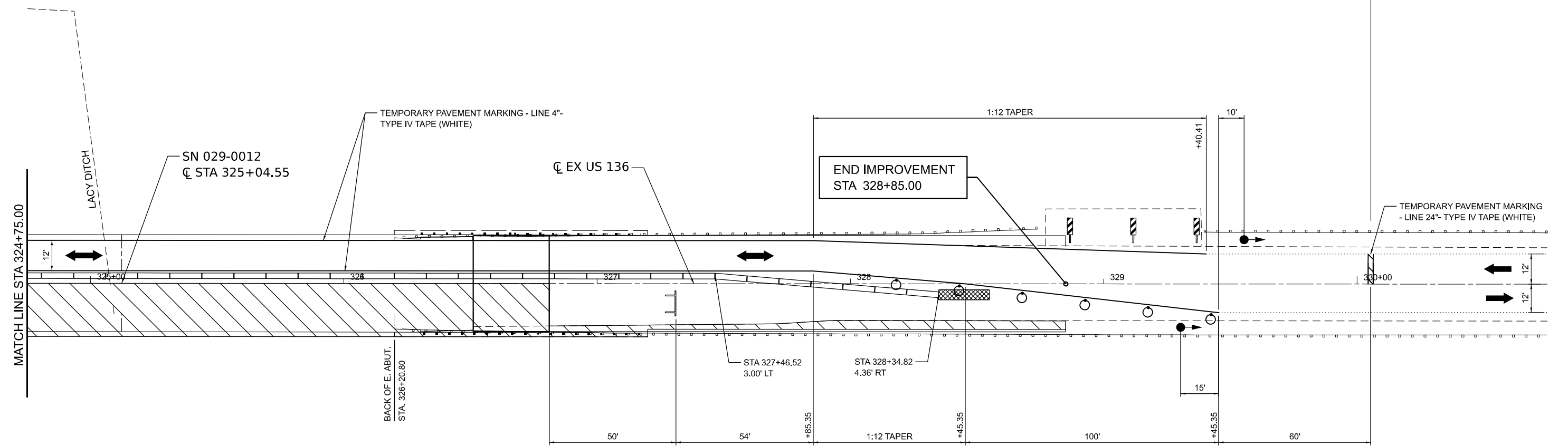
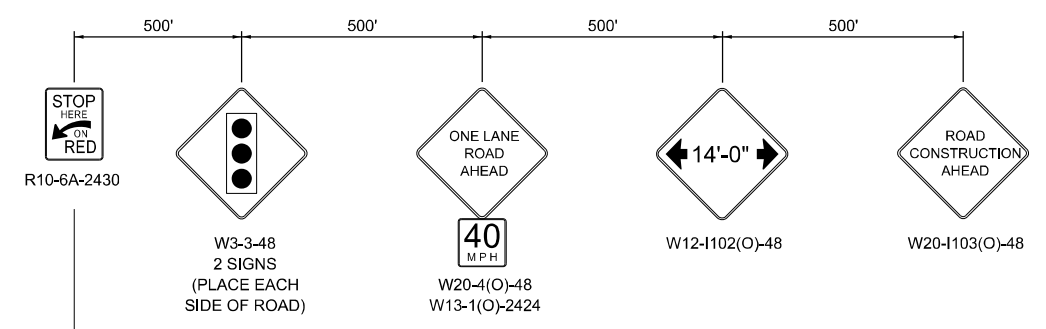

**LEGEND**

	WORK ZONE
	IMPACT ATTENUATOR
	TRAFFIC SIGN
	VERTICAL PANEL
	TEMPORARY CONCRETE BARRIER
	TYPE II BARRICADE OR DRUM WITH STEADY BURN LIGHT
	TYPE II BARRICADE WITH OR DRUM
	TYPE III BARRICADE
	DIRECTION OF TRAFFIC
	TEMPORARY TRAFFIC SIGNAL

MODEL: Unnamed Plan - Plan 12 (Sheet)  
 FILE NAME: S:\2023\231006 PTE\206-30 D4 - Hurst Rosche - Various PH I & II\WO-2 Bridge Repair Plans 68H20\CADD\CADD Sheets\68H20-sheeting\_02.dgn



USER NAME = rgoertz	DESIGNED - RG	REVISED -
PLOT SCALE = 0.16666833' / in.	DRAWN - TO	REVISED -
PLOT DATE = 12/14/2023	CHECKED - SMK	REVISED -
	DATE -	REVISED -

**STATE OF ILLINOIS  
 DEPARTMENT OF TRANSPORTATION**

**MAINTENANCE OF TRAFFIC STAGE II PLANS  
 US 136 (SN 029-0012)**

SCALE: 1" = 20'    SHEET 5 OF 5 SHEETS    STA. 324+75.00 TO STA. 328+85.00

F.A.P. RTE. 315/30	SECTION 1139,138(BC,BC-1)BR,BR-1)BRR	COUNTY FULTON	TOTAL SHEETS 119	SHEET NO. 36
CONTRACT NO. 68H20				
ILLINOIS FED. AID PROJECT				

MODEL: STAGE 2 - 1 [Sheet]  
 FILE NAME: S:\2023\231006 PTB\_206-30 D4 - Hurst Rosche - Various PH I & II\WO-2 Bridge Repair Plans 68H20\CADD\CADD Sheets\68H20-sh2-typical.dgn

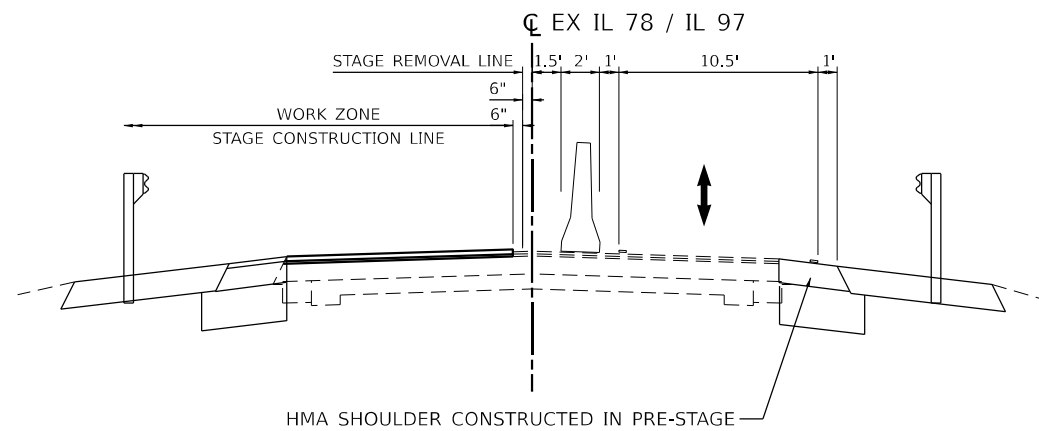

**STAGE I TYPICAL SECTION**

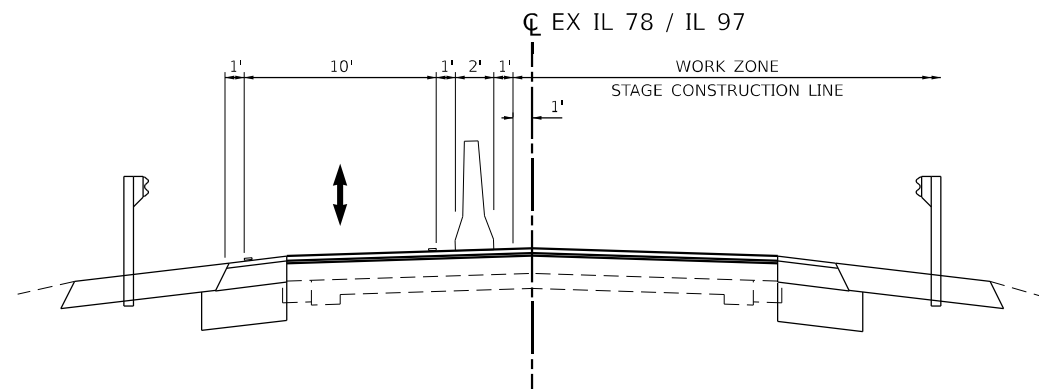

SN 029-0055  
 LOOKING SOUTH



**STAGE II TYPICAL SECTION**

SN 029-0055  
 LOOKING SOUTH

**LEGEND**

-  TEMPORARY CONCRETE BARRIER W/  
BARRIER WALL REFLECTORS, TYPE C
-  DIRECTION OF TRAFFIC

**STAGE CONSTRUCTION NOTES**

**PRE-STAGE TRAFFIC**

CLOSE SOUTHBOUND LANE AS REQUIRED USING HIGHWAY STANDARD 701326.

**PRE-STAGE CONSTRUCTION**

CONSTRUCT SOUTHBOUND SHOULDER AS DETAILED IN THE MAINTENANCE OF TRAFFIC STAGE I TYPICAL SECTION AND PLANS.

**STAGE I TRAFFIC**

CLOSE NORTHBOUND LANE TRANSITIONING NORTHBOUND AND SOUTHBOUND TRAFFIC INTO THE SOUTHBOUND LANE AND SHOULDER USING HIGHWAY STANDARD 701321 AND AS DETAILED IN THE MAINTENANCE OF TRAFFIC STAGE I TYPICAL SECTION AND PLANS.

**STAGE I CONSTRUCTION**

MILL PAVEMENT, BRIDGE DECK, APPROACH SLAB, AND SHOULDERS AS REQUIRED AND CONSTRUCT NORTHBOUND PAVEMENT, SHOULDERS, GUARDRAIL, AND STRUCTURE REPAIRS.

**STAGE II TRAFFIC**

CLOSE SOUTHBOUND LANE TRANSITIONING NORTHBOUND AND SOUTHBOUND TRAFFIC INTO THE NORTHBOUND LANE AND SHOULDER USING HIGHWAY STANDARD 701321 AND AS DETAILED IN THE MAINTENANCE OF TRAFFIC STAGE II TYPICAL SECTION PLANS.

**STAGE II CONSTRUCTION**

MILL PAVEMENT, BRIDGE DECK, APPROACH SLAB, AND SHOULDERS AS REQUIRED AND CONSTRUCT SOUTHBOUND PAVEMENT, SHOULDERS, GUARDRAIL, AND STRUCTURE REPAIRS.

**POST-STAGE TRAFFIC**

USE HIGHWAY STANDARD 701311 FOR TRAFFIC CONTROL.

**POST-STAGE CONSTRUCTION**

CONDUCT WORKSITE CLEANUP AND PLACE FINAL PAVEMENT MARKINGS.

**WIDTH RESTRICTION SIGNAGE**

SIX (6) SETS OF WIDTH RESTRICTION SIGNS WILL BE REQUIRED. PRECISE LOCATIONS WILL BE COORDINATED AT THE PRE-CONSTRUCTION MEETING.



USER NAME = rgoertz	DESIGNED - RG	REVISED -
	DRAWN - TO	REVISED -
PLOT SCALE = 0.16666833' / in.	CHECKED - SMK	REVISED -
PLOT DATE = 12/14/2023	DATE -	REVISED -

STATE OF ILLINOIS  
 DEPARTMENT OF TRANSPORTATION

MAINTENANCE OF TRAFFIC TYPICAL SECTIONS  
 IL 78 / IL 97 (SN 029-0055)

SCALE: NONE SHEET 1 OF 5 SHEETS STA. TO STA.

F.A.P. RTE.	SECTION	COUNTY	TOTAL SHEETS	SHEET NO.
315/30	1139,138(BC;BC-1)BR,BR-1BRR	FULTON	119	37
CONTRACT NO. 68H20				
ILLINOIS FED. AID PROJECT				

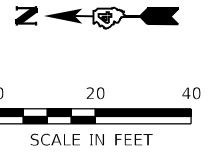

**NOTE:**

TEMPORARY CONCRETE BARRIER CONTROL IS TO CENTER OF WALL

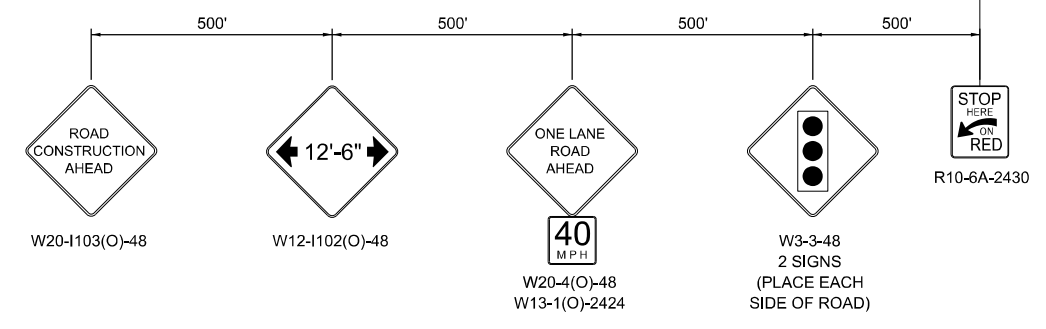
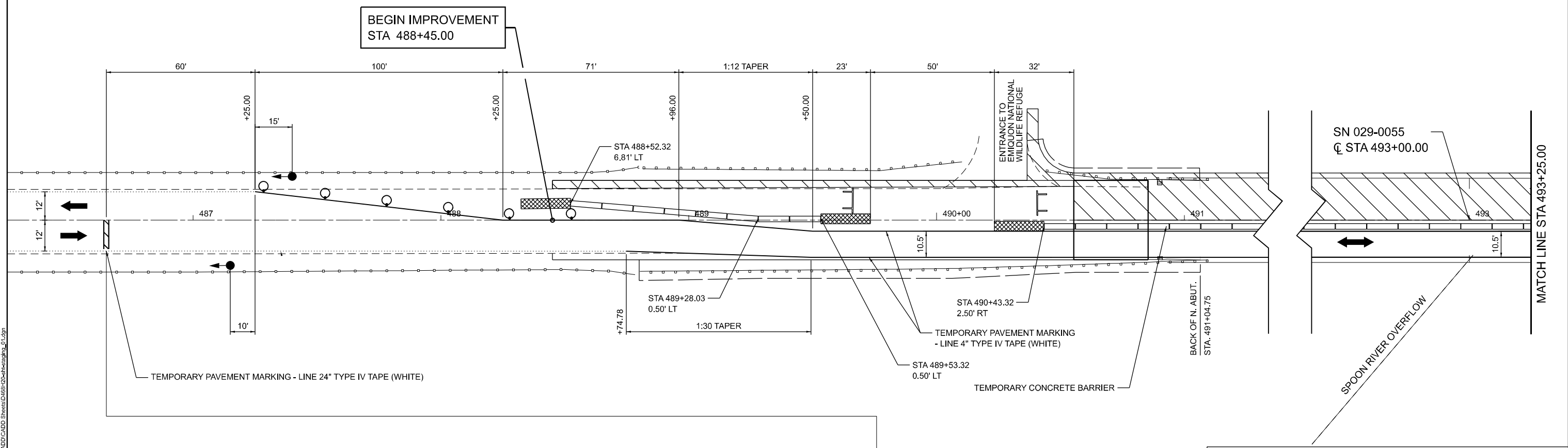

**LEGEND**

- WORK ZONE
- IMPACT ATTENUATOR
- TRAFFIC SIGN
- VERTICAL PANEL
- TEMPORARY CONCRETE BARRIER
- TYPE II BARRICADE OR DRUM WITH STEADY BURN LIGHT
- TYPE II BARRICADE WITH OR DRUM
- TYPE III BARRICADE
- DIRECTION OF TRAFFIC
- TEMPORARY TRAFFIC SIGNAL

MODEL: Unnamed (Plan - File) (Sheet)  
 FILE NAME: S:\2023\21009\_PTB 2023\04 - Hurst Roache - Various PH1 & IIVC2 Bridge Repair Plans 68H20CADD\CADD\_Sheet\488+45-493+25.dwg\_01.dwg



USER NAME = rgoertz	DESIGNED - RG	REVISED -
PLOT SCALE = 0.16666833' / in.	DRAWN - TO	REVISED -
PLOT DATE = 12/15/2023	CHECKED - SMK	REVISED -
	DATE -	REVISED -

**STATE OF ILLINOIS**  
**DEPARTMENT OF TRANSPORTATION**

**MAINTENANCE OF TRAFFIC STAGE I PLANS**  
**IL 78 / IL 97 (SN (029-0055))**

SCALE: 1" = 20'    SHEET 2 OF 5 SHEETS    STA. 488+45.00 TO STA. 493+25.00

F.A.P. RTE.	SECTION	COUNTY	TOTAL SHEETS	SHEET NO.
315/30	1139,138(BC-1)BR, BR-1(BRR)	FULTON	119	38
CONTRACT NO. 68H20			ILLINOIS FED. AID PROJECT	

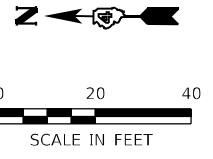

**NOTE:**  
TEMPORARY CONCRETE BARRIER CONTROL IS TO CENTER OF WALL

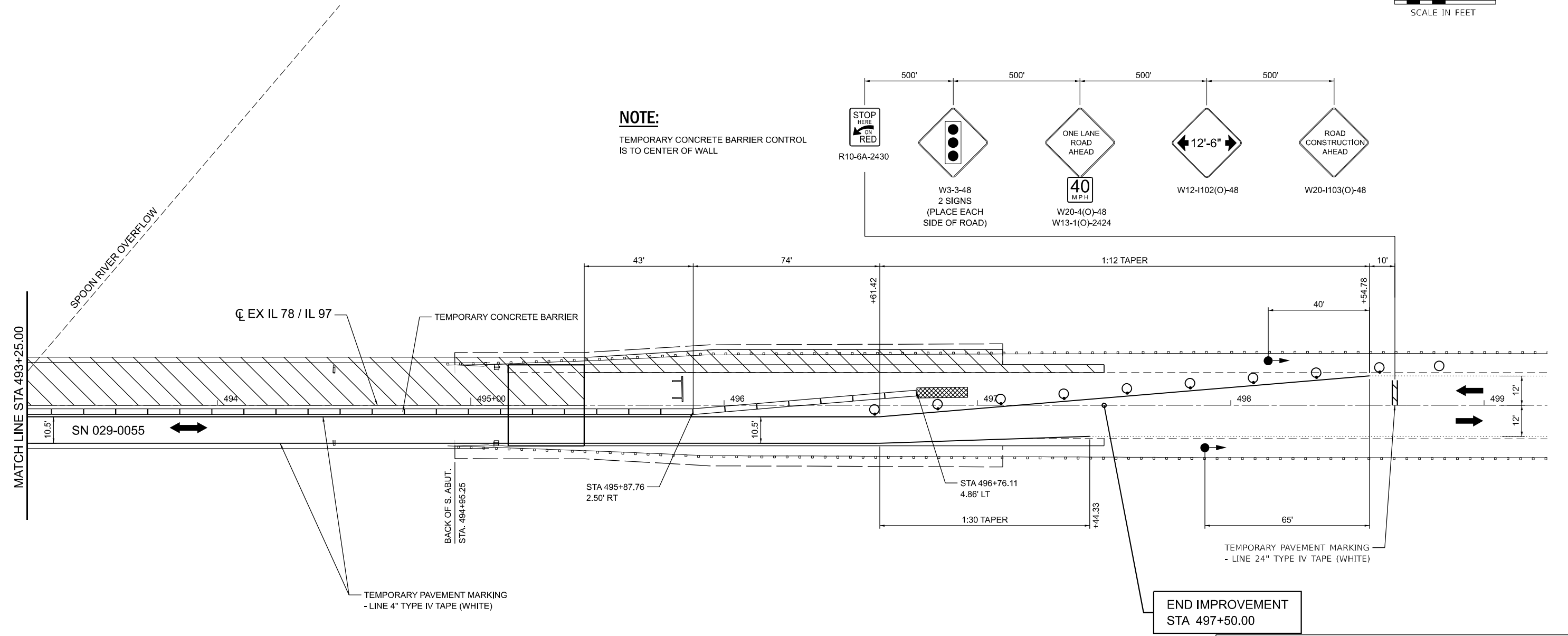
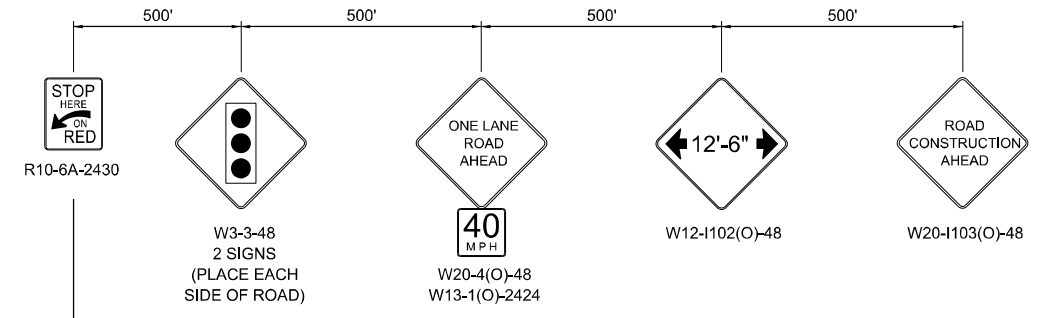

**END IMPROVEMENT  
STA 497+50.00**

**LEGEND**

- WORK ZONE
- IMPACT ATTENUATOR
- VERTICAL PANEL
- TEMPORARY CONCRETE BARRIER
- TYPE II BARRICADE OR DRUM WITH STEADY BURN LIGHT
- TYPE II BARRICADE WITH OR DRUM
- TYPE III BARRICADE
- DIRECTION OF TRAFFIC
- TEMPORARY TRAFFIC SIGNAL

MODEL: Unnamed (Plan) - Sheet 4 (Sheet) FILE NAME: S:\2023\21009\_PTB 2023\04 - Hurst Roache - Various PH1 & IIVC2 Bridge Repair Plans 68H20CAD\CAD Sheets\68H20-4-Subarea\_01.dgn  
 QUIGG ENGINEERING INC



USER NAME = rgoertz	DESIGNED - RG	REVISED -
DRAWN - TO	REVISED -	
PLOT SCALE = 0.16666633' / in.	CHECKED - SMK	REVISED -
PLOT DATE = 12/15/2023	DATE -	REVISED -

**STATE OF ILLINOIS  
DEPARTMENT OF TRANSPORTATION**

<b>MAINTENANCE OF TRAFFIC STAGE I PLANS</b>			
<b>IL 78 / IL 97 (SN 029-0055)</b>			
SCALE: 1" = 20'	SHEET 3	OF 5 SHEETS	TO STA. 497+50.00

F.A.P. RTE. 315/30	SECTION 1139,138(BC,BC-1)BR,BR-1BRR	COUNTY FULTON	TOTAL SHEETS 119	SHEET NO. 39
CONTRACT NO. 68H20				
ILLINOIS FED. AID PROJECT				

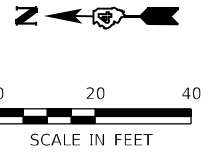

**NOTE:**

TEMPORARY CONCRETE BARRIER CONTROL IS TO CENTER OF WALL

BEGIN IMPROVEMENT  
STA 488+50.00

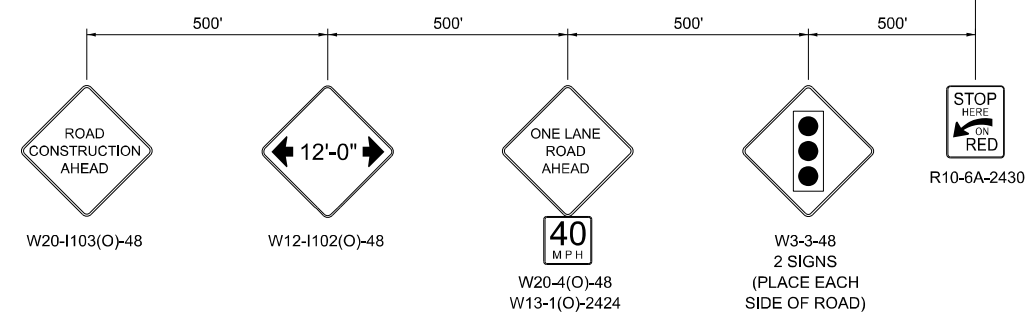
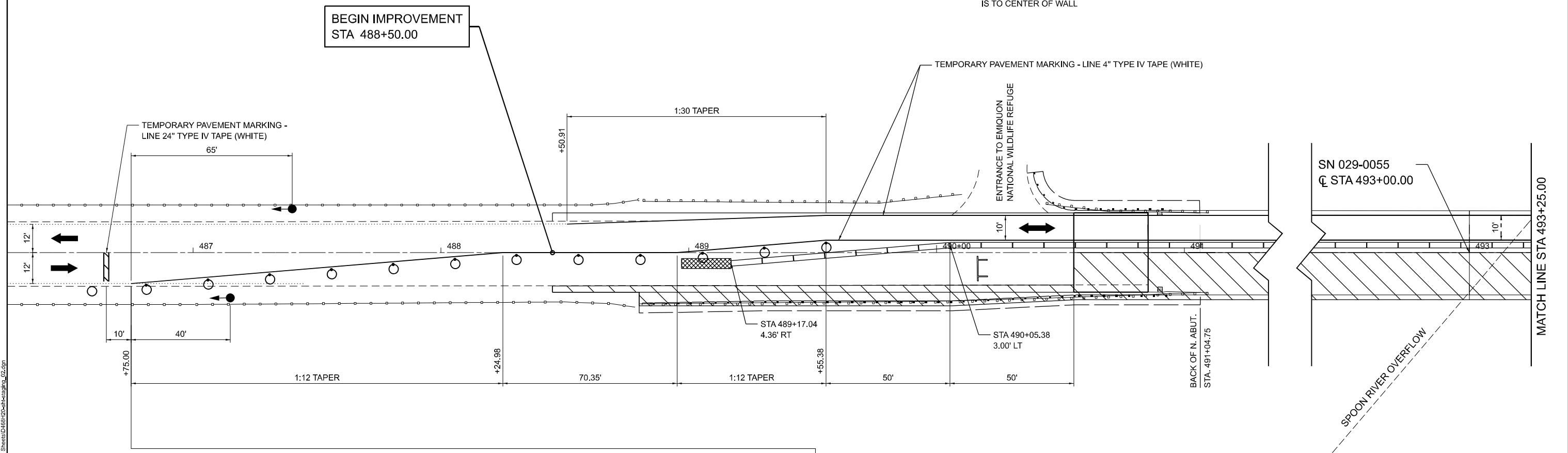

**LEGEND**

- WORK ZONE
- IMPACT ATTENUATOR
- TRAFFIC SIGN
- VERTICAL PANEL
- TEMPORARY CONCRETE BARRIER
- TYPE II BARRICADE OR DRUM WITH STEADY BURN LIGHT
- TYPE II BARRICADE WITH OR DRUM
- TYPE III BARRICADE
- DIRECTION OF TRAFFIC
- TEMPORARY TRAFFIC SIGNAL

MODEL: Unsaved (Plan) - File (Sheet)  
 FILE NAME: S:\2023\21\LOG PTB 20230.D4 - Hurst Roache - Various PH1 & IIVC2 Bridge Repair Plans 68H20CADD\CADD\_Sheet\488H20-491H20.dwg



USER NAME = rgoertz	DESIGNED - RG	REVISED -
PLOT SCALE = 0.16666833' / in.	DRAWN - TO	REVISED -
PLOT DATE = 12/15/2023	CHECKED - SMK	REVISED -
	DATE -	REVISED -

**STATE OF ILLINOIS  
DEPARTMENT OF TRANSPORTATION**

**MAINTENANCE OF TRAFFIC STAGE II PLANS  
IL 78 / IL 97 (SN 029-0055)**

SCALE: 1" = 20'    SHEET 4 OF 5 SHEETS    STA. 488+50.00 TO STA. 493+25.00

F.A.P. RTE.	SECTION	COUNTY	TOTAL SHEETS	SHEET NO.
315/30	1139,138(BC,BC-1)BR,BR-1(BRR)	FULTON	119	40
CONTRACT NO. 68H20			ILLINOIS FED. AID PROJECT	





MODEL: 029-0056 - 029-0056 (Sheet)  
 FILE NAME: S:\2023\231106 FTB 206-30 D4 - Hurst Rosche - Various PH I & II\WO-2 Bridge Repair Plans 68H20\CADD\CADD Sheets\0468H20-sh1-typical.dgn

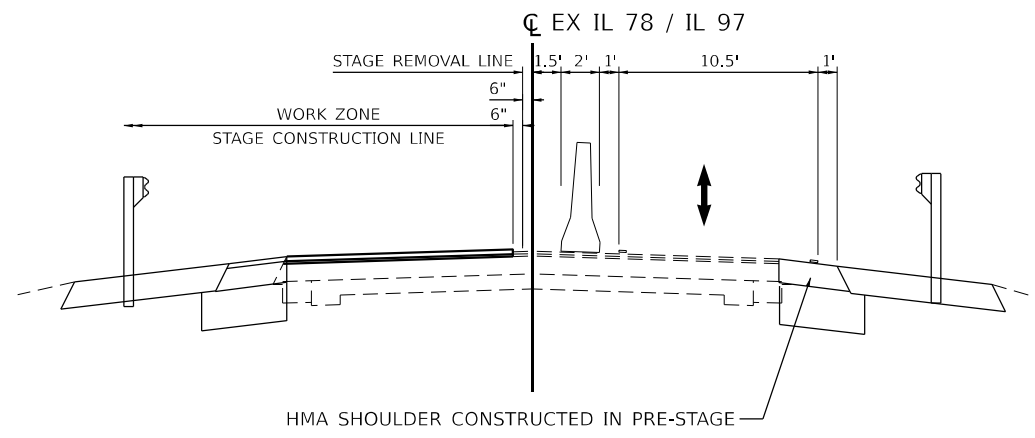

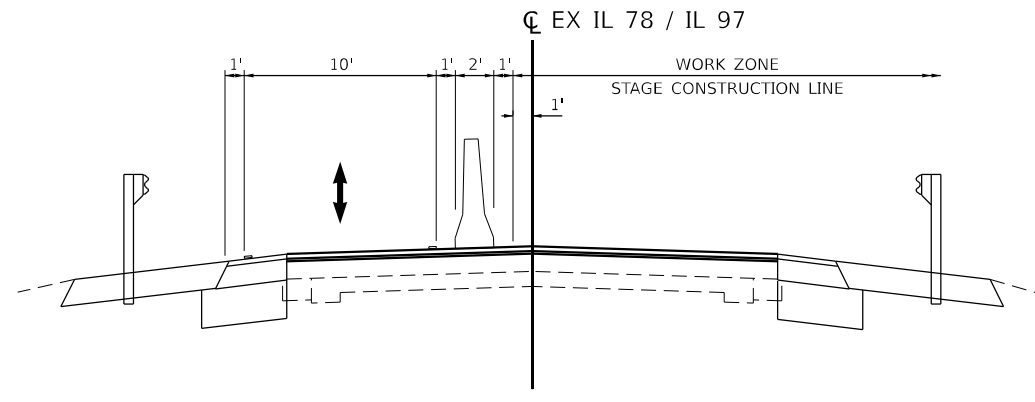

**STAGE I TYPICAL SECTION**  
 SN 029-0056  
 LOOKING SOUTH



**STAGE II TYPICAL SECTION**  
 SN 029-0056  
 LOOKING SOUTH

**LEGEND**

-  TEMPORARY CONCRETE BARRIER W/  
BARRIER WALL REFLECTORS, TYPE C
-  DIRECTION OF TRAFFIC

**STAGE CONSTRUCTION NOTES**

**PRE-STAGE TRAFFIC**

CLOSE SOUTHBOUND LANE AS REQUIRED USING HIGHWAY STANDARD 701326.

**PRE-STAGE CONSTRUCTION**

CONSTRUCT SOUTHBOUND SHOULDER AS DETAILED IN THE MAINTENANCE OF TRAFFIC STAGE I TYPICAL SECTION AND PLANS.

**STAGE I TRAFFIC**

CLOSE NORTHBOUND LANE TRANSITIONING NORTHBOUND AND SOUTHBOUND TRAFFIC INTO THE SOUTHBOUND LANE AND SHOULDER USING HIGHWAY STANDARD 701321 AND AS DETAILED IN THE MAINTENANCE OF TRAFFIC STAGE I TYPICAL SECTION AND PLANS.

**STAGE I CONSTRUCTION**

MILL PAVEMENT, BRIDGE DECK, APPROACH SLAB, AND SHOULDERS AS REQUIRED AND CONSTRUCT NORTHBOUND PAVEMENT, SHOULDERS, GUARDRAIL, AND STRUCTURE REPAIRS.

**STAGE II TRAFFIC**

CLOSE SOUTHBOUND LANE TRANSITIONING NORTHBOUND AND SOUTHBOUND TRAFFIC INTO THE NORTHBOUND LANE AND SHOULDER USING HIGHWAY STANDARD 701321 AND AS DETAILED IN THE MAINTENANCE OF TRAFFIC STAGE II TYPICAL SECTION PLANS.

**STAGE II CONSTRUCTION**

MILL PAVEMENT, BRIDGE DECK, APPROACH SLAB, AND SHOULDERS AS REQUIRED AND CONSTRUCT SOUTHBOUND PAVEMENT, SHOULDERS, GUARDRAIL, AND STRUCTURE REPAIRS.

**POST-STAGE TRAFFIC**

USE HIGHWAY STANDARD 701311 FOR TRAFFIC CONTROL.

**POST-STAGE CONSTRUCTION**

CONDUCT WORKSITE CLEANUP AND PLACE FINAL PAVEMENT MARKINGS.

**WIDTH RESTRICTION SIGNAGE**

SIX (6) SETS OF WIDTH RESTRICTION SIGNS WILL BE REQUIRED. PRECISE LOCATIONS WILL BE COORDINATED AT THE PRE-CONSTRUCTION MEETING.



USER NAME = rgoertz	DESIGNED - RG	REVISED -
PLOT SCALE = 0.16666833' / in.	DRAWN - TO	REVISED -
PLOT DATE = 12/14/2023	CHECKED - SMK	REVISED -
	DATE -	REVISED -

**STATE OF ILLINOIS  
 DEPARTMENT OF TRANSPORTATION**

**MAINTENANCE OF TRAFFIC TYPICAL SECTIONS  
 IL 78 / IL 97 (SN 029-0056)**

SCALE: NONE SHEET 1 OF 7 SHEETS STA. TO STA.

F.A.P. RTE.	SECTION	COUNTY	TOTAL SHEETS	SHEET NO.
315/30	1139,138(BC;BC-1)BR,BR-1)BRR	FULTON	119	42
CONTRACT NO. 68H20				
ILLINOIS FED. AID PROJECT				

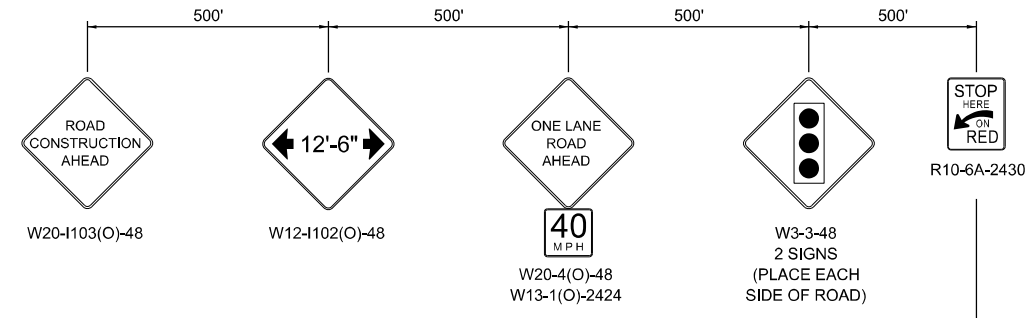
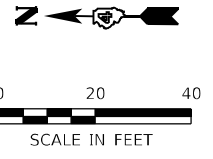

**NOTE:**  
TEMPORARY CONCRETE BARRIER CONTROL IS TO CENTER OF WALL

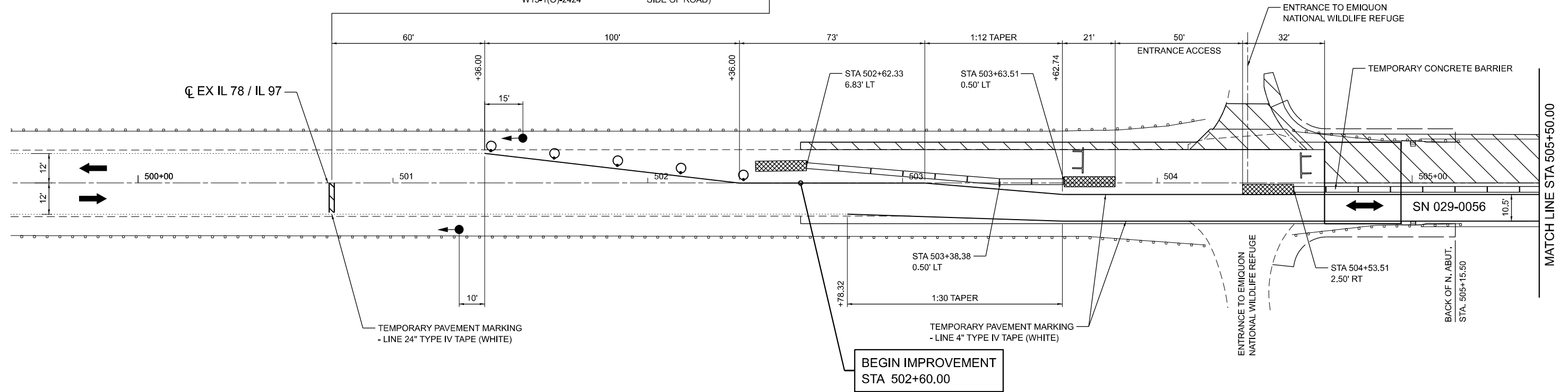

**LEGEND**

- WORK ZONE
- IMPACT ATTENUATOR
- VERTICAL PANEL
- TEMPORARY CONCRETE BARRIER
- TYPE II BARRICADE OR DRUM WITH STEADY BURN LIGHT
- TYPE II BARRICADE WITH OR DRUM
- TYPE III BARRICADE
- DIRECTION OF TRAFFIC
- TEMPORARY TRAFFIC SIGNAL

MODEL: Unnamed (Plan) - File 3 (Sheet)  
 FILE NAME: S:\2023\21009\_PTB 202301.D4 - Hurst Roache - Various PH1 & IIVC2 Bridge Repair Plans 68H20CAD00\_CADD\_Sheet\0468H20-4-Subarea\_01.dgn



USER NAME = rgoertz	DESIGNED - RG	REVISED -
PLOT SCALE = 0.16666633' / in.	DRAWN - TO	REVISED -
PLOT DATE = 12/15/2023	CHECKED - SMK	REVISED -
	DATE -	REVISED -

**STATE OF ILLINOIS  
DEPARTMENT OF TRANSPORTATION**

<b>MAINTENANCE OF TRAFFIC STAGE I PLANS</b>			
<b>IL 78 / 97 (SN 029-0056)</b>			
SCALE: 1" = 20'	SHEET 2	OF 7 SHEETS	STA. 502+60.00 TO STA. 505+50.00

F.A.P. RTE. 315/30	SECTION 1139,138(BC,BC-1)BR,BR-1)BR	COUNTY FULTON	TOTAL SHEETS 119	SHEET NO. 43
CONTRACT NO. 68H20			ILLINOIS FED. AID PROJECT	

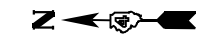





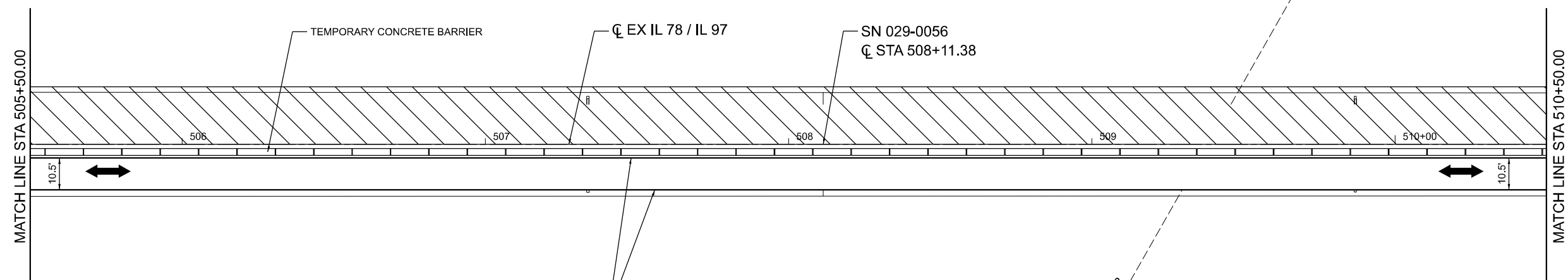

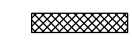

**NOTE:**

TEMPORARY CONCRETE BARRIER CONTROL IS TO CENTER OF WALL

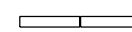

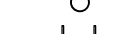
TEMPORARY PAVEMENT MARKING  
- LINE 4" TYPE IV TAPE (WHITE)

**LEGEND**

-  WORK ZONE
-  IMPACT ATTENUATOR
-  TRAFFIC SIGN
-  VERTICAL PANEL
-  TEMPORARY CONCRETE BARRIER
-  TYPE II BARRICADE OR DRUM WITH STEADY BURN LIGHT
-  TYPE II BARRICADE WITH OR DRUM
-  TYPE III BARRICADE
-  DIRECTION OF TRAFFIC
-  TEMPORARY TRAFFIC SIGNAL

MODEL: Unnamed (Plan) - File 0 (Sheet)  
FILE NAME: S:\2023\21009\21009\_PTB 2023\04 - Hurst Roache - Various PH1 & II\WC2 Bridge Repair Plans 68H20\CAD\CADD\_Sheet\21009\_PTB 2023\21009\_PTB 2023.dwg



USER NAME = rgoertz	DESIGNED - RG	REVISED -
DRAWN - TO	CHECKED - SMK	REVISED -
PLOT SCALE = 0.16666633' / in.	DATE -	REVISED -
PLOT DATE = 12/15/2023		

**STATE OF ILLINOIS  
DEPARTMENT OF TRANSPORTATION**

**MAINTENANCE OF TRAFFIC STAGE I PLANS  
IL 78 / IL 97 (SN 029-0056)**

F.A.P. RTE.	SECTION	COUNTY	TOTAL SHEETS	SHEET NO.
315/30	1139,138(BC;BC-1)BR,BR-1BRR	FULTON	119	44
CONTRACT NO. 68H20				
ILLINOIS FED. AID PROJECT				

SCALE: 1" = 20' SHEET 3 OF 7 SHEETS STA. 505+50.00 TO STA. 510+50.00

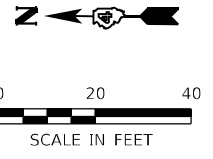

**NOTE:**  
 TEMPORARY CONCRETE BARRIER CONTROL IS TO CENTER OF WALL

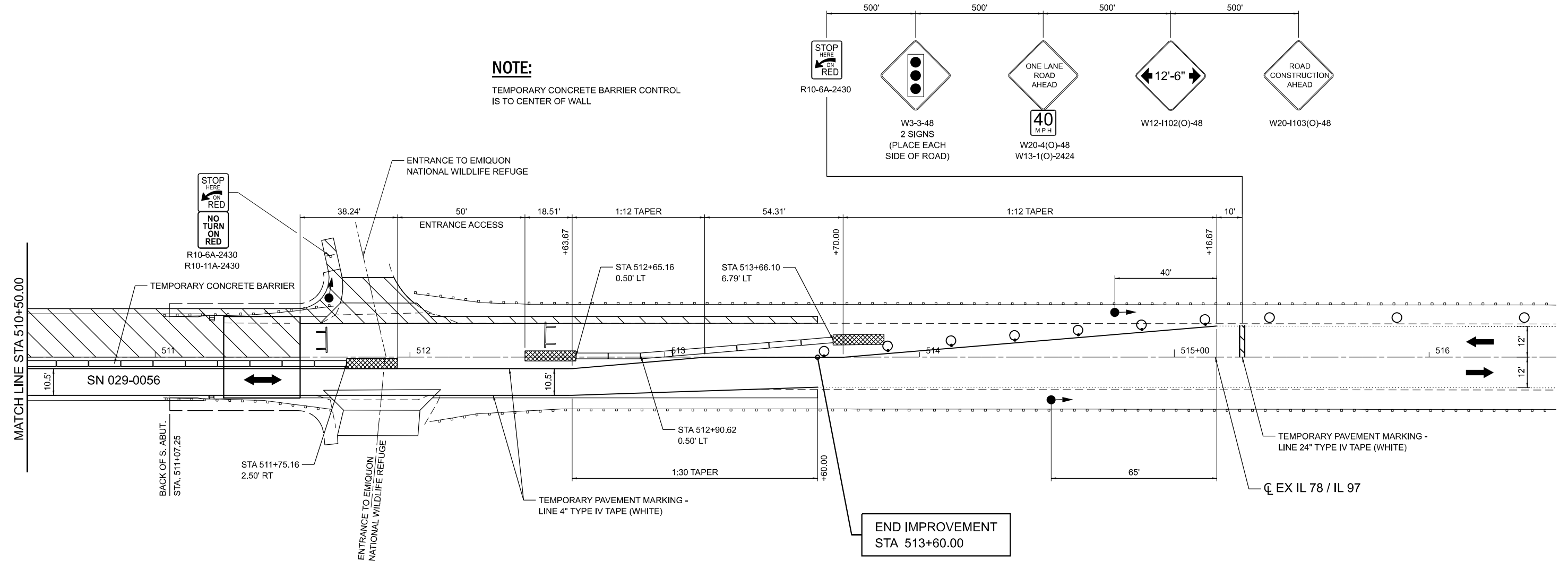

**LEGEND**

- WORK ZONE
- IMPACT ATTENUATOR
- TRAFFIC SIGN
- VERTICAL PANEL
- TEMPORARY CONCRETE BARRIER
- TYPE II BARRICADE OR DRUM WITH STEADY BURN LIGHT
- TYPE II BARRICADE WITH OR DRUM
- TYPE III BARRICADE
- DIRECTION OF TRAFFIC
- TEMPORARY TRAFFIC SIGNAL

MODEL: Unsaved (Plan - Sheet 1) (Sheet)  
 FILE NAME: S:\2023\211009\_PTB 2023-01-11\W20-2 Bridge Repair Plans 68H20CADD\CADD\_Sheet\0468H20-24-24-24.dwg



USER NAME = rgoertz	DESIGNED - RG	REVISED -
PLOT SCALE = 0.16666633' / in.	DRAWN - TO	REVISED -
PLOT DATE = 12/15/2023	CHECKED - SMK	REVISED -
	DATE -	REVISED -

**STATE OF ILLINOIS  
 DEPARTMENT OF TRANSPORTATION**

**MAINTENANCE OF TRAFFIC STAGE I PLANS  
 IL 78 / IL 97 (SN 029-0056)**

SCALE: 1" = 20'      SHEET 4 OF 7 SHEETS      STA. 510+50.00 TO STA. 513+60.00

F.A.P. RTE.	SECTION	COUNTY	TOTAL SHEETS	SHEET NO.
315/30	1139,138(BC;BC-1)BR,BR-1BRR	FULTON	119	45
ILLINOIS FED. AID PROJECT			CONTRACT NO. 68H20	

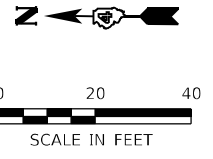

**NOTE:**

TEMPORARY CONCRETE BARRIER CONTROL IS TO CENTER OF WALL

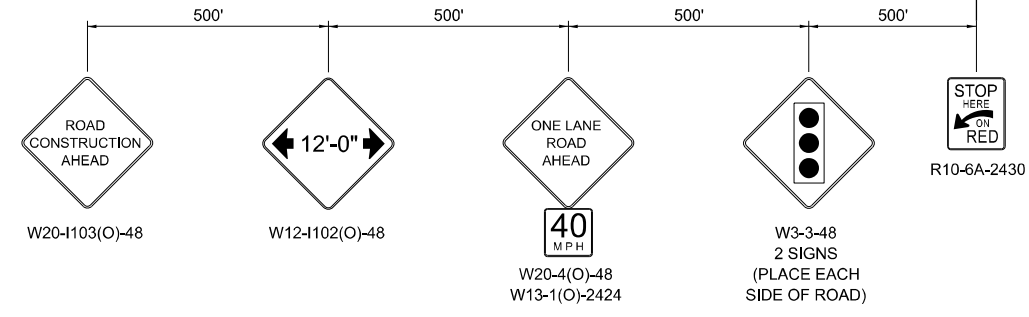
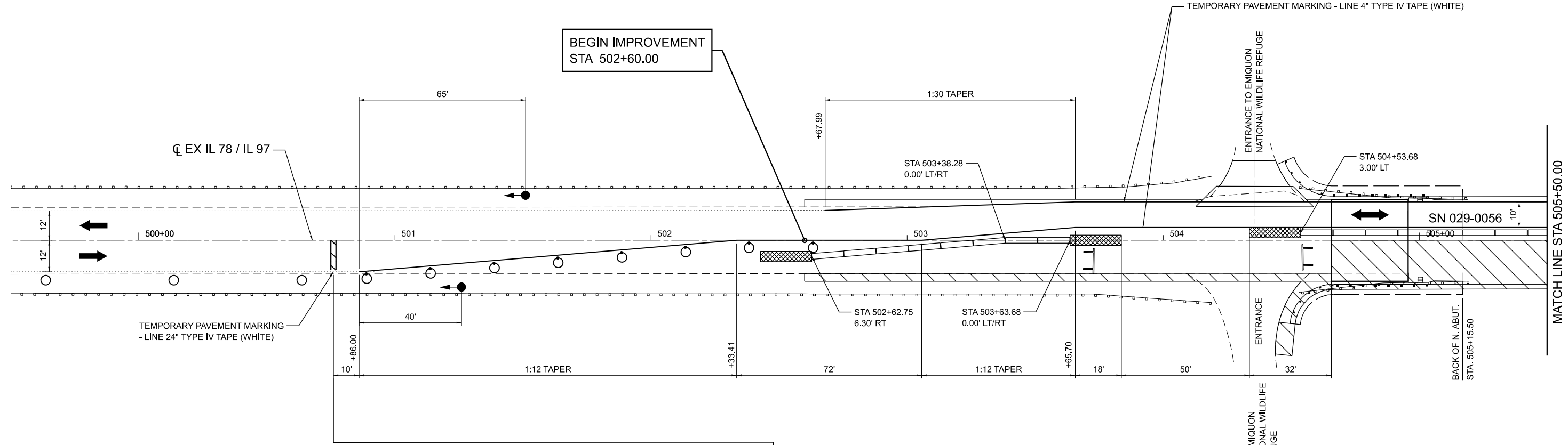

**LEGEND**

- WORK ZONE
- IMPACT ATTENUATOR
- TRAFFIC SIGN
- VERTICAL PANEL
- TEMPORARY CONCRETE BARRIER
- TYPE II BARRICADE OR DRUM WITH STEADY BURN LIGHT
- TYPE II BARRICADE WITH OR DRUM
- TYPE III BARRICADE
- DIRECTION OF TRAFFIC
- TEMPORARY TRAFFIC SIGNAL

MODEL: Unnamed (Plan) - File 3 (Sheet)  
 FILE NAME: S:\2023\21\LOG PTB 2023\04 - Hurst Roache - Various PH1 & IIVC2 Bridge Repair Plans 68H20CAD\CAD Sheets\68H20CAD\Drawing\_02.dwg



USER NAME = rgoertz	DESIGNED - RG	REVISED -
PLOT SCALE = 0.16666633' / in.	DRAWN - TO	REVISED -
PLOT DATE = 12/15/2023	CHECKED - SMK	REVISED -
	DATE -	REVISED -

**STATE OF ILLINOIS  
DEPARTMENT OF TRANSPORTATION**

**MAINTENANCE OF TRAFFIC STAGE II PLANS  
IL 78 / IL 97 (SN 029-0056)**

SCALE: 1" = 20'    SHEET 5 OF 7 SHEETS    STA. 502+60.00 TO STA. 505+50.00

F.A.P. RTE.	SECTION	COUNTY	TOTAL SHEETS	SHEET NO.
315/30	1139,138(BC;BC-1)BR, BR-1BR	FULTON	119	46
CONTRACT NO. 68H20			ILLINOIS FED. AID PROJECT	



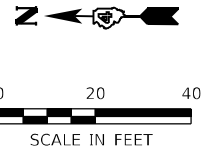

**NOTE:**  
 TEMPORARY CONCRETE BARRIER CONTROL  
 IS TO CENTER OF WALL

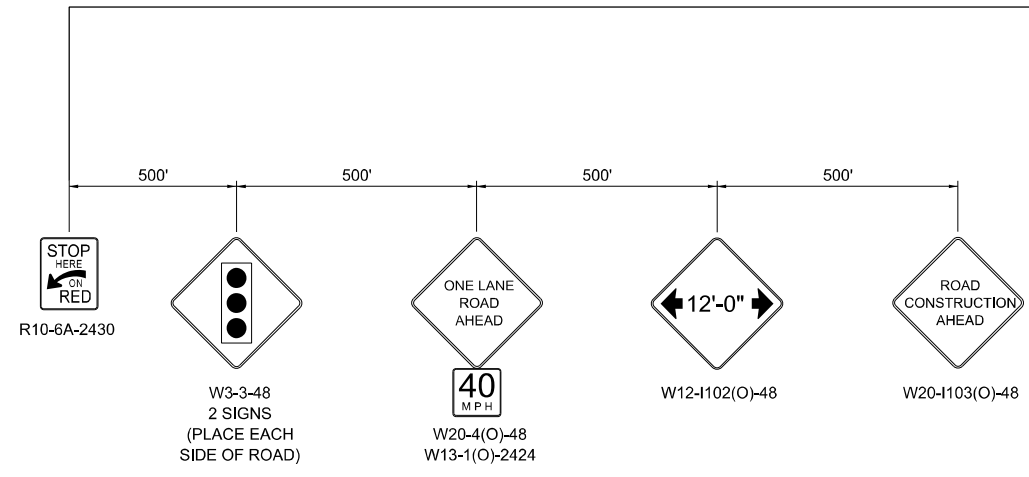
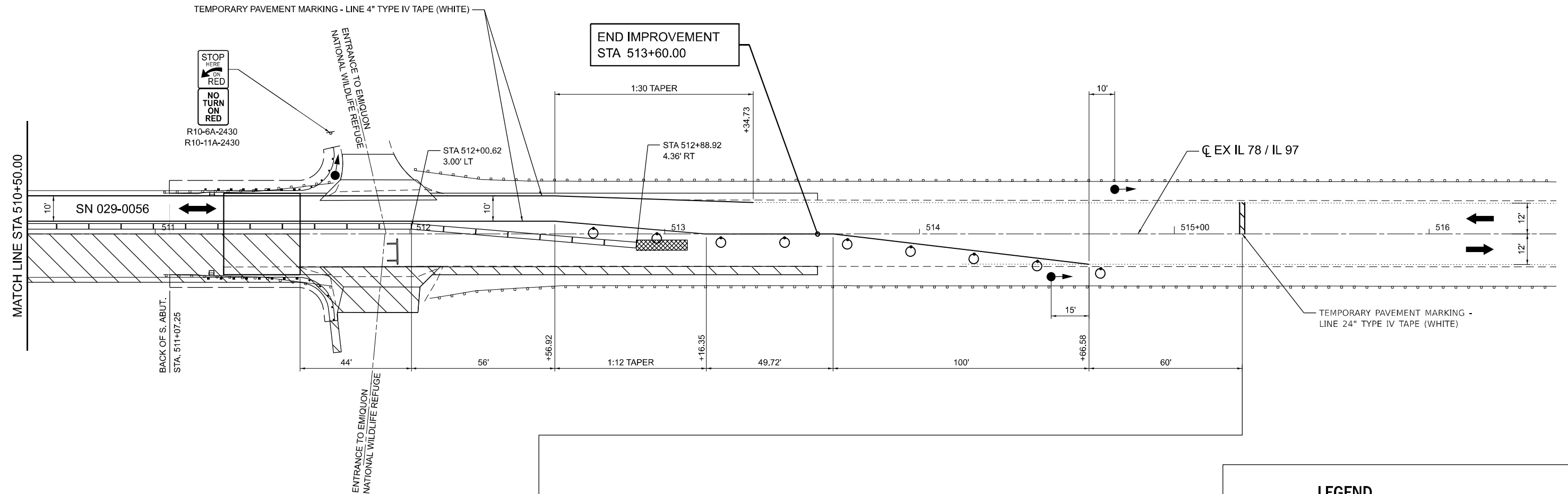

**LEGEND**

- WORK ZONE
- IMPACT ATTENUATOR
- TRAFFIC SIGN
- VERTICAL PANEL
- TEMPORARY CONCRETE BARRIER
- TYPE II BARRICADE OR DRUM WITH STEADY BURN LIGHT
- TYPE II BARRICADE WITH OR DRUM
- TYPE III BARRICADE
- DIRECTION OF TRAFFIC
- TEMPORARY TRAFFIC SIGNAL

MODEL: Unsaved (Plan) - File 1 (Sheet)  
 FILE NAME: S:\2023\211009\_PTB 20230.DWG - Hurst Roache - Various PH1 & IIVC2 Bridge Repair Plans 68H20CAD00\_CADD\_Sheet0468H20-4-Subarea\_02.dwg



USER NAME = rgoertz	DESIGNED - RG	REVISED -
PLOT SCALE = 0.16666633' / in.	DRAWN - TO	REVISED -
PLOT DATE = 12/15/2023	CHECKED - SMK	REVISED -
	DATE -	REVISED -

**STATE OF ILLINOIS  
 DEPARTMENT OF TRANSPORTATION**

**MAINTENANCE OF TRAFFIC STAGE II PLANS  
 IL 78 / IL 97 (SN 029-0056)**

SCALE: 1" = 20'    SHEET 7 OF 7 SHEETS    STA. 510+50.00 TO STA. 513+60.00

F.A.P. RTE.	SECTION	COUNTY	TOTAL SHEETS	SHEET NO.
315/30	1139,138(BC;BC-1)BR,BR-1(BRR)	FULTON	119	48
CONTRACT NO. 68H20			ILLINOIS FED. AID PROJECT	



MODEL: 029-021-029-0021 (Sheet)  
 FILE NAME: S:\2023\231006 PTB\_206-30 D4 - Hurst Rosche - Various PH I & II\WO-2 Bridge Repair Plans 68H20\CADD\CADD Sheets\68H20-sh1-typical.dgn

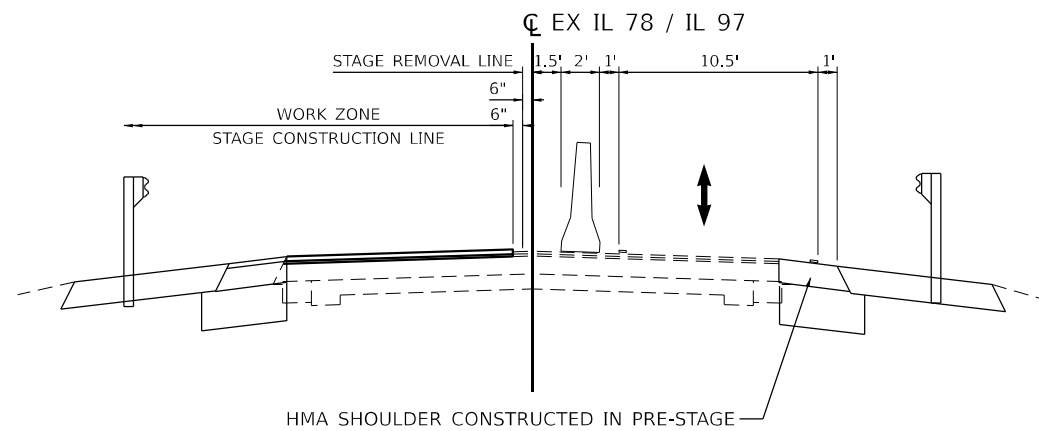

**STAGE I TYPICAL SECTION**

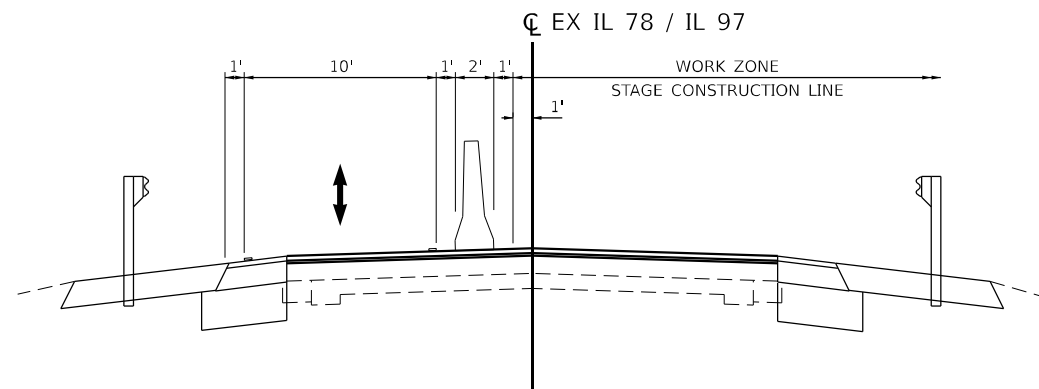

SN 029-0021  
 LOOKING SOUTH



**STAGE II TYPICAL SECTION**

SN 029-0021  
 LOOKING SOUTH

**LEGEND**

-  TEMPORARY CONCRETE BARRIER W/  
BARRIER WALL REFLECTORS, TYPE C
-  DIRECTION OF TRAFFIC

**STAGE CONSTRUCTION NOTES**

**PRE-STAGE TRAFFIC**

CLOSE SOUTHBOUND LANE AS REQUIRED USING HIGHWAY STANDARD 701326.

**PRE-STAGE CONSTRUCTION**

CONSTRUCT SOUTHBOUND SHOULDER AS DETAILED IN THE MAINTENANCE OF TRAFFIC STAGE I TYPICAL SECTION AND PLANS.

**STAGE I TRAFFIC**

CLOSE NORTHBOUND LANE TRANSITIONING NORTHBOUND AND SOUTHBOUND TRAFFIC INTO THE SOUTHBOUND LANE AND SHOULDER USING HIGHWAY STANDARD 701321 AND AS DETAILED IN THE MAINTENANCE OF TRAFFIC STAGE I TYPICAL SECTION AND PLANS.

**STAGE I CONSTRUCTION**

MILL PAVEMENT, BRIDGE DECK, APPROACH SLAB, AND SHOULDERS AS REQUIRED AND CONSTRUCT NORTHBOUND PAVEMENT, SHOULDERS, GUARDRAIL, AND STRUCTURE REPAIRS.

**STAGE II TRAFFIC**

CLOSE SOUTHBOUND LANE TRANSITIONING NORTHBOUND AND SOUTHBOUND TRAFFIC INTO THE NORTHBOUND LANE AND SHOULDER USING HIGHWAY STANDARD 701321 AND AS DETAILED IN THE MAINTENANCE OF TRAFFIC STAGE II TYPICAL SECTION PLANS.

**STAGE II CONSTRUCTION**

MILL PAVEMENT, BRIDGE DECK, APPROACH SLAB, AND SHOULDERS AS REQUIRED AND CONSTRUCT SOUTHBOUND PAVEMENT, SHOULDERS, GUARDRAIL, AND STRUCTURE REPAIRS.

**POST-STAGE TRAFFIC**

USE HIGHWAY STANDARDS 701201 AND 701311 FOR TRAFFIC CONTROL. PAY ITEMS AND SCHEDULES WITH QUANTITIES HAVE BEEN PROVIDED FOR TEMPORARY RAMPS, SHORT TERM PAVEMENT MARKINGS AND SHORT TERM PAVEMENT MARKING REMOVAL USED DURING POST-STAGE CONSTRUCTION SOUTH OF SN 029-0021.

**POST-STAGE CONSTRUCTION**

COMPLETE OVERLAY AND AGGREGATE WEDGE SHOULDER FOR PAVEMENT AREA SOUTH OF SN 029-0021. CONDUCT WORKSITE CLEANUP AND PLACE FINAL PAVEMENT MARKINGS.

**WIDTH RESTRICTION SIGNAGE**

SIX (6) SETS OF WIDTH RESTRICTION SIGNS WILL BE REQUIRED. PRECISE LOCATIONS WILL BE COORDINATED AT THE PRE-CONSTRUCTION MEETING.



USER NAME = rgoertz	DESIGNED - RG	REVISED -
	DRAWN - TO	REVISED -
PLOT SCALE = 0.16666833' / in.	CHECKED - SMK	REVISED -
PLOT DATE = 12/14/2023	DATE -	REVISED -

STATE OF ILLINOIS  
 DEPARTMENT OF TRANSPORTATION

MAINTENANCE OF TRAFFIC TYPICAL SECTIONS  
 IL 78 / IL 97 (SN 029-0021)

SCALE: NONE SHEET 1 OF 9 SHEETS STA. TO STA.

F.A.P. RTE.	SECTION	COUNTY	TOTAL SHEETS	SHEET NO.
315/30	1139,138(BC;BC-1)BR,BR-1BRR	FULTON	119	49
CONTRACT NO. 68H20				
ILLINOIS FED. AID PROJECT				

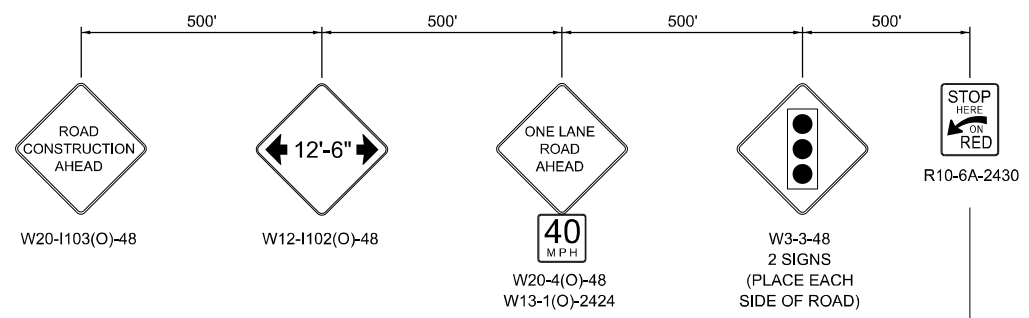
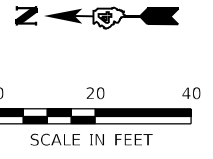

**NOTE:**  
TEMPORARY CONCRETE BARRIER CONTROL IS TO CENTER OF WALL

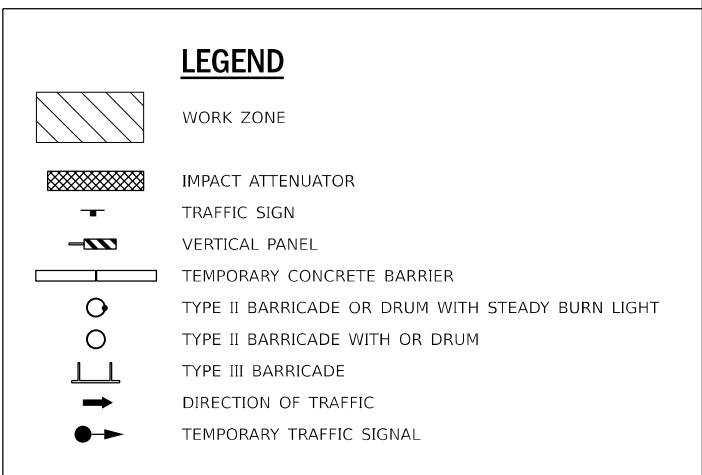
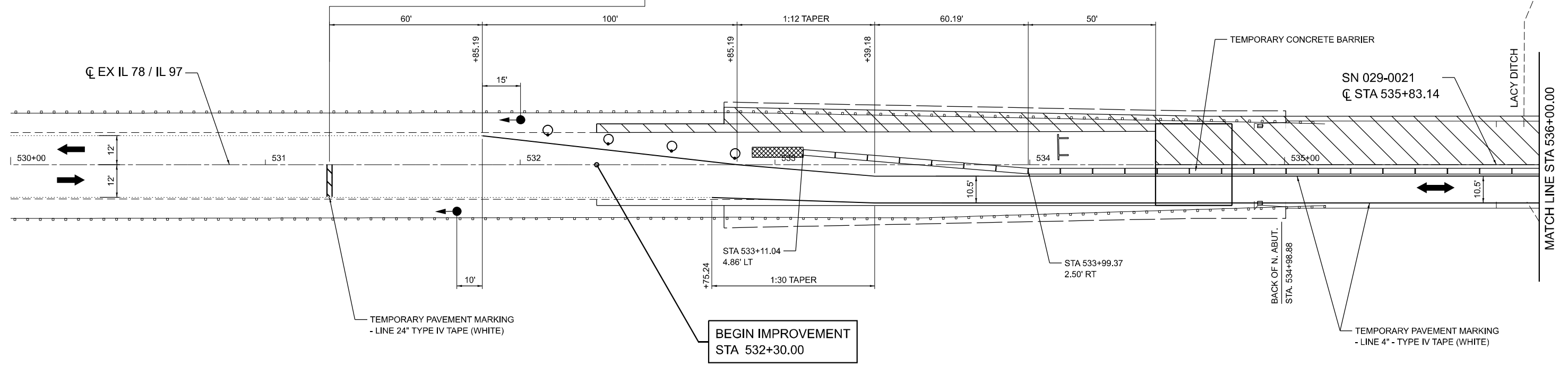

MODEL: Unnamed Plan - Plan 6 (Sheet)  
FILE NAME: S:\2023\2311\06 PTB\_206-30 D4 - Hurst Rosche - Various PH I & II\WO-2 Bridge Repair Plans 68H20\CADD\CADD Sheets\68H20-sheeting\_01.dgn



USER NAME = rgoertz	DESIGNED - RG	REVISED -
PLOT SCALE = 0.16666833' / in.	DRAWN - TO	REVISED -
PLOT DATE = 12/14/2023	CHECKED - SMK	REVISED -
	DATE -	REVISED -

**STATE OF ILLINOIS  
DEPARTMENT OF TRANSPORTATION**

**MAINTENANCE OF TRAFFIC STAGE I PLANS  
IL 78 / IL 97 (SN 029-0021)**

SCALE: 1" = 20'      SHEET 2 OF 9 SHEETS      STA. 532+30.00 TO STA. 536+00.00

F.A.P. RTE.	SECTION	COUNTY	TOTAL SHEETS	SHEET NO.
30/315	1139,138(BC;BC-1)BR,BR-1(BRR)	FULTON	119	50
CONTRACT NO. 68H20				
ILLINOIS FED. AID PROJECT				

MODEL: Unnamed Plan - Plan 7 (Sheet)  
 FILE NAME: S:\2023\231106 PTB 206-30 D4 - Hurst Rosche - Various PH I & II\WO-2 Bridge Repair Plans 68H20\CADD\CADD Sheets\468H20-sheeting\_01.dgn

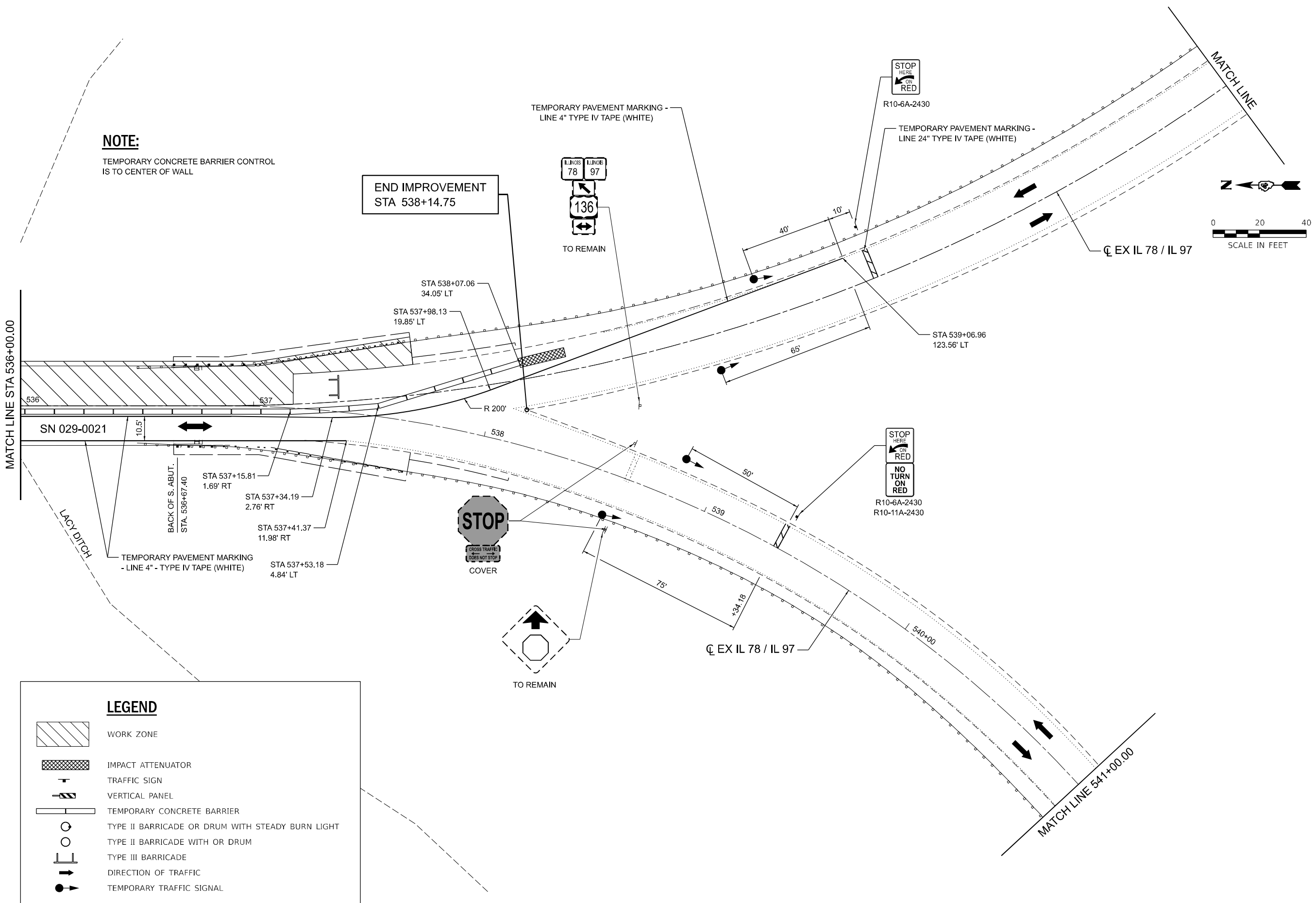

**NOTE:**  
 TEMPORARY CONCRETE BARRIER CONTROL IS TO CENTER OF WALL

**END IMPROVEMENT**  
 STA 538+14.75

MATCH LINE STA 536+00.00

Q EX IL 78 / IL 97

**LEGEND**

- WORK ZONE
- IMPACT ATTENUATOR
- VERTICAL PANEL
- TEMPORARY CONCRETE BARRIER
- TYPE II BARRICADE OR DRUM WITH STEADY BURN LIGHT
- TYPE II BARRICADE WITH OR DRUM
- TYPE III BARRICADE
- DIRECTION OF TRAFFIC
- TEMPORARY TRAFFIC SIGNAL



USER NAME = rgoertz	DESIGNED - RG	REVISED -
PLOT SCALE = 0.16666833" / in.	DRAWN - TO	REVISED -
PLOT DATE = 12/14/2023	CHECKED - SMK	REVISED -
	DATE -	REVISED -

**STATE OF ILLINOIS**  
**DEPARTMENT OF TRANSPORTATION**

**MAINTENANCE OF TRAFFIC STAGE I PLANS**  
**IL 78 / 97 (SN 029-0021)**

SCALE: 1" = 20'    SHEET 3 OF 9 SHEETS    STA. 536+00.00 TO STA. 537+50.00

F.A.P. RTE.	SECTION	COUNTY	TOTAL SHEETS	SHEET NO.
315/30	1139,138(BC,BC-1)BR,BR-1)BRR	FULTON	119	51
CONTRACT NO. 68H20				
ILLINOIS FED. AID PROJECT				

MODEL: Unnamed Plan - Plan 8 (Sheet)  
 FILE NAME: S:\2023\231006 PTB 206-30 D4 - Hurst Rosche - Various PH I & II\WO-2 Bridge Repair Plans 68H20\CADD\CADD Sheets\I468H20-sheeting\_01.dgn

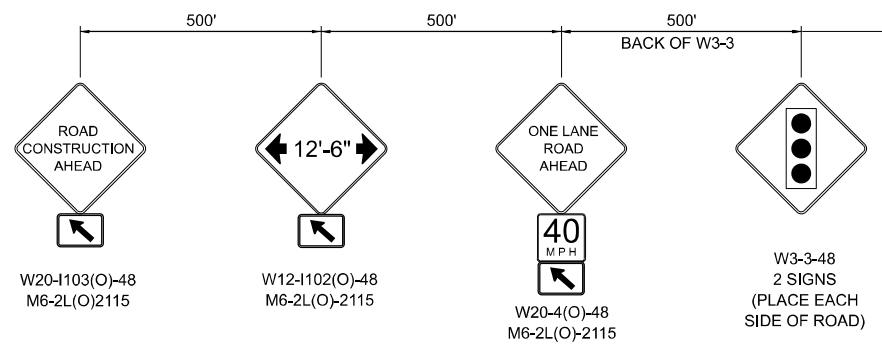
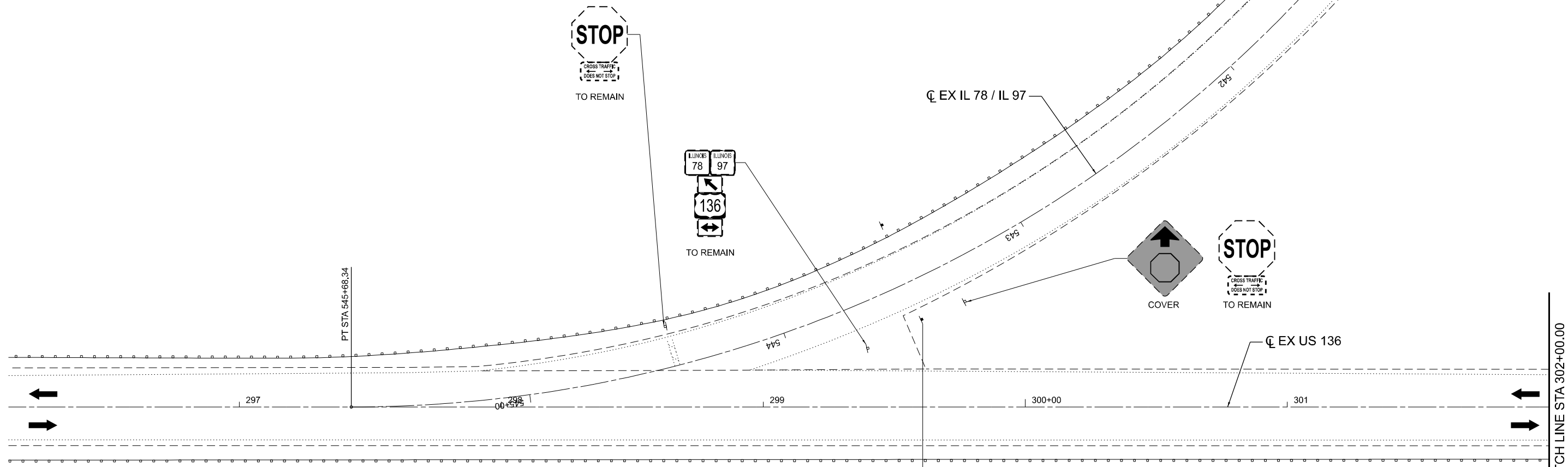
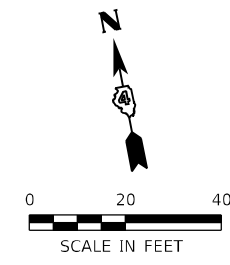

LEGEND	
	WORK ZONE
	IMPACT ATTENUATOR
	TRAFFIC SIGN
	VERTICAL PANEL
	TEMPORARY CONCRETE BARRIER
	TYPE II BARRICADE OR DRUM WITH STEADY BURN LIGHT
	TYPE II BARRICADE WITH OR DRUM
	TYPE III BARRICADE
	DIRECTION OF TRAFFIC
	TEMPORARY TRAFFIC SIGNAL



USER NAME = rgoertz	DESIGNED - RG	REVISED -
PLOT SCALE = 0.16666833' / in.	DRAWN - TO	REVISED -
PLOT DATE = 12/14/2023	CHECKED - SMK	REVISED -
	DATE -	REVISED -

**STATE OF ILLINOIS  
 DEPARTMENT OF TRANSPORTATION**

**MAINTENANCE OF TRAFFIC STAGE I PLANS  
 IL 78 / IL 97 (SN 029-0021)**

SCALE: 1" = 20'	SHEET 4	OF 9 SHEETS	STA. 541+00.00	TO STA. 545+68.34
-----------------	---------	-------------	----------------	-------------------

F.A.P. RTE.	SECTION	COUNTY	TOTAL SHEETS	SHEET NO.
315/30	1139,138(BC;BC-1)BR,BR-1)BRR	FULTON	119	52
CONTRACT NO. 68H20				
ILLINOIS FED. AID PROJECT				

MODEL: Unnamed Plan - Plan 9 (Sheet)  
 FILE NAME: S:\2023\2311\006 PTB\_206-30 D4 - Hurst Rosche - Various PH I & II\WO-2 Bridge Repair Plans 68H20\CADD\CADD Sheets\1468H20-shtstaging\_01.dgn

MATCH LINE STA 302+00.00

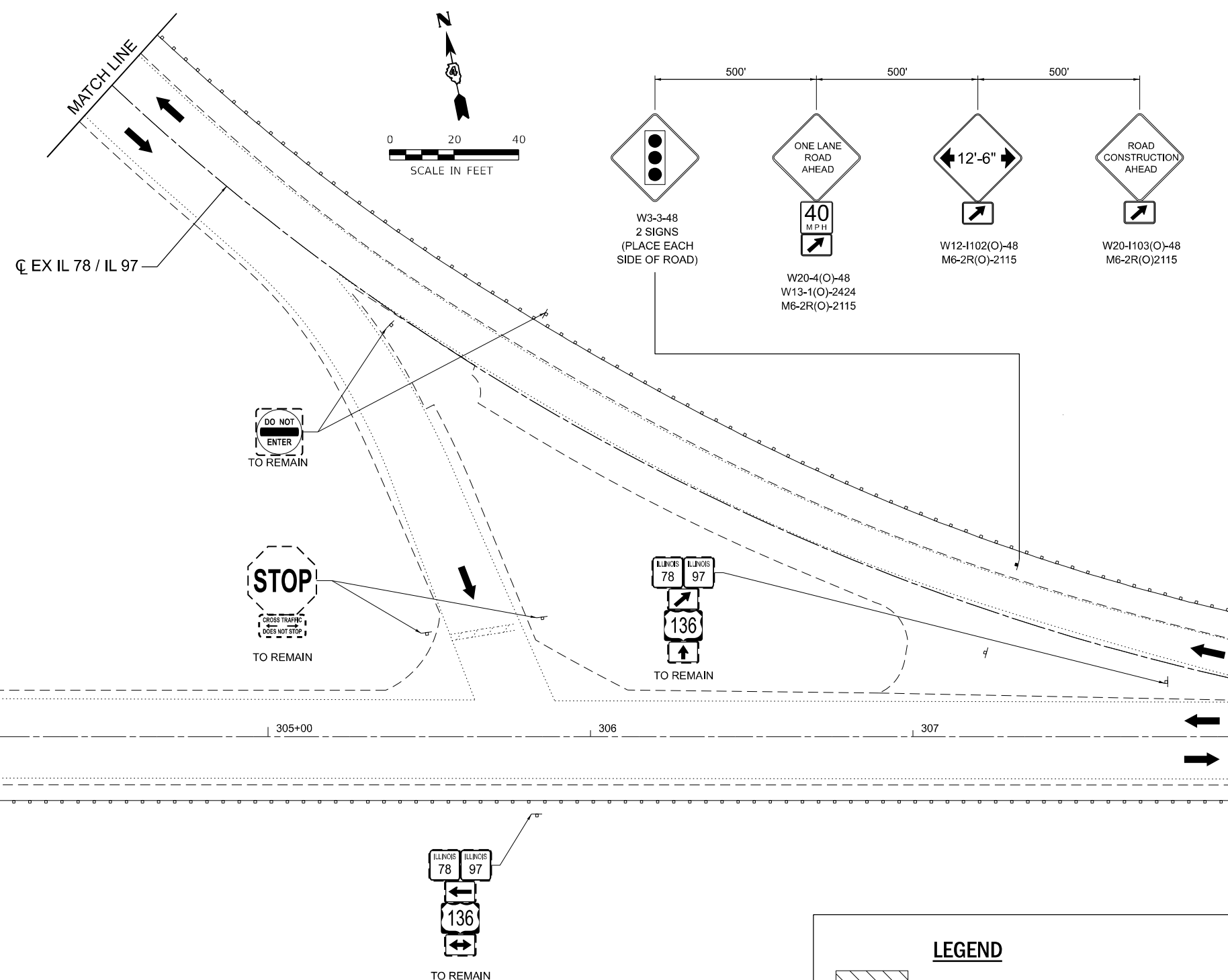

LEGEND	
	WORK ZONE
	IMPACT ATTENUATOR
	TRAFFIC SIGN
	VERTICAL PANEL
	TEMPORARY CONCRETE BARRIER
	TYPE II BARRICADE OR DRUM WITH STEADY BURN LIGHT
	TYPE II BARRICADE WITH OR DRUM
	TYPE III BARRICADE
	DIRECTION OF TRAFFIC
	TEMPORARY TRAFFIC SIGNAL



USER NAME = rgoertz	DESIGNED - RG	REVISED -
DRAWN - TO	REVISIONS -	
PLOT SCALE = 0.166666833' / in.	CHECKED - SMK	REVISED -
PLOT DATE = 12/14/2023	DATE -	REVISED -

STATE OF ILLINOIS  
 DEPARTMENT OF TRANSPORTATION

MAINTENANCE OF TRAFFIC STAGE I PLANS  
 IL 78 / IL 97 (SN 029-0021)

F.A.P. RTE.	SECTION	COUNTY	TOTAL SHEETS	SHEET NO.
315/30	1139,138(BC;BC-1)BR,BR-1)BRR	FULTON	119	53
CONTRACT NO. 68H20				
ILLINOIS FED. AID PROJECT				

SCALE: 1" = 20' SHEET 5 OF 9 SHEETS STA. 302+00.00 TO STA. 308+00.00

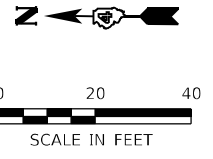

**NOTE:**

TEMPORARY CONCRETE BARRIER CONTROL IS TO CENTER OF WALL

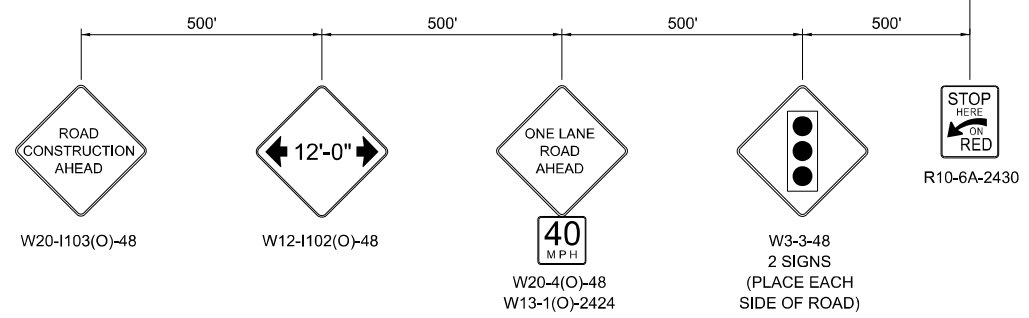
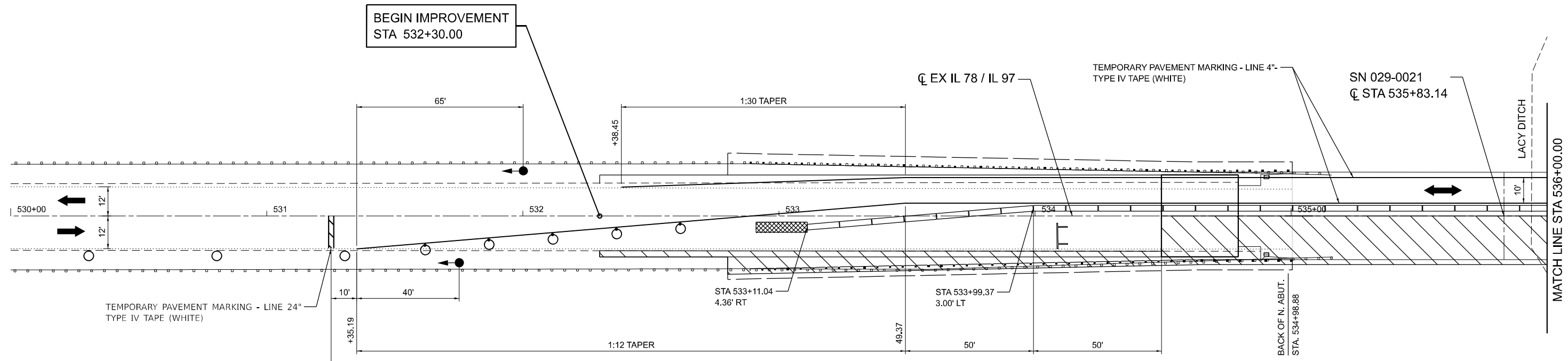

**LEGEND**

- WORK ZONE
- IMPACT ATTENUATOR
- TRAFFIC SIGN
- VERTICAL PANEL
- TEMPORARY CONCRETE BARRIER
- TYPE II BARRICADE OR DRUM WITH STEADY BURN LIGHT
- TYPE II BARRICADE WITH OR DRUM
- TYPE III BARRICADE
- DIRECTION OF TRAFFIC
- TEMPORARY TRAFFIC SIGNAL

MODEL: Unnamed Plan - Plan 6 (Sheet)  
 FILE NAME: S:\2023\2311006 PTB 206-30 D4 - Hurst Rosche - Various PH I & II\WO-2 Bridge Repair Plans 68H20\CADD\CADD Sheets\68H20-sheet6ing\_02.dgn



USER NAME = rgoertz	DESIGNED - RG	REVISED -
DRAWN - TO	REVISOR -	
PLOT SCALE = 0.16666833' / in.	CHECKED - SMK	REVISED -
PLOT DATE = 12/14/2023	DATE -	REVISED -

**STATE OF ILLINOIS  
DEPARTMENT OF TRANSPORTATION**

**MAINTENANCE OF TRAFFIC STAGE II PLANS  
IL 78 / IL 97 (SN 029-0021)**

SCALE: 1" = 20'      SHEET 6 OF 9 SHEETS      STA. 532+30.00 TO STA. 536+00.00

F.A.P. RTE.	SECTION	COUNTY	TOTAL SHEETS	SHEET NO.
315/30	1139,138(BC;BC-1)BR,BR-1)BRR	FULTON	119	54
CONTRACT NO. 68H20				
ILLINOIS FED. AID PROJECT				

MODEL: Unnamed Plan - Plan 7 (Sheet)  
 FILE NAME: S:\2023\231006 PTB 206-30 D4 - Hurst Rosche - Various PH I & IIWO-2 Bridge Repair Plans 68H20\CADD\CADD Sheets\468H20-sheeting\_02.dgn

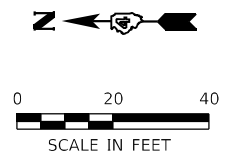
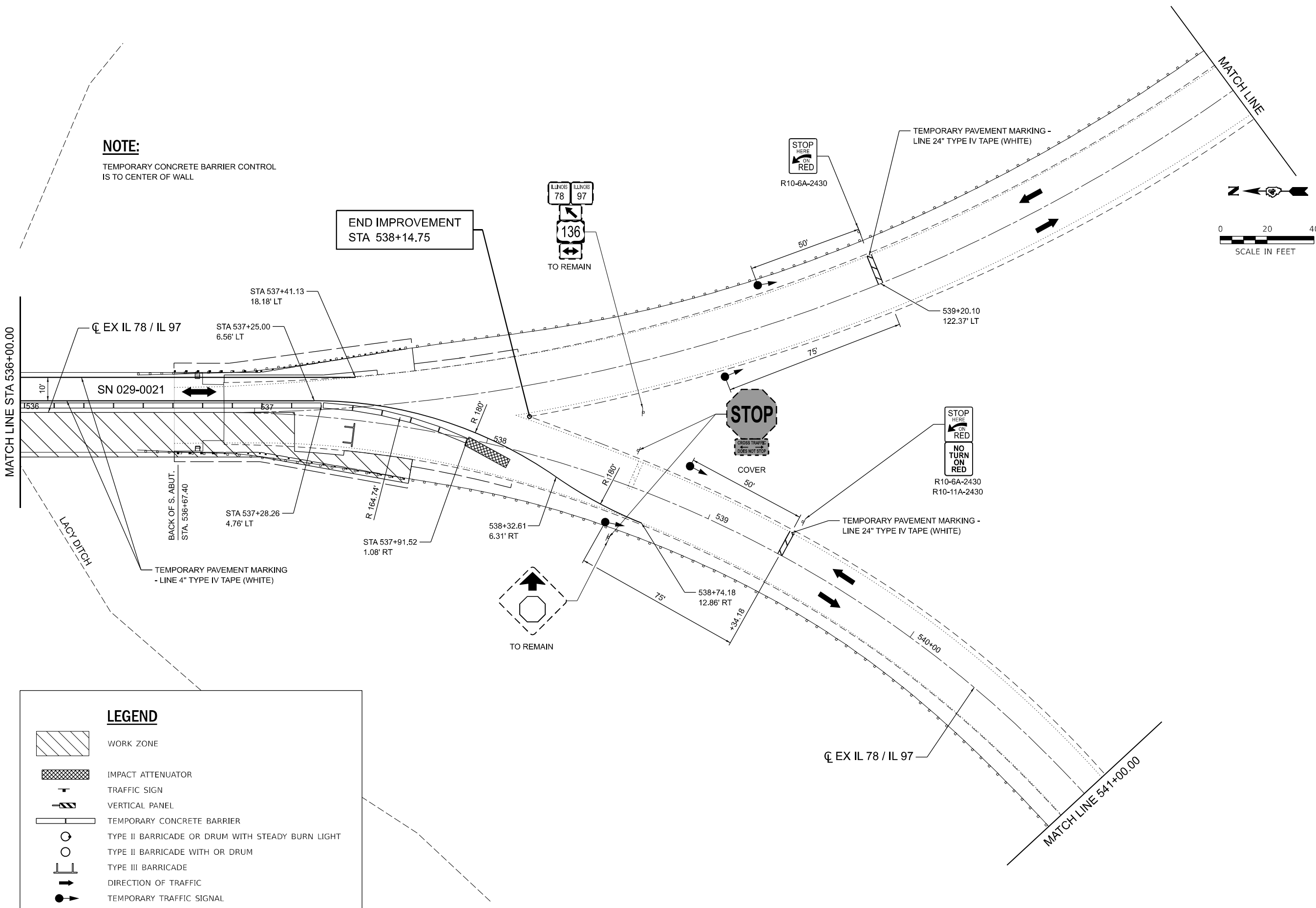

USER NAME = rgoertz	DESIGNED - RG	REVISED -
PLOT SCALE = 0.16666833' / in.	DRAWN - TO	REVISED -
PLOT DATE = 12/14/2023	CHECKED - SMK	REVISED -
	DATE -	REVISED -

**STATE OF ILLINOIS**  
**DEPARTMENT OF TRANSPORTATION**

**MAINTENANCE OF TRAFFIC STAGE II PLANS**  
**IL 78 / IL 97 (SN 029-0021)**

SCALE: 1" = 20' SHEET 7 OF 9 SHEETS STA. 536+00.00 TO STA. 541+00.00

F.A.P. RTE.	SECTION	COUNTY	TOTAL SHEETS	SHEET NO.
315/30	1139,138(BC,BC-1)BR,BR-1BRR	FULTON	119	55
CONTRACT NO. 68H20				
ILLINOIS FED. AID PROJECT				

MODEL: Unnamed Plan - Plan 8 (Sheet)  
 FILE NAME: S:\2023\2311\06 PTB 206-30 D4 - Hurst Rosche - Various PH I & II\WO-2 Bridge Repair Plans 68H20\CADD\CADD Sheets\I468H20-sheet8.dgn

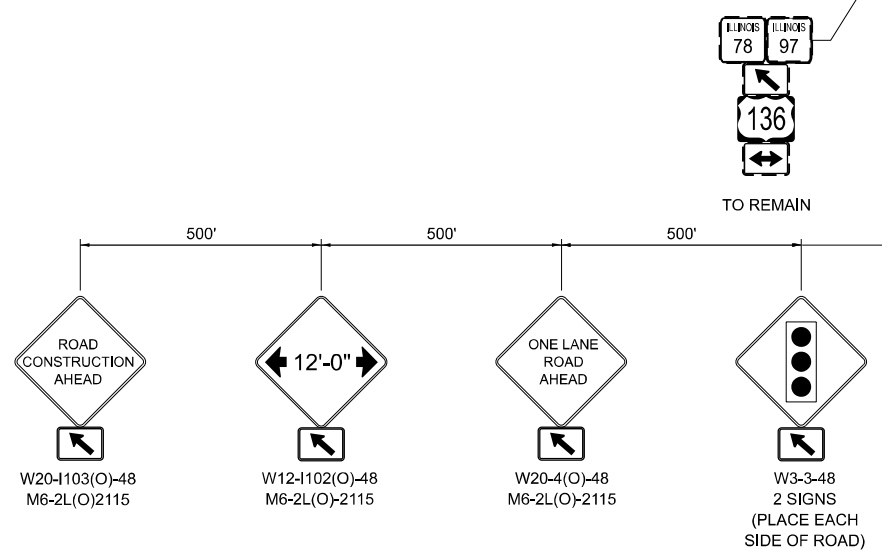
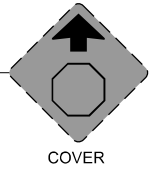
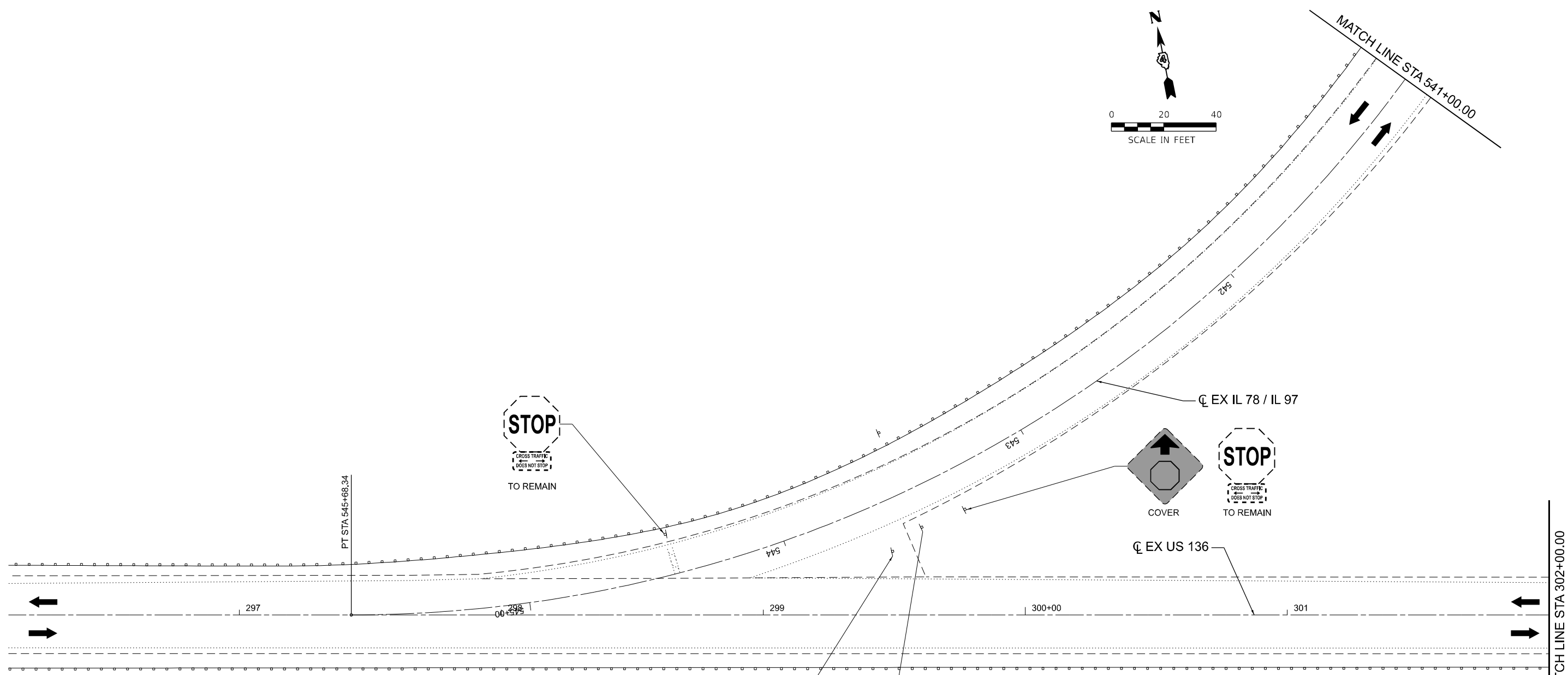
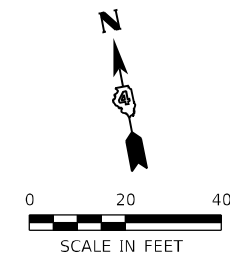

LEGEND	
	WORK ZONE
	IMPACT ATTENUATOR
	TRAFFIC SIGN
	VERTICAL PANEL
	TEMPORARY CONCRETE BARRIER
	TYPE II BARRICADE OR DRUM WITH STEADY BURN LIGHT
	TYPE II BARRICADE WITH OR DRUM
	TYPE III BARRICADE
	DIRECTION OF TRAFFIC
	TEMPORARY TRAFFIC SIGNAL



USER NAME = rgoertz	DESIGNED - RG	REVISED -
PLOT SCALE = 0.16666833' / in.	DRAWN - TO	REVISED -
PLOT DATE = 12/14/2023	CHECKED - SMK	REVISED -
	DATE -	REVISED -

STATE OF ILLINOIS  
 DEPARTMENT OF TRANSPORTATION

MAINTENANCE OF TRAFFIC STAGE II PLANS  
 IL 78 / IL 97 (SN (029-0021))

SCALE: 1" = 20'	SHEET 8	OF 9	SHEETS	STA. 541+00.00	TO STA. 545+68.34
-----------------	---------	------	--------	----------------	-------------------

F.A.P. RTE.	SECTION	COUNTY	TOTAL SHEETS	SHEET NO.
315/30	1139,138(BC;BC-1)BR,BR-1)BRR	FULTON	119	56
CONTRACT NO. 68H20			ILLINOIS FED. AID PROJECT	



MODEL: Unnamed Plan - Plan 9 (Sheet)  
 FILE NAME: S:\2023\2311\06 PTB\_206-30 D4 - Hurst Rosche - Various PH I & II\WO-2 Bridge Repair Plans 68H20\CADD\CADD Sheets\1468H20-sheet9a.dgn

MATCH LINE STA 302+00.00

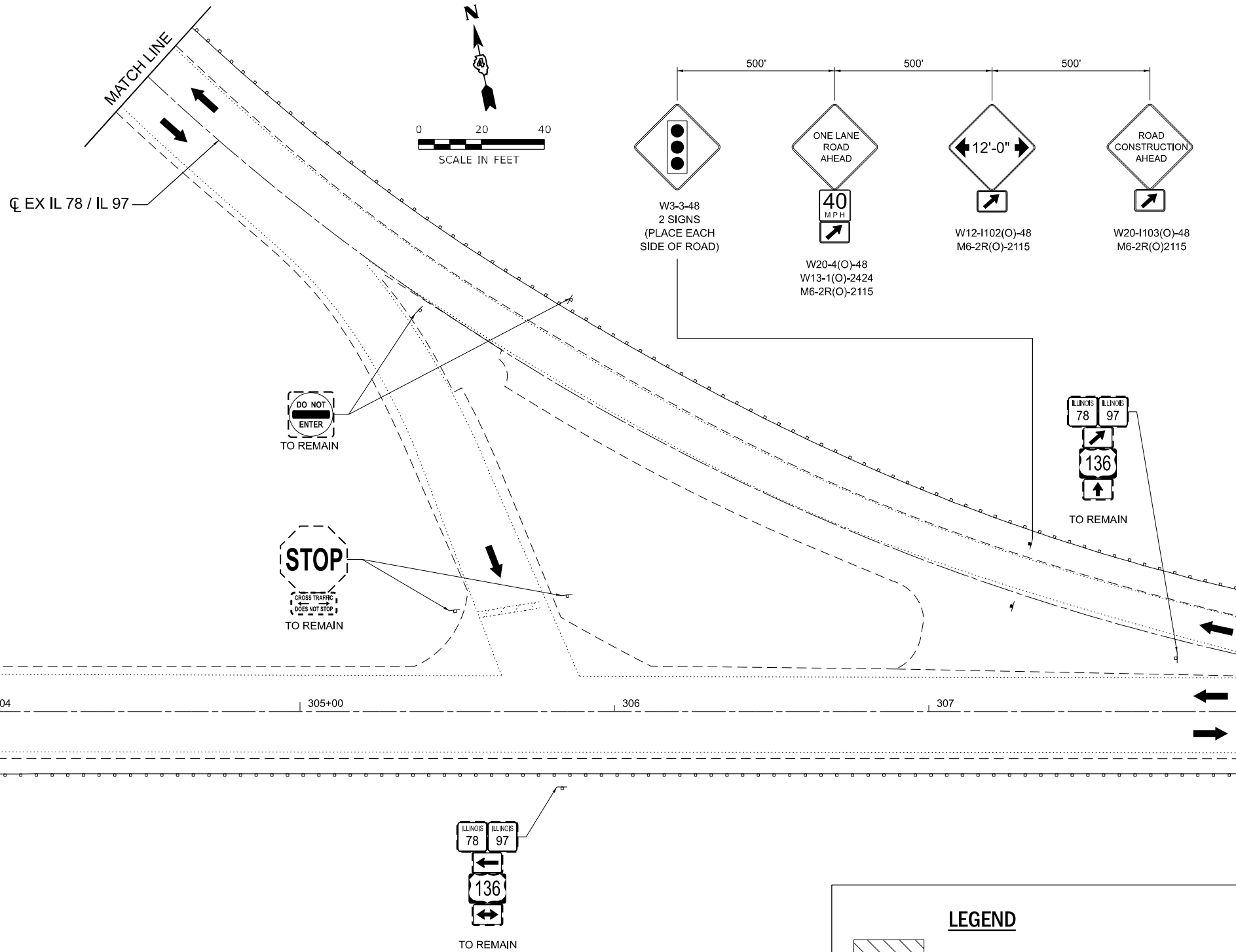

LEGEND	
	WORK ZONE
	IMPACT ATTENUATOR
	TRAFFIC SIGN
	VERTICAL PANEL
	TEMPORARY CONCRETE BARRIER
	TYPE II BARRICADE OR DRUM WITH STEADY BURN LIGHT
	TYPE II BARRICADE WITH OR DRUM
	TYPE III BARRICADE
	DIRECTION OF TRAFFIC
	TEMPORARY TRAFFIC SIGNAL



USER NAME = rgoertz	DESIGNED - RG	REVISED -
DRAWN - TO	CHECKED - SMK	REVISED -
PLOT SCALE = 0.16666833' / in.	DATE -	REVISED -
PLOT DATE = 12/14/2023		

STATE OF ILLINOIS  
 DEPARTMENT OF TRANSPORTATION

MAINTENANCE OF TRAFFIC STAGE II PLANS  
 IL 78 / IL 97 (SN 029-0021)

SCALE: 1" = 20' SHEET 9 OF 9 SHEETS STA. 302+00.00 TO STA. 308+00.00

F.A.P. RTE.	SECTION	COUNTY	TOTAL SHEETS	SHEET NO.
315/30	1139,138(BC;BC-1)BR,BR-1)BRR	FULTON	119	57
CONTRACT NO. 68H20				
ILLINOIS FED. AID PROJECT				

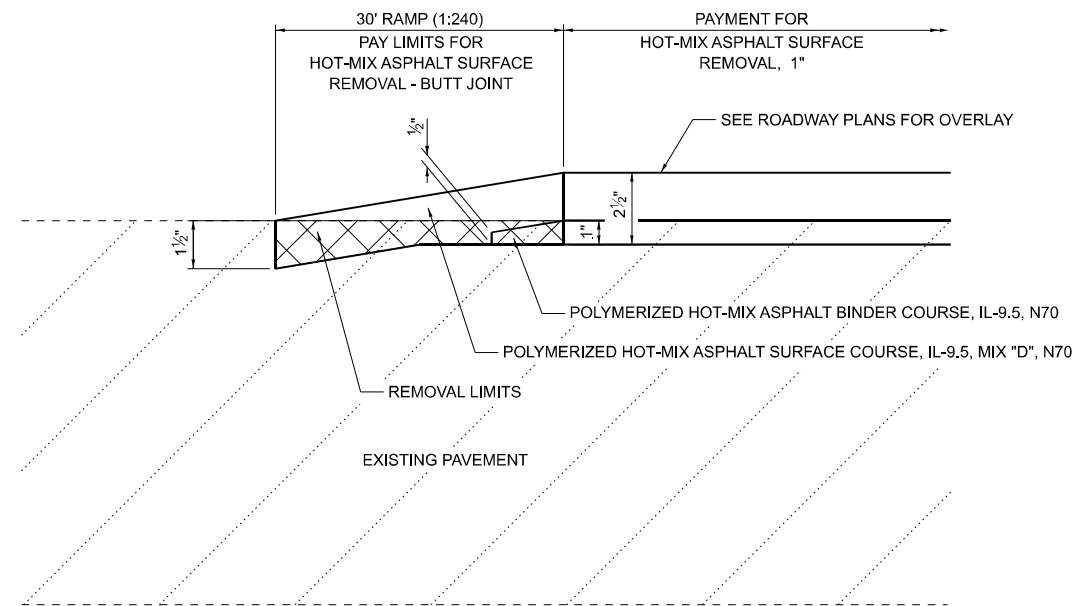
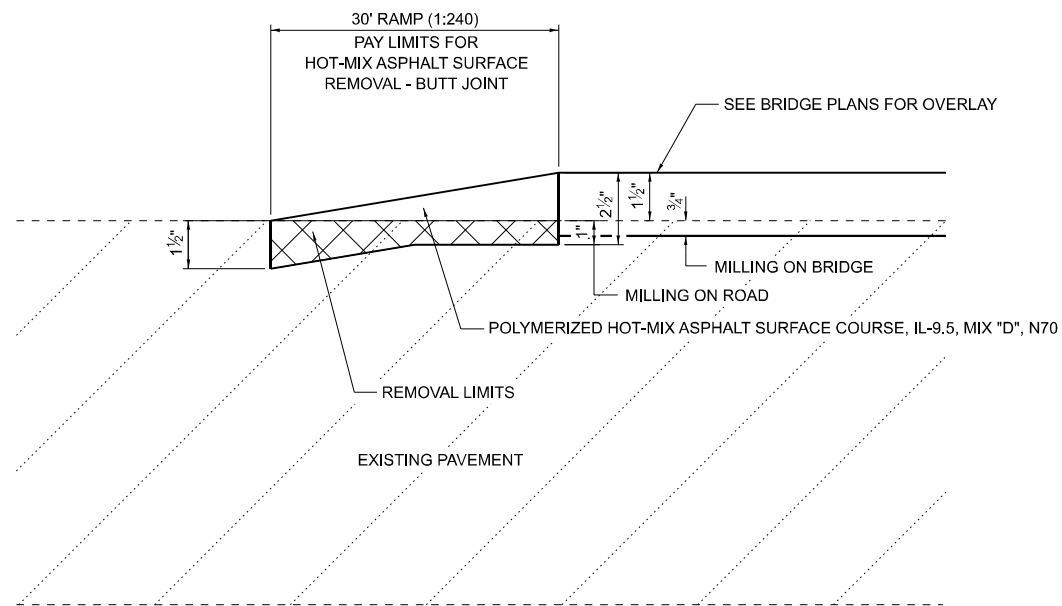

**BUTT JOINT DETAIL**

**SN 029-0012 (US 136)**  
 STA 323+28.10 TO STA 323+58.10  
 STA 326+51.12 TO STA 326+81.12

**SN 029-0055 (IL 78 / IL 97)**  
 STA 490+55.38 TO STA 490+85.38  
 STA 495+14.77 TO STA 495+44.77

**SN 029-0056 (IL 78 / IL 97)**  
 STA 504+65.70 TO STA 504+95.70  
 STA 511+26.92 TO STA 511+56.92

**SN 029-0021 (IL 78 / IL 97)**  
 STA 534+49.37 TO STA 534+79.37

**BUTT JOINT DETAIL**

**SN 029-0021 (IL 78 / IL 97)**  
 STA 537+84.75 TO STA 538+14.75

MODEL: Unnamed (1) - File 1 (Sheet)  
 FILE NAME: S:\2023\21\008\PTB 20230.DWG - Hurst Roache - Various PH1 & IJWC2 Bridge Repair Plans 68H20\CAD\CADD\_Sheet\0468H20-but joint detail.dgn



USER NAME = rgoertz	DESIGNED - RG	REVISED -
PLOT SCALE = 0.16666633' / in.	DRAWN - TO	REVISED -
PLOT DATE = 12/15/2023	CHECKED - SMK	REVISED -
	DATE -	REVISED -

**STATE OF ILLINOIS  
 DEPARTMENT OF TRANSPORTATION**

**BUTT JOINT DETAILS  
 US 30 / IL 78 / IL 97**

SCALE: NONE SHEET 1 OF 1 SHEETS STA. TO STA.

F.A.P. RTE.	SECTION	COUNTY	TOTAL SHEETS	SHEET NO.
315/30	1139,138(BC;BC-1)BR,BR-1 BRR	FULTON	119	58
CONTRACT NO. 68H20				
ILLINOIS FED. AID PROJECT				

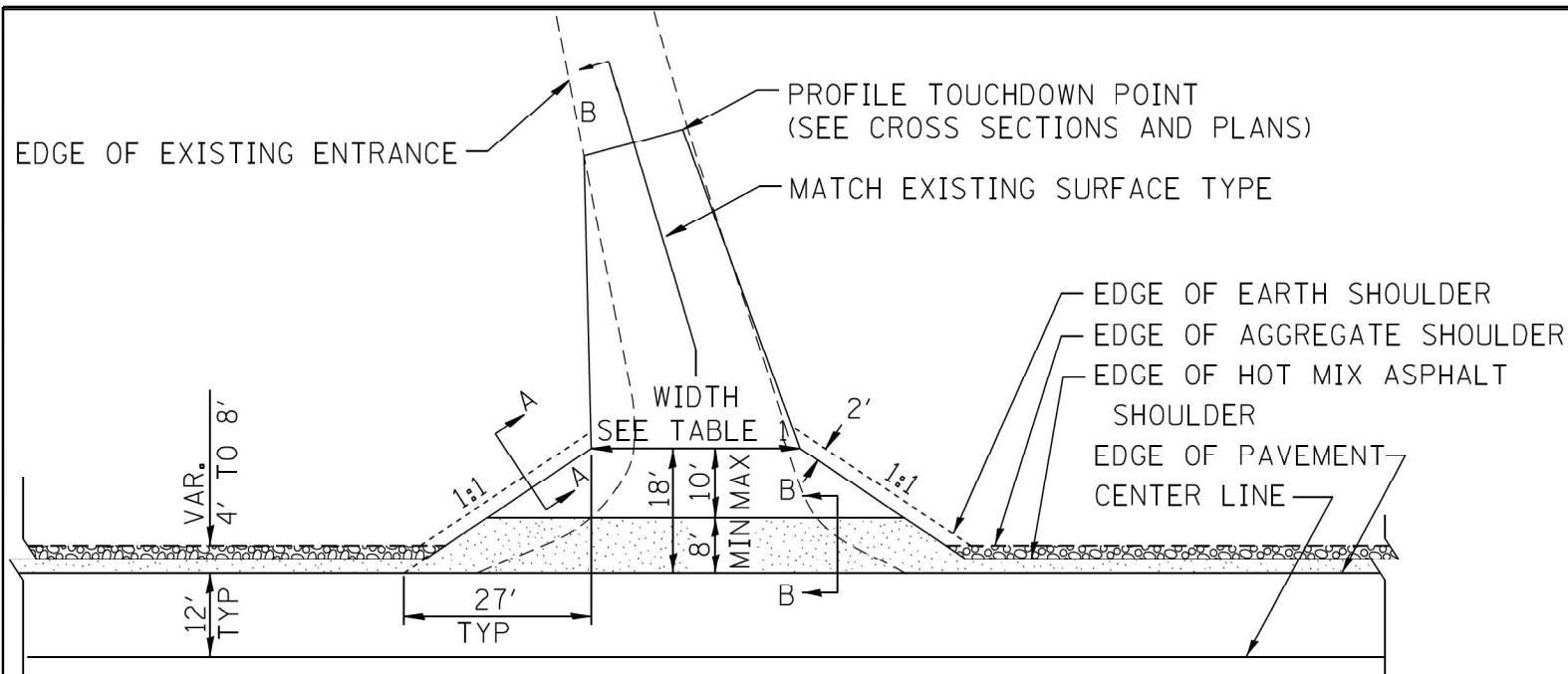
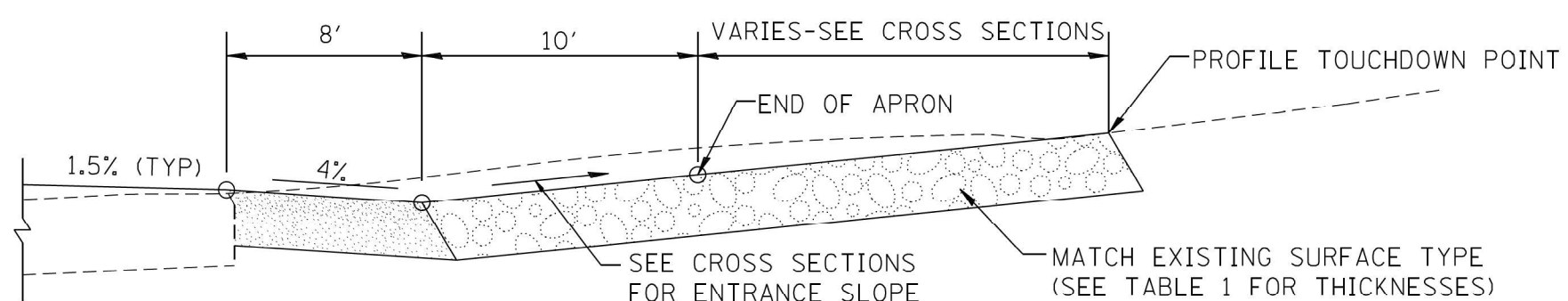

TABLE 1					
RURAL ENTRANCE DESIGN					
ELEMENT	NON-COMMERCIAL		NON-COMMERCIAL W/ LARGE FARM EQUIPMENT	COMMERCIAL	
				1-WAY OPERATION	2-WAY OPERATION
WIDTH (W)	12'(3.6m) Min.	24'(7.2m) Max.	20' (6.1m)Min.	14'(4.3m) Min.	24'(7.2m) Max.
FLARE			30'(9.0m)Max.	24'(7.2m) Min.	35'(10.7m) Max.
MAX. GRADE (G)	12%		12%	10%	
SURFACE TYPE					
INCIDENTAL HOT MIX ASPHALT SURFACING	6"		—	8"	
AGGREGATE SURFACE COURSE	6"		8"	—	
PCC DRIVEWAY PAVEMENT	6"		—	7"	

HOT MIX ASPHALT SHOULDER, 8"  
 AGGREGATE SHOULDER, TYPE B, 6"

**PLAN**  
COMMERCIAL / FARM-RELATED ENTRANCE



**SECTION B-B**  
RECONSTRUCTED RURAL ENTRANCE  
(EXISTING ENTRANCE HIGHER THAN APRON)

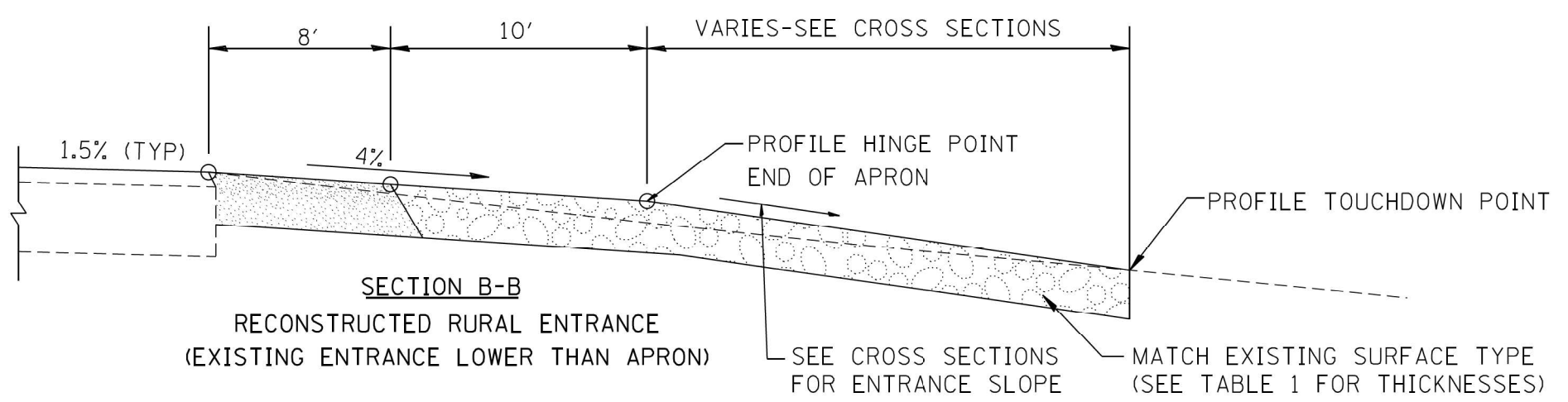

**SECTION B-B**  
RECONSTRUCTED RURAL ENTRANCE  
(EXISTING ENTRANCE LOWER THAN APRON)

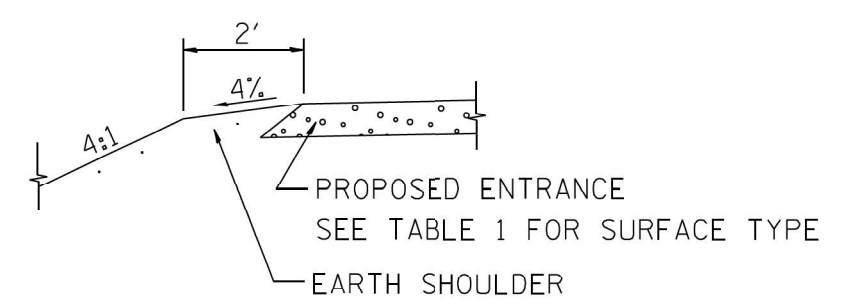

**SECTION A-A**  
SHOULDER TREATMENT FOR RURAL ENTRANCES

GENERAL NOTES

- ENTRANCES SHALL SLOPE AWAY FROM THE PAVEMENT AT A RATE EQUAL TO THE SHOULDER SLOPE FOR A MINIMUM DISTANCE OF 8'.
- A MINIMUM 8' PAVED SHOULDER SHALL BE CONSTRUCTED BETWEEN LOCATIONS WHERE THE RURAL ENTRANCE IS LESS THAN 50' FROM AN ADJACENT SIDEROAD, ENTRANCE OR MAILBOX TURNOUT.
- A TAPER RATE OF 5:1 IS DESIRABLE WHEN TRANSITING FROM THE RURAL ENTRANCE WIDTH SHOWN IN TABLE 1, TO THE EXISTING ENTRANCE WIDTH.

All dimensions are in inches (millimeters) unless otherwise noted.

01-01-97	RENUM. C-103.06, NEW REVISION BOX	T.P.	10-16-06	REVISED TO 2007 SPEC.	M.A.
07-01-97	REVISE DESIGNER NOTES	J.A.	9-15-15	UPDATED TABLE 1	R.D.
01-17-03	ADJUST DESIGN, CHANGE ENTRANCE	JATR	2-29-16	MINOR CORRECTIONS	R.D.
09-15-05	RADIUS FOR FLARE	M.M.A.	5-9-17	CHANGED TAPER RATE	R.D.

**STATE OF ILLINOIS**  
**DEPARTMENT OF TRANSPORTATION**

NOT TO SCALE

**RURAL ENTRANCES FOR "3R" PROJECTS**

SHT. 10F 2  
CADD STD. 40630I-D4

F.A.P. RTE.	SECTION	COUNTY	TOTAL SHEETS	SHEET NO.
315/30	1139,138(BC;BC-1)BR,BR-1(BRR)	FULTON	119	59
FED. ROAD DIST. NO.			CONTRACT NO. 68H20	
ILLINOIS FED. AID PROJECT				

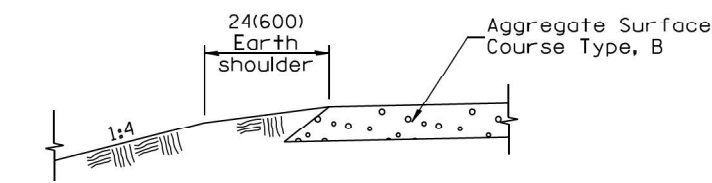

**SECTION A-A**  
SHOULDER TREATMENT FOR AGGREGATE ENTRANCES

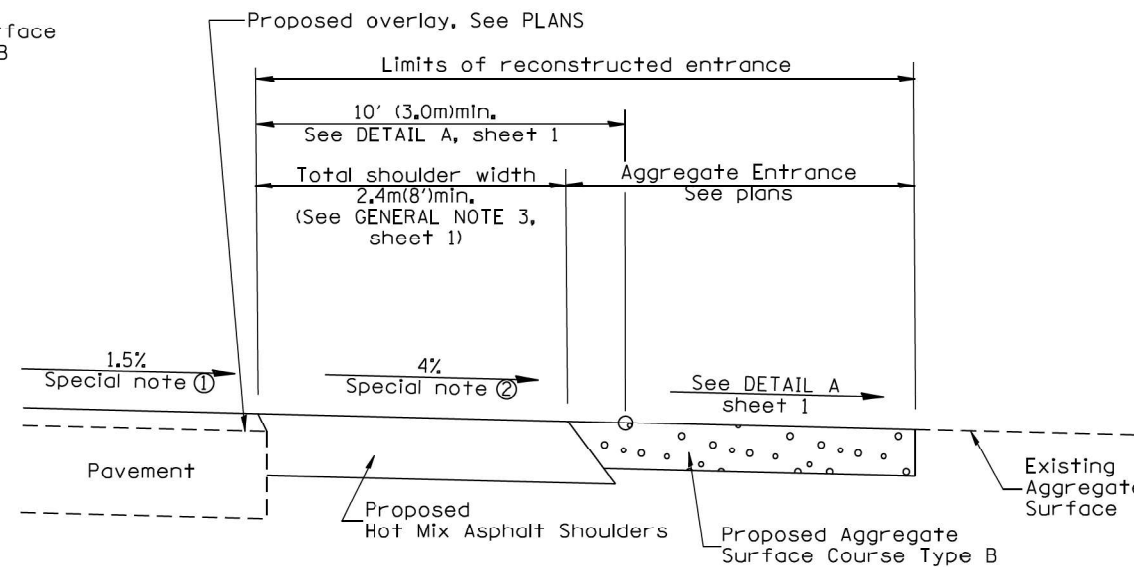

**SECTION B-B**  
RECONSTRUCTED AGGREGATE ENTRANCE

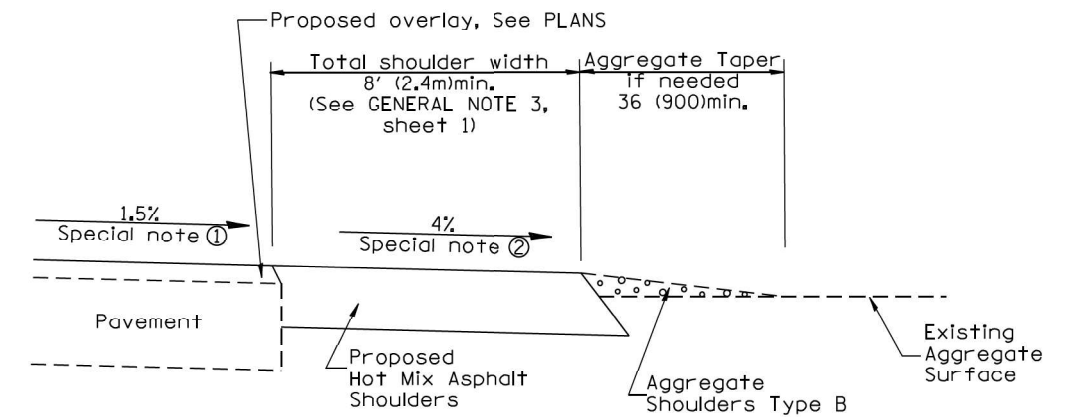

**SECTION B-B**  
EXISTING AGGREGATE ENTRANCE

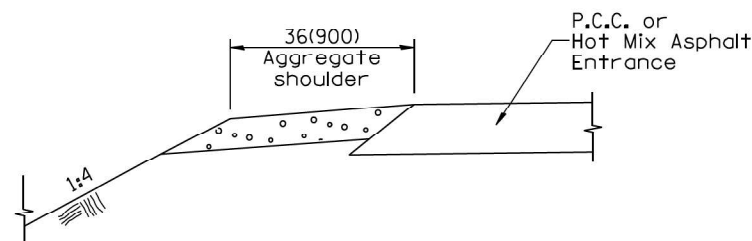

**SECTION C-C**  
SHOULDER TREATMENT FOR P.C.C. OR HOT MIX ASPHALT ENTRANCES

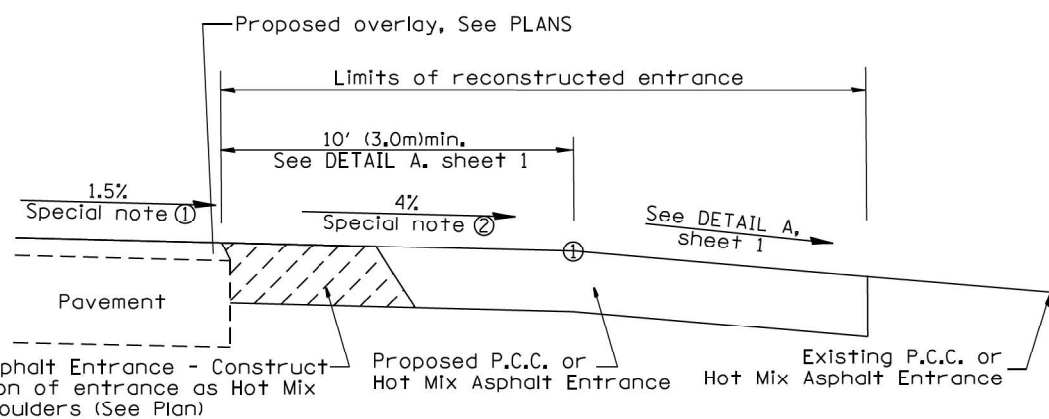

**SECTION D-D**  
RECONSTRUCTED P.C.C. OR HOT MIX ASPHALT ENTRANCE

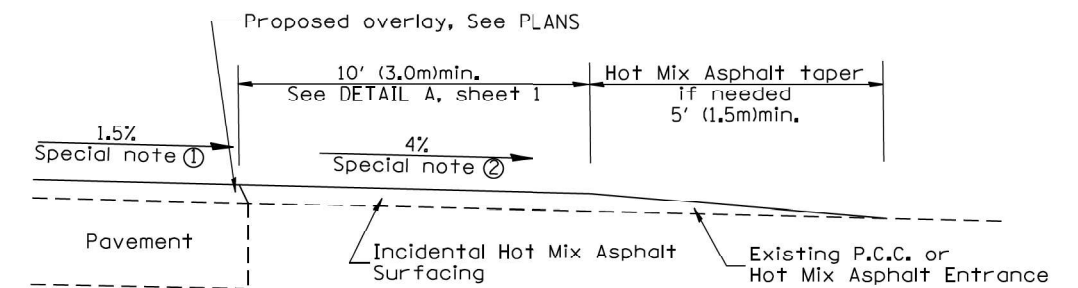

**SECTION D-D**  
EXISTING P.C.C. OR HOT MIX ASPHALT ENTRANCE

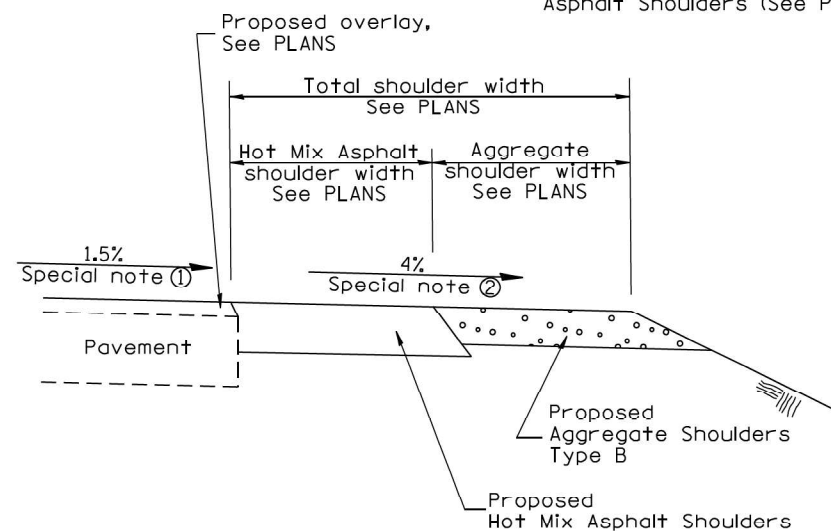

**SECTION E-E**  
MAINLINE SHOULDER TREATMENT

**SPECIAL NOTES**

- ① The mainline pavement cross-slope is 1.5% for tangent alignment. See PLANS for cross-slope on super-elevated horizontal curves.
- ② The shoulder slope shall control the entrance profile for a distance of 10' (3.0m) minimum from the pavement edge. The shoulder cross-slope is 4% for tangent alignment. Through super-elevated curves, the maximum pavement-shoulder breakover should not be greater than 10% for shoulders 6' (1.8m) and wider and 12% for shoulders 4' (1.2m) and less. Where 12' (366cm) paved shoulders are provided, the breakover should be at the edge of the paved shoulder rather than at the pavement edge.

All dimensions are in inches (millimeters) unless otherwise noted.

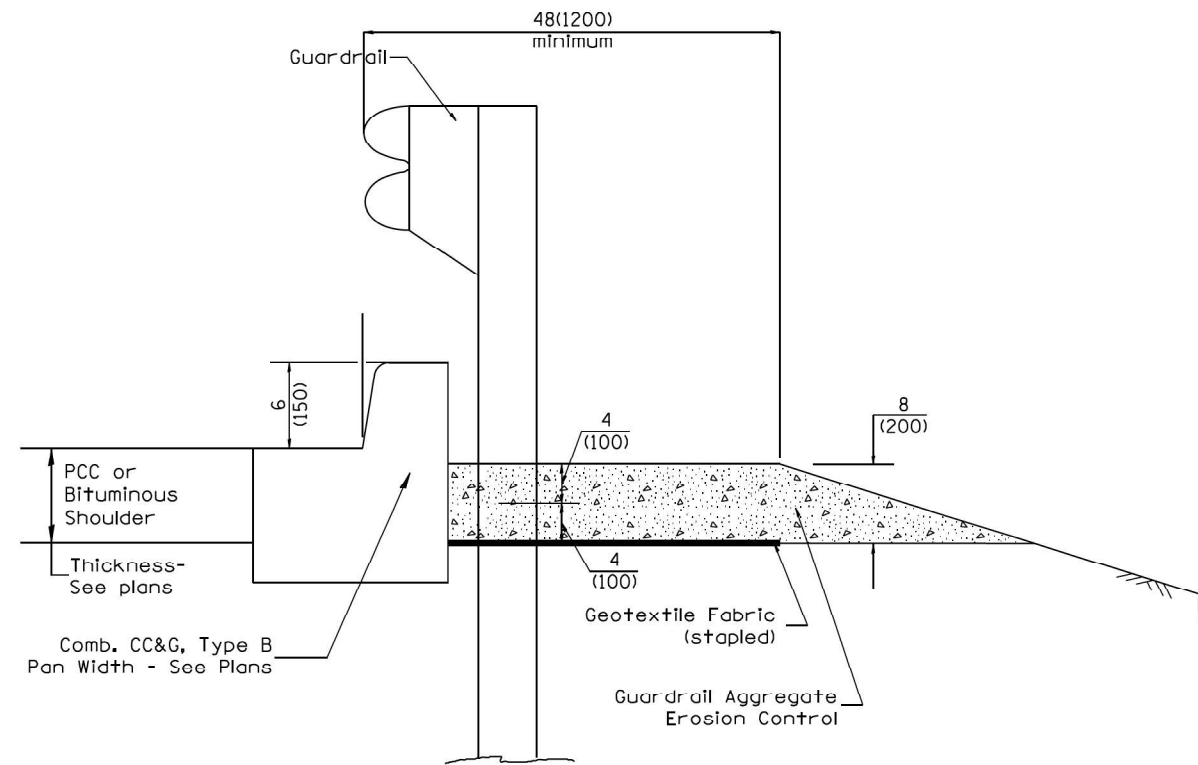

TYPICAL SECTION WITH COMBINATION CONCRETE CURB & GUTTER

**GENERAL NOTES: GUARDRAIL AGGREGATE EROSION CONTROL**

1. This work shall consist of grading as needed, furnishing and installing geotextile fabric and staples, and furnishing, placing and shaping crushed aggregate around and behind Steel Plate Beam Guardrail posts in accordance with Plan Details.
2. Before placing the aggregate and the Geotextile Fabric, weeds and grass shall be removed from the area to be covered.
3. After the area has been prepared, and in a dry condition, the Geotextile fabric shall be placed with a 12(300) minimum overlap. A knife cut for guardrail post installation is necessary.
4. The aggregate shall be deposited, compacted and shaped by either mechanical or hand methods, in a manner reasonably true to line and grade.
5. The Contractor shall have the option of placing the guardrail before or after the Geotextile Fabric and Aggregate are in place. If the guardrail is placed after the Geotextile Fabric and Aggregate, then any voids must be filled and the aggregate returned to line and grade.
6. Materials shall meet the following requirements:
  - A. The crushed aggregate shall be CA1 gradation in accordance with Article 1004.01(c) of the Standard Specifications.
  - B. The Geotextile Fabric shall be nonwoven fabric in accordance with Article 1080.02 of the Standard Specifications.

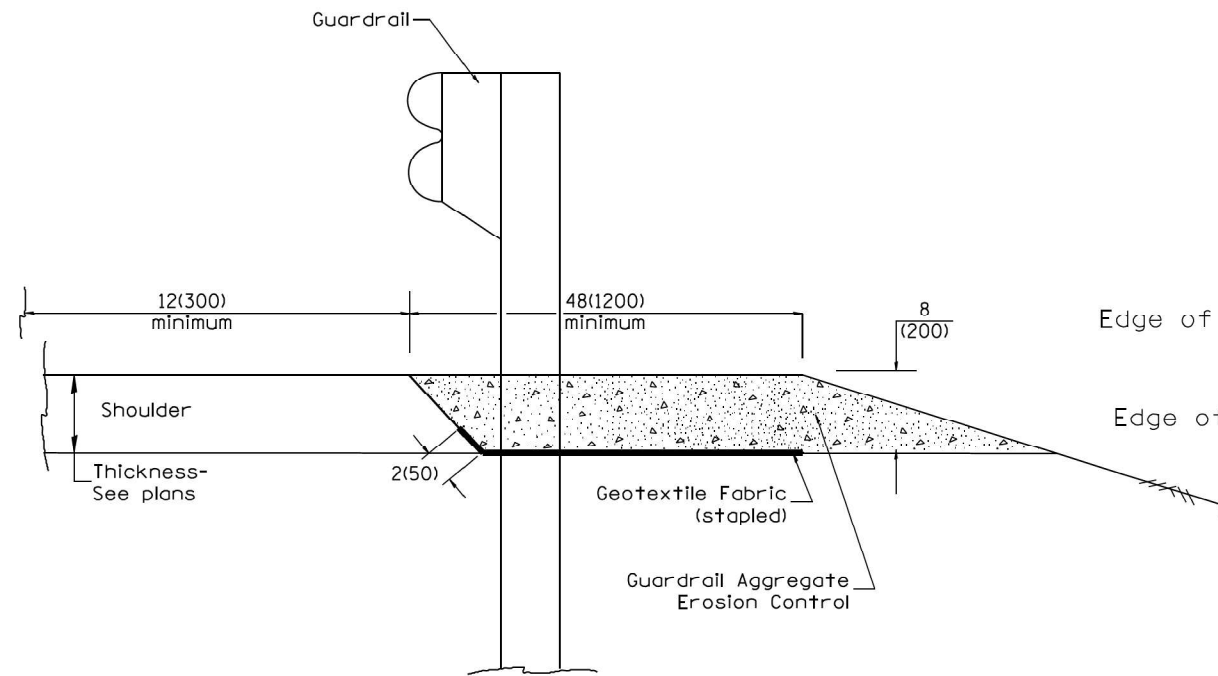

TYPICAL SECTION WITHOUT EROSION CONTROL CURB

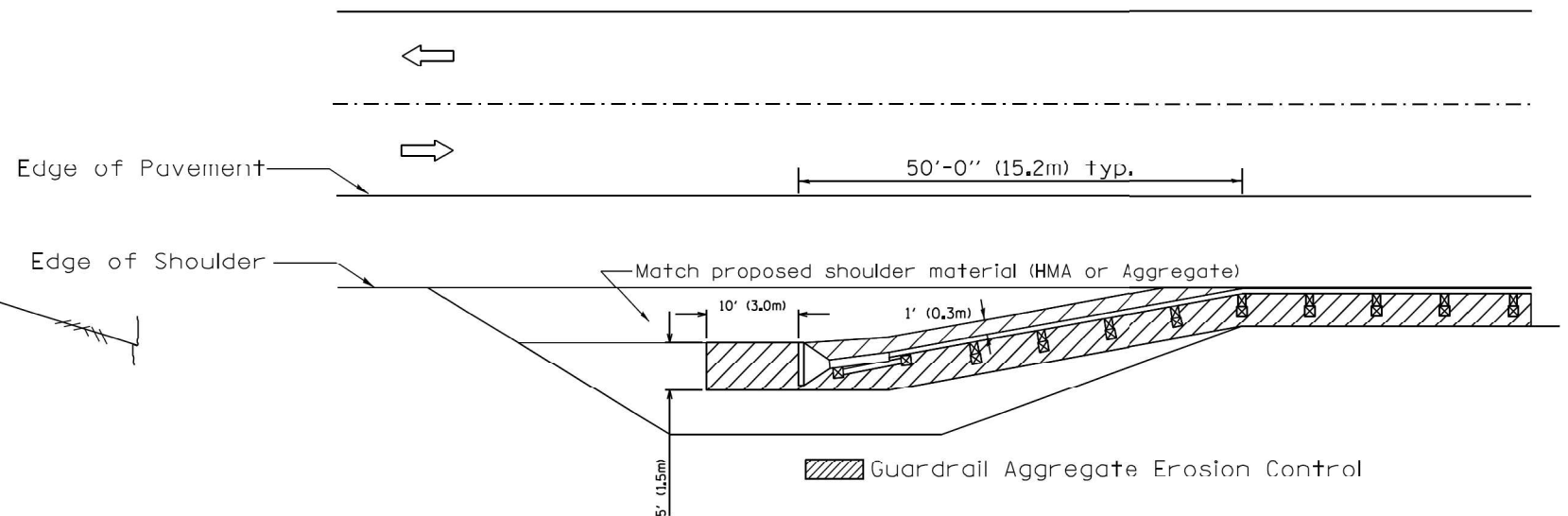

All dimensions are in inches (millimeters) unless otherwise noted.

03-07-11	ADDED DETAIL SHOWING PLAN VIEW	R.D.	5-30-18	CHANGE B CURB TO CC&G	R.D.
08-10-12	REVISED CURB "B" AND AGGREGATE	R.D.	07-16-19	SPELLING CORRECTIONS	R.D.
07-15-15	ADDRESSED SHOULDER INLET CURB	R.D.			
01-26-17	REVISED	R.D.			

STATE OF ILLINOIS  
DEPARTMENT OF TRANSPORTATION

NOT TO SCALE

GUARDRAIL EROSION CONTROL TREATMENTS

SHT. 1 OF 2  
CADD STD. 630101-D4

F.A.P. RTE.	SECTION	COUNTY	TOTAL SHEETS	SHEET NO.
315/30	1139,138(BC;BC-1)BR, BR-1BRR	FULTON	119	61
FED. ROAD DIST. NO. ILLINOIS FED. AID PROJECT			CONTRACT NO. 68H20	

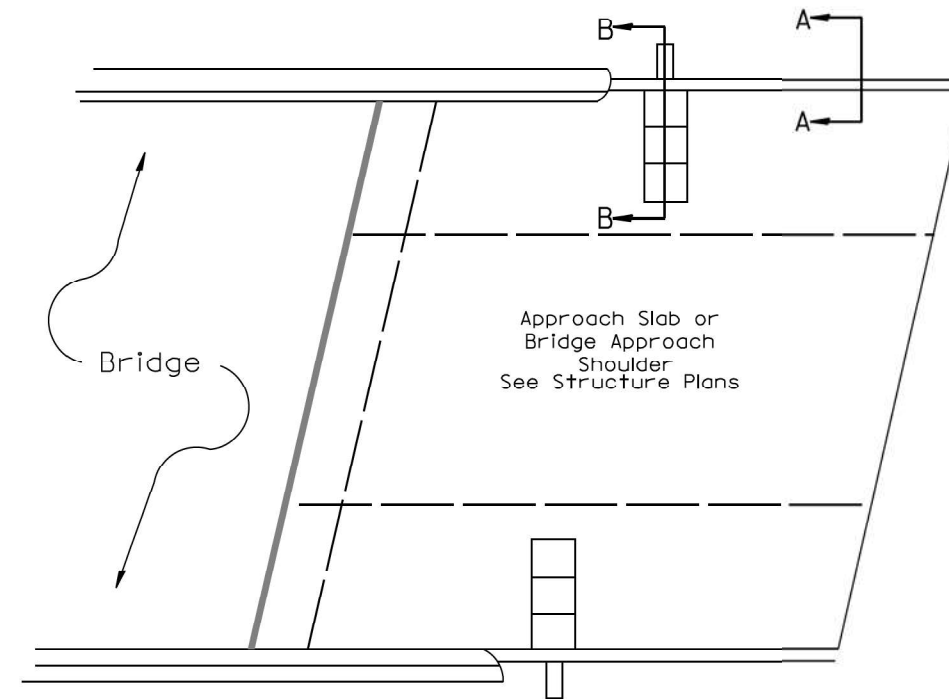
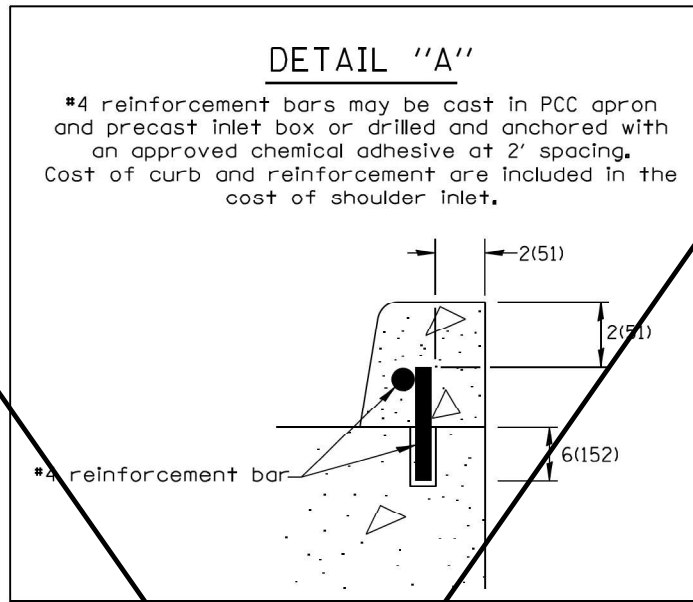

**PLAN VIEW**  
**APPROACH SLAB OR SHOULDER PLACEMENT**

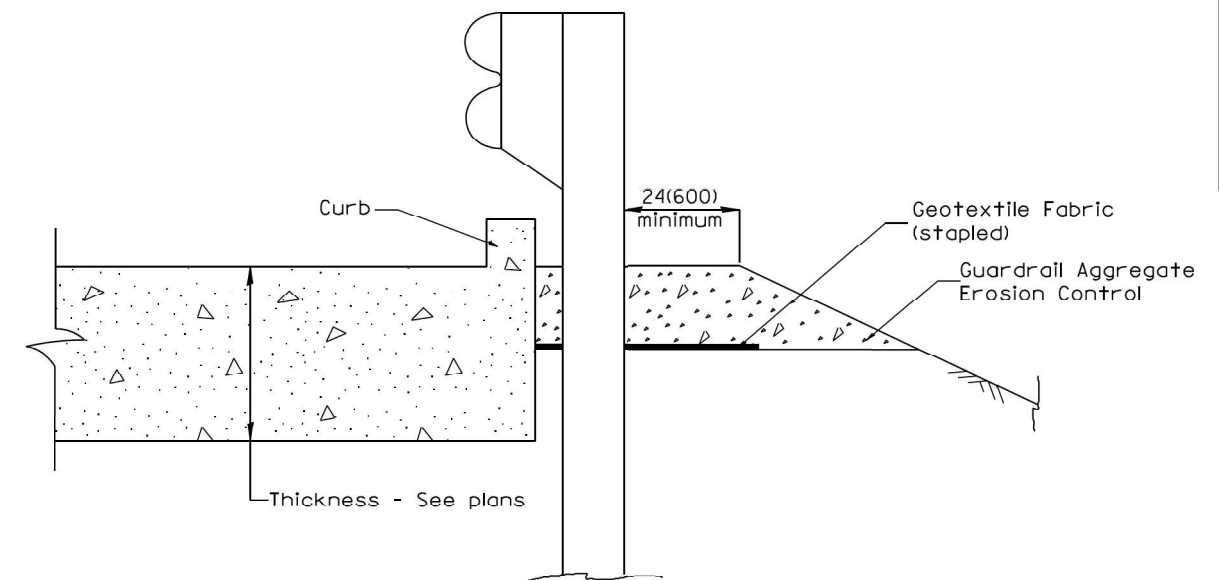
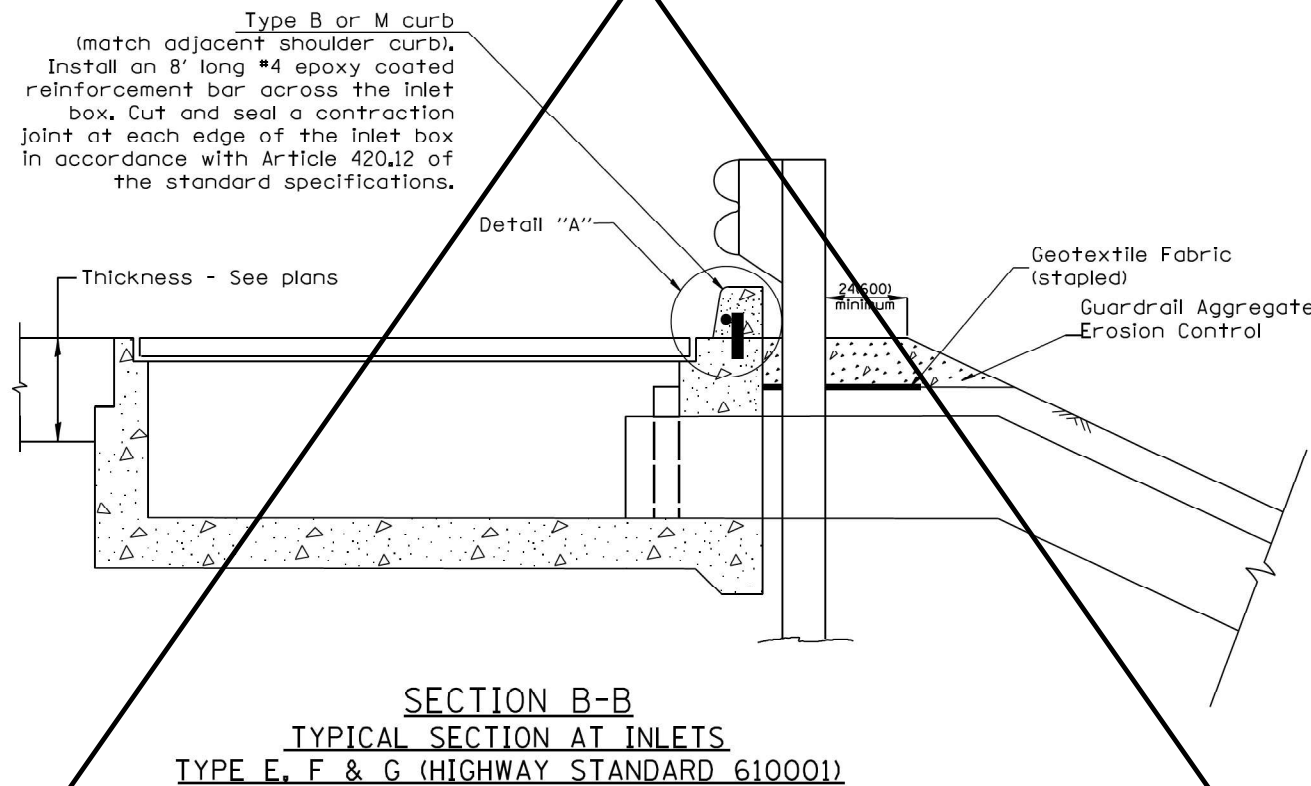

All dimensions are in inches (millimeters) unless otherwise noted.

--	--	--	--	--	--	--	--	--	--

**STATE OF ILLINOIS**  
**DEPARTMENT OF TRANSPORTATION**

NOT TO SCALE

**GUARDRAIL EROSION CONTROL TREATMENTS**

SHT. 2 OF 2  
CADD STD. 630101-D4

F.A.P. RTE.	SECTION	COUNTY	TOTAL SHEETS	SHEET NO.
315/30	1139,138(BC;BC-1)BR, BR-1(BRR)	FULTON	119	62
CONTRACT NO. 68H20				
FED. ROAD DIST. NO.	ILLINOIS	FED. AID PROJECT		

Existing Structure: S.N. 029-0012, originally built in 1936 as four-span continuous wide flange steel beam superstructure with open abutments and mutli-column piers. In 1993 the superstructure was replaced and widened to a out to out width = 39'-2" and back to back length = 234'-2". The substructure units where modified to accomadate new superstructure width. Structure is to be repaired as detailed in these plans. Traffic is to be maintained using stage construction.

No Salvage

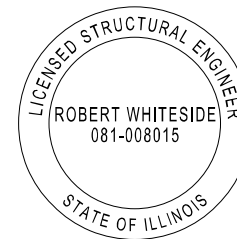

*Robert Whiteside*  
 Robert Whiteside, Illinois S.E. 081-008015  
 Expires 11/30/2024

**SCOPE OF WORK**

1. Replace the transverse expansion joints.
2. Scarify the bridge deck and approach pavements.
3. Complete full depth deck slab repairs.
4. Place a microsilica concrete overlay.
5. Concrete repair of parapets.
6. Steel beam end repairs.
7. Concrete repair of substructure.

**INDEX OF SHEETS**

1. General Plan and Elevation
2. General Data
3. Stage Construction Details
4. Temporary Concrete Barrier
5. Deck Overlay Plan
6. South Parapet Repairs
- 7-8. Expansion Joint Details
9. Preformed Joint Strip Seal
10. Beam End Repairs
11. Abutment Repairs
12. Pier 1 Repairs
13. Bar Splicer Assembly and Mechanical Splicer Details
14. Existing Plans Reference Sheet

**DESIGN SPECIFICATIONS**

2002 AASHTO Standard Specifications for Highway Bridges - LFD

**DESIGN STRESSES**

**FIELD UNITS (EXIST. CONST.)**

$f'_c = 3,500$  psi  
 $f_y = 60,000$  psi (Reinforcement)  
 $f_y = 50,000$  psi (Structural Steel M270 Grade 50)  
 $f_y = 36,000$  psi (Structural Steel M270 Grade 36)

**FIELD UNITS (NEW CONST.)**

$f'_c = 4,000$  psi  
 $f_y = 60,000$  psi (Reinforcement)  
 $f_y = 50,000$  psi (M270 Grade 50)

**LOADING HS-20**

Existing and Proposed

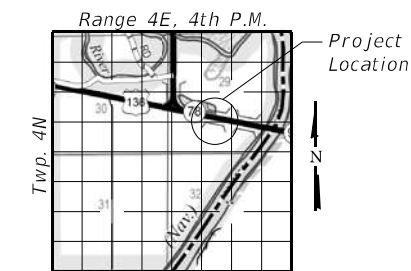

LOCATION SKETCH

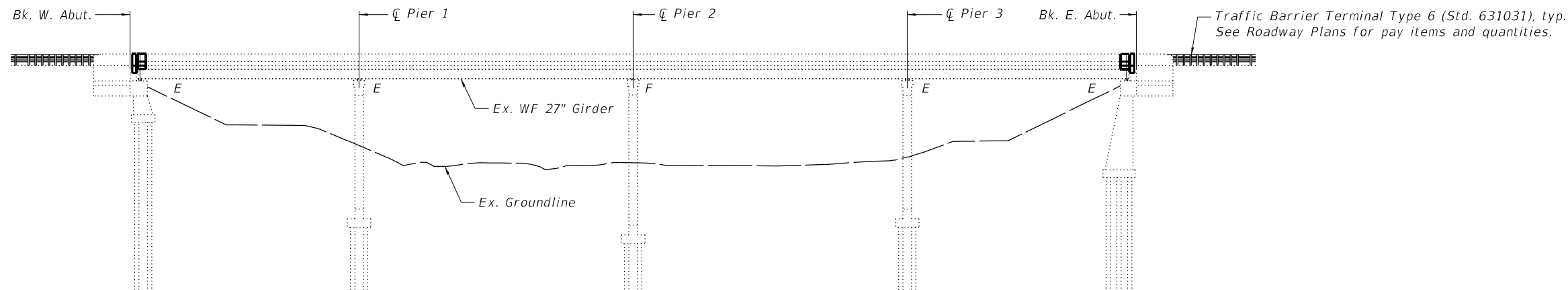

ELEVATION

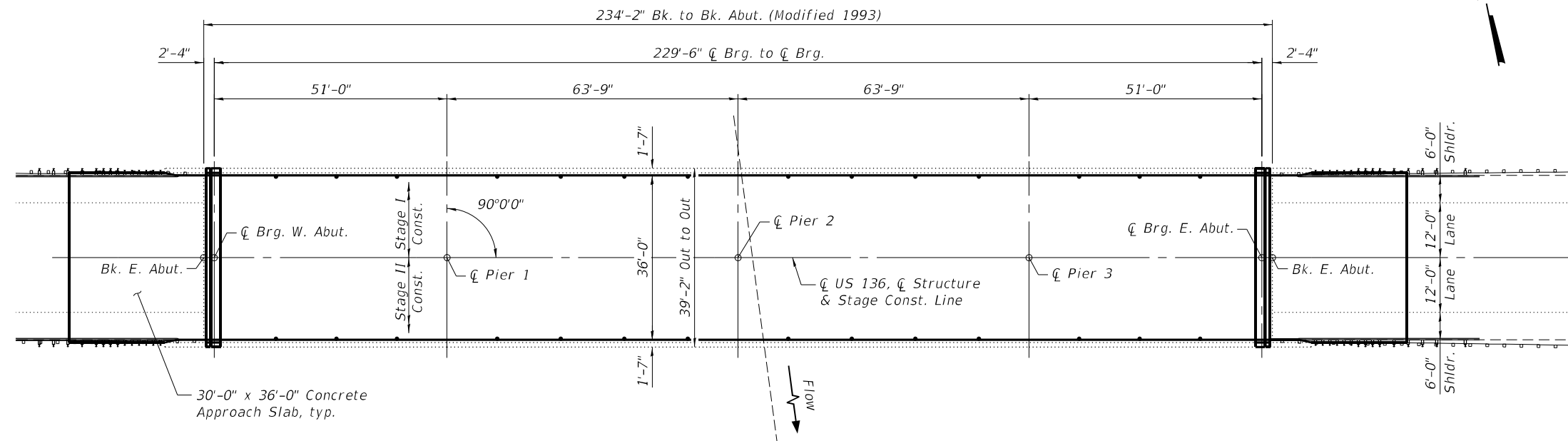

PLAN

**GENERAL PLAN & ELEVATION**

US 136 OVER LACY DITCH

FAP ROUTE 315

SECTION [139,138(BC;BC-1)BR,BR-1]BRR

FULTON COUNTY

STRUCTURE NO. 029-0012

MODEL: \$MODELNAME\$  
 FILE NAME: \$FILES\$



USER NAME = \$USERS\$	DESIGNED - CFS	REVISED -
\$FILES\$	CHECKED - RPW	REVISED -
PLOT SCALE = \$SCALE\$	DRAWN - CFS	REVISED -
PLOT DATE =	CHECKED - MDC	REVISED -

STATE OF ILLINOIS  
 DEPARTMENT OF TRANSPORTATION

GENERAL PLAN AND ELEVATION  
 STRUCTURE NO. 029-0012

SHEET 1 OF 14 SHEETS

F.A.P. RTE.	SECTION	COUNTY	TOTAL SHEETS	SHEET NO.
315	[139,138(BC;BC-1)BR,BR-1]BRR	FULTON	119	63
CONTRACT NO. 68H20				
ILLINOIS FED. AID PROJECT				

**GENERAL NOTES**

Fasteners shall be ASTM A325 Type 1, mechanically galvanized bolts. Bolts 3/4" Ø, holes 15/16" Ø, unless otherwise noted.

Calculated weight of Structural Steel = 860 lbs (M270 Grade 50).

All structural steel shall be AASHTO M270 Grade 50, unless otherwise noted.

No field welding is permitted except as specified in the contract documents.

Reinforcement bars designated (E) shall be epoxy coated.

Plan dimensions and details relative to existing plans are subject to nominal construction variations. The Contractor shall field verify existing dimensions and details affecting new construction and make necessary approved adjustments prior to construction or ordering of materials. Such variations shall not be cause for additional compensation for a change in scope of the work, however, the Contractor will be paid for the quantity actually furnished at the unit price bid for the work.

Existing reinforcement bars extending into the removal area shall be cleaned and incorporated into the new construction. Any reinforcement bars that are damaged during concrete removal shall be replaced with an approved bar splicer or anchorage system. Cost included with Concrete Removal.

Prior to pouring the new concrete deck, all heavy or loose rust, loose mill scale, and other loose or potentially detrimental foreign material shall be removed from the surfaces in contact with concrete. Tightly adhered paint may remain unless otherwise noted. Removal shall be accomplished by methods that will not damage the steel and the cost will be included in the pay item covering removal of the existing concrete.

The protective coat shall be applied to the new microsilica concrete overlay, new bridge deck concrete, and top and inside faces of the new portions of the parapets and wingwalls.

Joint openings shall be adjusted according to Article 520.04 of the Standard Specifications when the deck is poured at an ambient temperature other than 50°F.

All repair materials including structural steel angles, bolts, nuts and washers shall be galvanized per the special provision "Hot Dip Galvanizing for Structural Steel". Cost included in Structural Steel Repair.

**TOTAL BILL OF MATERIAL**

Item	Unit	Super	Sub	Total
Concrete Removal	Cu. Yd.	10.7	-	10.7
Concrete Superstructure	Cu. Yd.	12.0	-	12.0
Bridge Deck Grooving	Sq. Yd.	1,107	-	1,107
Protective Coat	Sq. Yd.	1,182	-	1,182
Reinforcement Bars, Epoxy Coated	Pound	1,800	-	1,800
Bar Splicers	Each	26	-	26
Preformed Joint Strip Seal	Foot	76	-	76
Structural Steel Repair	Pound	860	-	860
Bridge Deck Scarification 3/4"	Sq. Yd.	1,153	-	1,153
Bridge Deck Microsilica Concrete Overlay 2 1/4"	Sq. Yd.	1,153	-	1,153
Structural Repair of Concrete (Depth Equal to or Less than 5 inches)	Sq. Ft.	7	6	13

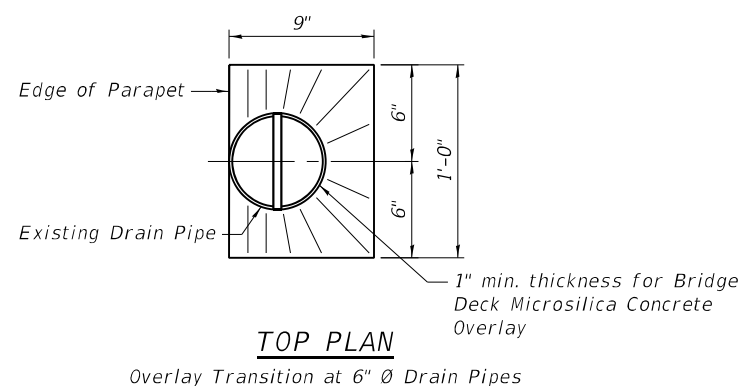

MODEL: \$MODELNAME\$  
FILE NAME: \$FILES\$



QUIGG ENGINEERING INC

USER NAME = \$USER\$	DESIGNED - CFS	REVISED -
\$FILE\$	CHECKED - RPW	REVISED -
PLOT SCALE = \$SCALE\$	DRAWN - CFS	REVISED -
PLOT DATE =	CHECKED - MDC	REVISED -

**STATE OF ILLINOIS  
DEPARTMENT OF TRANSPORTATION**

**GENERAL DATA  
STRUCTURE NO. 029-0012**

SHEET 2 OF 14 SHEETS

F.A.P. RTE.	SECTION	COUNTY	TOTAL SHEETS	SHEET NO.
315	[139,138(BC;BC-1)BR,BR-1]BRR	FULTON	119	64
CONTRACT NO. 68H20				
ILLINOIS		FED. AID PROJECT		

SDATE\$ \$TIME\$



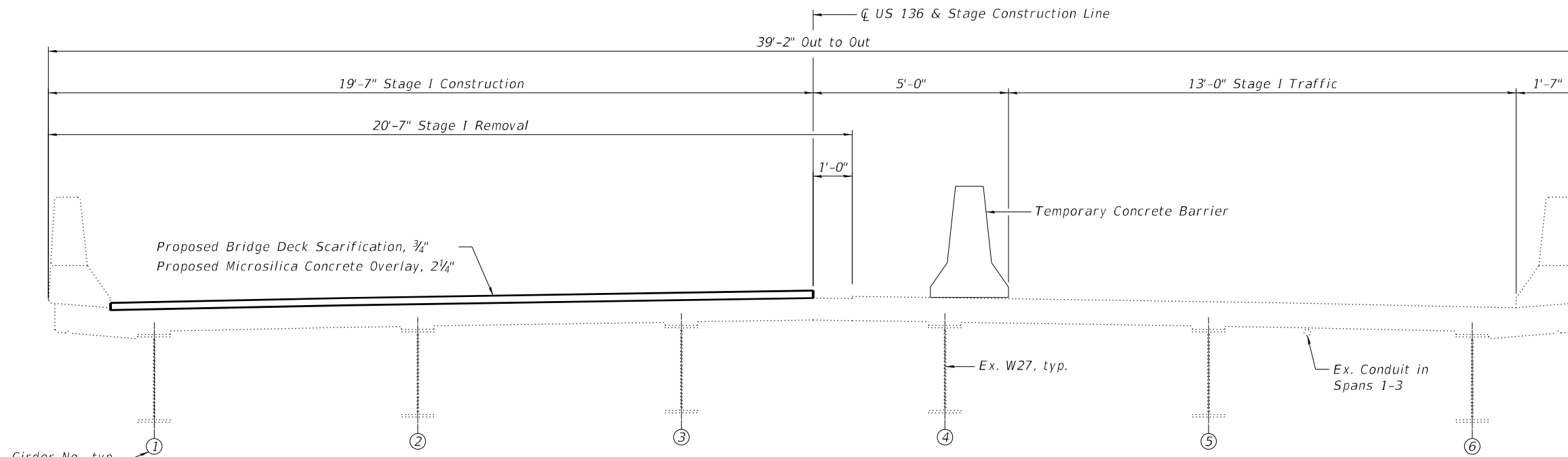

**STAGE I CONSTRUCTION**

(Looking East)

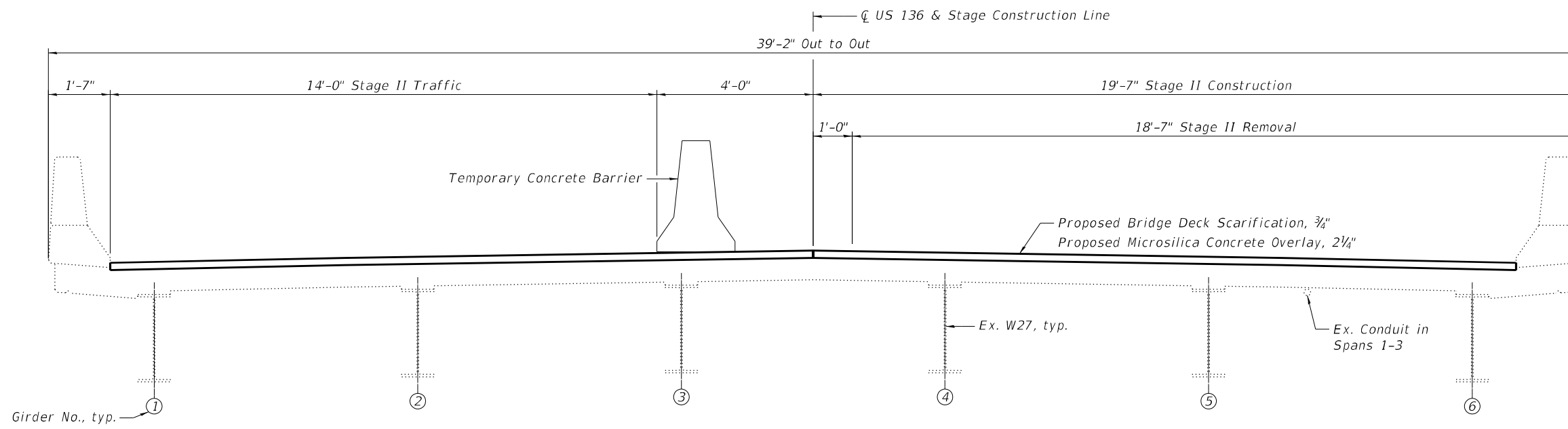

**STAGE II CONSTRUCTION**

(Looking East)

MODEL: \$MODELNAME\$  
FILE NAME: \$FILES



QUIGG ENGINEERING INC

USER NAME = \$USER\$	DESIGNED - CFS	REVISED -
\$FILES	CHECKED - RPW	REVISED -
PLOT SCALE = \$SCALE\$	DRAWN - CFS	REVISED -
PLOT DATE =	CHECKED - MDC	REVISED -

STATE OF ILLINOIS  
DEPARTMENT OF TRANSPORTATION

STAGE CONSTRUCTION DETAILS  
STRUCTURE NO. 029-0012

SHEET 3 OF 14 SHEETS

F.A.P. RTE.	SECTION	COUNTY	TOTAL SHEETS	SHEET NO.
315	[139,138(BC;BC-1)BR,BR-1]BRR	FULTON	119	65
CONTRACT NO. 68H20				
ILLINOIS FED. AID PROJECT				

\$DATE\$ \$TIME\$

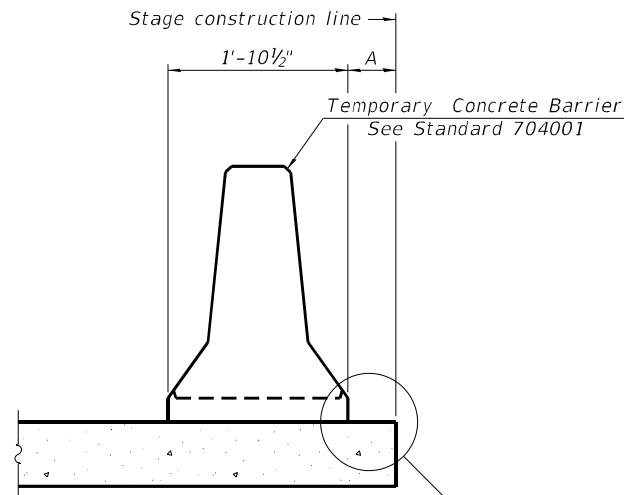

When "A" is 3'-1" or less, the temporary concrete barrier shall be restrained to the new slab according to Detail I, II or III. No restraint is required when "A" is greater than 3'-1".

NEW SLAB OR NEW DECK BEAM

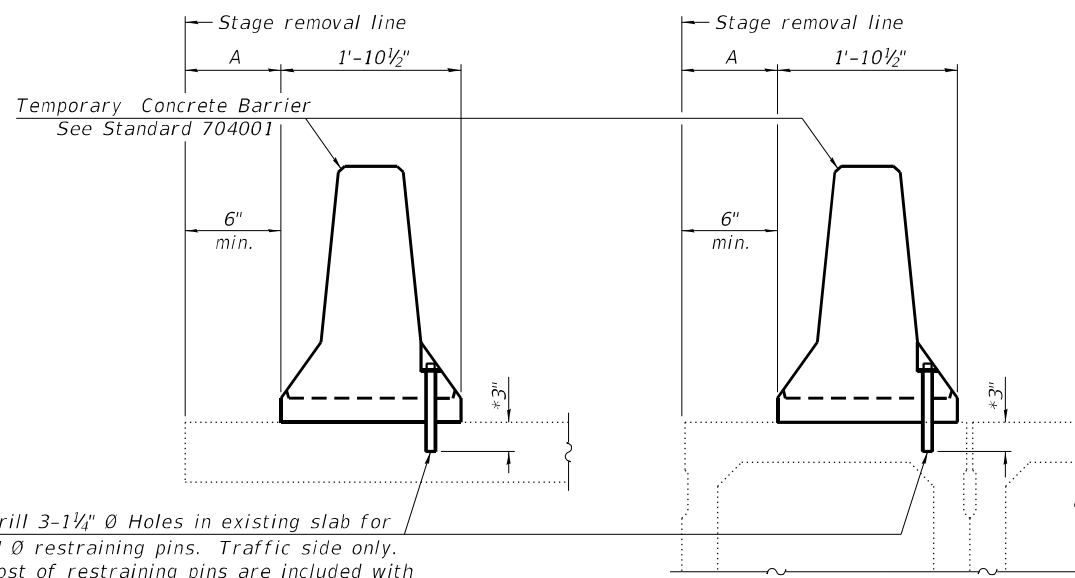

Drill 3-1/4" Ø Holes in existing slab for 1" Ø restraining pins. Traffic side only. Cost of restraining pins are included with Temporary Concrete Barrier. No restraint is required when "A" is greater than 3'-1".

EXISTING SLAB

\* When hot-mix asphalt wearing surface is present, embedment shall be 3" plus the wearing surface depth.

EXISTING DECK BEAM

SECTIONS THRU SLAB OR DECK BEAM

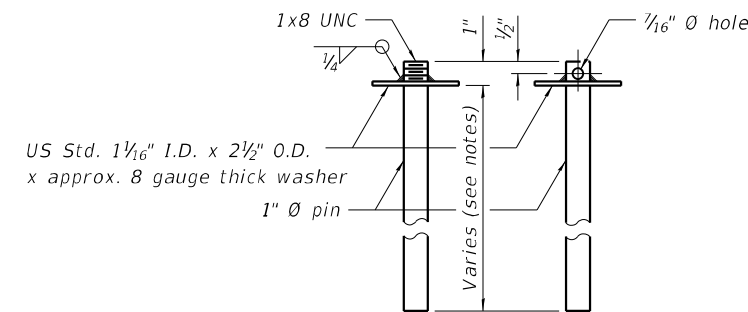

RESTRAINING PIN

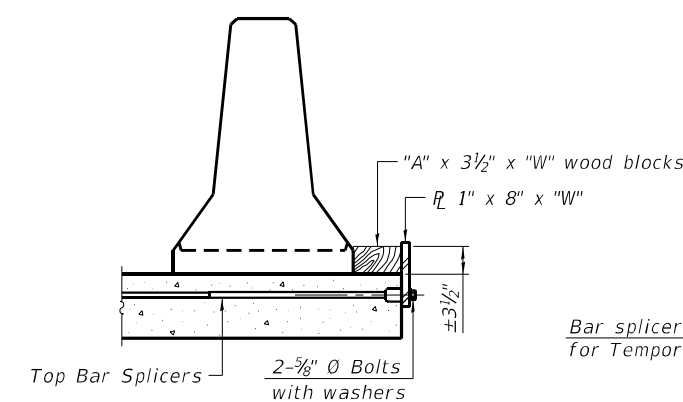

DETAIL I

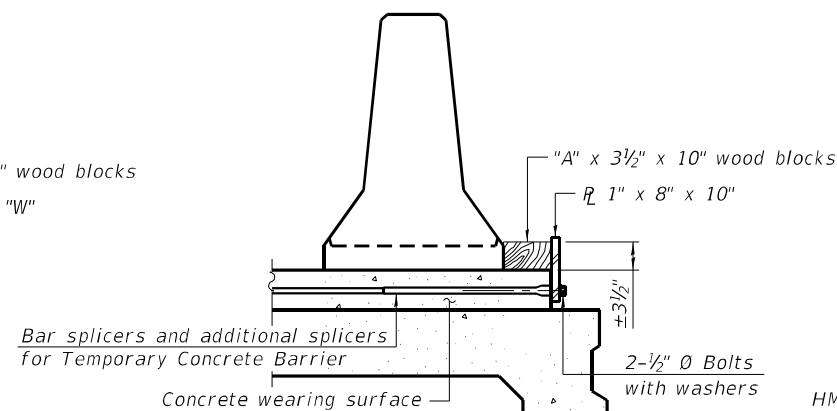

DETAIL II

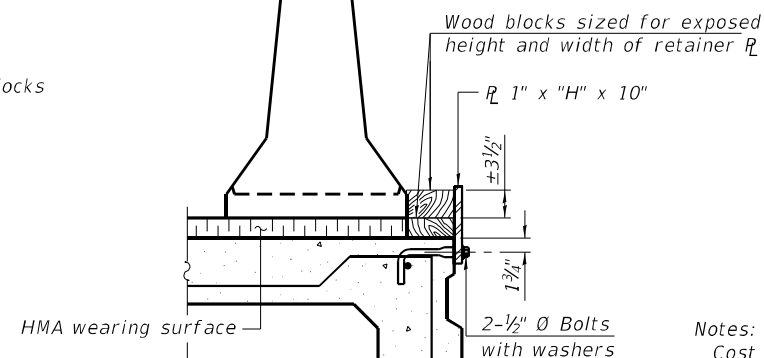

DETAIL III

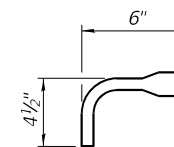

BAR SPLICER FOR #4 BAR - DETAIL III

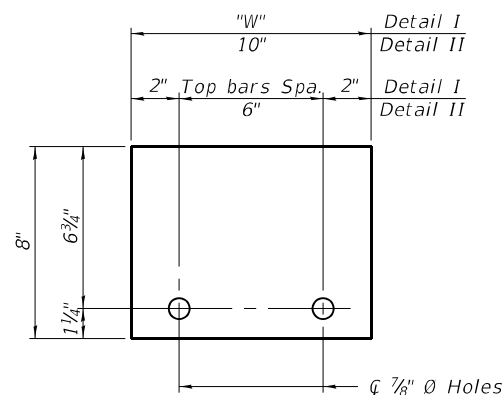

STEEL RETAINER R 1" x 8" x "W"  
(Detail I and II)

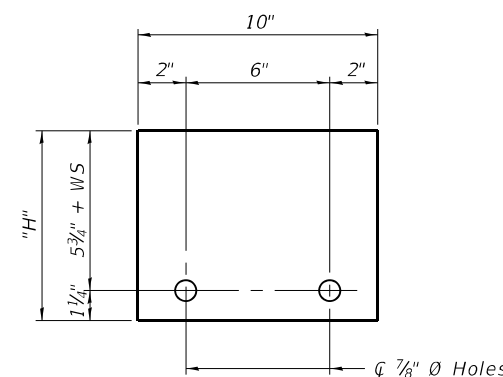

STEEL RETAINER R 1" x "H" x 10"  
(Detail III)

Notes:  
 Cost of retainer assembly is included with Temporary Concrete Barrier.  
 A retainer assembly shall be located at the approximate  $\frac{1}{2}$  of each temporary concrete barrier.  
 The retainer plate shall not be removed until the concrete on the adjacent stage is ready to be poured. For Detail III applications the retainer plate shall not be removed until just prior to placing the adjacent beam.  
 When the 'A' dimension is less than 1 1/2', the wood block shall be omitted and the barrier shall be placed in direct contact with the steel retainer plate. For deck beam applications the minimum required 'A' distance is 6" to accommodate the shear key clamping device.

Detail I - Installation for a new bridge deck or bridge slab.  
 Detail II - Installation for a new deck beam with an initial concrete wearing surface. Additional bar splicers shall be provided at 6'-0" centers and paired with the bar splicers of the concrete wearing surface reinforcement to accommodate the installation of the retainer assemblies. The cost of the additional bar splicers is included with the concrete wearing surface.  
 Detail III - Installation for a new deck beam with no initial wearing surface or with an initial hot-mix asphalt (HMA) wearing surface present. The deck beam directly beneath the temporary concrete barrier shall be fabricated with bar splicer inserts in the side of the beam, as detailed, to accommodate the installation of the retainer assemblies. A pair of bar splicers, 6" apart, shall be placed at 6'-0" centers along the length of the beam. The cost of the bar splicers is included with the deck beam.

RAILING CRITERIA

NCHRP 350 Test Level	3
Railing Weight (plf)	440

R-27 10-12-2021

MODEL: \$MODELNAME\$  
FILE NAME: \$FILES\$



USER NAME = \$USERS\$	DESIGNED - CFS	REVISED -
\$FILES\$	CHECKED - RPW	REVISED -
PLOT SCALE = \$SCALE\$	DRAWN - CFS	REVISED -
PLOT DATE =	CHECKED - MDC	REVISED -

STATE OF ILLINOIS  
DEPARTMENT OF TRANSPORTATION

TEMPORARY CONCRETE BARRIER  
STRUCTURE NO. 029-0012

SHEET 4 OF 14 SHEETS

F.A.P. RTE.	SECTION	COUNTY	TOTAL SHEETS	SHEET NO.
315	[139,138/BC/BC-1]BR, BR-1]BRR	FULTON	119	66
CONTRACT NO. 68H20				
ILLINOIS FED. AID PROJECT				

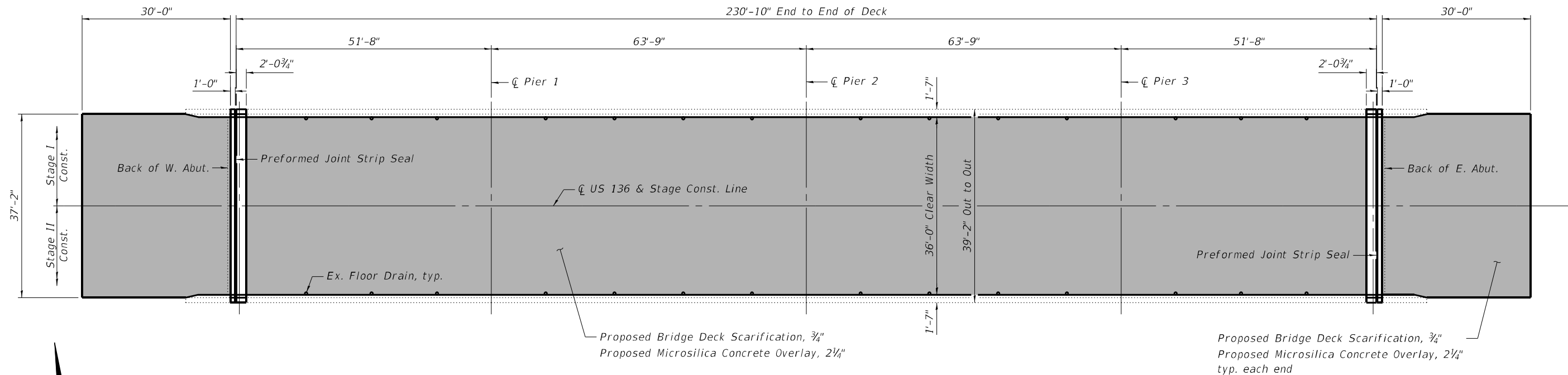

**PLAN**

**LEGEND**

■ Scarification and Microsilica Concrete Overlay Limits

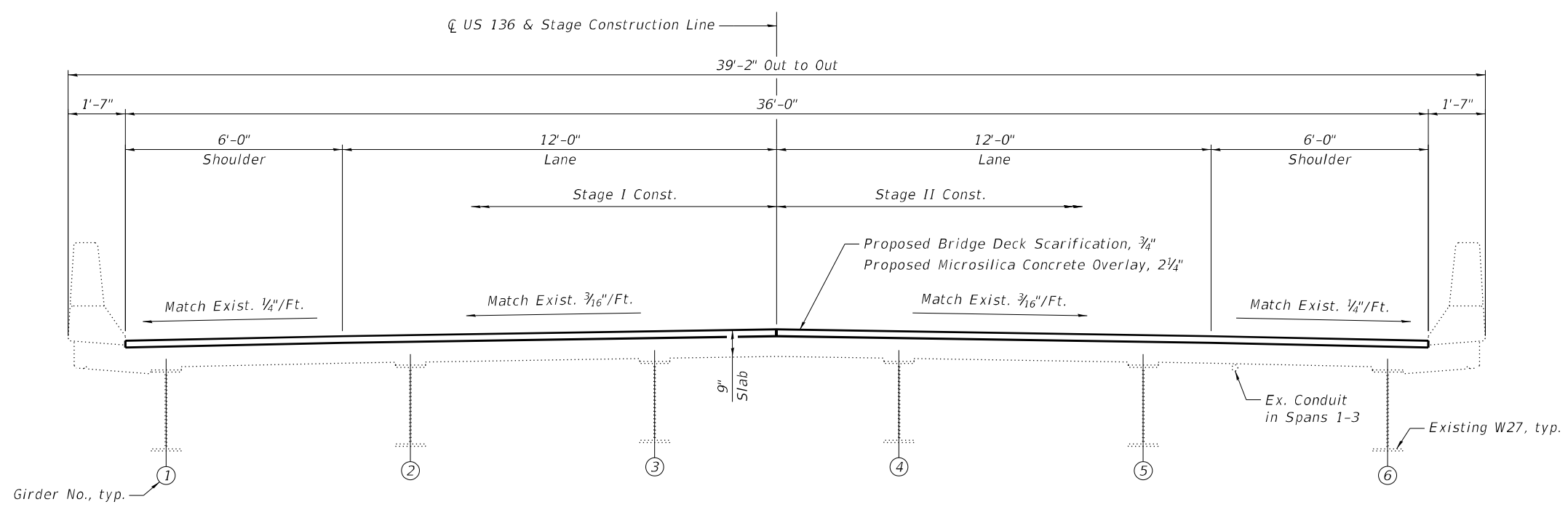

**CROSS SECTION**  
(Looking East)

**BILL OF MATERIAL**

Item	Unit	Total
Bridge Deck Grooving	Sq. Yd.	1,107
Protective Coat	Sq. Yd.	1,182
Bridge Deck Scarification, 3/4"	Sq. Yd.	1,153
Microsilica Concrete Overlay, 2 1/4"	Sq. Yd.	1,153

Note:  
See Sheet 2 of 14 for overlay details at drain pipes.  
See Sheets 7 thru 9 of 14 for expansion joint details.

MODEL: \$MODELNAME\$  
FILE NAME: \$FILES\$



USER NAME = \$USERS\$	DESIGNED - CFS	REVISED -
\$FILESS\$	CHECKED - RPW	REVISED -
PLOT SCALE = \$SCALE\$	DRAWN - CFS	REVISED -
PLOT DATE =	CHECKED - MDC	REVISED -

**STATE OF ILLINOIS**  
**DEPARTMENT OF TRANSPORTATION**

**DECK OVERLAY PLAN**  
**STRUCTURE NO. 029-0012**

SHEET 5 OF 14 SHEETS

F.A.P. RTE.	SECTION	COUNTY	TOTAL SHEETS	SHEET NO.
315	[139,138(BC;BC-1)BR,BR-1]BRR	FULTON	119	67
CONTRACT NO. 68H20				
ILLINOIS FED. AID PROJECT				



INSIDE FACE OF SOUTH PARAPET  
(Looking South)



INSIDE FACE OF SOUTH PARAPET  
(Looking South)



INSIDE FACE OF SOUTH PARAPET  
(Looking South)



INSIDE FACE OF SOUTH PARAPET  
(Looking South)

**LEGEND**

Structural Repair of Concrete (Depth Equal to or less than 5")

Note:  
See Sheets 7 thru 9 of 14 for expansion joint details.

**BILL OF MATERIAL**

Item	Unit	Total
Structural Repair of Concrete (Depth Equal to or less than 5")	Sq. Ft.	7

MODEL: \$MODELNAME\$  
FILE NAME: \$FILES



QUIGG ENGINEERING INC

USER NAME = \$USER\$	DESIGNED - CFS	REVISED -
\$FILE\$	CHECKED - RPW	REVISED -
PLOT SCALE = \$SCALE\$	DRAWN - CFS	REVISED -
PLOT DATE =	CHECKED - MDC	REVISED -

STATE OF ILLINOIS  
DEPARTMENT OF TRANSPORTATION

SOUTH PARAPET REPAIRS  
STRUCTURE NO. 029-0012

SHEET 6 OF 14 SHEETS

F.A.P. RTE.	SECTION	COUNTY	TOTAL SHEETS	SHEET NO.
315	[139,138(BC;BC-1)BR,BR-1]BRR	FULTON	119	68
CONTRACT NO. 68H20				
ILLINOIS		FED. AID PROJECT		

\$DATE\$ \$TIME\$

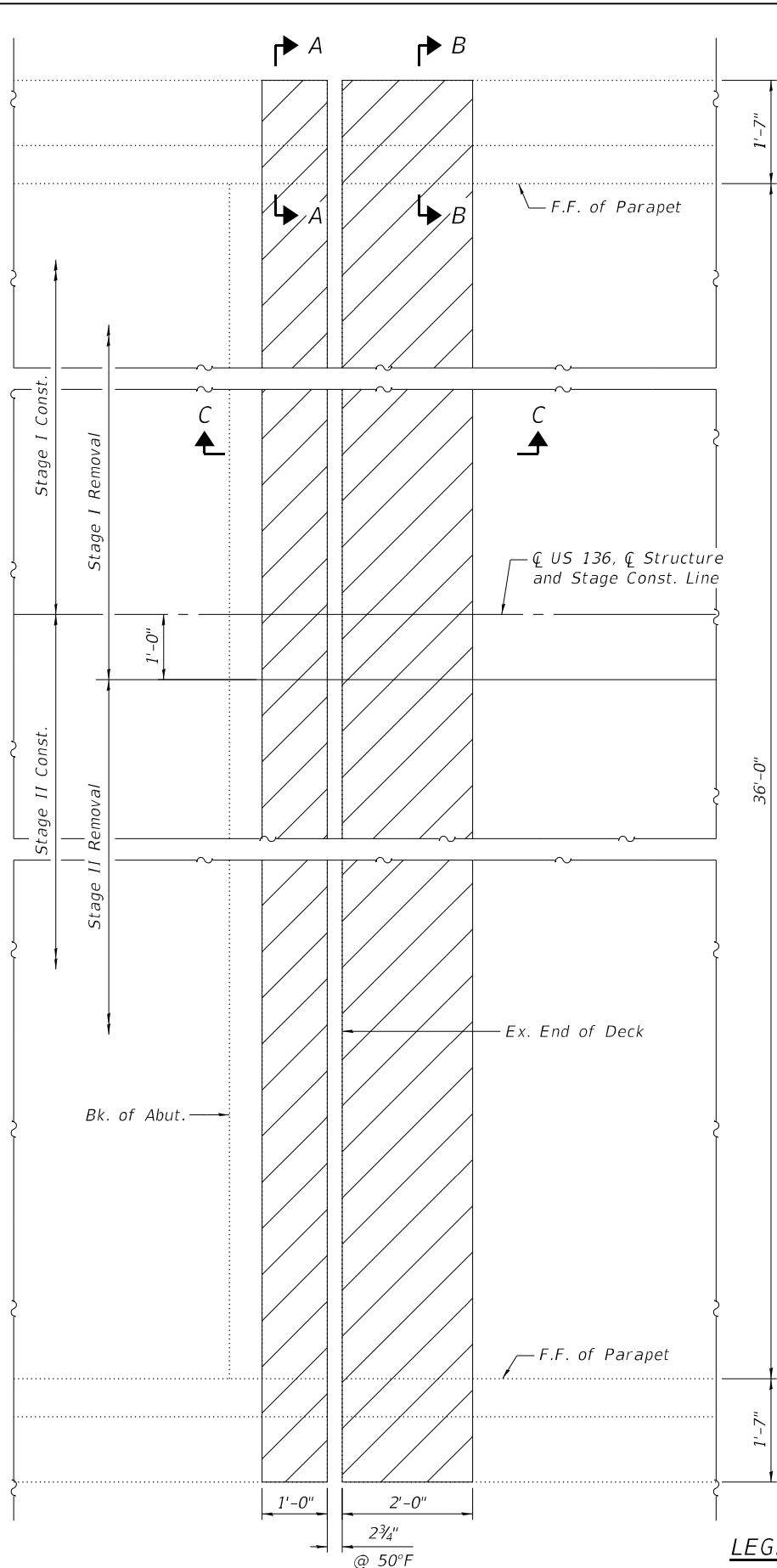

**CONCRETE REMOVAL PLAN**  
(West Abutment Shown, East Abutment Similar)

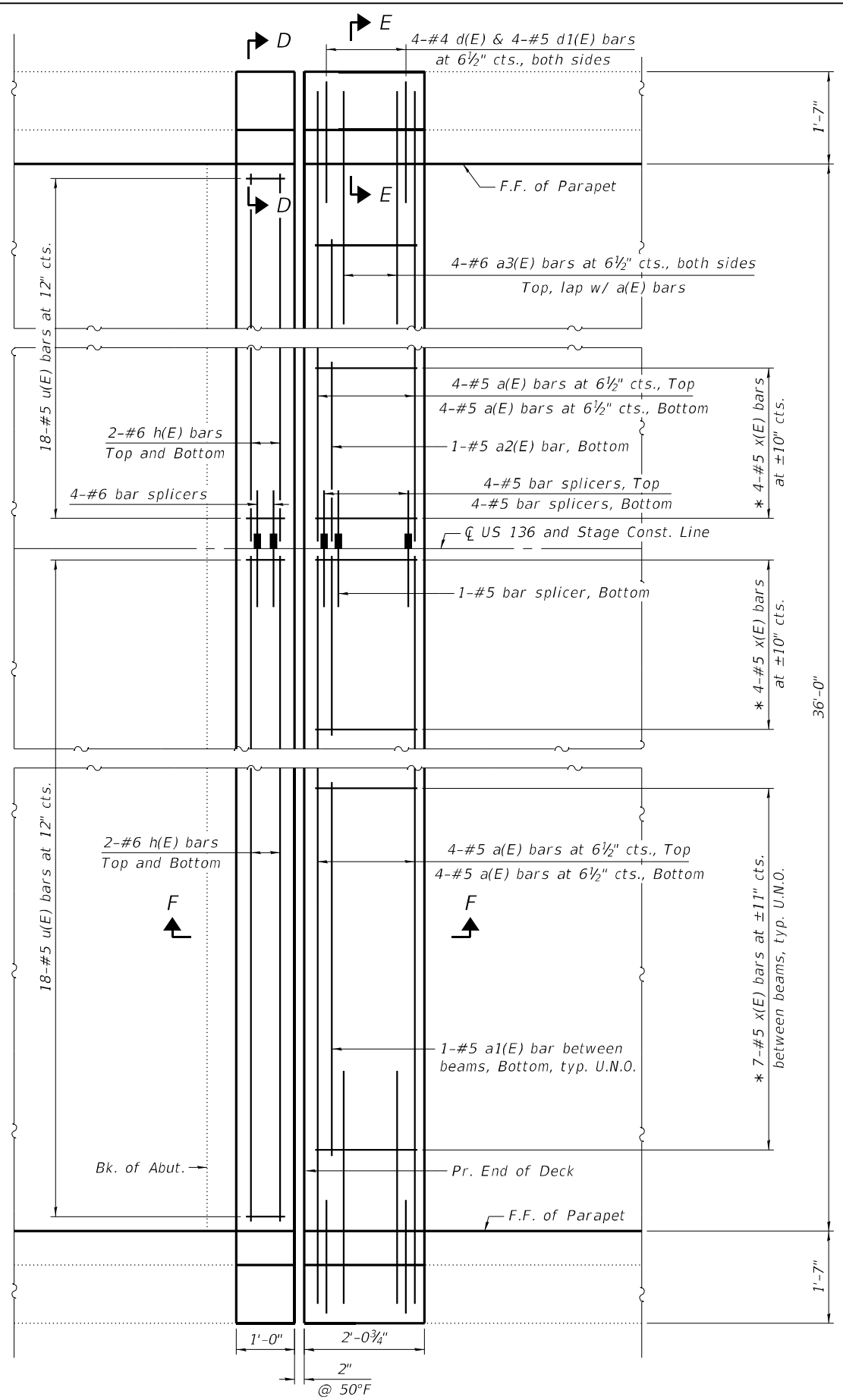

**CONCRETE REPLACEMENT PLAN**  
(West Abutment Shown, East Abutment Similar)

**LEGEND**  
 Concrete Removal

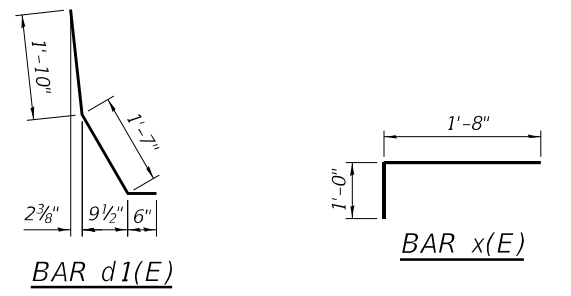
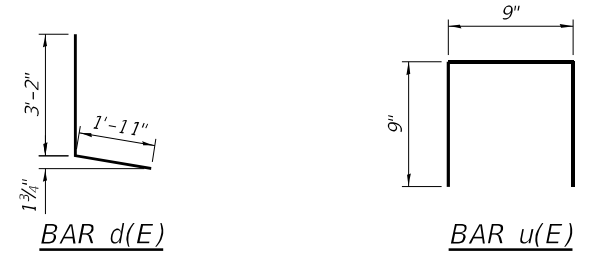

**Notes:**  
 Any reinforcement bars that are to remain that are damaged during concrete removal operations shall be repaired or replaced using an approved bar splicer or anchorage system. Cost included with Concrete Removal.  
 Existing longitudinal and vertical reinforcement bars remaining and extending into the removal areas shall be cleaned, straightened and incorporated into the new construction. Cost included with Concrete Removal.  
 See Sheet 8 of 14 for sections.  
 See Sheet 5 of 14 for overlay details.  
 See Sheet 9 of 14 for joint seal details.

\* Cut to fit

**BILL OF MATERIAL**

Bar	No.	Size	Length	Shape	
a(E)	32	#5	18'-7"	—	
a1(E)	8	#5	6'-5"	—	
a2(E)	2	#5	3'-1"	—	
a3(E)	16	#6	7'-4"	—	
d(E)	16	#4	5'-1"	L	
d1(E)	16	#5	3'-11"	∩	
h(E)	16	#6	17'-8"	—	
u(E)	72	#5	2'-3"	U	
x(E)	72	#5	2'-8"	L	
Item				Unit	Total
Concrete Removal				Cu. Yd.	10.7
Concrete Superstructure				Cu. Yd.	12.0
Reinforcement Bars, Epoxy Coated				Pound	1,800

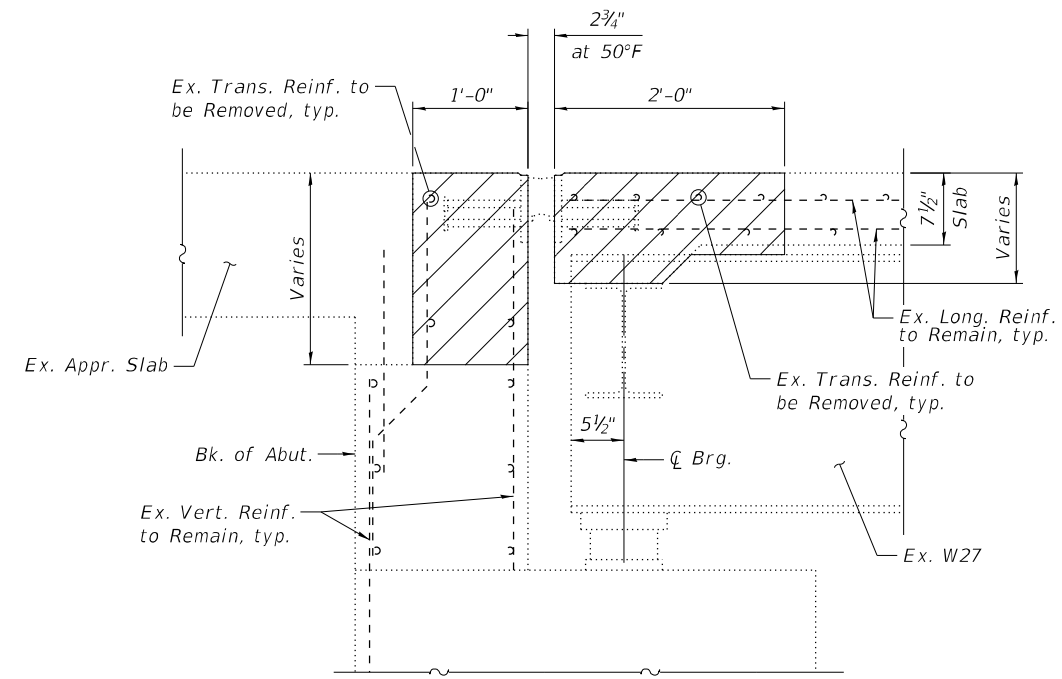

SECTION C-C

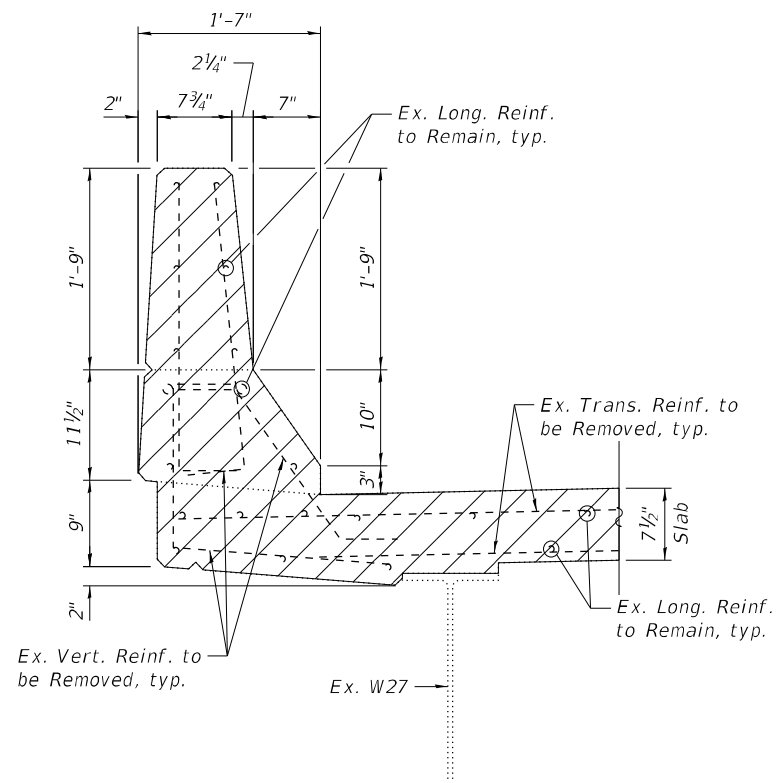

SECTION B-B

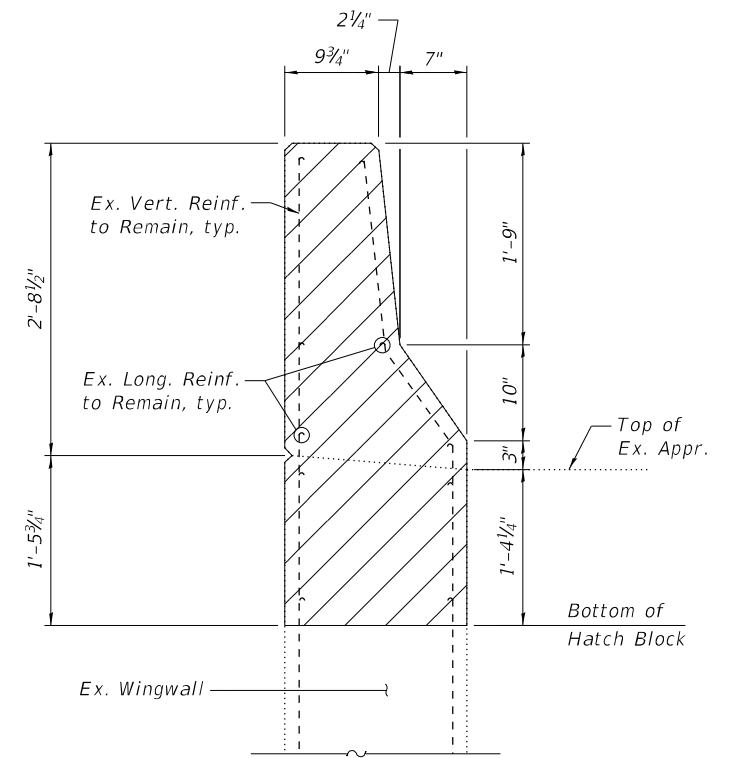

SECTION A-A

LEGEND



Notes:  
See Sheet 7 of 14 for section locations,  
bar details and bill of material.  
See Sheet 9 of 14 for joint seal details.

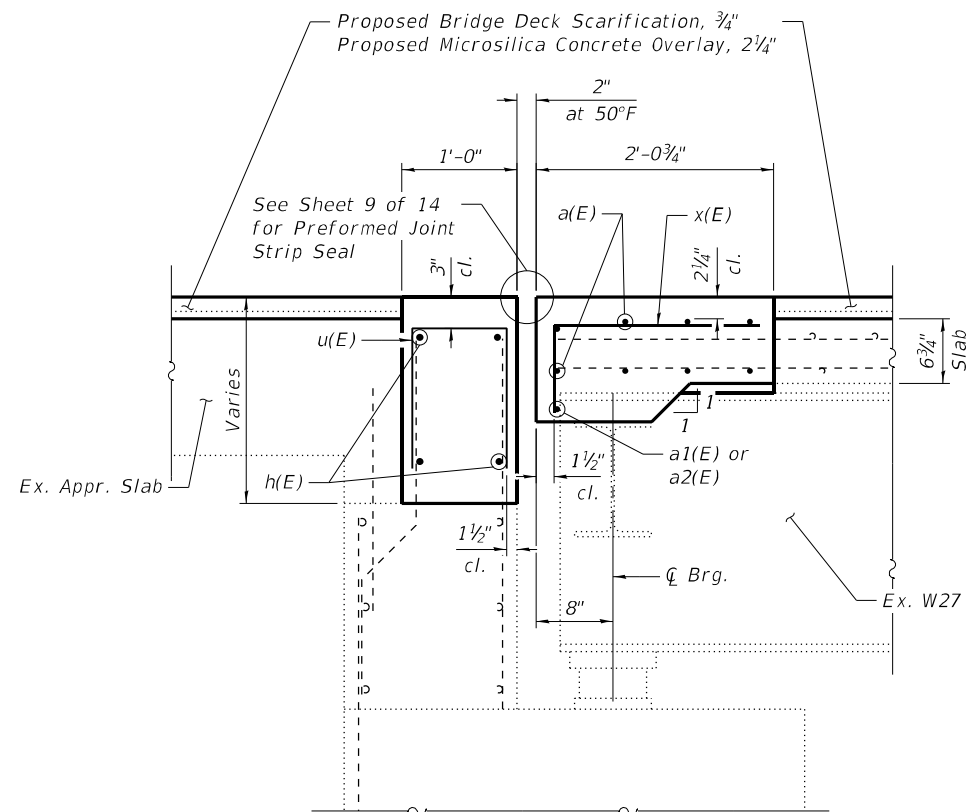

SECTION F-F

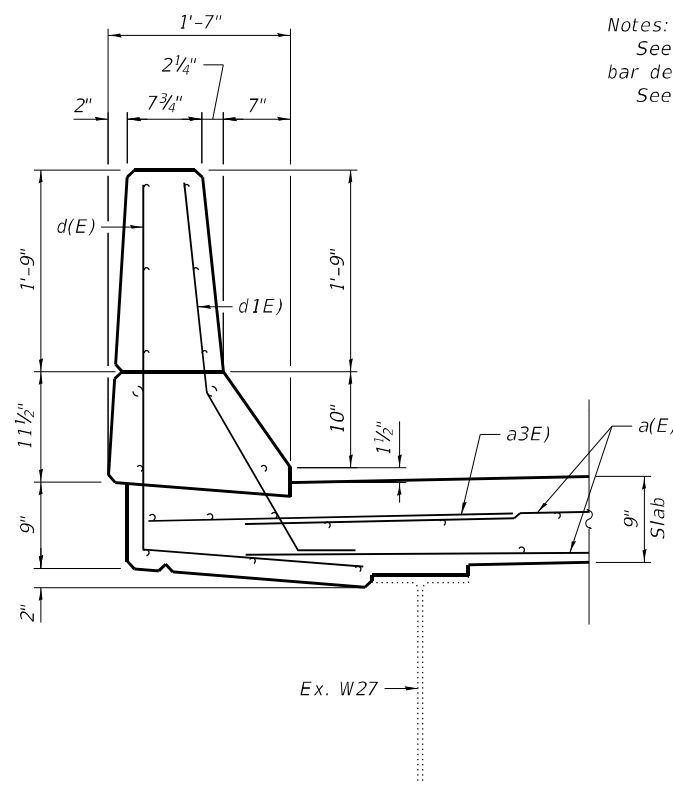

SECTION E-E

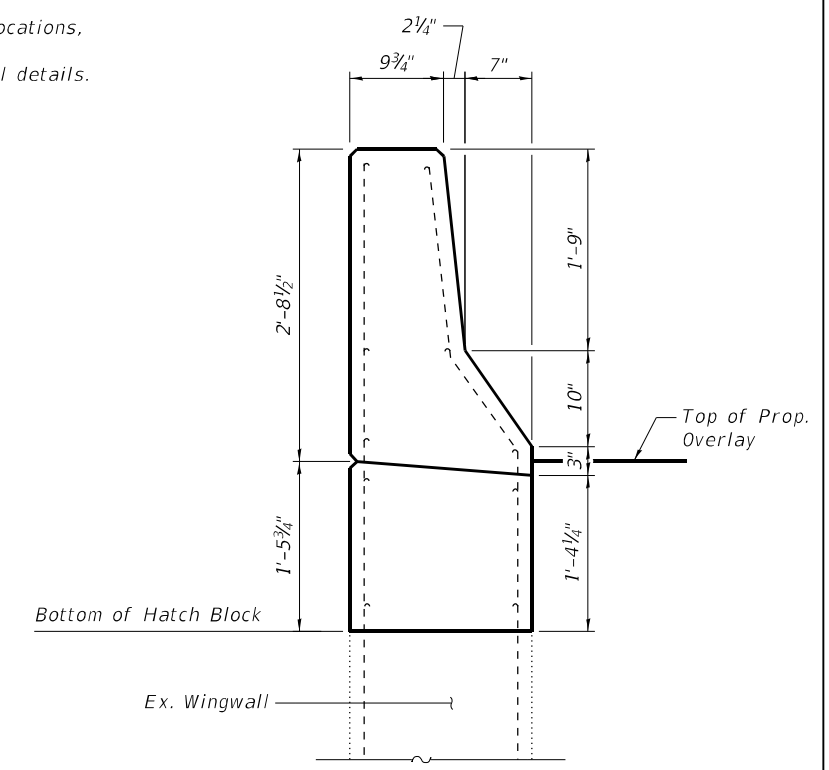

SECTION D-D

MODEL: SMODELNAMES  
FILE NAME: \$FILES



QUIGG ENGINEERING INC

USER NAME = \$USER\$	DESIGNED - CFS	REVISED -
\$FILES\$	CHECKED - RPW	REVISED -
PLOT SCALE = \$SCALE\$	DRAWN - CFS	REVISED -
PLOT DATE =	CHECKED - MDC	REVISED -

STATE OF ILLINOIS  
DEPARTMENT OF TRANSPORTATION

EXPANSION JOINT DETAILS  
STRUCTURE NO. 029-0012

SHEET 8 OF 14 SHEETS

F.A.P. RTE.	SECTION	COUNTY	TOTAL SHEETS	SHEET NO.
315	(139,138)(BC,BC-1)BR,BR-1)BR	FULTON	119	70
CONTRACT NO. 68H20				
ILLINOIS FED. AID PROJECT				

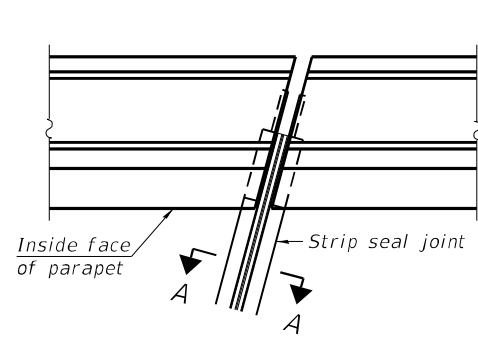

FOR SKEWS  $\leq 30^\circ$

PLAN AT PARAPET

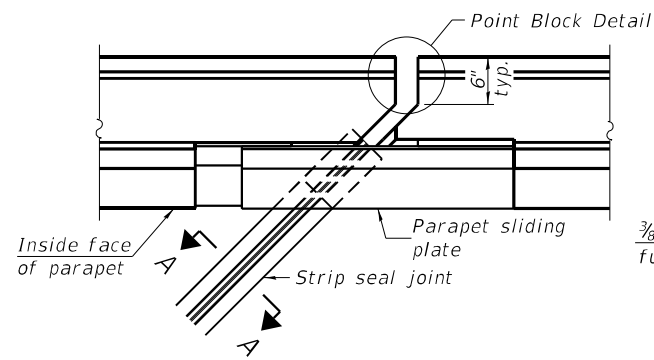

FOR SKEWS  $> 30^\circ$

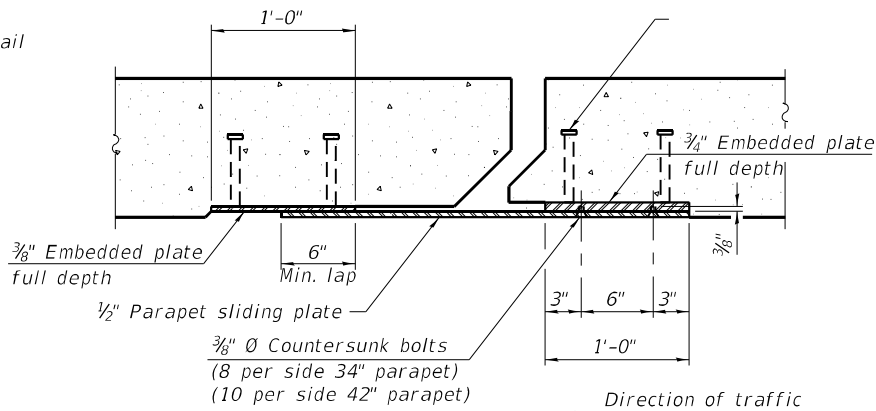

SECTION B-B

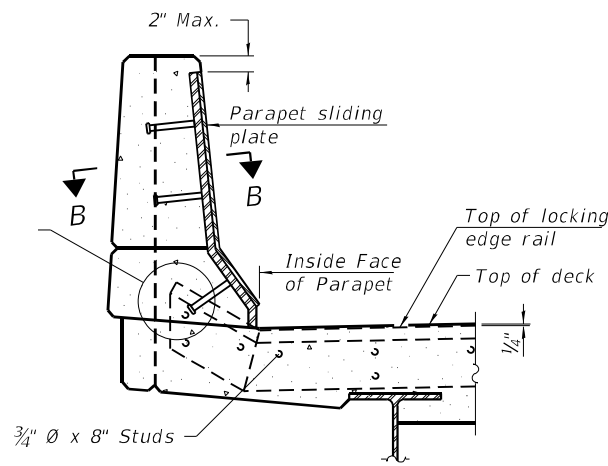

ELEVATION AT PARAPET

(Skews  $> 30^\circ$  shown. Skews  $\leq 30^\circ$  similar except as shown in plan view.)

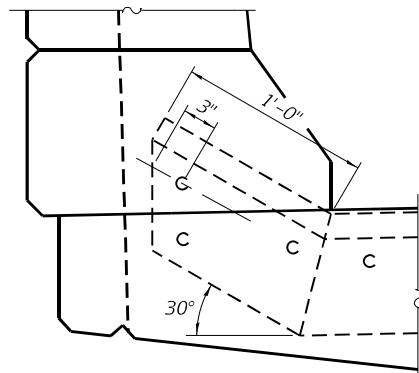

DETAIL A

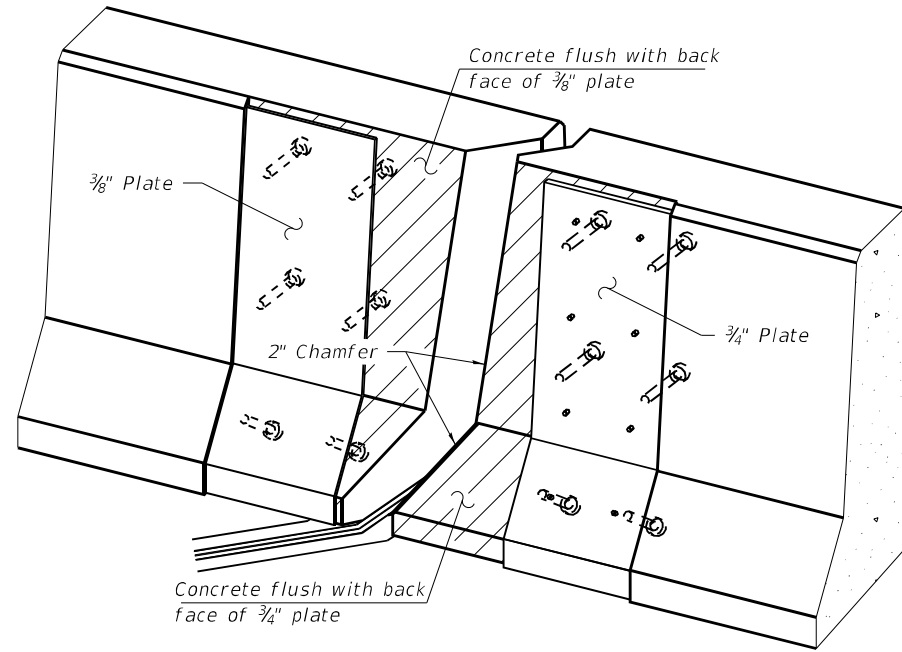

TRIMETRIC VIEW  
(Showing embedded plates only)

Notes:

The strip seal shall be made continuous and shall have a minimum thickness of  $\frac{1}{4}$ ". The configuration of the strip seal shall match the configuration of the locking edge rails. Open or "webbed" strip seal gland configurations are not permitted. The gland shall be sized for a maximum rated movement of 4 inches.

The locking edge rails depicted are configured for typical applications and are conceptual only. The actual configuration of the locking edge rails and matching strip seal may vary from manufacturer to manufacturer provided they fit the application and meet the minimum anchorage shown. Flanged edge rails, however, will not be allowed.

The manufacturer's recommended installation methods shall be followed.

All steel components shall be galvanized after fabrication according to Article 520.03 of the Standard Specifications.

The Maximum space between locking edge rail segments shall be  $\frac{3}{16}$ " and sealed with a suitable sealant; however, any rail joint within 10' measured perpendicular to the face of the curb or parapet shall be welded as shown in the locking edge rail splice detail.

Cost of parapet sliding plates, embedded plates, and anchorage studs included with Preformed Joint Strip Seal. 34" F-shape barrier shown, 42" F-shape similar as noted.

The concrete opening below the strip seal will vary based on the locking edge rail chosen by the Contractor. Deck and parapet lengths shown elsewhere in the plans are dimensioned to the concrete opening, not the joint opening, and are based on the rolled locking edge rail. If the Contractor elects to use a different locking edge rail, dimensional adjustments may be required. One exception to this would be the strip seal joint at the end of the precast bridge approach slab. For these cases the pavement connector length shall be adjusted, not the length of the bridge approach slab.

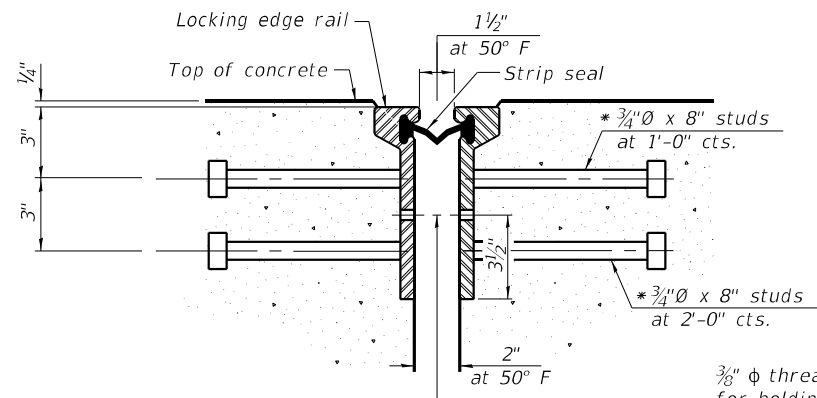

SHOWING ROLLED RAIL JOINT

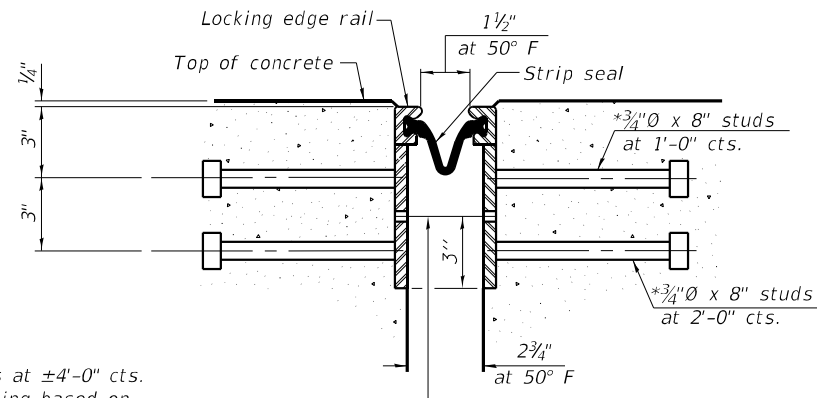

SHOWING WELDED RAIL JOINT

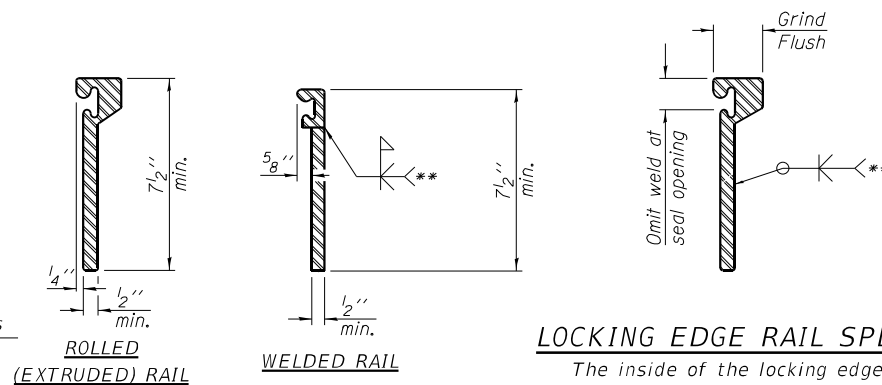

LOCKING EDGE RAIL SPLICE

The inside of the locking edge rail groove shall be free of weld residue. Rolled rail shown, welded rail similar.

$\frac{3}{8}$ "  $\phi$  threaded rods in  $\frac{1}{16}$ "  $\phi$  holes at  $\pm 4'-0"$  cts. for holding the proper joint opening based on the temperature during the deck pour. Place to miss studs. All rods shall be burned, or sawed off flush with the plates after concrete is set.

SECTION A-A

\* Granular or solid flux filled headed studs conforming to Article 1006.32 of the Std. Specs., automatically end welded.

EJ-SS (TALL WITH GUTTER) 10-1-19

MODEL: SMODELNAMES  
FILE NAME: \$FILES



USER NAME = \$USERS\$	DESIGNED - CFS	REVISED -
\$FILESS\$	CHECKED - RPW	REVISED -
PLOT SCALE = \$SCALE\$	DRAWN - CFS	REVISED -
PLOT DATE =	CHECKED - MDC	REVISED -

STATE OF ILLINOIS  
DEPARTMENT OF TRANSPORTATION

PREFORMED JOINT STRIP SEAL  
STRUCTURE NO. 029-0012

SHEET 9 OF 14 SHEETS

F.A.P. RTE.	SECTION	COUNTY	TOTAL SHEETS	SHEET NO.
315	(139,138)(BC,BC-1)BR,BR-1)BRR	FULTON	119	71
			CONTRACT NO. 68H20	
		ILLINOIS FED. AID PROJECT		

BILL OF MATERIAL

Item	Unit	Total
Preformed Joint Strip Seal	Foot	76

SDATE\$ STIME\$

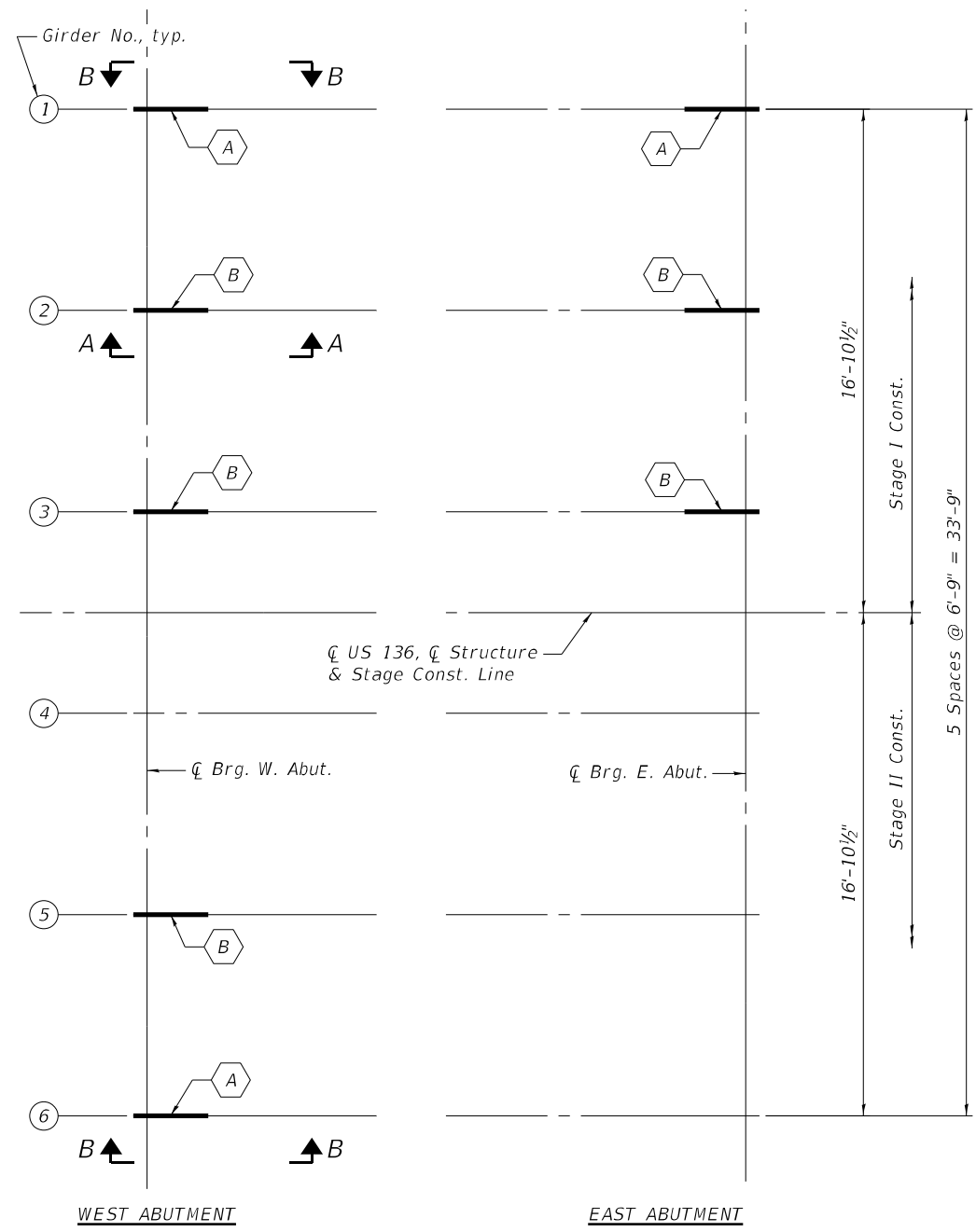

**PARTIAL FRAMING PLAN**

(A) - Girder End Repair "A"  
 (B) - Girder End Repair "B"

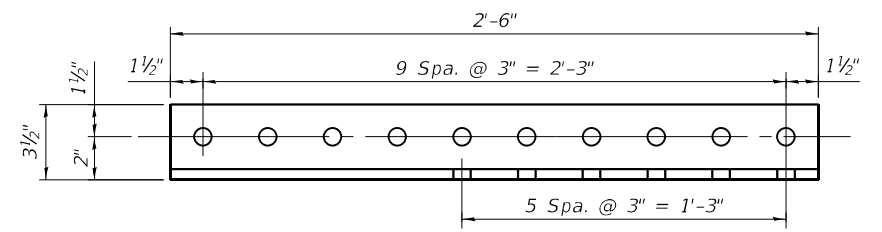

**PLATE A**  
(13 required)

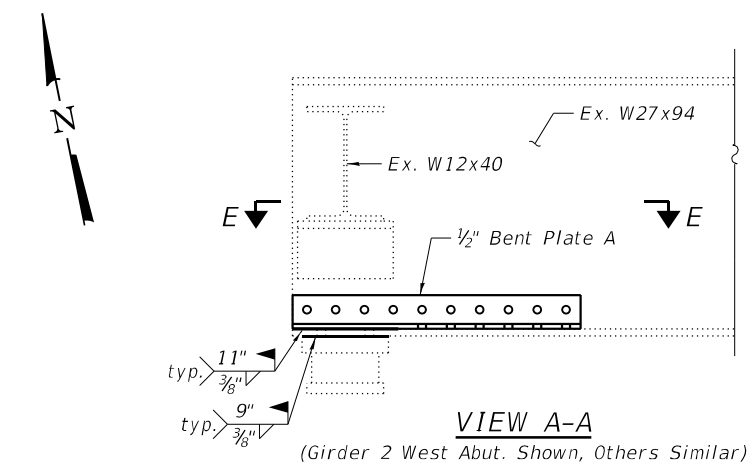

**VIEW A-A**  
(Girder 2 West Abut. Shown, Others Similar)

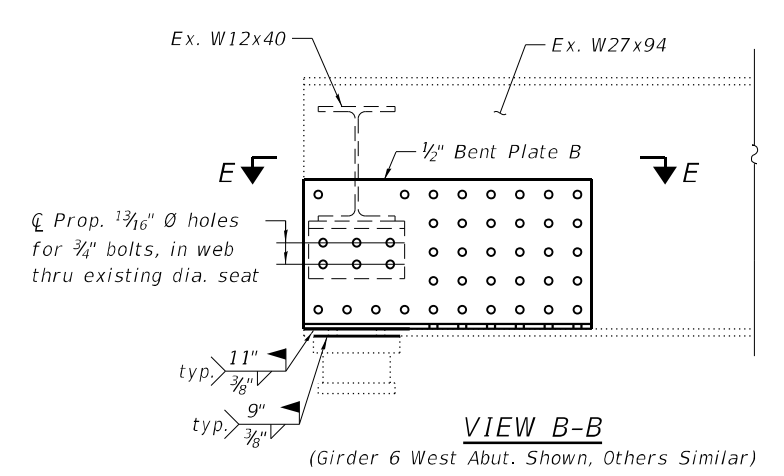

**VIEW B-B**  
(Girder 6 West Abut. Shown, Others Similar)

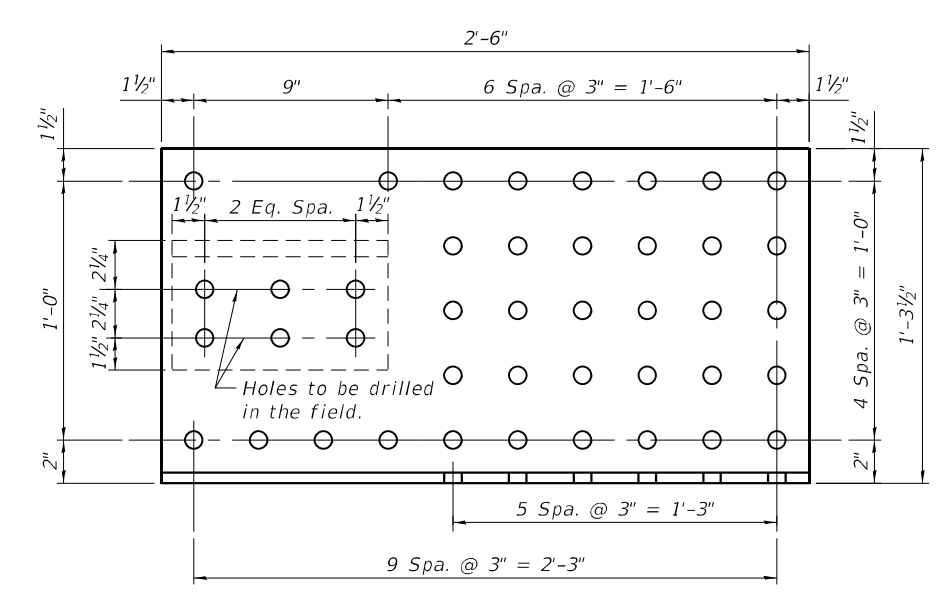
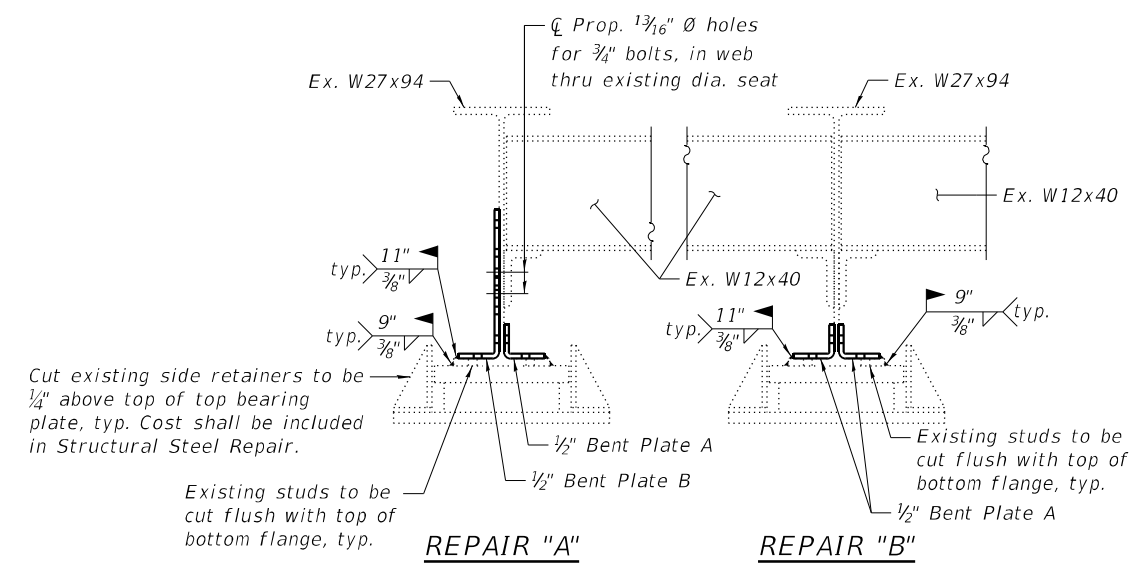

**PLATE B**  
(3 required)

**Notes:**

All structural steel shall be AASHTO M270 Grade 50, unless otherwise noted.

All repair materials including structural steel plates, bolts, nuts, and washers shall be galvanized per the special provision "Hot Dip Galvanizing for Structural Steel". Cost included in Structural Steel Repair.

Fasteners shall be ASTM A325 Type 1, mechanically galvanized bolts. Bolts 3/4" Ø, holes 1 3/16" Ø, unless otherwise noted.

Existing structural steel that will be in contact with new structural steel shall be cleaned and painted prior to erection as required by the special provision "Cleaning and Painting Contact Surface Areas of Existing Steel Structures".

Use holes in new steel as template to field drill holes in existing steel.

Plan dimensions and details relative to existing plans are subject to nominal construction variations. The Contractor shall field verify existing dimensions and details affecting new construction and make necessary approved adjustments prior to construction or ordering of materials. Such variations shall not be caused for additional compensation for change in scope of the work, however, the Contractor will be paid for the quantity actually furnished at the unit price bid for the work.

No field welding is permitted except as specified in the contract documents.

The cut area of the existing side retainers shall be cleaned and painted as required by the special provision "Cleaning and Painting Contact Surface Areas of Existing Steel Structures." Cost included with Structural Steel Repair.

**BILL OF MATERIAL**

Item	Unit	Total
Structural Steel Repair	Pound	860

MODEL: SMODELNAMES  
FILE NAME: \$FILES



USER NAME = \$USERS\$	DESIGNED - CFS	REVISED -
\$FILES\$	CHECKED - RPW	REVISED -
PLOT SCALE = \$SCALE\$	DRAWN - CFS	REVISED -
PLOT DATE =	CHECKED - MDC	REVISED -

**STATE OF ILLINOIS  
DEPARTMENT OF TRANSPORTATION**

**BEAM END REPAIRS  
STRUCTURE NO. 029-0012**

F.A.P. RTE.	SECTION	COUNTY	TOTAL SHEETS	SHEET NO.
315	[139,138(BC;BC-1)BR,BR-1]BR	FULTON	119	72
CONTRACT NO. 68H20				
ILLINOIS FED. AID PROJECT				



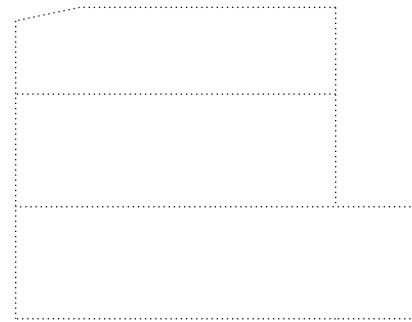

**SOUTHWEST WINGWALL**  
(Looking North)

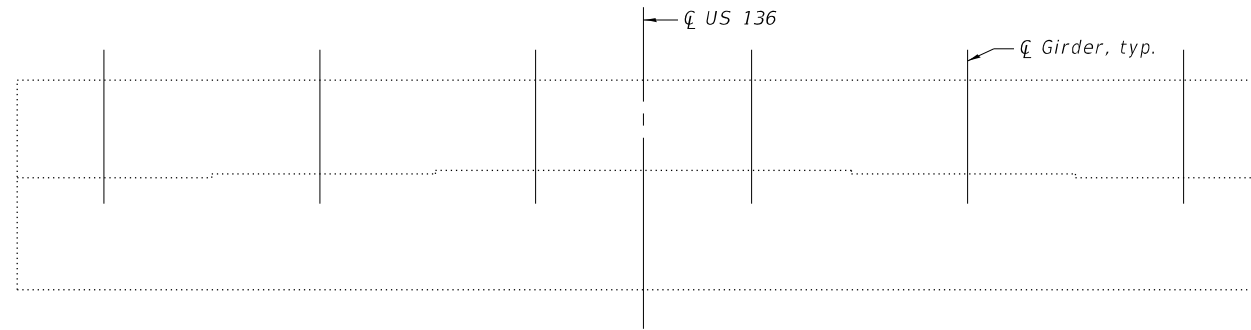

**WEST ABUTMENT**  
(Looking West)

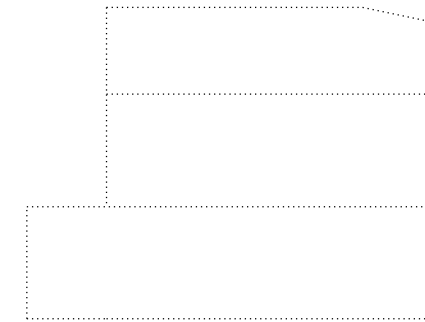

**NORTHWEST WINGWALL**  
(Looking South)

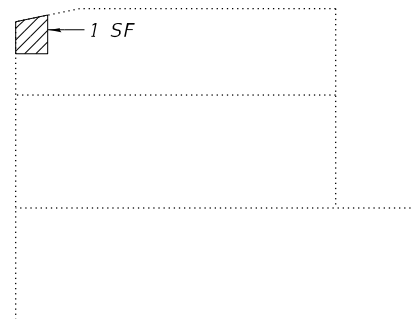

**NORTHEAST WINGWALL**  
(Looking South)

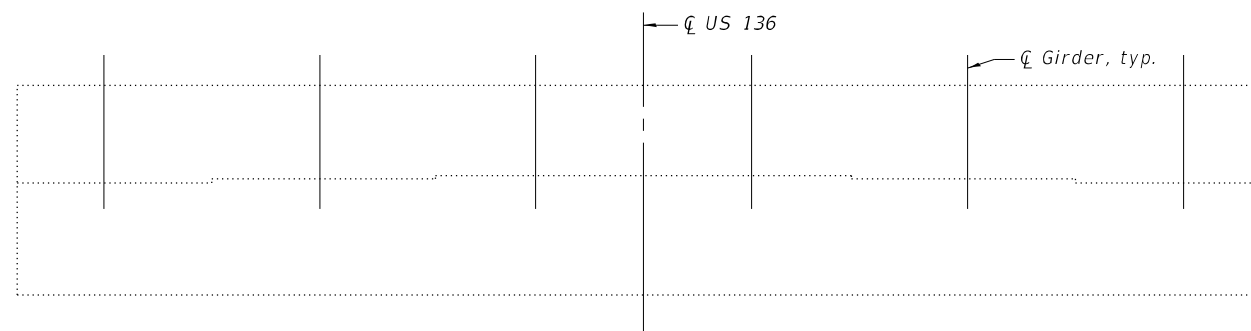

**EAST ABUTMENT**  
(Looking East)



**SOUTHEAST WINGWALL**  
(Looking North)

**LEGEND**

 Structural Repair of Concrete (Depth Equal to or less than 5")

**BILL OF MATERIAL**

Item	Unit	Total
Structural Repair of Concrete (Depth Equal to or less than 5")	Sq. Ft.	1

MODEL: \$MODELNAME\$  
FILE NAME: \$FILES



QUIGG ENGINEERING INC

USER NAME = \$USER\$	DESIGNED - CFS	REVISED -
\$FILE\$	CHECKED - RPW	REVISED -
PLOT SCALE = \$SCALE\$	DRAWN - CFS	REVISED -
PLOT DATE =	CHECKED - MDC	REVISED -

**STATE OF ILLINOIS  
DEPARTMENT OF TRANSPORTATION**

**ABUTMENT REPAIRS  
STRUCTURE NO. 029-0012**

SHEET 11 OF 14 SHEETS

F.A.P. RTE.	SECTION	COUNTY	TOTAL SHEETS	SHEET NO.
315	[139,138(BC;BC-1)BR,BR-1]BRR	FULTON	119	73
CONTRACT NO. 68H20				
ILLINOIS		FED. AID PROJECT		

SDATE\$ \$TIME\$

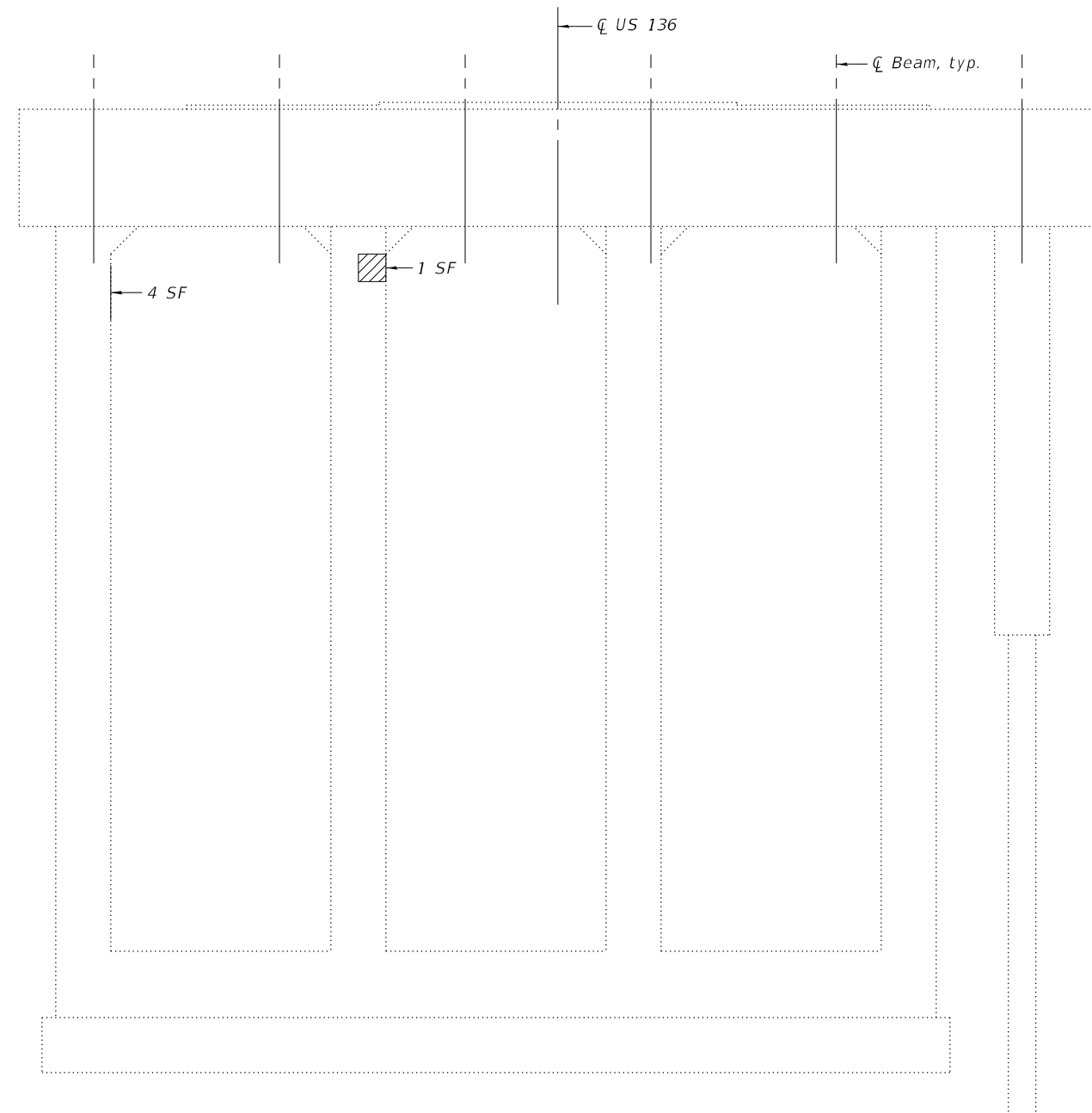

**PIER 1 WEST FACE**  
(Looking East)

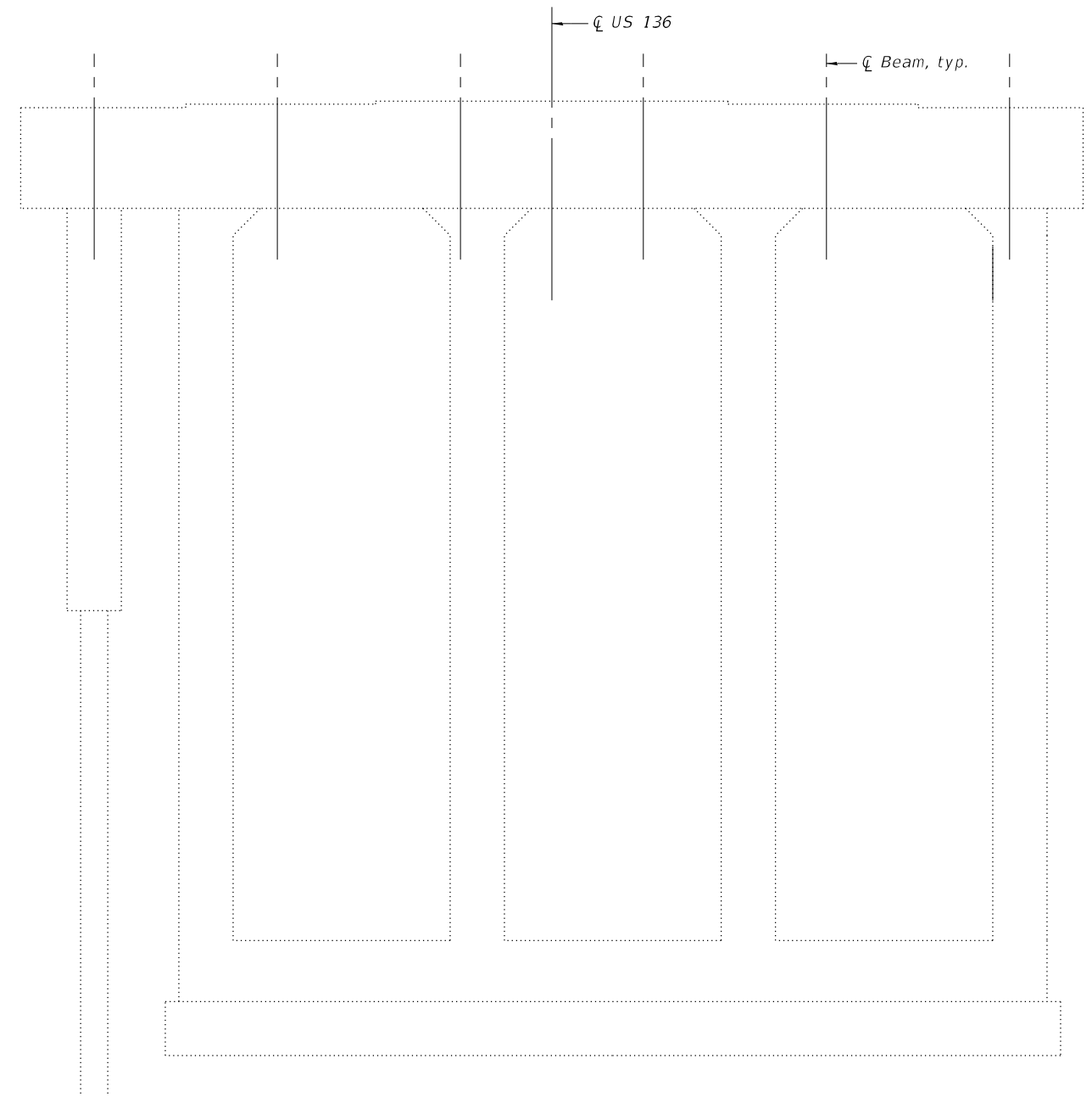

**PIER 1 EAST FACE**  
(Looking West)

**LEGEND**

 Structural Repair of Concrete (Depth Equal to or less than 5")

**BILL OF MATERIAL**

Item	Unit	Total
Structural Repair of Concrete (Depth Equal to or less than 5")	Sq. Ft.	5

MODEL: \$MODELNAME\$  
FILE NAME: \$FILEL\$



QUIGG ENGINEERING INC

USER NAME = \$USER\$	DESIGNED - CFS	REVISED -
\$FILEL\$	CHECKED - RPW	REVISED -
PLOT SCALE = \$SCALE\$	DRAWN - CFS	REVISED -
PLOT DATE =	CHECKED - MDC	REVISED -

**STATE OF ILLINOIS**  
**DEPARTMENT OF TRANSPORTATION**

**PIER 1 REPAIRS**  
**STRUCTURE NO. 029-0012**

SHEET 12 OF 14 SHEETS

F.A.P. RTE.	SECTION	COUNTY	TOTAL SHEETS	SHEET NO.
315	[139,138(BC;BC-1)BR,BR-1]BRR	FULTON	119	74
			CONTRACT NO. 68H20	
		ILLINOIS	FED. AID PROJECT	

\$DATE\$ \$TIME\$

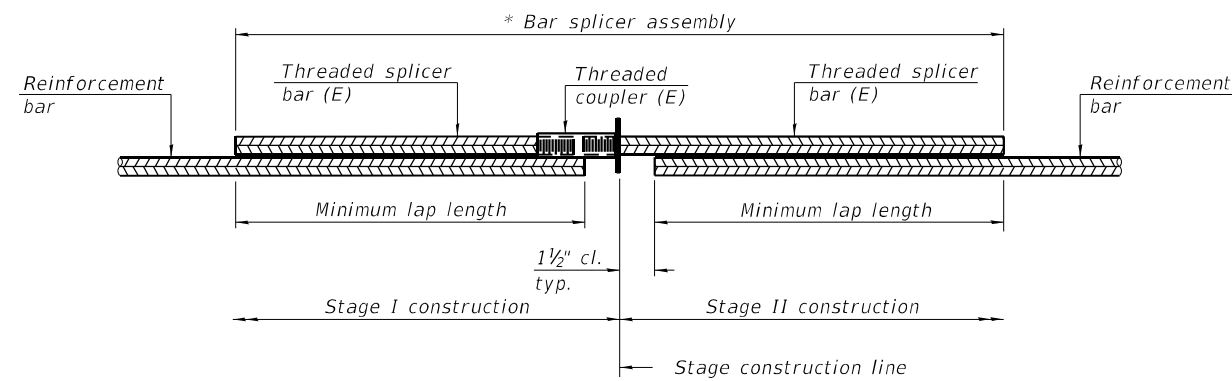

**STANDARD BAR SPLICER ASSEMBLY PLAN**

Only bar splicer assemblies as presented on the approved QPL list may be used.

Threaded splicer bar length = min. lap length + 1 1/2" + thread length

\* Epoxy not required on Bar Splicer Assembly components used in conjunction with black bars.

Location	Bar size	No. assemblies required	Minimum lap length
Bridge Deck Side of Exp. Joint	#5	18	3'-4"
Appr. Side of Exp. Joint	#6	8	4'-0"

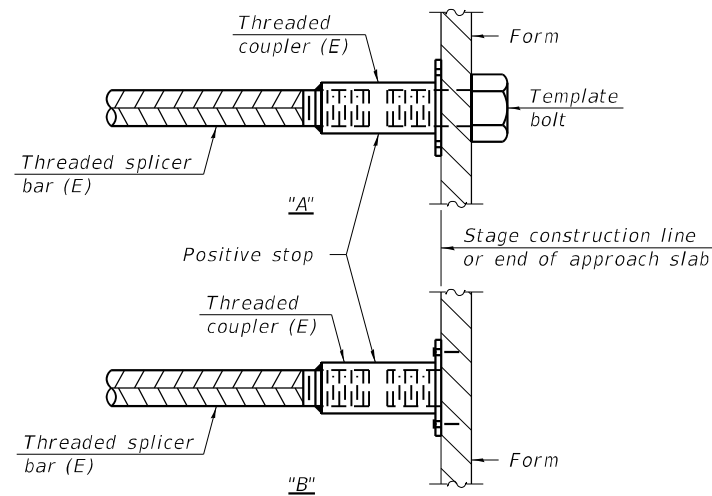

**INSTALLATION AND SETTING METHODS**

"A" : Set bar splicer assembly by means of a template bolt.

"B" : Set bar splicer assembly by nailing to wood forms or cementing to steel forms.

(E) : Indicates epoxy coating.

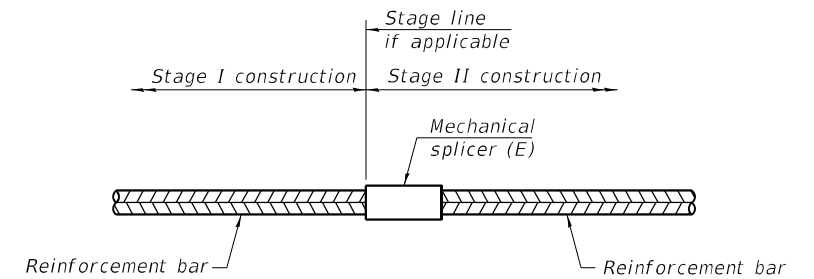

**STANDARD MECHANICAL SPLICER**

Location	Bar size	No. assemblies required

**Notes:**

Splicer bars shall be deformed with threaded ends and have a minimum 60 ksi yield strength.

All reinforcement shall be lapped and tied to the splicer bars.

Bar splicer assemblies shall be epoxy coated according to the requirements for reinforcement bars. See Section 508 of the Standard Specifications.

See approved list of bar splicer assemblies and mechanical splicers for alternatives.

MODEL: \$MODELNAME\$  
FILE NAME: \$FILES\$

BSD-1

2-1-2023



USER NAME = \$USERS\$	DESIGNED - CFS	REVISED -
\$FILESS\$	CHECKED - RPW	REVISED -
PLOT SCALE = \$SCALE\$	DRAWN - CFS	REVISED -
PLOT DATE =	CHECKED - MDC	REVISED -

STATE OF ILLINOIS  
DEPARTMENT OF TRANSPORTATION

BAR SPLICER ASSEMBLY AND MECHANICAL SPLICER DETAILS  
STRUCTURE NO. 029-0012

SHEET 13 OF 14 SHEETS

F.A.P. RTE.	SECTION	COUNTY	TOTAL SHEETS	SHEET NO.
315	[139,138(BC;BC-1)BR,BR-1]BRR	FULTON	119	75
CONTRACT NO. 68H20				
ILLINOIS FED. AID PROJECT				

\$DATE\$ \$TIME\$

STATE OF ILLINOIS  
DEPARTMENT OF TRANSPORTATION

DATE	BY	CHKD	APP'D	SHEET NO. 10
1/4/93	NJS			21 SHEETS

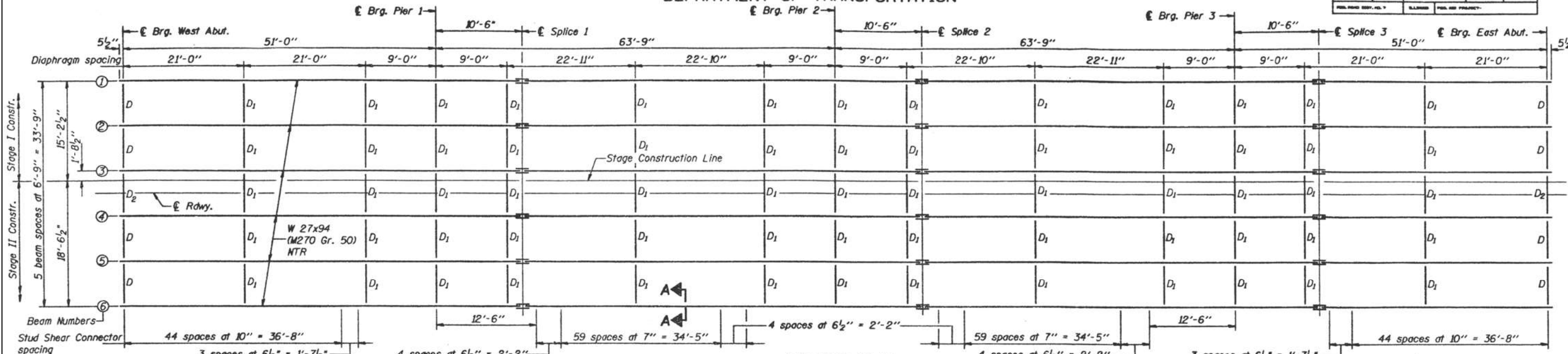

FRAMING PLAN

	0.4 Span 1 or 0.6 Span 4	Piers 1 & 3	0.5 Span 2 & 3	Pier 2
Is (in <sup>4</sup> )	3270	3270	3270	3270
Ic (in <sup>4</sup> )	9747	9747	9747	9747
Ss (in <sup>3</sup> )	243	243	243	243
Sc (in <sup>3</sup> )	375	375	375	375
Z (in <sup>3</sup> )	278	278	278	278
M <sub>P</sub> (K)	146.7	332.8	127.4	332.1
s <sub>P</sub> (K/ft.)	.287	.287	.287	.287
M <sub>sP</sub> (K)	65.1	69.9	69.9	69.9
M <sub>t</sub> (K)	350.9	196.9	392.8	208.9
M (Imp) (K)	98.8	53.8	104	55.4
S <sub>y</sub> (M <sub>t</sub> +I) (K)	749.5	417.8	828	440.5
M <sub>a</sub> (K)	1249.7	975.8	1332.9	1004.4
M <sub>u</sub> (K)	1158.3	1158.3	1158.3	1158.3
f <sub>sP</sub> non-comp (k.s.i.)	7.24	16.43	6.29	16.4
f <sub>sP</sub> (comp) (k.s.i.)	2.08	2.24	2.24	2.24
f <sub>s</sub> (k.s.i.)	24.0	20.63	26.5	21.75
f <sub>s</sub> (Overload) (k.s.i.)	33.3	37.1	35.0	38.1
f <sub>s</sub> (Total) (k.s.i.)	43.3	45.6	45.6	45.6
VR (K)	48.9	52.2	52.2	52.2

	Abuts.	Piers 1 & 3	Pier 2
R <sub>P</sub> (K)	21.0	67.0	66.5
R <sub>t</sub> (K)	35.2	42.0	43.3
Imp. (K)	9.9	11.5	11.5
R (Total) (K)	66.1	120.5	121.3

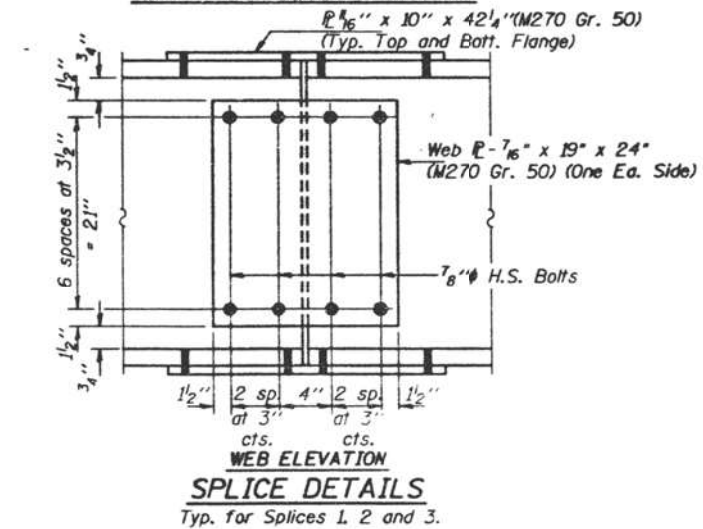
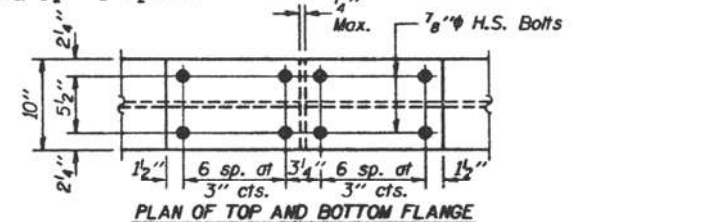

Notes: Two hardened washers shall be required over all bolt holes in diaphragms with the exception of the web splices on Diaphragm D<sub>2</sub>.  
The bolts for slotted holes in angles at beam 3 shall only be finger-tightened prior to the deck slab pouring and then be fully-tightened after completion of the pouring.  
All splice plate material and beams shall meet Notch Toughness Requirements. For top of beam elevations see sheet 11 of 21.

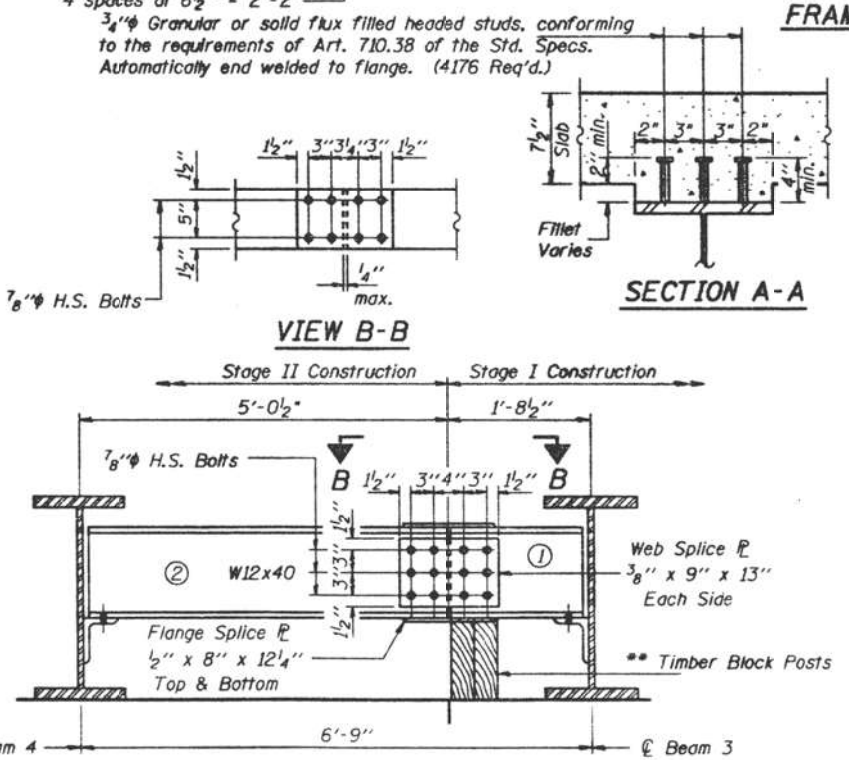
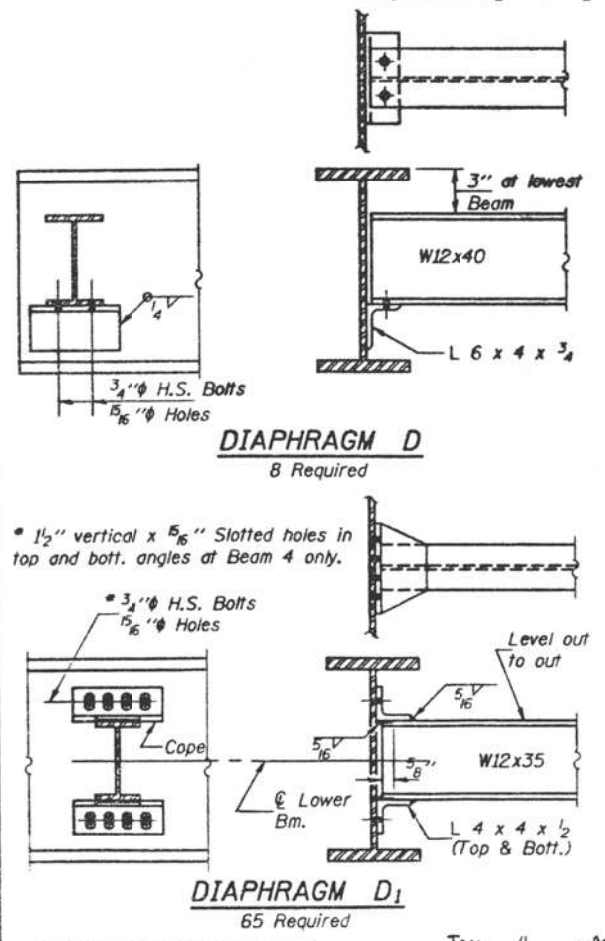

**DIAPHRAGM D<sub>2</sub> CONSTRUCTION SEQUENCE**

- 1.) Order Diaphragm D<sub>2</sub> in two sections with lengths of 4'-11<sup>3</sup>/<sub>4</sub>" and 1'-7<sup>3</sup>/<sub>4</sub>".
- 2.) Attach section ① of Diaphragm to Beam 3 and top flange splice P during Stage I Construction.
- 3.) Place Timber Block Posts between section ① of diaphragm and abutment bearing seat.
- 4.) Attach section ② of diaphragm to both Beam 4 and top flange splice P during Stage II Construction.
- 5.) Attach web splice plates to sections ① and ② of diaphragms.
- 6.) Remove Timber Block Posts.
- 7.) Attach bottom flange splice plate to sections ① and ② of diaphragms.

**FOR INFORMATION ONLY**

F.A. RT. 315 SEC. (139BC)BR-1  
FULTON COUNTY  
STATION 325+04.55

Existing Structure: SN 029-0055, originally built in 1989 as a four-span plate girder superstructure with stub abutments and solid wall piers. The back to back length = 390'-6" and the out to out width = 35'-2". Structure is to be repaired as detailed in these plans. Traffic is to be maintained using stage construction.

No salvage

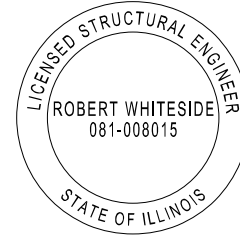

*Robert Whiteside* 12/14/2023  
 Robert Whiteside, Illinois S.E. 081-008015 Date  
 Expires 11/30/2024

**INDEX OF SHEETS**

1. General Plan and Elevation
2. General Data
3. Stage Construction Details
4. Temporary Concrete Barrier
5. Deck Overlay Plan
6. Drain Adjusting Details
7. Parapet Repairs
- 8-9. Expansion Joint Details
10. Preformed Joint Strip Seal
11. Beam End Repairs
12. Abutment Repairs
13. Bar Splicer Assembly and Mechanical Splicer Details
- 14-15. Existing Plans Reference Sheets

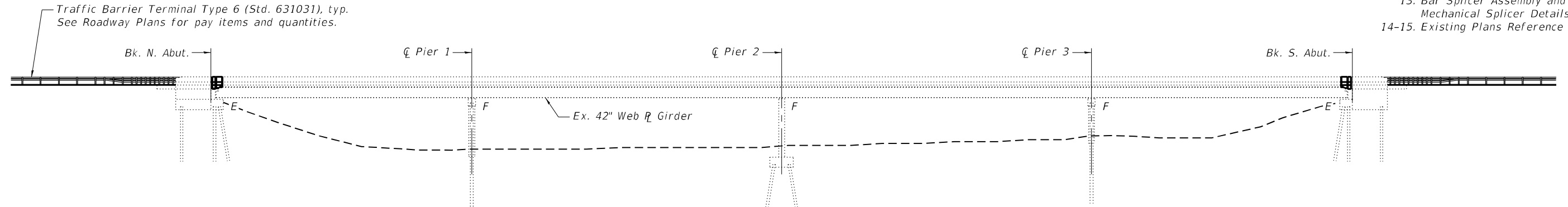

**ELEVATION**

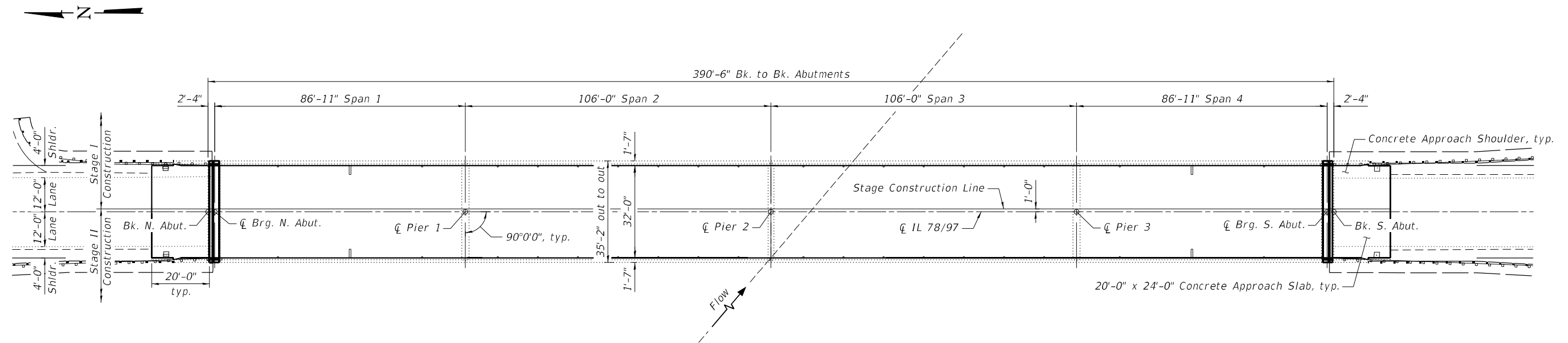

**PLAN**

**DESIGN STRESSES**

**FIELD UNITS (EXIST. CONST.)**

$f'_c = 3,500$  psi  
 $f_y = 60,000$  psi (Reinforcement)  
 $f_y = 50,000$  psi (M-223 Grade 50, Structural Steel)  
 $f_y = 36,000$  psi (M-183, Structural Steel)

**FIELD UNITS (NEW CONST.)**

$f'_c = 4,000$  psi  
 $f_y = 60,000$  psi (Reinforcement)  
 $f_y = 36,000$  psi (M270 Grade 36)  
 $f_y = 50,000$  psi (M270 Grade 50)

**LOADING HS20-44**

Existing and Proposed

**DESIGN SPECIFICATIONS**

2002 AASHTO Standard Specifications  
 for Highway Bridges - LFD

**SCOPE OF WORK**

1. Replace the transverse expansion joints.
2. Scarify the bridge deck and approach pavements.
3. Complete full depth deck repairs.
4. Place a microsilica concrete overlay.
5. Concrete repair of parapets.
6. Steel beam end repairs.
7. Concrete repair of abutments.

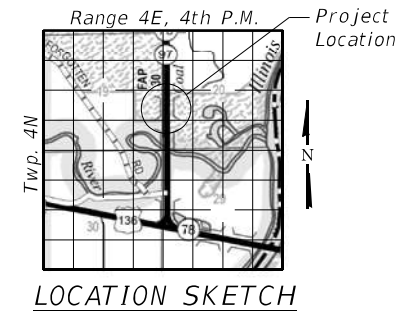

**LOCATION SKETCH**

**GENERAL PLAN AND ELEVATION**  
**IL 78/97 OVER SPOON RIVER OVERFLOW**  
**FAP ROUTE 30**  
**SECTION [139,138(BC;BC-1)BR,BR-1]BRR**  
**FULTON COUNTY**  
**STRUCTURE NO. 029-0055**

MODEL: \$MODELNAME\$  
 FILE NAME: \$FILES\$



USER NAME = \$USER\$	DESIGNED - ZLD	REVISED -
\$FILES\$	CHECKED - RPW	REVISED -
PLOT SCALE = \$SCALE\$	DRAWN - ZLD	REVISED -
PLOT DATE =	CHECKED - MDC	REVISED -

**STATE OF ILLINOIS**  
**DEPARTMENT OF TRANSPORTATION**

**GENERAL PLAN AND ELEVATION**  
**STRUCTURE NO. 029-0055**

SHEET 1 OF 15 SHEETS

F.A.P. RTE.	SECTION	COUNTY	TOTAL SHEETS	SHEET NO.
30	[139,138(BC;BC-1)BR,BR-1]BRR	FULTON	119	77
CONTRACT NO. 68H20				
ILLINOIS FED. AID PROJECT				

SDATE\$ STIME\$

**GENERAL NOTES**

Fasteners shall be ASTM A325 Type 1, mechanically galvanized bolts. Bolts 3/4" Ø, holes 13/16" Ø, unless otherwise noted.

Calculated weight of Structural Steel = 390 lbs (M270 Grade 50)

All structural steel shall be AASHTO M270 Grade 50, unless otherwise noted.

No field welding is permitted except as specified in the contract documents.

Reinforcement bars designated (E) shall be epoxy coated.

Plan dimensions and details relative to existing plans are subject to nominal construction variations. The Contractor shall field verify existing dimensions and details affecting new construction and make necessary approved adjustments prior to construction or ordering of materials. Such variations shall not be cause for additional compensation for a change in scope of the work, however, the Contractor will be paid for the quantity actually furnished at the unit price bid for the work.

Any reinforcement bars that are to remain that are damaged during concrete removal operations shall be repaired or replaced using an approved bar splicer or anchorage system. Cost included with Concrete Removal.

Existing longitudinal and vertical reinforcement bars remaining and extending into the removal areas shall be cleaned, straightened and incorporated into the new construction. Cost included with Concrete Removal.

Prior to pouring the new concrete deck, all heavy or loose rust, loose mill scale, and other loose or potentially detrimental foreign material shall be removed from the surfaces in contact with concrete. Tightly adhered paint may remain unless otherwise noted. Removal shall be accomplished by methods that will not damage the steel and the cost will be included in the pay item covering removal of the existing concrete.

The protective coat shall be applied to the new microsilica concrete overlay, new bridge deck concrete, and top and inside faces of the new portions of the parapets and wingwalls.

Joint openings shall be adjusted according to Article 520.04 of the Standard Specifications when the deck is poured at an ambient temperature other than 50°F.

All repair materials including structural steel plates, bolts, nuts and washers shall be galvanized per the special provision "Hot Dip Galvanizing for Structural Steel". Cost included in Structural Steel Repair.

**TOTAL BILL OF MATERIAL**

Item	Unit	Super	Sub	Total
Concrete Removal	Cu. Yd.	10.4	-	10.4
Concrete Superstructure	Cu. Yd.	11.4	-	11.4
Bridge Deck Grooving	Sq. Yd.	1,431	-	1,431
Protective Coat	Sq. Yd.	1,531	-	1,531
Reinforcement Bars, Epoxy Coated	Pound	1,600	-	1,600
Bar Splicers	Each	26	-	26
Preformed Joint Strip Seal	Foot	68	-	68
Inlets to be Adjusted	Each	4	-	4
Structural Steel Repair	Pound	390	-	390
Bridge Deck Scarification 3/4"	Sq. Yd.	1,504	-	1,504
Bridge Deck Microsilica Concrete Overlay 2 1/4"	Sq. Yd.	1,504	-	1,504
Structural Repair of Concrete (Depth Equal to or Less than 5 inches)	Sq. Ft.	10	55	65
Deck Slab Repair (Full Depth, Type I)	Sq. Yd.	2	-	2
Deck Slab Repair (Full Depth, Type II)	Sq. Yd.	4	-	4
Drainage Scuppers to be Adjusted	Each	4	-	4

MODEL: \$MODELNAME\$  
FILE NAME: \$FILES\$



QUIGG ENGINEERING INC

USER NAME = \$USER\$	DESIGNED - ZLD	REVISED -
\$FILE\$	CHECKED - RPW	REVISED -
PLOT SCALE = \$SCALE\$	DRAWN - ZLD	REVISED -
PLOT DATE =	CHECKED - MDC	REVISED -

**STATE OF ILLINOIS  
DEPARTMENT OF TRANSPORTATION**

**GENERAL DATA  
STRUCTURE NO. 029-0055**

SHEET 2 OF 15 SHEETS

F.A.P. RTE.	SECTION	COUNTY	TOTAL SHEETS	SHEET NO.
30	[139,138(BC;BC-1)BR,BR-1]BRR	FULTON	119	78
			CONTRACT NO. 68H20	
		ILLINOIS	FED. AID PROJECT	

SDATE\$ \$TIME\$

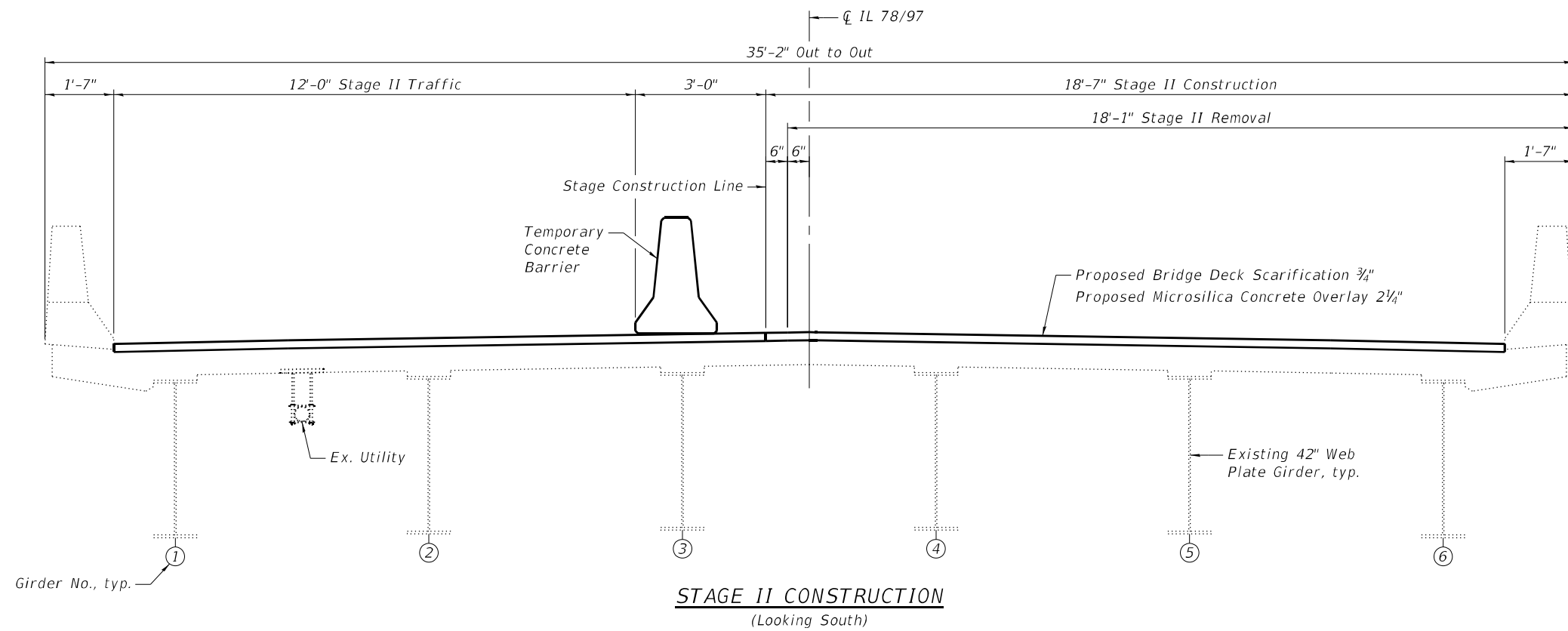
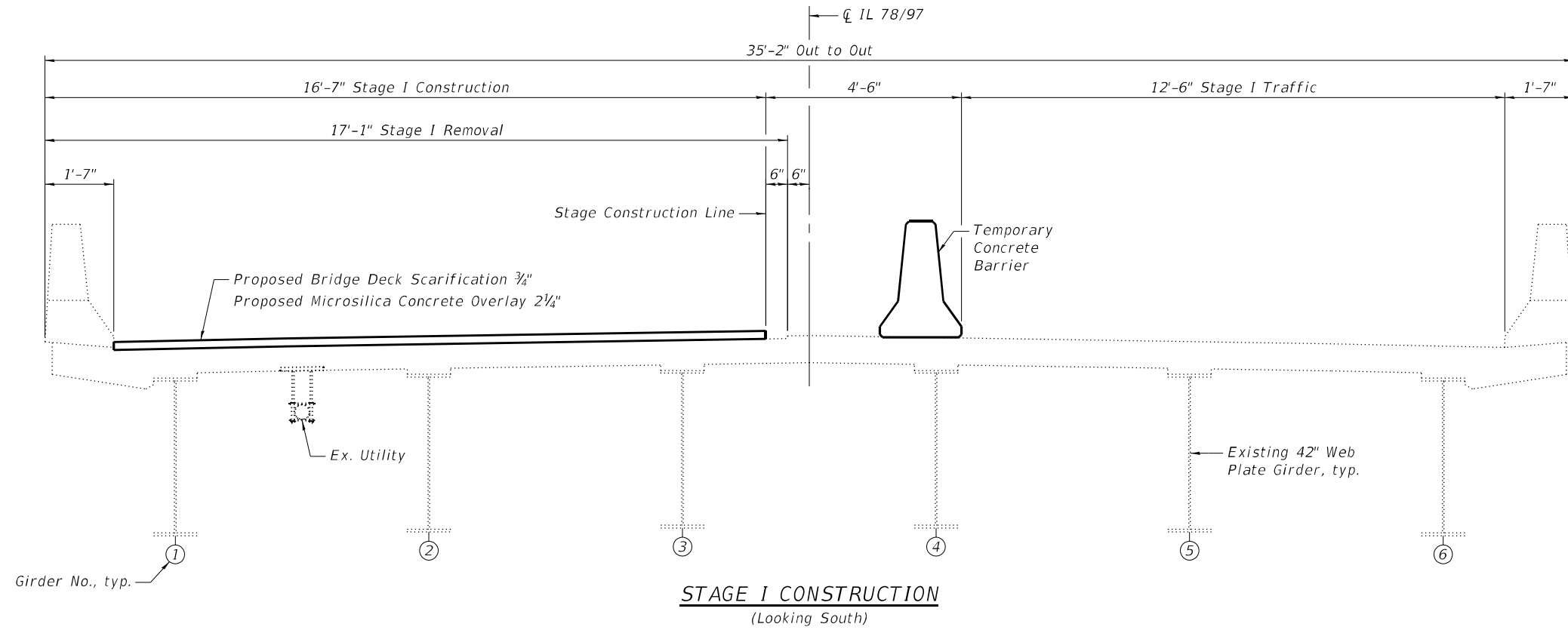

MODEL: \$MODELNAME\$  
FILE NAME: \$FILES



QUIGG ENGINEERING INC

USER NAME = \$USER\$	DESIGNED - ZLD	REVISED -
\$FILES\$	CHECKED - RPW	REVISED -
PLOT SCALE = \$SCALE\$	DRAWN - ZLD	REVISED -
PLOT DATE =	CHECKED - MDC	REVISED -

STATE OF ILLINOIS  
DEPARTMENT OF TRANSPORTATION

STAGE CONSTRUCTION DETAILS  
STRUCTURE NO. 029-0055

SHEET 3 OF 15 SHEETS

F.A.P. RTE.	SECTION	COUNTY	TOTAL SHEETS	SHEET NO.
30	[139,138(BC;BC-1)BR,BR-1]BRR	FULTON	119	79
CONTRACT NO. 68H20				
ILLINOIS FED. AID PROJECT				

\$DATE\$ \$TIME\$

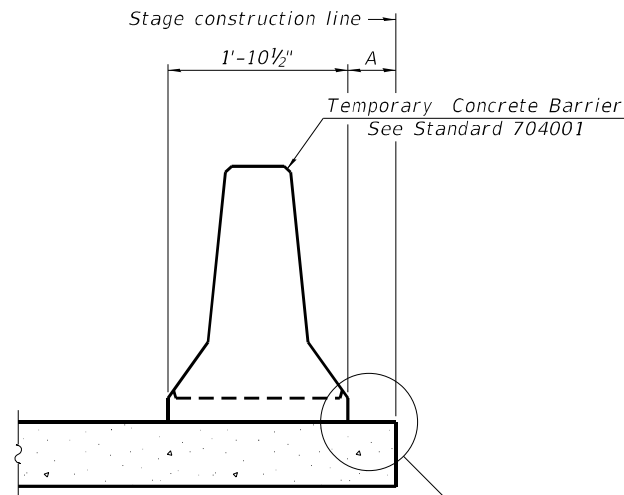

When "A" is 3'-1" or less, the temporary concrete barrier shall be restrained to the new slab according to Detail I, II or III. No restraint is required when "A" is greater than 3'-1".

NEW SLAB OR NEW DECK BEAM

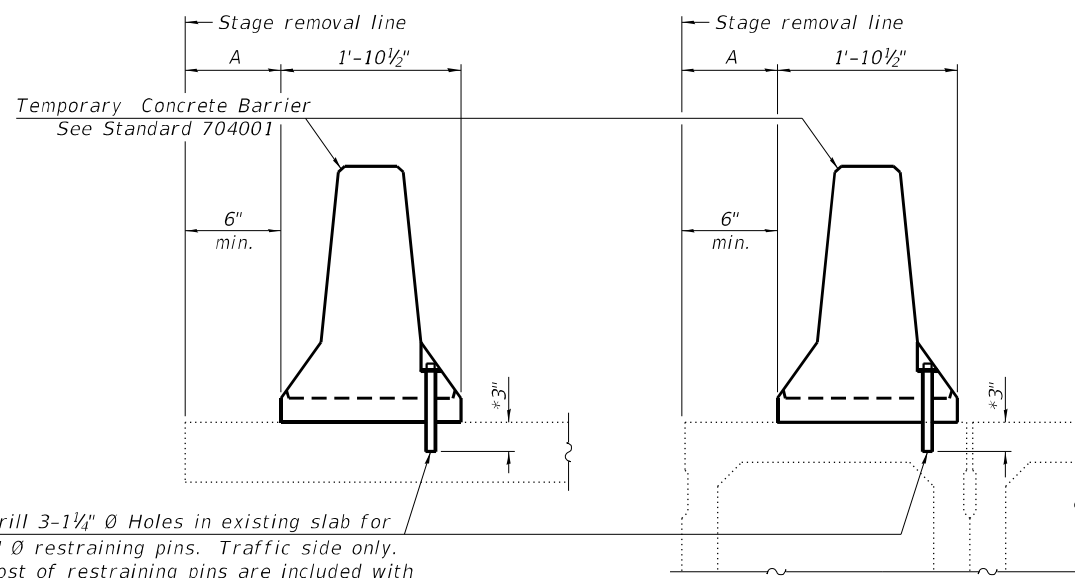

Drill 3-1/4" Ø Holes in existing slab for 1" Ø restraining pins. Traffic side only. Cost of restraining pins are included with Temporary Concrete Barrier. No restraint is required when "A" is greater than 3'-1".

EXISTING SLAB

\* When hot-mix asphalt wearing surface is present, embedment shall be 3" plus the wearing surface depth.

EXISTING DECK BEAM

SECTIONS THRU SLAB OR DECK BEAM

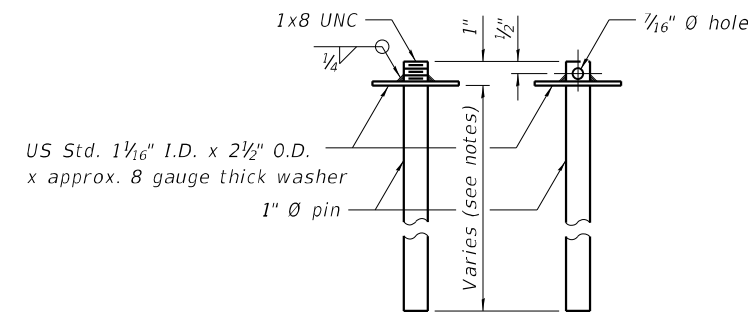

RESTRAINING PIN

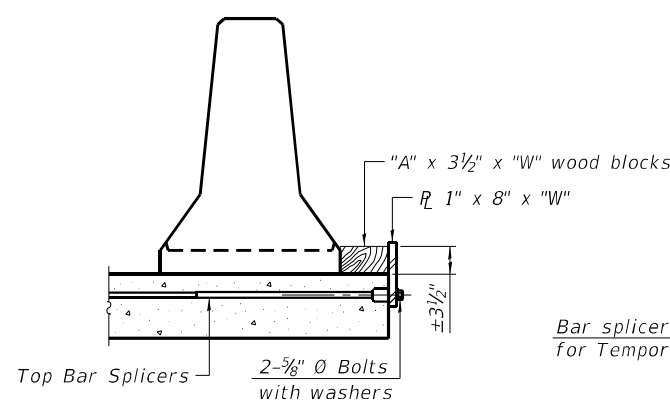

DETAIL I

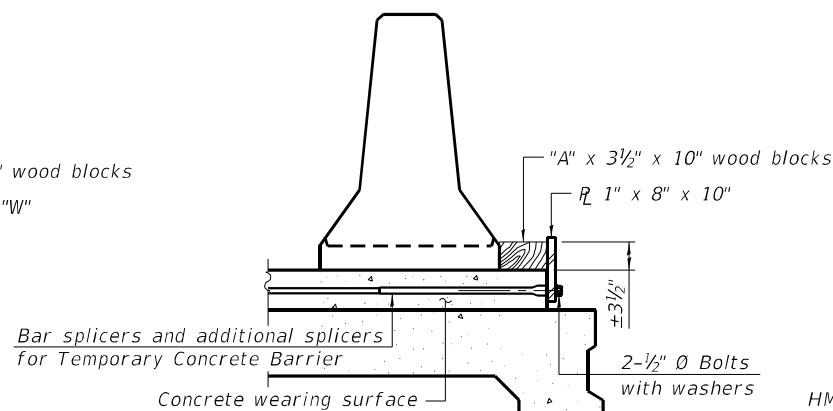

DETAIL II

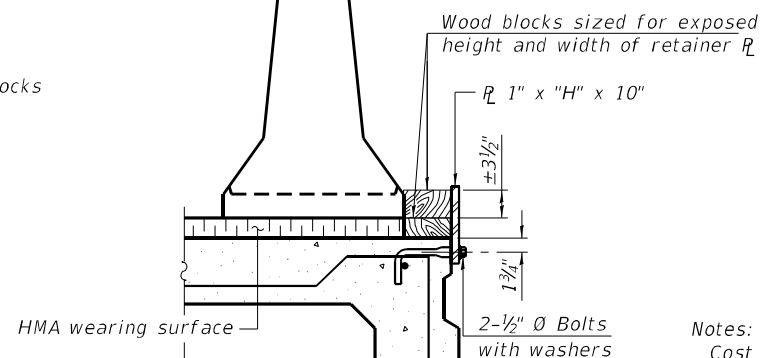

DETAIL III

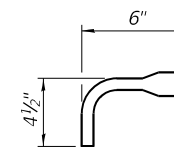

BAR SPLICER FOR #4 BAR - DETAIL III

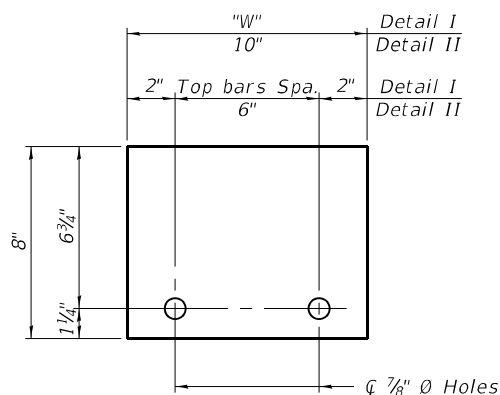

STEEL RETAINER R 1" x 8" x "W" (Detail I and II)

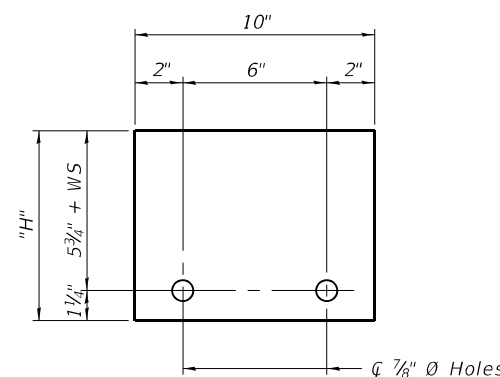

STEEL RETAINER R 1" x "H" x 10" (Detail III)

Notes:  
 Cost of retainer assembly is included with Temporary Concrete Barrier.  
 A retainer assembly shall be located at the approximate  $\frac{1}{2}$  of each temporary concrete barrier.  
 The retainer plate shall not be removed until the concrete on the adjacent stage is ready to be poured. For Detail III applications the retainer plate shall not be removed until just prior to placing the adjacent beam.  
 When the 'A' dimension is less than 1 1/2', the wood block shall be omitted and the barrier shall be placed in direct contact with the steel retainer plate. For deck beam applications the minimum required 'A' distance is 6" to accommodate the shear key clamping device.

- Detail I - Installation for a new bridge deck or bridge slab.
- Detail II - Installation for a new deck beam with an initial concrete wearing surface. Additional bar splicers shall be provided at 6'-0" centers and paired with the bar splicers of the concrete wearing surface reinforcement to accommodate the installation of the retainer assemblies. The cost of the additional bar splicers is included with the concrete wearing surface.
- Detail III - Installation for a new deck beam with no initial wearing surface or with an initial hot-mix asphalt (HMA) wearing surface present. The deck beam directly beneath the temporary concrete barrier shall be fabricated with bar splicer inserts in the side of the beam, as detailed, to accommodate the installation of the retainer assemblies. A pair of bar splicers, 6" apart, shall be placed at 6'-0" centers along the length of the beam. The cost of the bar splicers is included with the deck beam.

RAILING CRITERIA

NCHRP 350 Test Level	3
Railing Weight (plf)	440

R-27 10-12-2021

MODEL: \$MODELNAME\$  
 FILE NAME: \$FILES\$



QUIGG ENGINEERING INC

USER NAME = \$USERS\$	DESIGNED - ZLD	REVISED -
\$FILESS\$	CHECKED - RPW	REVISED -
PLOT SCALE = \$SCALE\$	DRAWN - ZLD	REVISED -
PLOT DATE =	CHECKED - MDC	REVISED -

STATE OF ILLINOIS  
 DEPARTMENT OF TRANSPORTATION

TEMPORARY CONCRETE BARRIER  
 STRUCTURE NO. 029-0055

SHEET 4 OF 15 SHEETS

F.A.P. RTE.	SECTION	COUNTY	TOTAL SHEETS	SHEET NO.
30	[139,138/BC/BC-1]BR, BR-1]BRR	FULTON	119	80
CONTRACT NO. 68H20				
ILLINOIS FED. AID PROJECT				



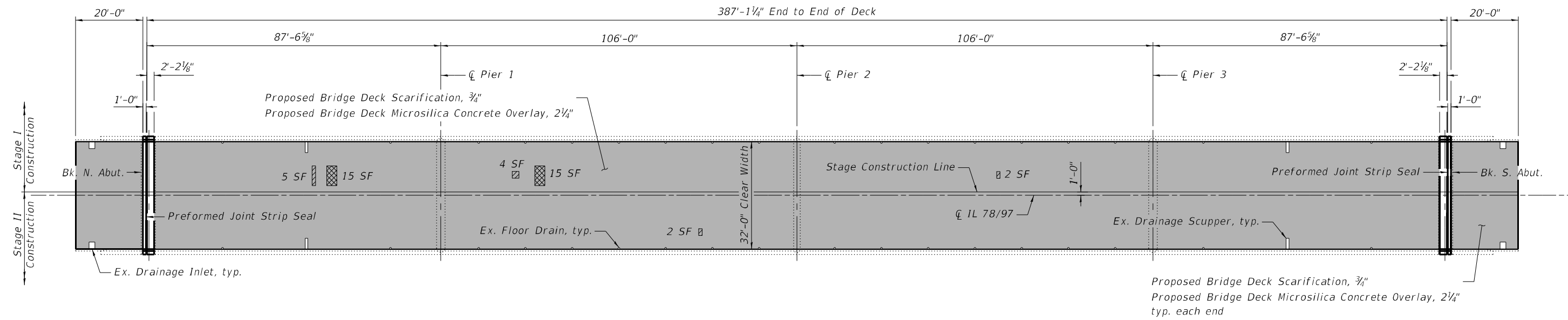
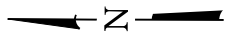

**PLAN**

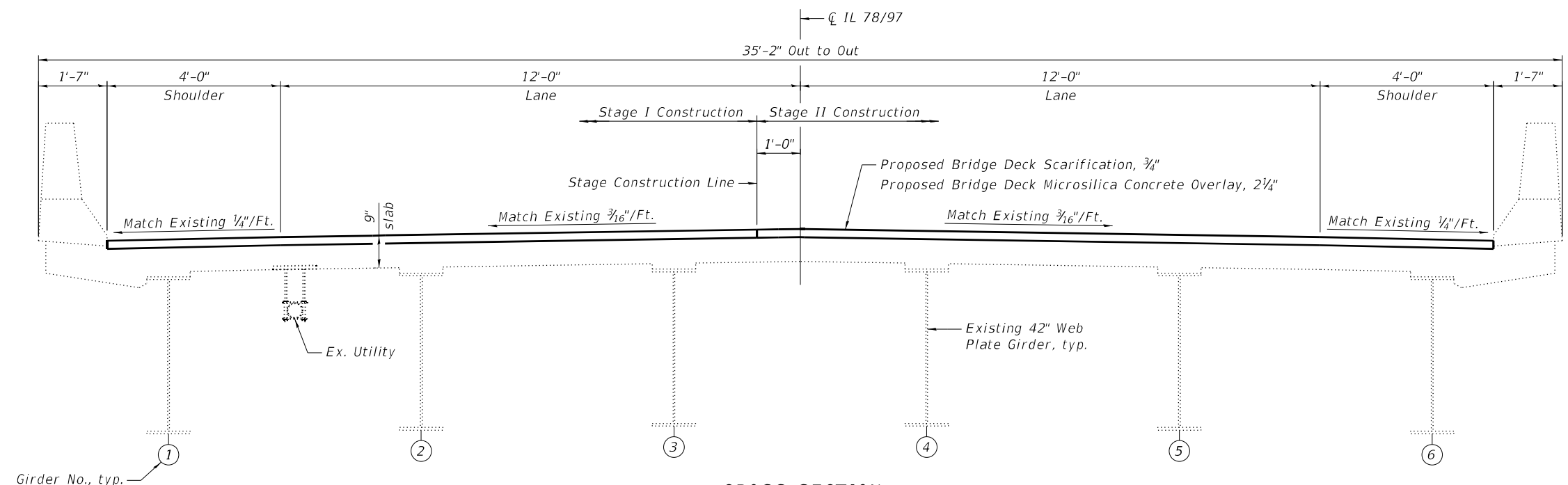

**CROSS SECTION**  
(Looking South)

**LEGEND**

- Deck Slab Repair (Full Depth, Type I)
- Deck Slab Repair (Full Depth, Type II)
- Scarification and Microsilica Concrete Overlay Limits

**Notes:**  
 See sheet 6 of 15 for overlay details at drainage scupper and drain pipes.  
 See sheets 8 thru 10 of 15 for expansion joint replacement details.  
 Deck Slab Repair (Full Depth, Type I) and Deck Slab Repair (Full Depth, Type II) areas are estimated and will be field verified by the Engineer prior to patching. The Engineer shall show actual locations of deck repairs on as-built plans.

**BILL OF MATERIAL**

Item	Unit	Total
Bridge Deck Grooving	Sq. Yd.	1,431
Protective Coat	Sq. Yd.	1,531
Bridge Deck Scarification 3/4"	Sq. Yd.	1,504
Bridge Deck Microsilica Concrete Overlay 2 1/4"	Sq. Yd.	1,504
Deck Slab Repair (Full Depth, Type I)	Sq. Yd.	2
Deck Slab Repair (Full Depth, Type II)	Sq. Yd.	4

MODEL: SMODELNAMES  
FILE NAME: \$FILES



USER NAME = \$USERS\$	DESIGNED - ZLD	REVISED -
\$FILES\$	CHECKED - RPW	REVISED -
PLOT SCALE = \$SCALE\$	DRAWN - ZLD	REVISED -
PLOT DATE =	CHECKED - MDC	REVISED -

**STATE OF ILLINOIS**  
**DEPARTMENT OF TRANSPORTATION**

**DECK OVERLAY PLAN**  
**STRUCTURE NO. 029-0055**

SHEET 5 OF 15 SHEETS

F.A.P. RTE. 30	SECTION [139,138(BC;BC-1)BR,BR-1]BRR	COUNTY FULTON	TOTAL SHEETS 119	SHEET NO. 81
CONTRACT NO. 68H20				
ILLINOIS FED. AID PROJECT				

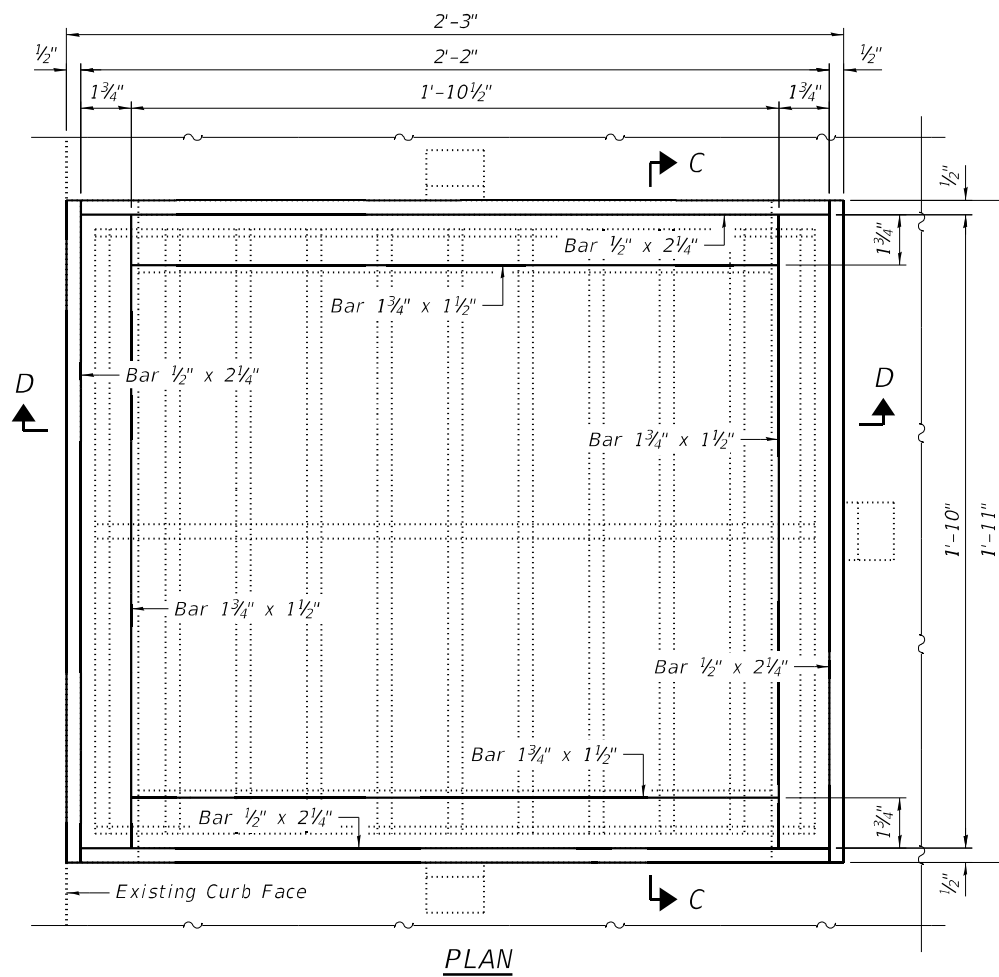

PLAN

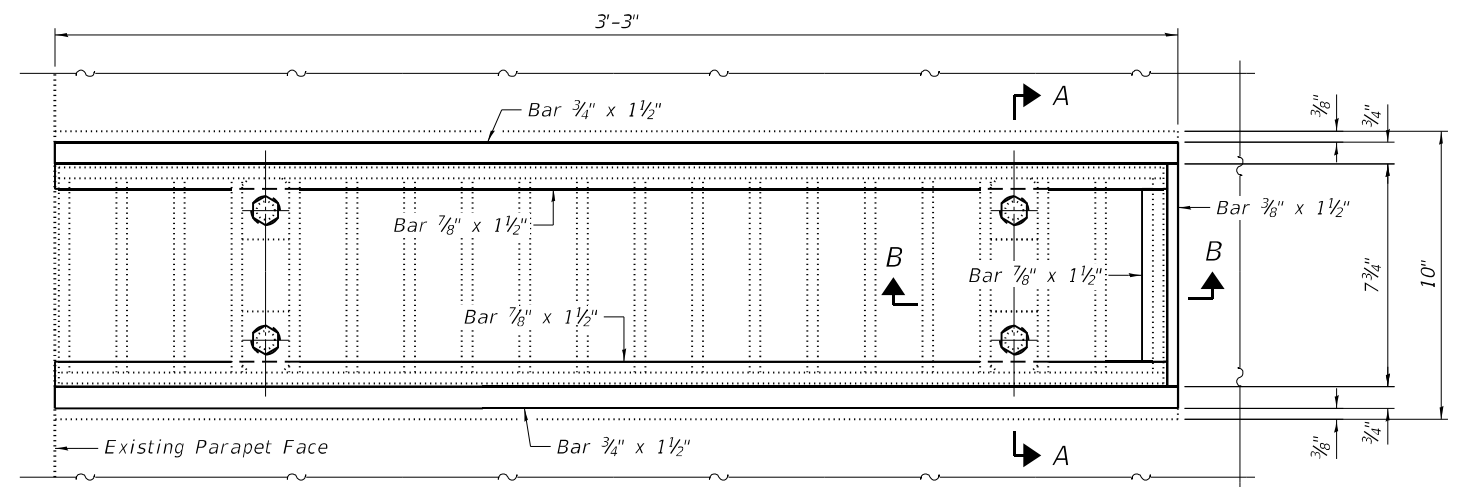

PLAN

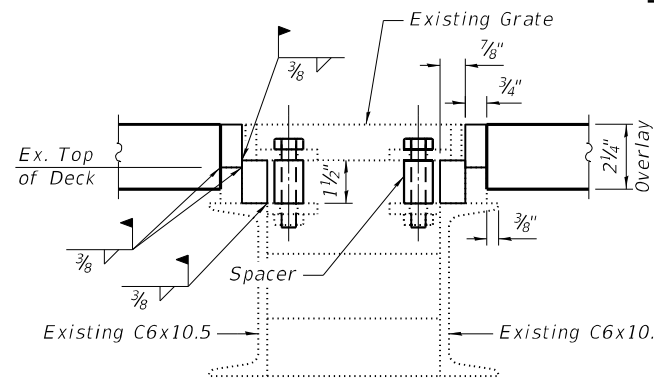

SECTION A-A

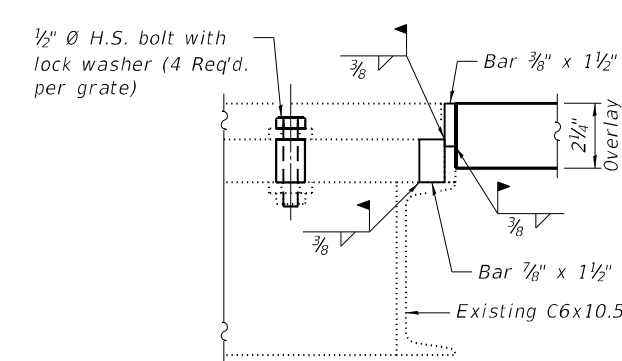

SECTION B-B

DRAINAGE SCUPPER ADJUSTING RING DETAILS

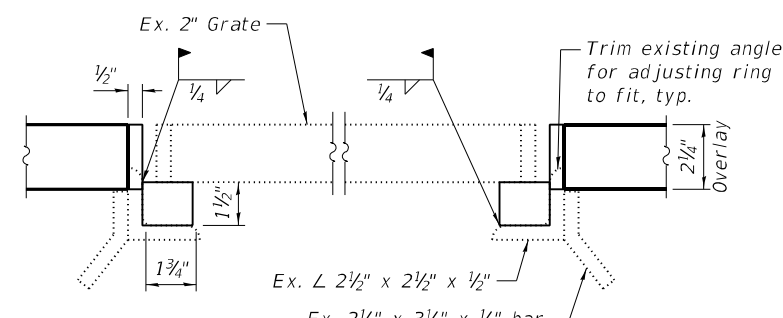

SECTION C-C

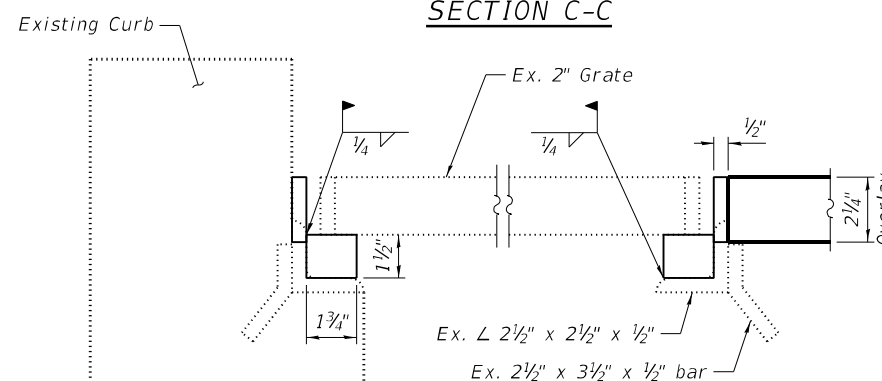

SECTION D-D

SHOULDER INLET ADJUSTING RING DETAILS

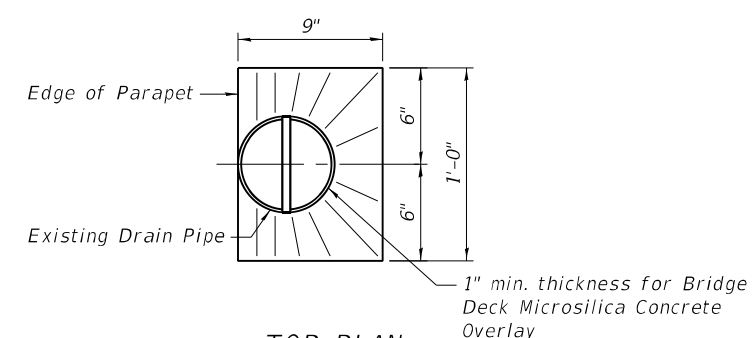

TOP PLAN

Overlay Transition at 6" Ø Drain Pipes

Notes:  
 All structural steel shall conform to AASHTO M270 Grade 36. The adjusting inlet ring and adjusting scupper ring shall be galvanized.  
 Bolts shall be 1/2" Ø, AASHTO M164 Type 1, mechanically galvanized.  
 The Contractor shall ensure that no damage is done to the existing grates that are to be reused.  
 Shop plans for the proposed adjusting scupper ring shall be submitted for approval prior to fabrication.  
 Cost of all labor and materials necessary to remove existing grates, clean existing scuppers, install adjusting scupper rings and reinstall grates is included in the cost per unit each for Drainage Scuppers to be Adjusted.  
 Shop plans for proposed adjusting inlet ring shall be submitted for approval prior to fabrication.  
 Cost of all labor and materials necessary to remove existing grates, clean existing inlets, install adjusting inlet rings and reinstall grates is included in the cost per unit each for Inlets to be Adjusted.

BILL OF MATERIAL

Item	Unit	Total
Inlets to be Adjusted	Each	4
Drainage Scuppers to be Adjusted	Each	4

MODEL: SMODELNAMES  
 FILE NAME: \$FILES



USER NAME = \$USERS\$	DESIGNED - ZLD	REVISED -
\$FILES\$	CHECKED - RPW	REVISED -
PLOT SCALE = \$SCALE\$	DRAWN - ZLD	REVISED -
PLOT DATE =	CHECKED - MDC	REVISED -

STATE OF ILLINOIS  
 DEPARTMENT OF TRANSPORTATION

DRAIN ADJUSTING DETAILS  
 STRUCTURE NO. 029-0055

SHEET 6 OF 15 SHEETS

F.A.P. RTE.	SECTION	COUNTY	TOTAL SHEETS	SHEET NO.
30	[139,138(BC;BC-1)BR,BR-1]BRR	FULTON	119	82
CONTRACT NO. 68H20				
ILLINOIS FED. AID PROJECT				

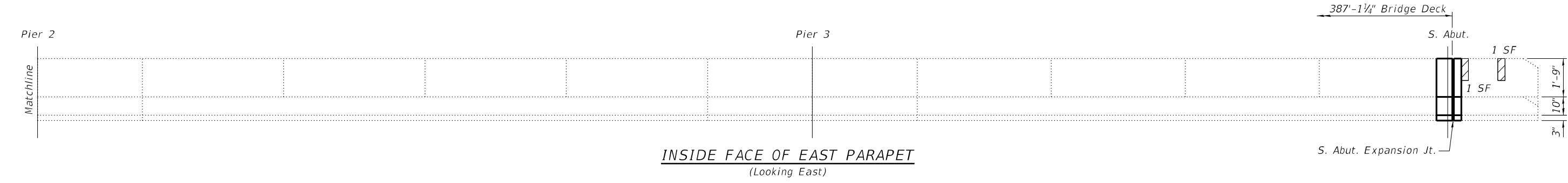
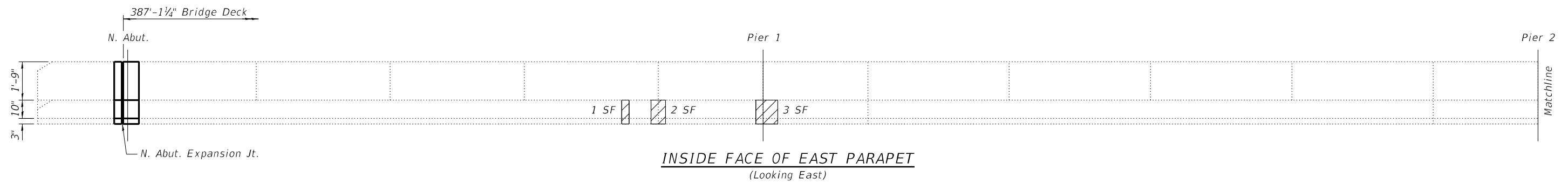
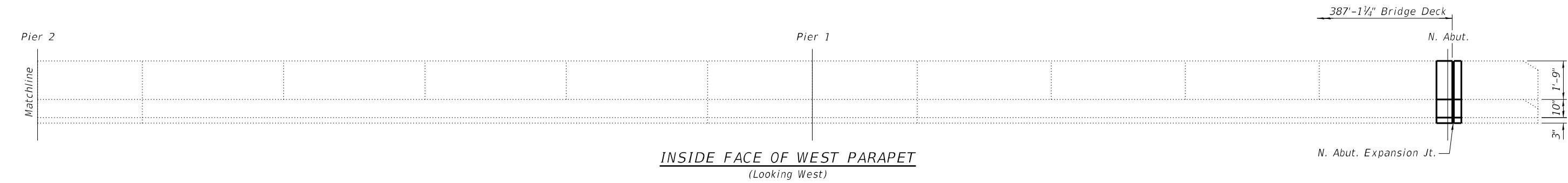
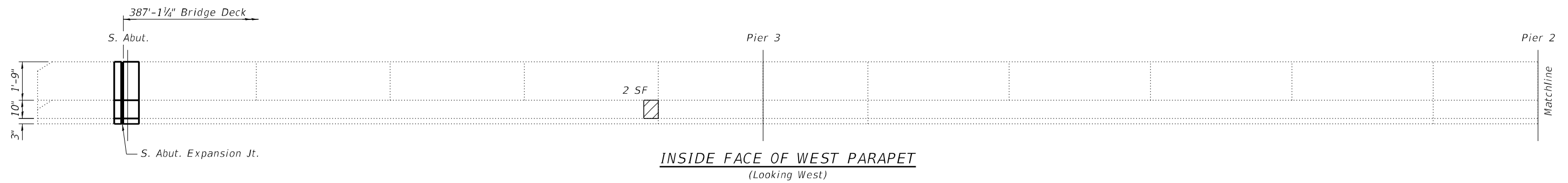

Note:  
For expansion joint details, see sheets  
8 thru 10 of 15.

**LEGEND**

Structural Repair of Concrete (Depth Equal to or less than 5")

**BILL OF MATERIAL**

Item	Unit	Total
Structural Repair of Concrete (Depth Equal to or less than 5")	Sq. Ft.	10

MODEL: \$MODELNAME\$  
FILE NAME: \$FILEL\$



USER NAME = \$USER\$	DESIGNED - ZLD	REVISED -
\$FILEL\$	CHECKED - RPW	REVISED -
PLOT SCALE = \$SCALE\$	DRAWN - ZLD	REVISED -
PLOT DATE =	CHECKED - MDC	REVISED -

**STATE OF ILLINOIS  
DEPARTMENT OF TRANSPORTATION**

**PARAPET REPAIRS  
STRUCTURE NO. 029-0055**

SHEET 7 OF 15 SHEETS

F.A.P. RTE.	SECTION	COUNTY	TOTAL SHEETS	SHEET NO.
30	[139,138(BC;BC-1)BR,BR-1]BRR	FULTON	119	83
			CONTRACT NO. 68H20	
		ILLINOIS	FED. AID PROJECT	

\* Cut to fit

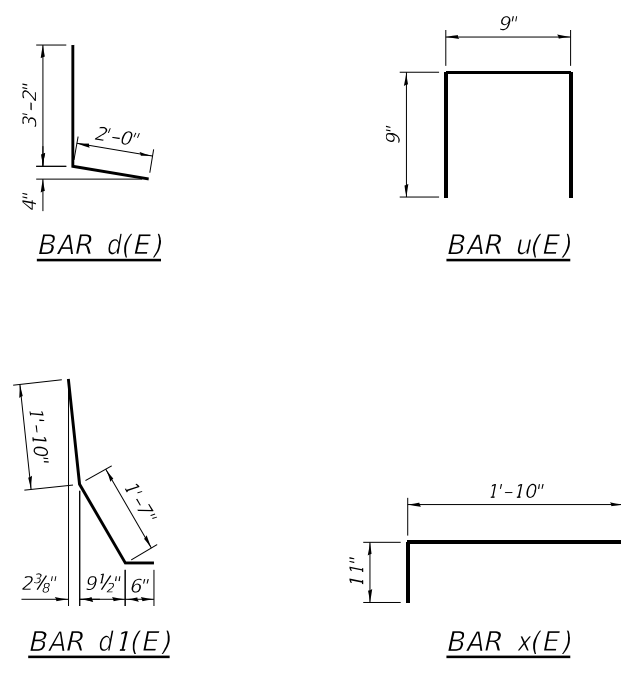
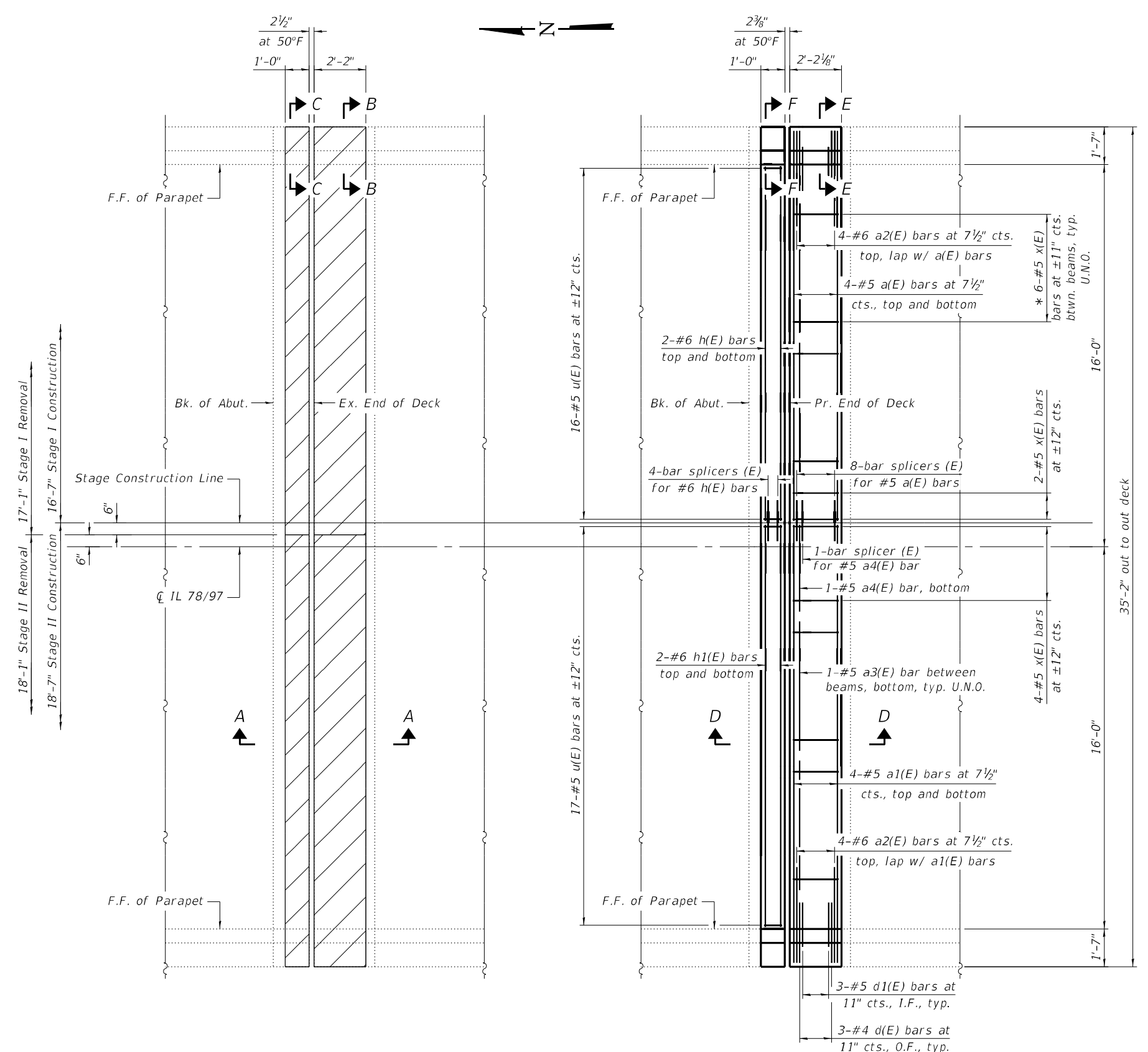

Notes:  
 Any reinforcement bars that are to remain that are damaged during concrete removal operations shall be repaired or replaced using an approved bar splicer or anchorage system. Cost included with Concrete Removal.  
 Existing longitudinal and vertical reinforcement bars remaining and extending into the removal areas shall be cleaned, straightened and incorporated into the new construction. Cost included with Concrete Removal.  
 See sheet 9 of 15 for sections.  
 See sheet 5 of 15 for overlay details.  
 See sheet 10 of 15 for joint seal details.

**BILL OF MATERIAL**

Bar	No.	Size	Length	Shape	
a(E)	16	#5	16'-0"	—	
a1(E)	16	#5	18'-0"	—	
a2(E)	16	#6	7'-4"	—	
a3(E)	8	#5	5'-5"	—	
a4(E)	2	#5	3'-7"	—	
d(E)	12	#4	5'-2"	L	
d1(E)	12	#5	3'-11"	\	
h(E)	8	#6	14'-8"	—	
h1(E)	8	#6	16'-8"	—	
u(E)	66	#5	2'-3"	U	
x(E)	60	#5	2'-9"	┌	
Item				Unit	Total
Concrete Removal				Cu. Yd.	10.4
Concrete Superstructure				Cu. Yd.	11.4
Reinforcement Bars, Epoxy Coated				Pound	1,600

**LEGEND**  
 Concrete Removal

**CONCRETE REMOVAL PLAN**  
 (N. Abut. Shown, S. Abut. Similar)

**CONCRETE REPLACEMENT PLAN**  
 (N. Abut. Shown, S. Abut. Similar)

MODEL: SMODELNAMES  
FILE NAME: \$FILES



USER NAME = \$USERS\$	DESIGNED - ZLD	REVISED -
\$FILESS\$	CHECKED - RPW	REVISED -
PLOT SCALE = \$SCALE\$	DRAWN - ZLD	REVISED -
PLOT DATE =	CHECKED - MDC	REVISED -

**STATE OF ILLINOIS  
 DEPARTMENT OF TRANSPORTATION**

**EXPANSION JOINT DETAILS  
 STRUCTURE NO. 029-0055**

SHEET 8 OF 15 SHEETS

F.A.P. RTE.	SECTION	COUNTY	TOTAL SHEETS	SHEET NO.
30	[139,138](BC,BC-1)BR,BR-1)BRR	FULTON	119	84
CONTRACT NO. 68H20				
ILLINOIS FED. AID PROJECT				

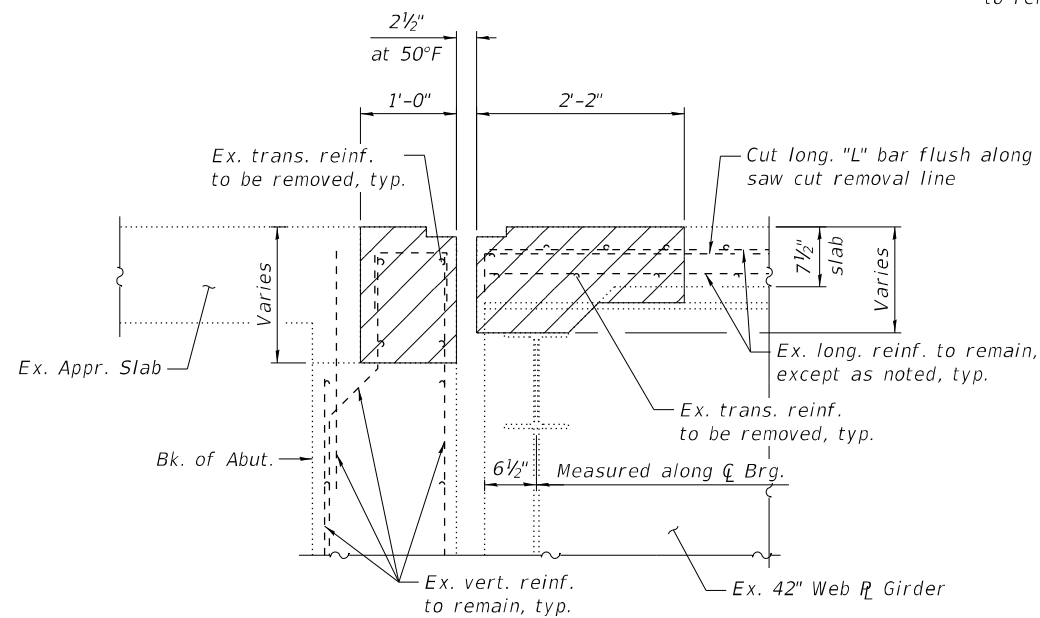

**SECTION A-A**

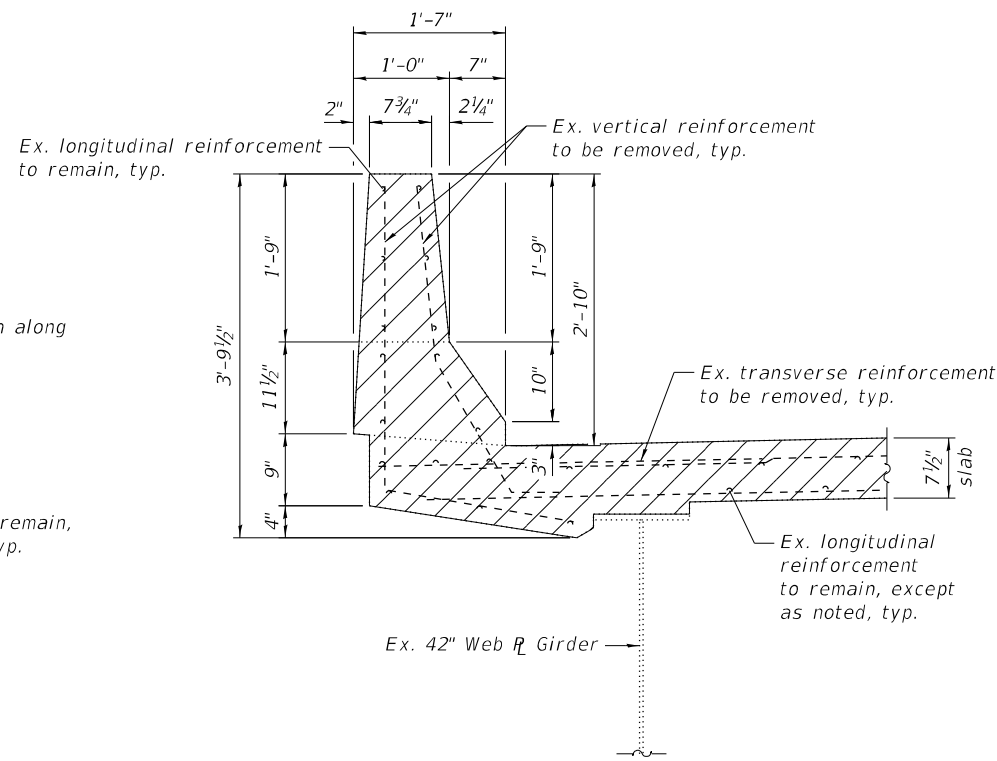

**SECTION B-B**

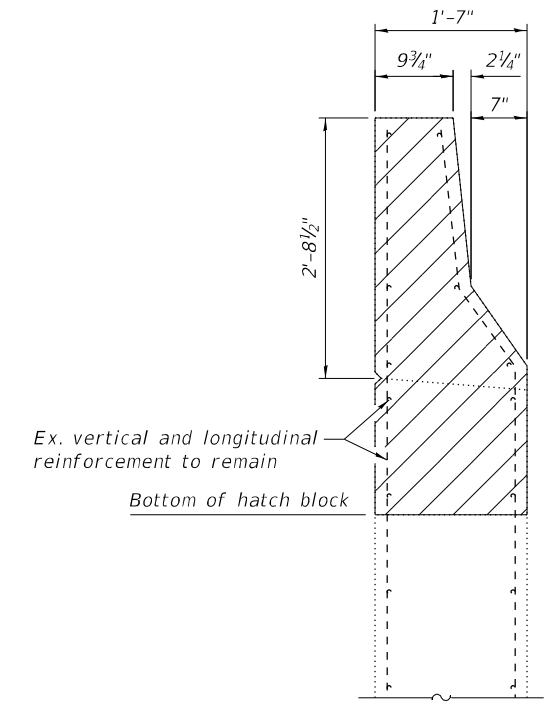

**SECTION C-C**

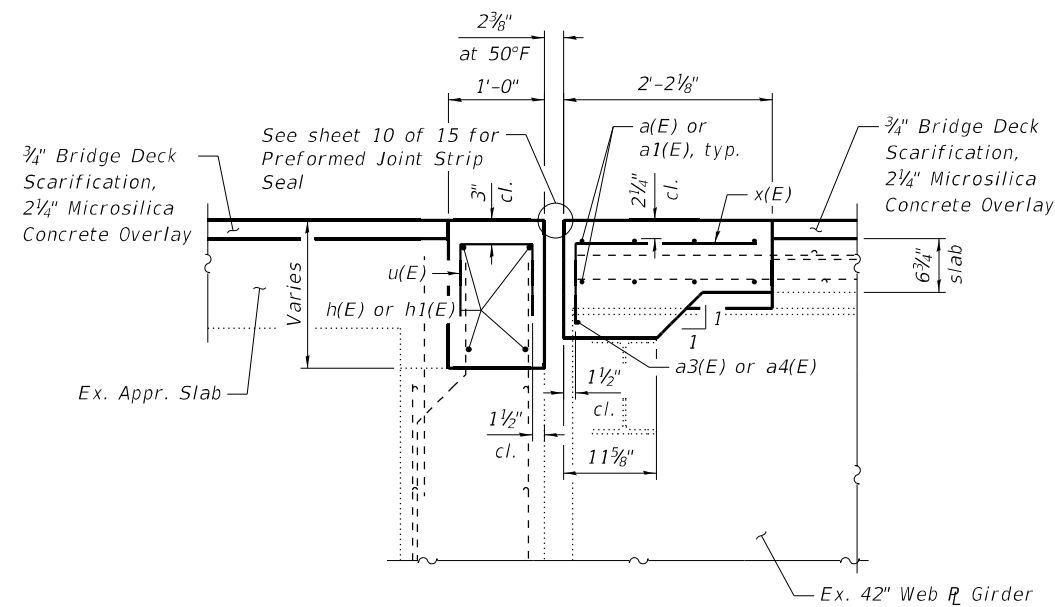

**SECTION D-D**

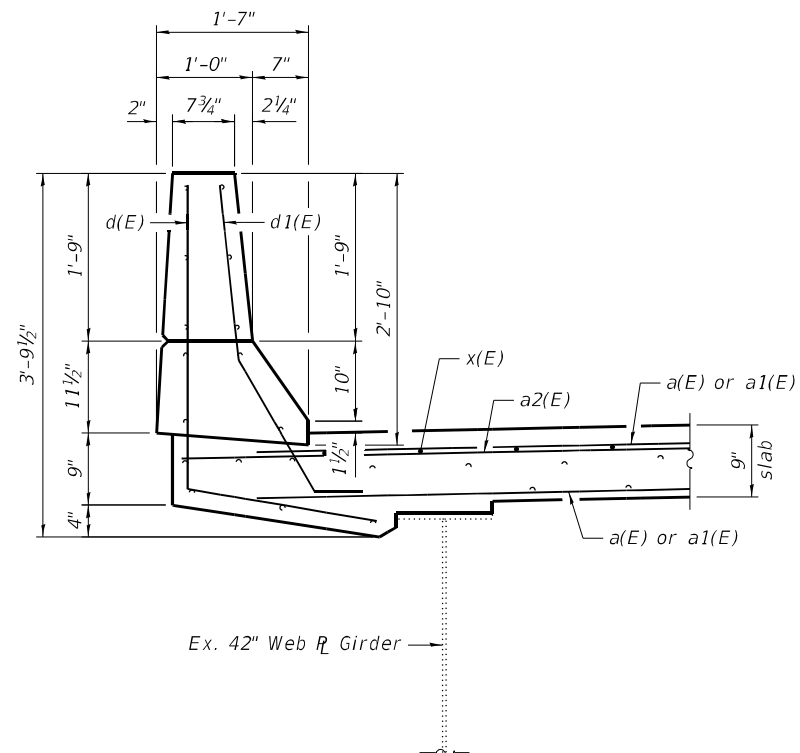

**SECTION E-E**

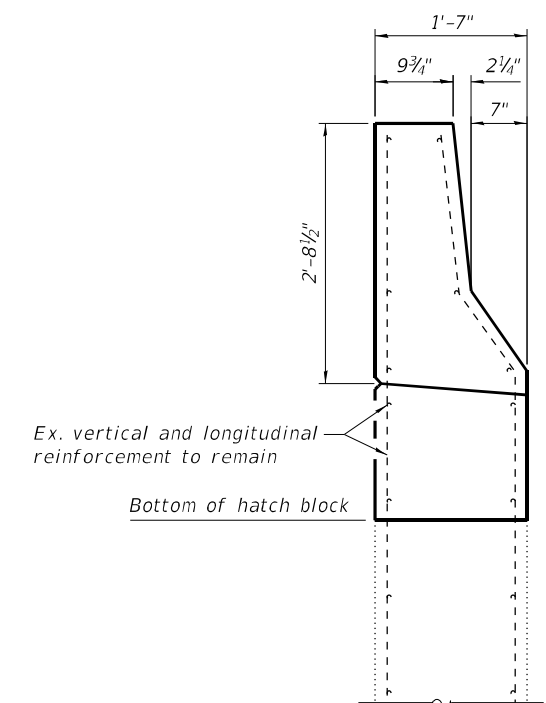

**SECTION F-F**

**LEGEND**

Concrete Removal

Notes:  
See sheet 8 of 15 for Bill of Material, section locations and additional details.  
See sheet 5 of 15 for overlay details.

MODEL: \$MODELNAME\$  
FILE NAME: \$FILES\$



USER NAME = \$USERS\$	DESIGNED - ZLD	REVISED -
\$FILES\$	CHECKED - RPW	REVISED -
PLOT SCALE = \$SCALE\$	DRAWN - ZLD	REVISED -
PLOT DATE =	CHECKED - MDC	REVISED -

**STATE OF ILLINOIS  
DEPARTMENT OF TRANSPORTATION**

**EXPANSION JOINT DETAILS  
STRUCTURE NO. 029-0055**

SHEET 9 OF 15 SHEETS

F.A.P. RTE.	SECTION	COUNTY	TOTAL SHEETS	SHEET NO.
30	[139,138(BC;BC-1)BR,BR-1]BRR	FULTON	119	85
CONTRACT NO. 68H20				
ILLINOIS FED. AID PROJECT				

SDATE\$ \$TIME\$

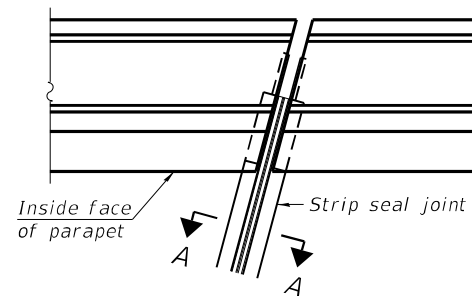

FOR SKEWS  $\leq 30^\circ$

PLAN AT PARAPET

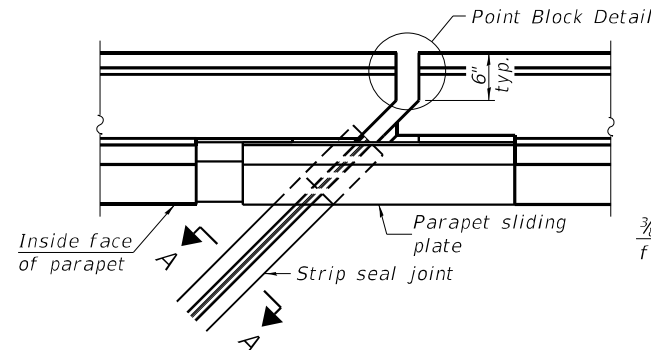

FOR SKEWS  $> 30^\circ$

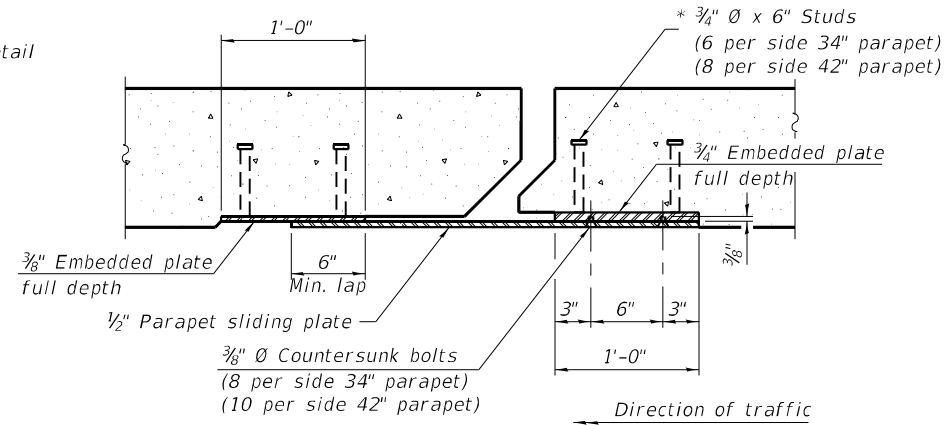

SECTION B-B

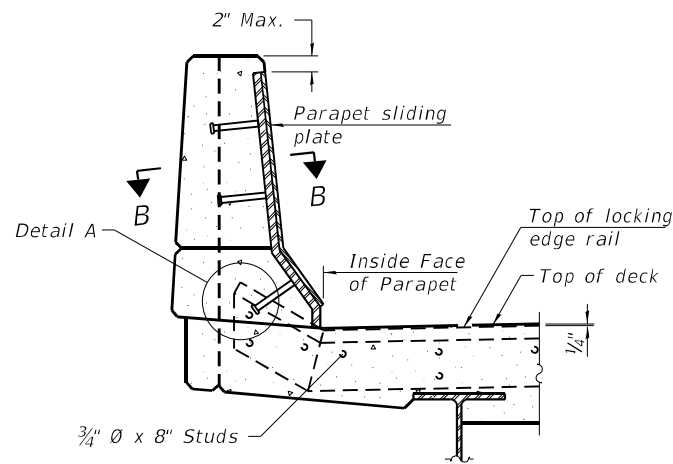

ELEVATION AT PARAPET

(Skews  $> 30^\circ$  shown. Skews  $\leq 30^\circ$  similar except as shown in plan view.)

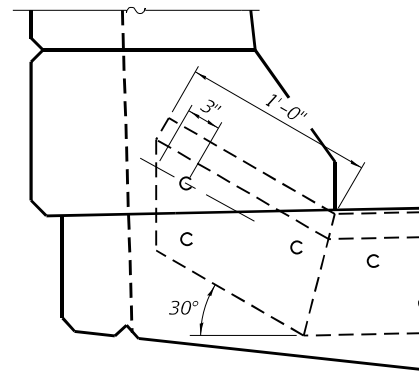

DETAIL A

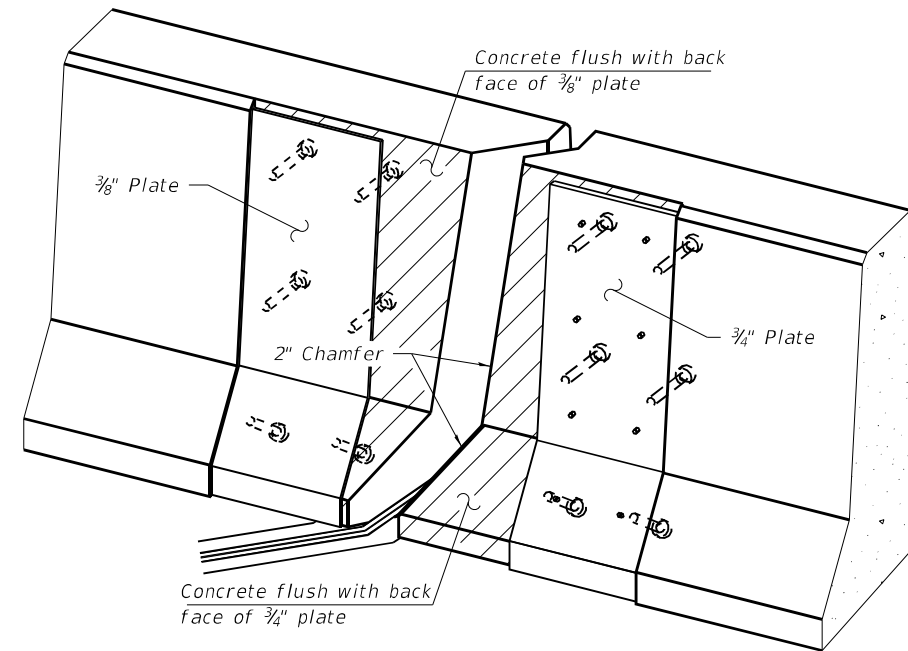

TRIMETRIC VIEW  
(Showing embedded plates only)

Notes:

The strip seal shall be made continuous and shall have a minimum thickness of  $1/4$ ". The configuration of the strip seal shall match the configuration of the locking edge rails. Open or "webbed" strip seal gland configurations are not permitted. The gland shall be sized for a maximum rated movement of 4 inches.

The locking edge rails depicted are configured for typical applications and are conceptual only. The actual configuration of the locking edge rails and matching strip seal may vary from manufacturer to manufacturer provided they fit the application and meet the minimum anchorage shown. Flanged edge rails, however, will not be allowed.

The manufacturer's recommended installation methods shall be followed.

All steel components shall be galvanized after fabrication according to Article 520.03 of the Standard Specifications.

The Maximum space between locking edge rail segments shall be  $3/16$ " and sealed with a suitable sealant; however, any rail joint within 10' measured perpendicular to the face of the curb or parapet shall be welded as shown in the locking edge rail splice detail.

Cost of parapet sliding plates, embedded plates, and anchorage studs included with Preformed Joint Strip Seal.

34" F-shape barrier shown, 42" F-shape similar as noted. The concrete opening below the strip seal will vary based on the locking edge rail chosen by the Contractor. Deck and parapet lengths shown elsewhere in the plans are dimensioned to the concrete opening, not the joint opening, and are based on the rolled locking edge rail. If the Contractor elects to use a different locking edge rail, dimensional adjustments may be required. One exception to this would be the strip seal joint at the end of the precast bridge approach slab. For these cases the pavement connector length shall be adjusted, not the length of the bridge approach slab.

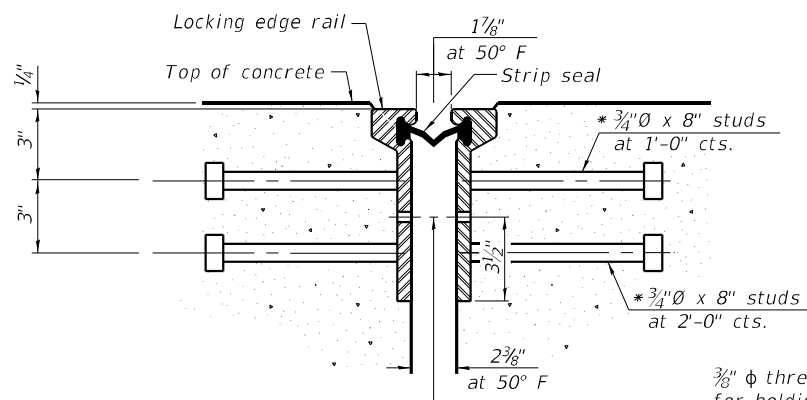

SHOWING ROLLED RAIL JOINT

$3/8$ "  $\phi$  threaded rods in  $7/16$ "  $\phi$  holes at  $\pm 4$ "-0" cts. for holding the proper joint opening based on the temperature during the deck pour. Place to miss studs. All rods shall be burned, or sawed off flush with the plates after concrete is set.

SECTION A-A

\* Granular or solid flux filled headed studs conforming to Article 1006.32 of the Std. Specs., automatically end welded.

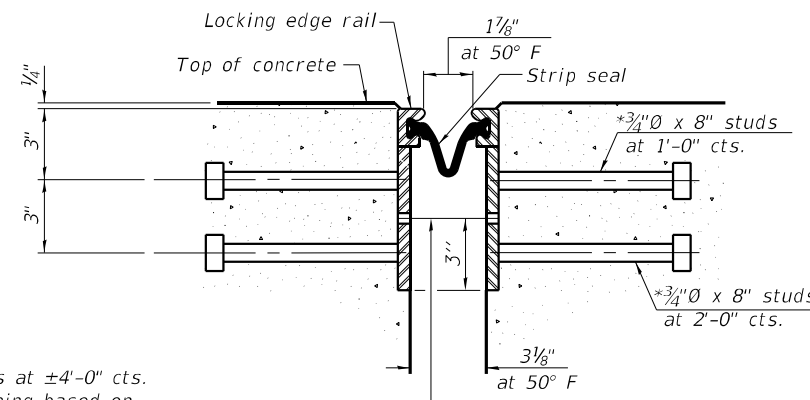

SHOWING WELDED RAIL JOINT

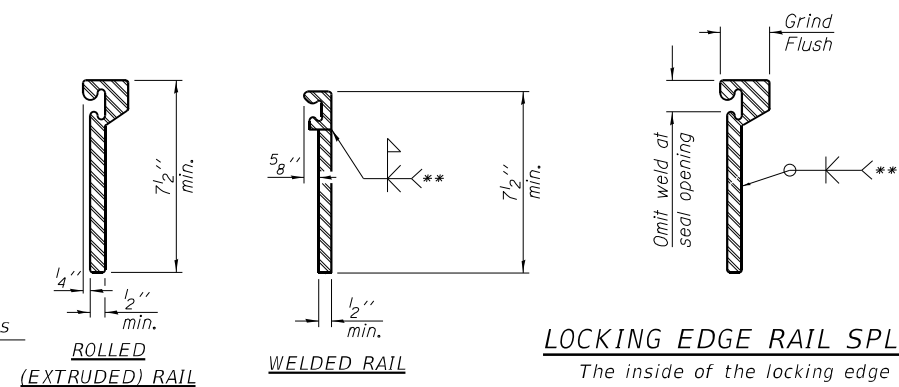

LOCKING EDGE RAILS

\*\* Back gouge not required if complete joint penetration is verified by mock-up.

LOCKING EDGE RAIL SPLICE

The inside of the locking edge rail groove shall be free of weld residue. Rolled rail shown, welded rail similar.

BILL OF MATERIAL

Item	Unit	Total
Preformed Joint Strip Seal	Foot	68

MODEL: SMODELNAMES  
FILE NAME: \$FILES

EJ-SS (TALL WITH GUTTER)

10-1-19



QUIGG ENGINEERING INC

USER NAME =	SUSERS	DESIGNED -	ZLD	REVISED -	
FILELESS		CHECKED -	RPW	REVISED -	
PLOT SCALE =	\$\$SCALE\$	DRAWN -	ZLD	REVISED -	
PLOT DATE =		CHECKED -	MDC	REVISED -	

STATE OF ILLINOIS  
DEPARTMENT OF TRANSPORTATION

PREFORMED JOINT STRIP SEAL  
STRUCTURE NO. 029-0055

SHEET 10 OF 15 SHEETS

F.A.P. RTE.	SECTION	COUNTY	TOTAL SHEETS	SHEET NO.
30	[139,138;BC;BC-1]BR, BR-1]BRR	FULTON	119	86
CONTRACT NO. 68H20				

ILLINOIS FED. AID PROJECT

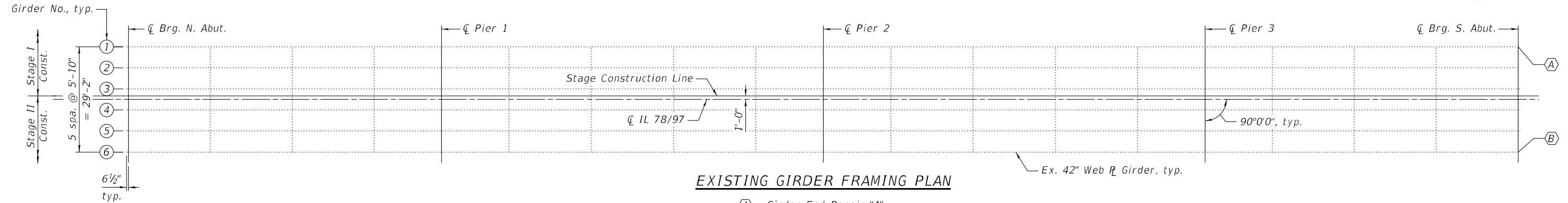

(A) - Girder End Repair "A"  
 (B) - Girder End Repair "B"

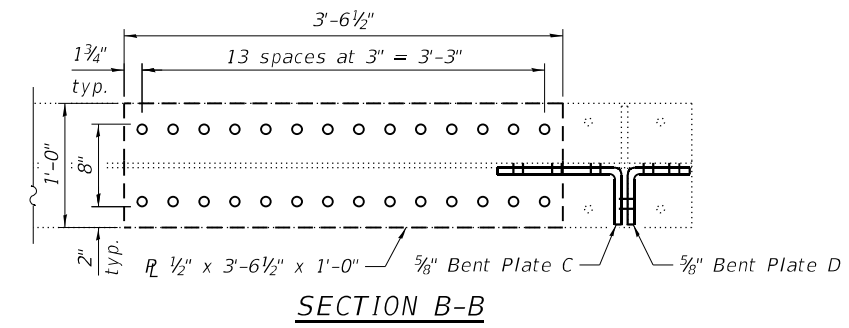
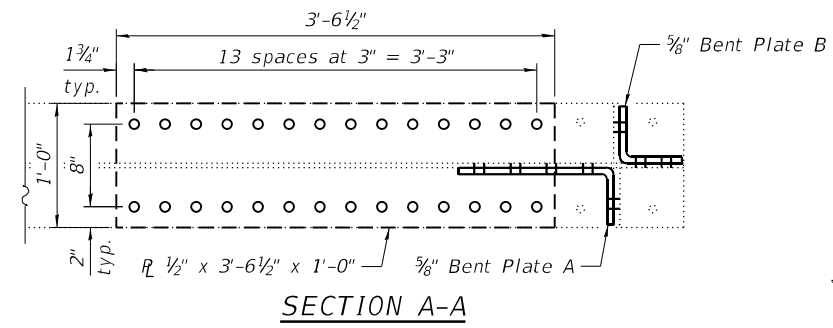
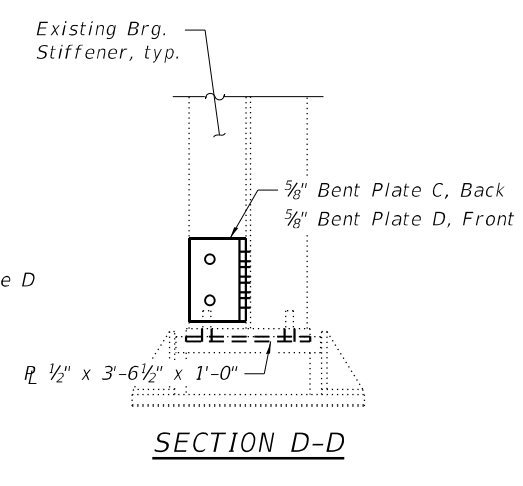
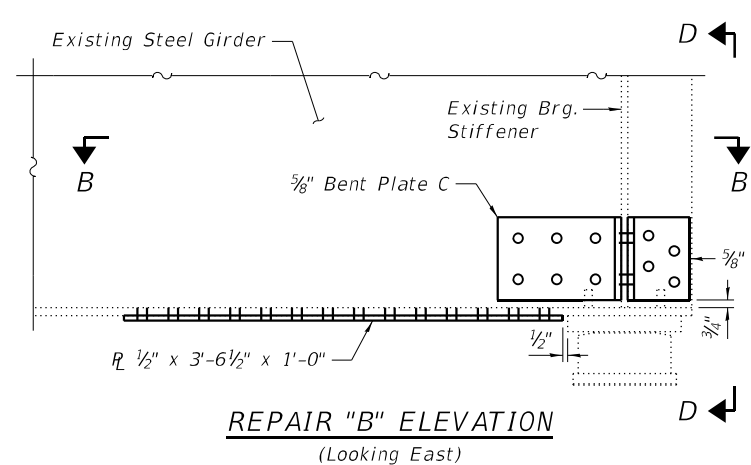
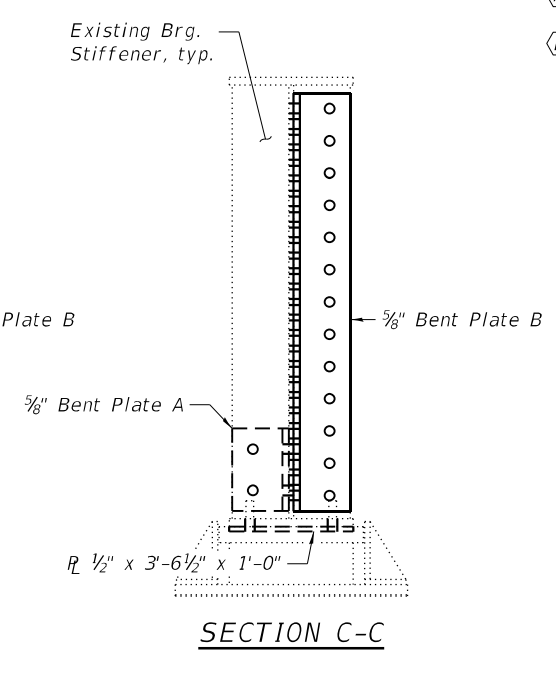
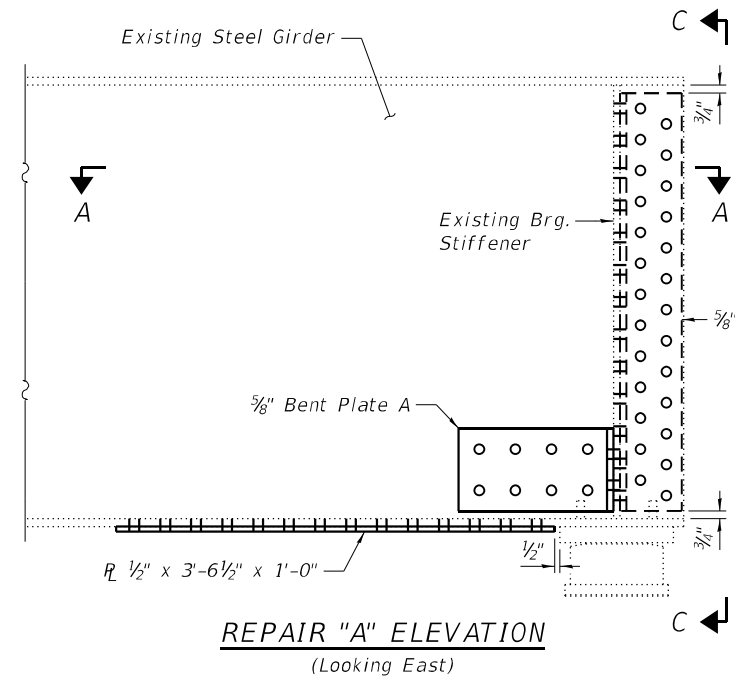

**Notes:**  
 Field drill 1 3/16" Ø holes for 3/4" Ø bolts into existing girder.  
 Use holes in new steel as template to field drill holes in existing steel.  
 All structural steel shall be AASHTO M270 Grade 50, unless otherwise noted.  
 Fasteners shall be ASTM A325 Type 1, mechanically galvanized bolts. Bolts 3/4" Ø, holes 1 3/16" Ø, unless otherwise noted.  
 All repair materials including structural steel plates, bolts, nuts and washers shall be galvanized per the special provision "Hot Dip Galvanizing for Structural Steel". Cost included in Structural Steel Repair.  
 Existing structural steel that will be in contact with new structural steel shall be cleaned and painted prior to erection as required by the special provision "Cleaning and Painting Contact Surface Areas of Existing Steel Structures". Cost included in Structural Steel Repair.

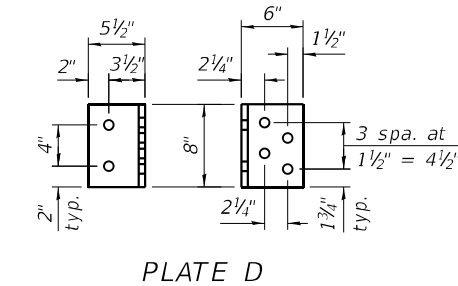
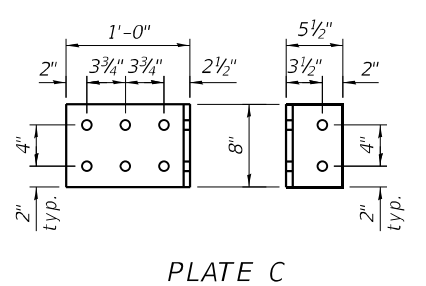
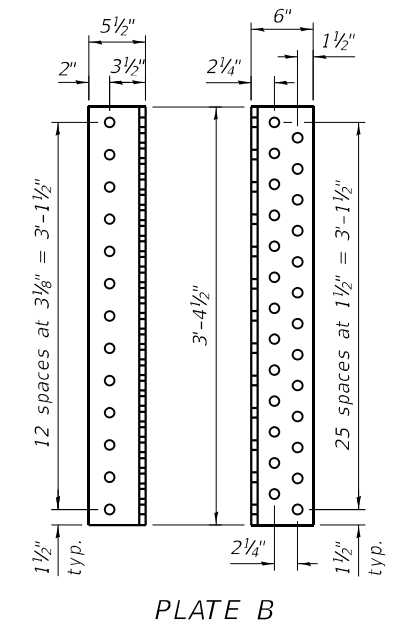
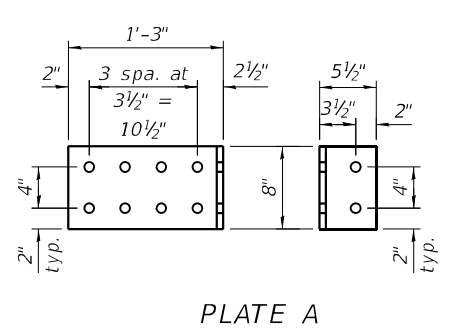

**BILL OF MATERIAL**

Item	Unit	Total
Structural Steel Repair	Pound	390

MODEL: Default; FILE NAME: S:\2023\231006 PTB 206-30 D4 - Hurst, Rosche - Various PH 1 & ILWO-2 Bridge Repair Plans 68H20\CAD\DD\CADD Sheets\0290055-68H20-011-Structural Steel Repairs.dgn

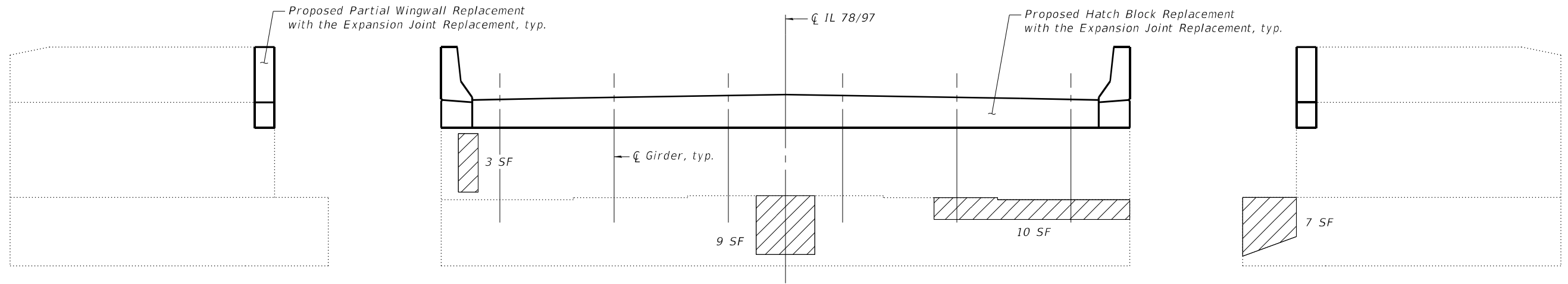

**NORTHWEST WINGWALL**  
(Looking East)

**NORTH ABUTMENT**  
(Looking North)

**NORTHEAST WINGWALL**  
(Looking West)

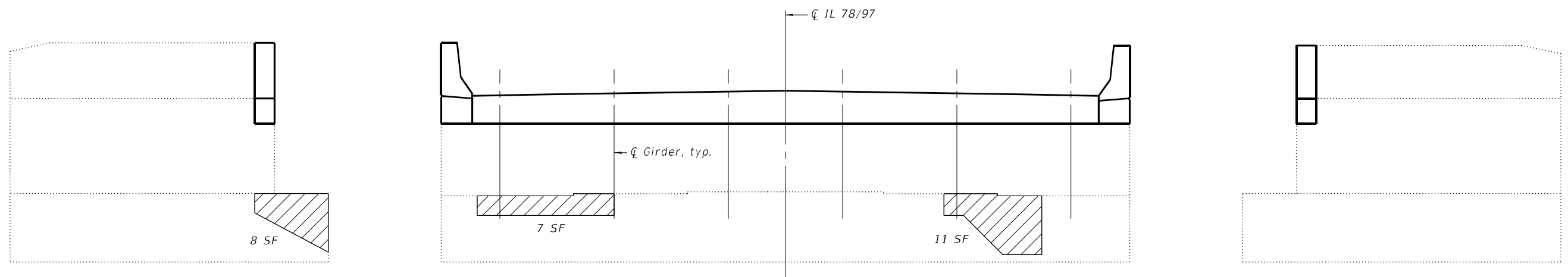

**SOUTHEAST WINGWALL**  
(Looking West)

**SOUTH ABUTMENT**  
(Looking South)

**SOUTHWEST WINGWALL**  
(Looking East)

Note:  
For wingwall and hatch block details with the expansion joint replacement, see sheets 8 and 9 of 15.

**LEGEND**

Structural Repair of Concrete (Depth Equal to or Less Than 5")

**BILL OF MATERIAL**

Item	Unit	Total
Structural Repair of Concrete (Depth Equal to or Less Than 5 Inches)	Sq. Ft.	55

MODEL: \$MODELNAME\$  
FILE NAME: \$FILES



USER NAME = \$USERS\$	DESIGNED - ZLD	REVISED -
\$FILESS\$	CHECKED - RPW	REVISED -
PLOT SCALE = \$SCALE\$	DRAWN - ZLD	REVISED -
PLOT DATE =	CHECKED - MDC	REVISED -

**STATE OF ILLINOIS  
DEPARTMENT OF TRANSPORTATION**

**ABUTMENT REPAIRS  
STRUCTURE NO. 029-0055**

SHEET 12 OF 15 SHEETS

F.A.P. RTE.	SECTION	COUNTY	TOTAL SHEETS	SHEET NO.
30	[139,138(BC;BC-1)BR,BR-1]BRR	FULTON	119	88
CONTRACT NO. 68H20				
ILLINOIS		FED. AID PROJECT		



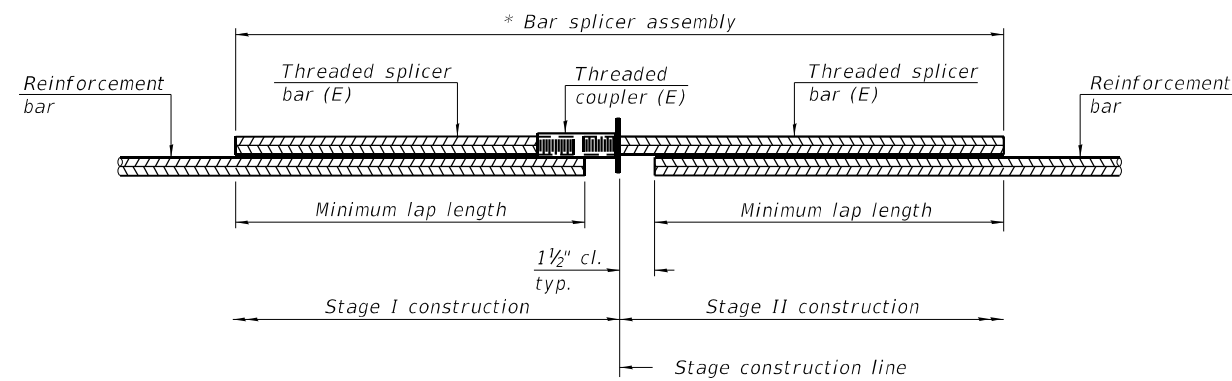

**STANDARD BAR SPLICER ASSEMBLY PLAN**

Only bar splicer assemblies as presented on the approved QPL list may be used.

Threaded splicer bar length = min. lap length + 1 1/2" + thread length

\* Epoxy not required on Bar Splicer Assembly components used in conjunction with black bars.

Location	Bar size	No. assemblies required	Minimum lap length
Bridge Deck Side of Exp. Jt.	#5	18	3'-4"
Appr. Side of Exp. Jt.	#6	8	4'-0"

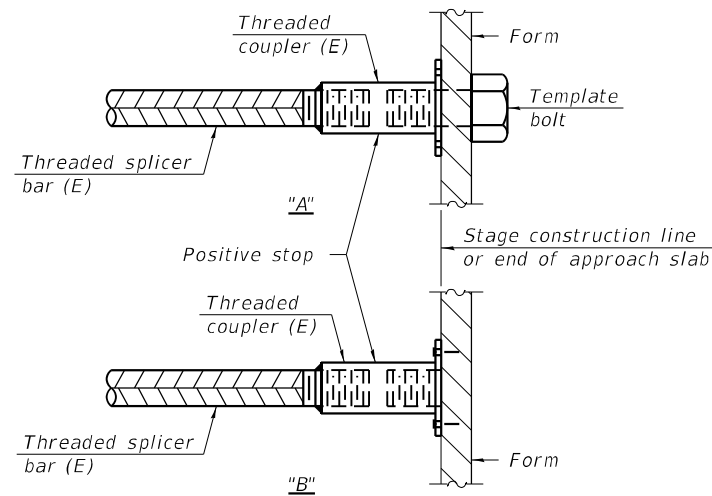

**INSTALLATION AND SETTING METHODS**

"A" : Set bar splicer assembly by means of a template bolt.

"B" : Set bar splicer assembly by nailing to wood forms or cementing to steel forms.

(E) : Indicates epoxy coating.

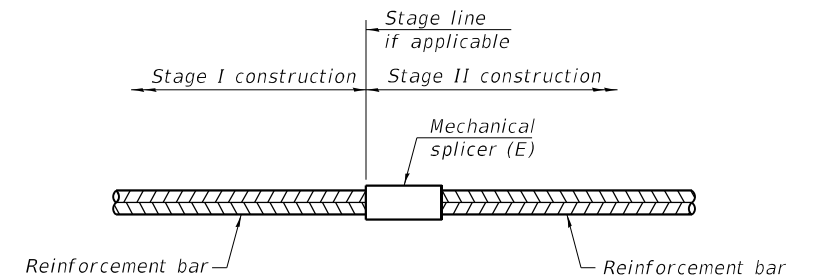

**STANDARD MECHANICAL SPLICER**

Location	Bar size	No. assemblies required

**Notes:**

Splicer bars shall be deformed with threaded ends and have a minimum 60 ksi yield strength.

All reinforcement shall be lapped and tied to the splicer bars.

Bar splicer assemblies shall be epoxy coated according to the requirements for reinforcement bars. See Section 508 of the Standard Specifications.

See approved list of bar splicer assemblies and mechanical splicers for alternatives.

MODEL: \$MODELNAME\$  
FILE NAME: \$FILES\$

BSD-1

2-1-2023



USER NAME = \$USERS\$	DESIGNED - ZLD	REVISED -
\$FILES\$	CHECKED - RPW	REVISED -
PLOT SCALE = \$SCALE\$	DRAWN - ZLD	REVISED -
PLOT DATE =	CHECKED - MDC	REVISED -

STATE OF ILLINOIS  
DEPARTMENT OF TRANSPORTATION

BAR SPLICER ASSEMBLY AND MECHANICAL SPLICER DETAILS  
STRUCTURE NO. 029-0055

SHEET 13 OF 15 SHEETS

F.A.P. RTE.	SECTION	COUNTY	TOTAL SHEETS	SHEET NO.
30	[139,138(BC;BC-1)BR,BR-1]BRR	FULTON	119	89
CONTRACT NO. 68H20				
ILLINOIS FED. AID PROJECT				

\$DATE\$ \$TIME\$

ROUTE NO.	SECTION	COUNTY	TOTAL SHEETS	SHEET NO.
F.A.P. 30	(138BC-1)BR	FULTON	86	24
FED. ROAD DIST. NO. 7 ILLINOIS FED. AID PROJECT				

SHEET NO. 8  
21 SHEETS

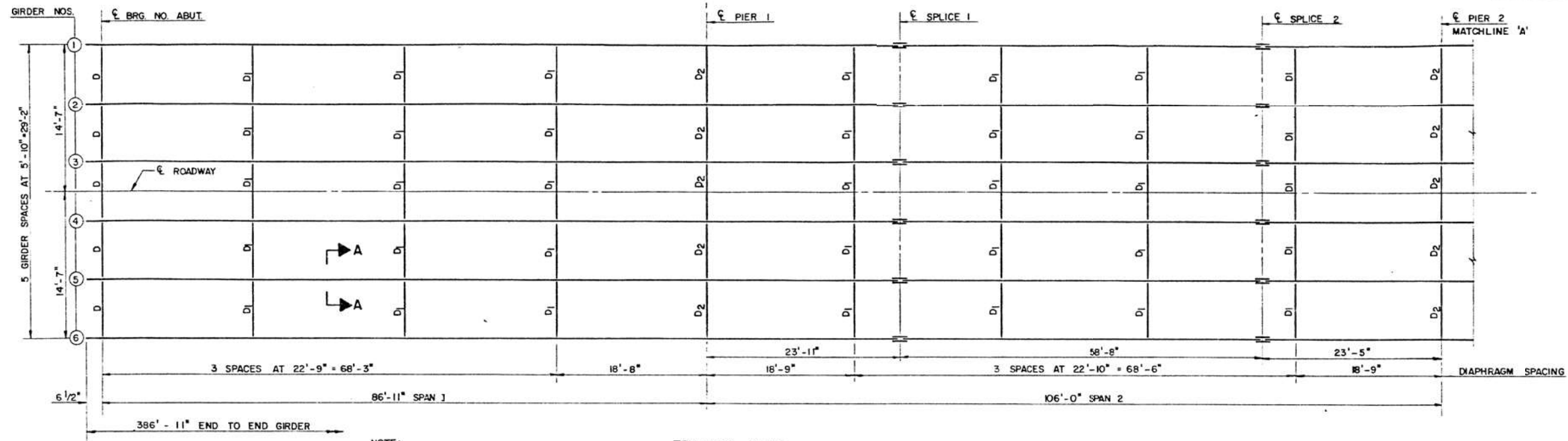

NOTE:  
DIAPHRAGMS BETWEEN GIRDER ③ & ④  
TO BE PLACED DURING STAGE II  
CONSTRUCTION.

FRAMING PLAN



D - END DIAPHRAGM (W12 x 40)  
D<sub>1</sub> - INTERIOR DIAPHRAGM (W16 x 36)  
D<sub>2</sub> - INTERIOR DIAPHRAGM AT PIERS (W16 x 36)

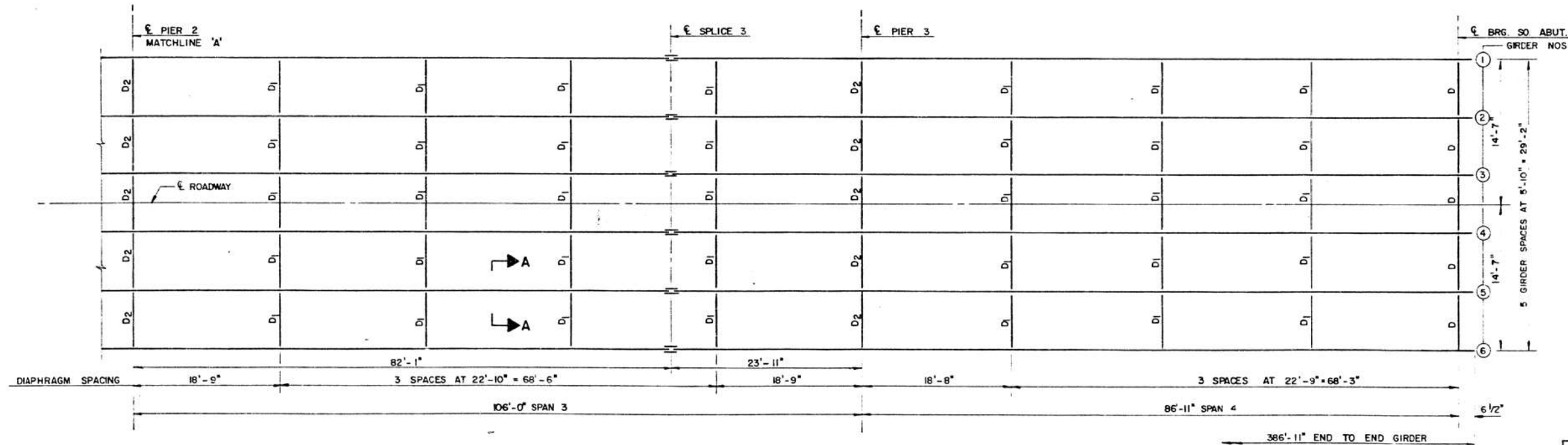

FRAMING PLAN



WELLS ENGINEERS, INC.

FRAMING PLAN  
IL. ROUTES 78 & 97  
OVER SPOON RIVER OVERFLOW  
F.A.P. RTE. 30 SEC. (138BC-1)BR  
STA. 493 + 00.00  
FULTON COUNTY

STRUCTURE NO. 029 - 0055		
DATE: 6-29-87	DRAWN BY: GLH	JOB NO. 860672
DESIGNED BY: KRP	CHECKED BY: SDK	SHEET NO. 8 OF 21

FOR INFORMATION ONLY

MODEL: SMODELNAMES  
FILE NAME: \$FILES



QUIGG ENGINEERING INC

USER NAME = \$USERS	DESIGNED - ZLD	REVISED -
\$FILES	CHECKED - RPW	REVISED -
PLOT SCALE = \$SCALE	DRAWN - ZLD	REVISED -
PLOT DATE =	CHECKED - MDC	REVISED -

STATE OF ILLINOIS  
DEPARTMENT OF TRANSPORTATION

EXISTING PLANS REFERENCE SHEET  
STRUCTURE NO. 029-0055

SHEET 14 OF 15 SHEETS

F.A.P. RTE.	SECTION	COUNTY	TOTAL SHEETS	SHEET NO.
30	(139,138/BC/BC-1)BR, BR-1)BR	FULTON	119	90
CONTRACT NO. 68H20				
ILLINOIS FED. AID PROJECT				

SDATE\$ STIME\$

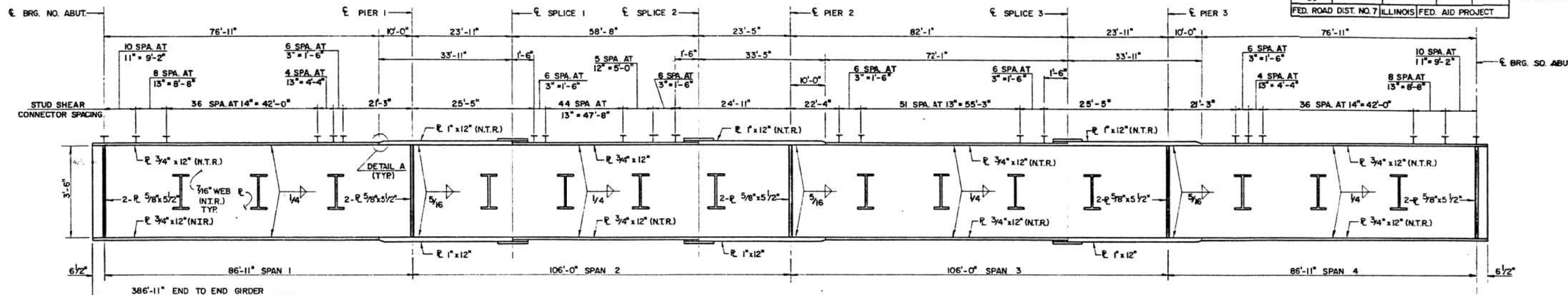

**GIRDER ELEVATION**  
(ALL GIRDER STEEL IS AASHTO M223, GR. 50)

N.T.R. = NOTCH TOUGHNESS REQUIREMENTS

ITEM		0.4 SPAN 1 OR 4	PIERS 1 OR 3	0.5 SPAN 2 OR 3	PIER 2
I <sub>s</sub>	(in <sup>4</sup> )	10926	13797	10926	13797
I <sub>c</sub>	(in <sup>4</sup> )	26637	—	26637	—
S <sub>s</sub>	(in <sup>3</sup> )	502	627	502	627
S <sub>c</sub>	(in <sup>3</sup> )	702	—	702	—
ϕ	(k/ft)	0.72	1.02	0.72	1.02
M <sub>ϕ</sub>	(k)	368	937	311	929
S <sub>ϕ</sub>	(k/ft)	0.28	—	0.28	—
M <sub>S</sub> ϕ	(k)	166	—	168	—
M <sub>L</sub>	(k)	579	439	620	474
M <sub>imp</sub>	(k)	137	100	135	103
5/3 (M <sub>L</sub> + I)	(k)	1194	899	1259	962
M <sub>a</sub>	(k)	2247	2387	2260	2459
M <sub>u</sub>	(k)	—	—	—	—
f <sub>s</sub> ϕ non-comp	(k.s.i)	8.8	19.0	7.5	17.8
f <sub>s</sub> ϕ (comp) n=9	(k.s.i)	2.9	—	2.9	—
f <sub>s</sub> 5/3 (L + I) n=9	(k.s.i)	20.5	17.2	21.6	18.5
f <sub>s</sub> (Overload)	(k.s.i)	32.2	35.2	32.0	36.3
f <sub>s</sub> (Total)	(k.s.i)	41.9	45.8	41.6	47.2
VR	(K)	45.5	—	39.0	—

ITEM	ABUTMENT	PIER 1 OR 3	PIER 2	
* R <sub>ϕ</sub>	(k)	33.0	108.0	107.0
* R <sub>L</sub>	(k)	33.5	52.0	54.0
* Imp.	(k)	8.0	8.5	8.0
* R TOTAL	(k)	74.5	168.5	169.0

M<sub>ϕ</sub> (APPLIED MOMENT) = 1.3 [M<sub>ϕ</sub> + M<sub>S</sub> ϕ + 5/3 (M<sub>L</sub> + I)]  
 I<sub>s</sub> AND S<sub>s</sub> ARE THE MOMENT OF INERTIA AND SECTION MODULUS OF THE STEEL SECTION USED IN COMPUTING f<sub>s</sub> (OVERLOAD).  
 I<sub>c</sub> AND S<sub>c</sub> ARE THE MOMENT OF INERTIA AND SECTION MODULUS OF THE COMPOSITE SECTION USED IN COMPUTING f<sub>s</sub> (OVERLOAD).  
 V<sub>R</sub> IS THE MAXIMUM L + IMPACT SHEAR RANGE IN SPAN.  
 THE FULLY PLASTIC MOMENT CAPACITY (M<sub>u</sub>) IS COMPUTED ACCORDING TO AASHTO 10.48.1 AND 10.50.1  
 f<sub>s</sub> (TOTAL) IS THE SUM OF THE STRESSES DUE TO 1.3 [M<sub>ϕ</sub> + M<sub>S</sub> ϕ + 5/3 (M<sub>L</sub> + I)] COMPUTED ACCORDING TO AASHTO 10.48.1 AND 10.50.1  
 f<sub>s</sub> (OVERLOAD) IS THE SUM OF THE STRESSES DUE TO M<sub>ϕ</sub> + M<sub>S</sub> ϕ + 5/3 (M<sub>L</sub> + I).  
 \* THESE VALUES ARE SERVICE LOAD.

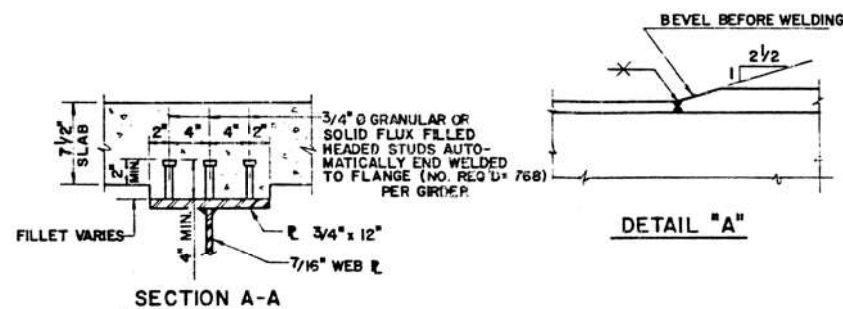
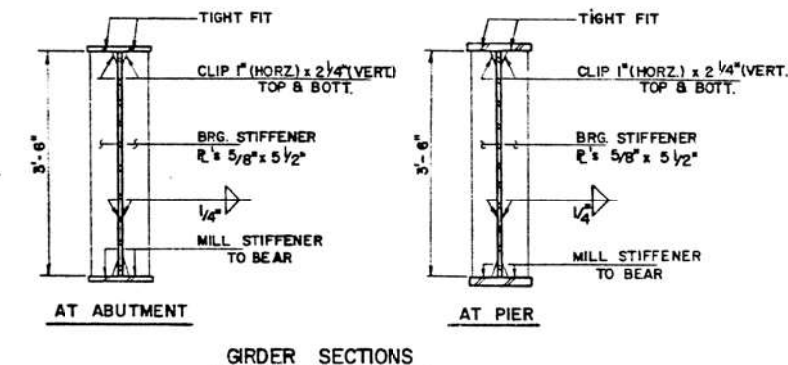

\*\* FOR FABRICATION ONLY

GIRDER NOS.	℄ BRG. NO. ABUT.	℄ PIER 1	℄ SPLICE 1	℄ SPLICE 2	℄ PIER 2	℄ SPLICE 3	℄ PIER 3	℄ BRG. SQ. ABUT.
1	453.02	453.58	453.78	453.94	453.86	453.78	453.59	453.04
2	453.13	453.69	453.89	454.05	453.97	453.89	453.70	453.15
3	453.27	453.78	453.98	454.14	454.06	453.98	453.79	453.24
4	453.22	453.78	453.98	454.14	454.06	453.98	453.79	453.24
5	453.13	453.69	453.89	454.05	453.97	453.98	453.70	453.15
6	453.02	453.58	453.78	453.94	453.86	453.78	453.59	453.04

**FOR INFORMATION ONLY**

**WELLS ENGINEERS, INC.**  
 FRAMING DETAILS  
 IL ROUTES 78 & 97  
 OVER SPOON RIVER OVERFLOW  
 F.A.P. RTE. 30 SEC. (138BC-1)BR  
 STA. 493 + 00.00  
 FULTON COUNTY  
 STRUCTURE NO. 029 - 0055  
 DATE: 6-29-87 DRAWN BY: GLH JOB NO. 860672  
 DESIGNED BY: KRP CHECKED BY: SDK SHEET NO. 9 OF 21

Existing Structure: SN 029-0056, originally built in 1989 as a four-span plate girder superstructure with stub abutments and solid wall piers. The back to back length = 591'-9" and the out to out width = 35'-2". Structure is to be repaired as detailed in these plans. Traffic is to be maintained using stage construction.

No salvage.

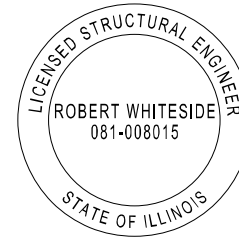

*Robert Whiteside*

Robert Whiteside, Illinois S.E. 081-008015  
Expires 11/30/2024

12/14/2023  
Date

**INDEX OF SHEETS**

1. General Plan and Elevation
2. General Data
3. Stage Construction Details
4. Temporary Concrete Barrier
5. Deck Overlay Plan
6. Drain Adjusting Details
7. Parapet Repairs
- 8-9. Expansion Joint Details
10. Preformed Joint Strip Seal
11. Structural Steel Repairs
12. Abutment Repairs
13. Bar Splicer Assembly and Mechanical Splicer Details
- 14-15. Existing Plans Reference Sheets

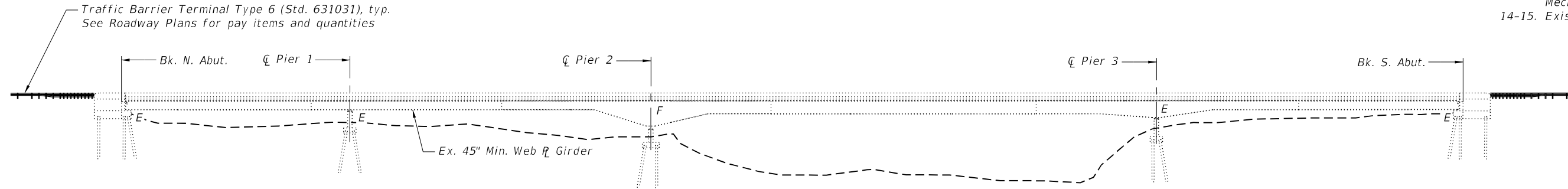

**ELEVATION**

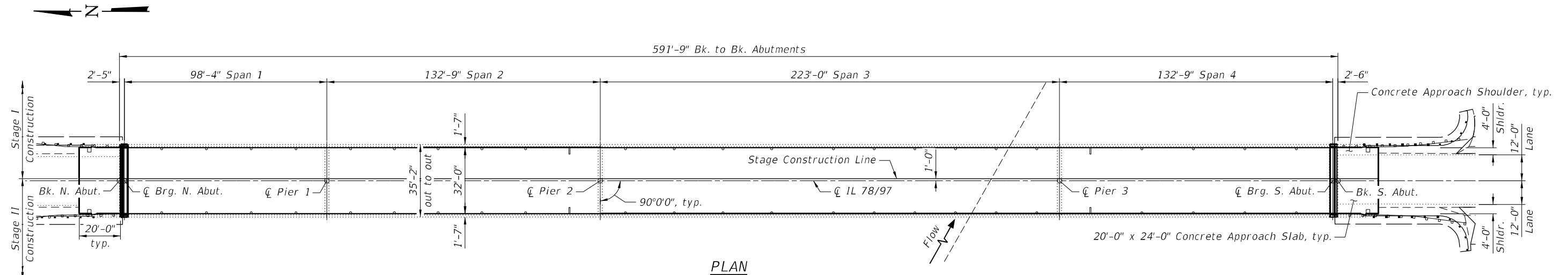

**PLAN**

**DESIGN STRESSES**

FIELD UNITS (EXIST. CONST.)

$f'_c = 3,500$  psi  
 $f_y = 60,000$  psi (Reinforcement)  
 $f_y = 50,000$  psi (M-223 Grade 50, Structural Steel)  
 $f_y = 36,000$  psi (M-183, Structural Steel)

FIELD UNITS (NEW CONST.)

$f'_c = 4,000$  psi  
 $f_y = 60,000$  psi (Reinforcement)  
 $f_y = 36,000$  psi (M270 Grade 36)  
 $f_y = 50,000$  psi (M270 Grade 50)

**LOADING HS20-44**

Existing and Proposed

**DESIGN SPECIFICATIONS**

2002 AASHTO Standard Specifications  
for Highway Bridges - LFD

**SCOPE OF WORK**

1. Replace the transverse expansion joints.
2. Scarify the bridge deck and approach pavements.
3. Complete full depth deck repairs.
4. Place a microsilica concrete overlay.
5. Concrete repair of parapets.
6. Structural steel repairs.
7. Concrete repair of abutments.

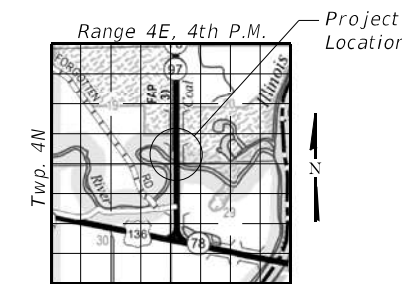

**LOCATION SKETCH**

**GENERAL PLAN AND ELEVATION**  
**IL 78/97 OVER SPOON RIVER**  
**FAP ROUTE 30**  
**SECTION [139,138(BC;BC-1)BR,BR-1]BRR**  
**FULTON COUNTY**  
**STRUCTURE NO. 029-0056**

MODEL: SMODELNAMES  
FILE NAME: \$FILES



QUIGG ENGINEERING INC

USER NAME = \$USERS\$	DESIGNED - ZLD	REVISED -
\$FILES\$	CHECKED - RPW	REVISED -
PLOT SCALE = \$SCALE\$	DRAWN - JDC	REVISED -
PLOT DATE =	CHECKED - MDC	REVISED -

**STATE OF ILLINOIS**  
**DEPARTMENT OF TRANSPORTATION**

**GENERAL PLAN AND ELEVATION**  
**STRUCTURE NO. 029-0056**

SHEET 1 OF 15 SHEETS

F.A.P. RTE.	SECTION	COUNTY	TOTAL SHEETS	SHEET NO.
30	[139,138(BC;BC-1)BR,BR-1]BRR	FULTON	119	92
CONTRACT NO. 68H20				
ILLINOIS FED. AID PROJECT				

SDATE\$ \$TIME\$

GENERAL NOTES

Fasteners shall be ASTM A325 Type 1, mechanically galvanized bolts. Bolts 3/4" Ø, holes 13/16" Ø, unless otherwise noted.

Calculated weight of Structural Steel = 960 lbs (M270 Grade 50)

All structural steel shall be AASHTO M270 Grade 50, unless otherwise noted.

No field welding is permitted except as specified in the contract documents.

Reinforcement bars designated (E) shall be epoxy coated.

Plan dimensions and details relative to existing plans are subject to nominal construction variations. The Contractor shall field verify existing dimensions and details affecting new construction and make necessary approved adjustments prior to construction or ordering of materials. Such variations shall not be cause for additional compensation for a change in scope of the work, however, the Contractor will be paid for the quantity actually furnished at the unit price bid for the work.

Any reinforcement bars that are to remain that are damaged during concrete removal operations shall be repaired or replaced using an approved bar splicer or anchorage system. Cost included with Concrete Removal.

Existing longitudinal and vertical reinforcement bars remaining and extending into the removal areas shall be cleaned, straightened and incorporated into the new construction. Cost included with Concrete Removal.

Prior to pouring the new concrete deck, all heavy or loose rust, loose mill scale, and other loose or potentially detrimental foreign material shall be removed from the surfaces in contact with concrete. Tightly adhered paint may remain unless otherwise noted. Removal shall be accomplished by methods that will not damage the steel and the cost will be included in the pay item covering removal of the existing concrete.

The protective coat shall be applied to the new microsilica concrete overlay, new bridge deck concrete, and top and inside faces of the new portions of the parapets and wingwalls.

Joint openings shall be adjusted according to Article 520.04 of the Standard Specifications when the deck is poured at an ambient temperature other than 50°F.

All repair materials including structural steel angles, bolts, nuts and washers shall be galvanized per the special provision "Hot Dip Galvanizing for Structural Steel". Cost included in Structural Steel Repair.

TOTAL BILL OF MATERIAL

Item	Unit	Super	Sub	Total
Concrete Removal	Cu. Yd.	10.5	-	10.5
Concrete Superstructure	Cu. Yd.	11.4	-	11.4
Bridge Deck Grooving	Sq. Yd.	2,101	-	2,101
Protective Coat	Sq. Yd.	2,246	-	2,246
Reinforcement Bars, Epoxy Coated	Pound	1,600	-	1,600
Bar Splicers	Each	26	-	26
Preformed Joint Strip Seal	Foot	68	-	68
Inlets to be Adjusted	Each	4	-	4
Structural Steel Repair	Pound	960	-	960
Bridge Deck Scarification 3/4"	Sq. Yd.	2,219	-	2,219
Bridge Deck Microsilica Concrete Overlay 2 1/4"	Sq. Yd.	2,219	-	2,219
Structural Repair of Concrete (Depth Equal to or Less than 5 inches)	Sq. Ft.	20	5	25
Deck Slab Repair (Full Depth, Type I)	Sq. Yd.	3	-	3
Deck Slab Repair (Full Depth, Type II)	Sq. Yd.	2	-	2
Drainage Scuppers to be Adjusted	Each	4	-	4

MODEL: \$MODELNAME\$  
FILE NAME: \$FILES



QUIGG ENGINEERING INC

USER NAME = \$USER\$	DESIGNED - ZLD	REVISED -
\$FILE\$	CHECKED - RPW	REVISED -
PLOT SCALE = \$SCALE\$	DRAWN - JDC	REVISED -
PLOT DATE =	CHECKED - MDC	REVISED -

**STATE OF ILLINOIS  
DEPARTMENT OF TRANSPORTATION**

**GENERAL DATA  
STRUCTURE NO. 029-0056**

SHEET 2 OF 15 SHEETS

F.A.P. RTE.	SECTION	COUNTY	TOTAL SHEETS	SHEET NO.
30	[139,138(BC;BC-1)BR,BR-1]BRR	FULTON	119	93
			CONTRACT NO. 68H20	
		ILLINOIS	FED. AID PROJECT	

SDATE\$ \$TIME\$

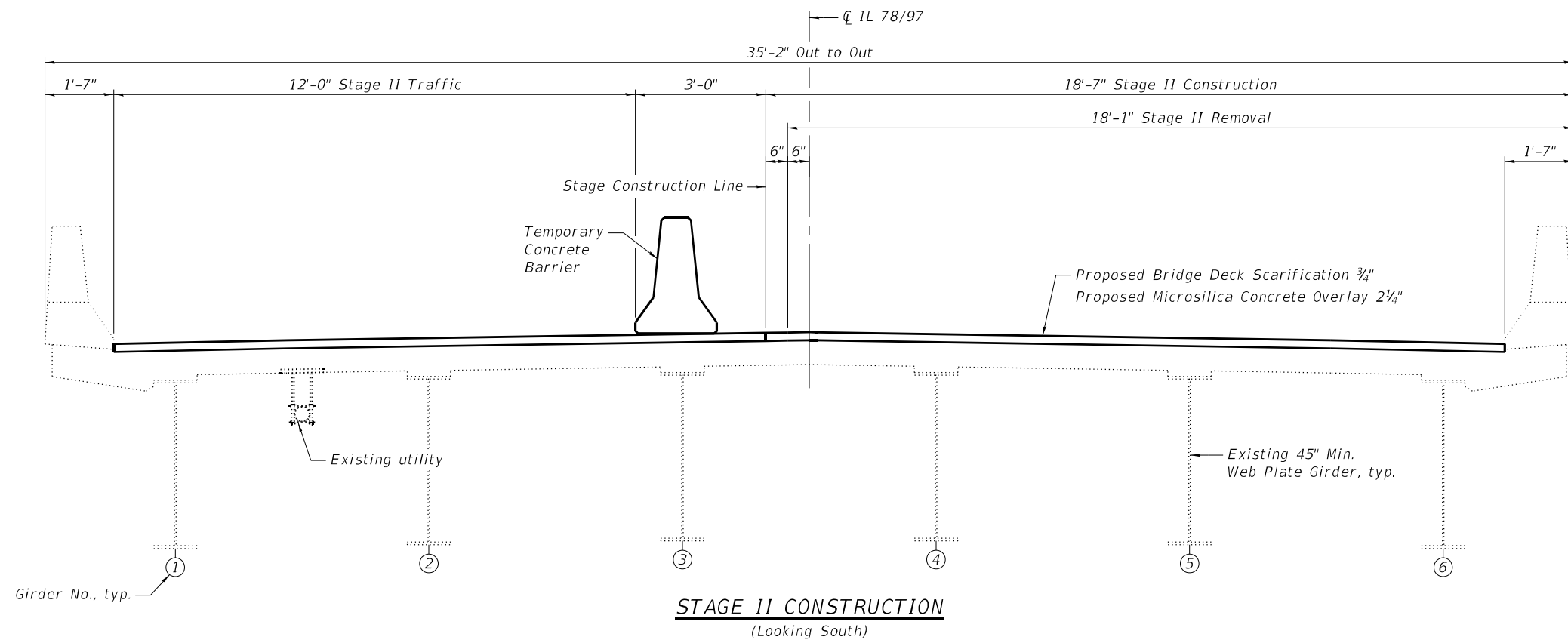
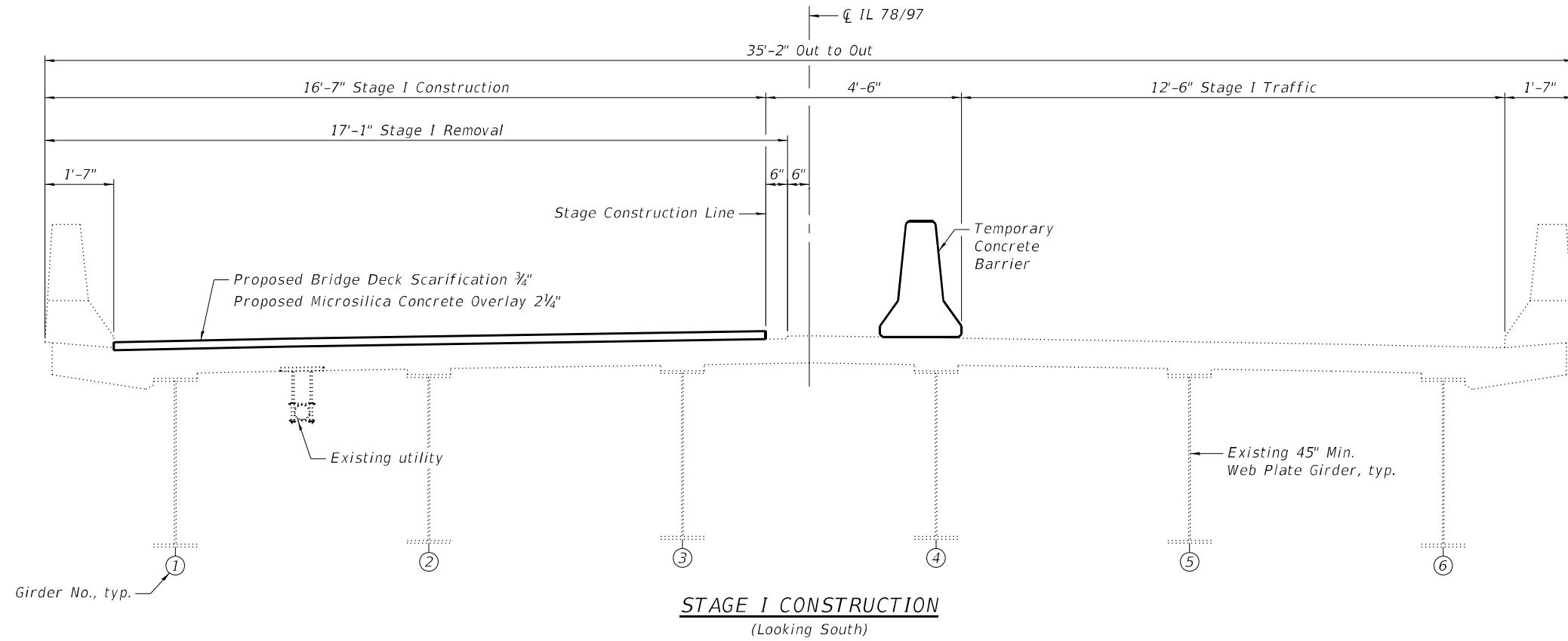

MODEL: \$MODELNAME\$  
FILE NAME: \$FILES



QUIGG ENGINEERING INC

USER NAME = \$USER\$	DESIGNED - ZLD	REVISED -
\$FILES\$	CHECKED - RPW	REVISED -
PLOT SCALE = \$SCALE\$	DRAWN - JDC	REVISED -
PLOT DATE =	CHECKED - MDC	REVISED -

**STATE OF ILLINOIS  
DEPARTMENT OF TRANSPORTATION**

**STAGE CONSTRUCTION DETAILS  
STRUCTURE NO. 029-0056**

SHEET 3 OF 15 SHEETS

F.A.P. RTE.	SECTION	COUNTY	TOTAL SHEETS	SHEET NO.
30	[139,138(BC;BC-1)BR,BR-1]BRR	FULTON	119	94
CONTRACT NO. 68H20				
		ILLINOIS	FED. AID PROJECT	

SDATE\$ \$TIME\$

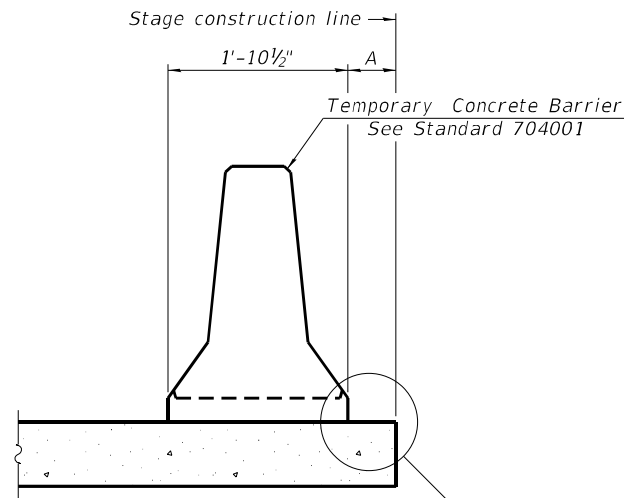

When "A" is 3'-1" or less, the temporary concrete barrier shall be restrained to the new slab according to Detail I, II or III. No restraint is required when "A" is greater than 3'-1".

**NEW SLAB OR NEW DECK BEAM**

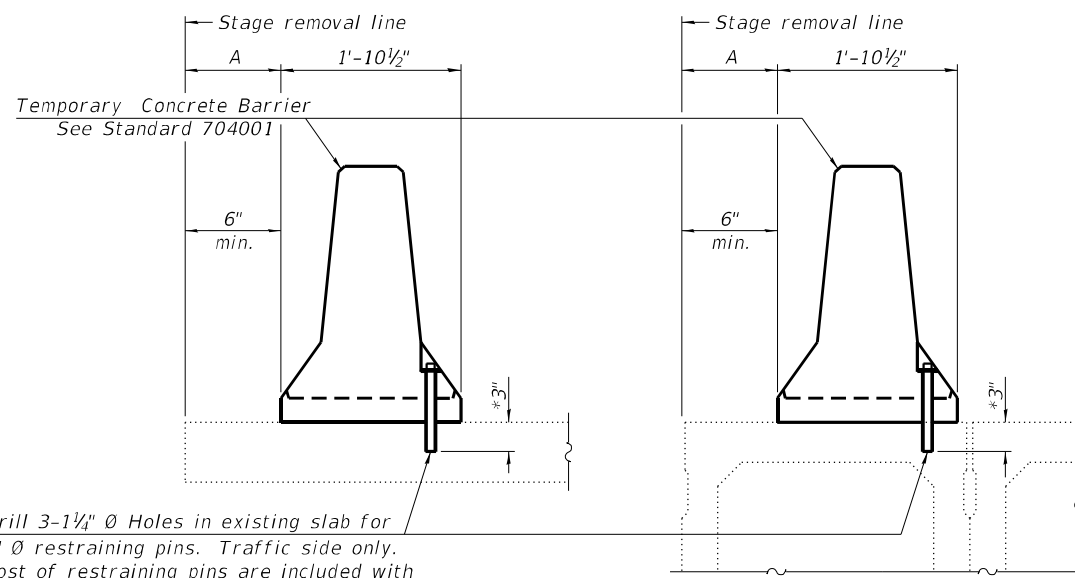

Drill 3-1/4" Ø Holes in existing slab for 1" Ø restraining pins. Traffic side only. Cost of restraining pins are included with Temporary Concrete Barrier. No restraint is required when "A" is greater than 3'-1".

**EXISTING SLAB**

\* When hot-mix asphalt wearing surface is present, embedment shall be 3" plus the wearing surface depth.

**EXISTING DECK BEAM**

**SECTIONS THRU SLAB OR DECK BEAM**

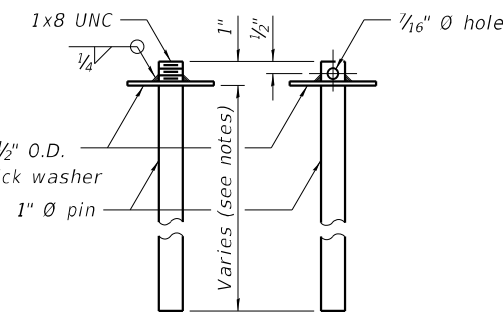

**RESTRAINING PIN**

US Std. 1 1/16" I.D. x 2 1/2" O.D. x approx. 8 gauge thick washer

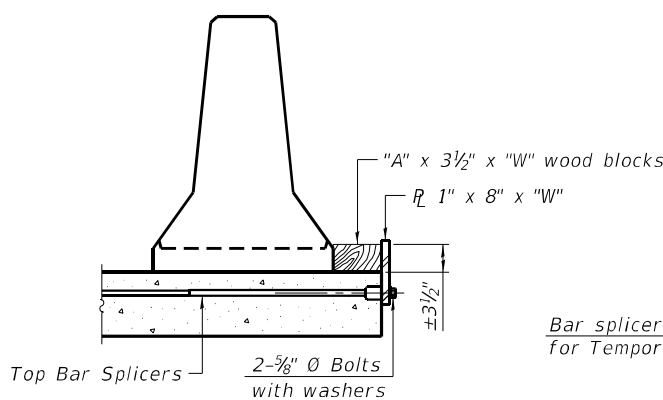

**DETAIL I**

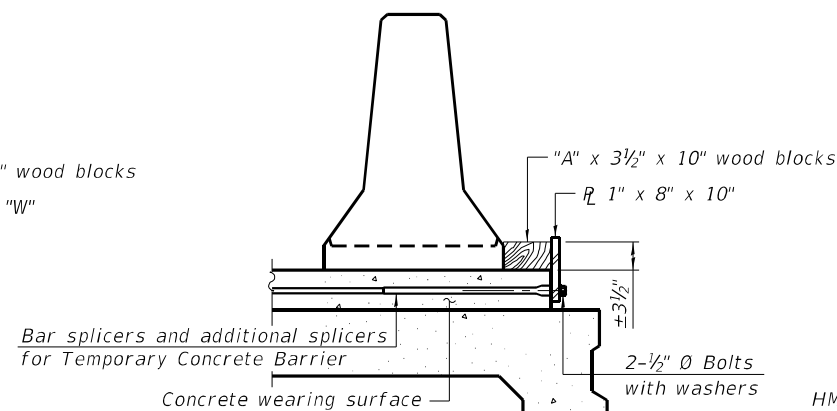

**DETAIL II**

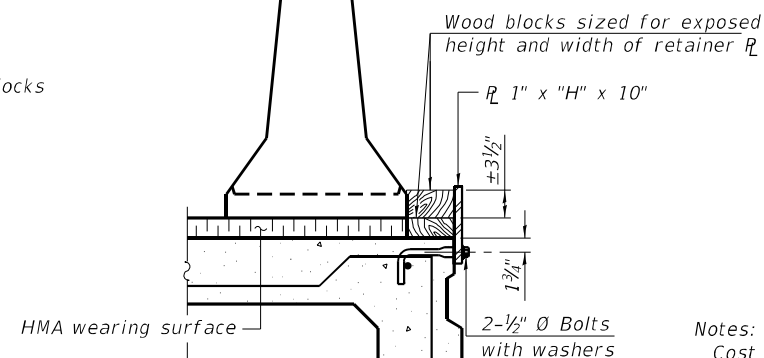

**DETAIL III**

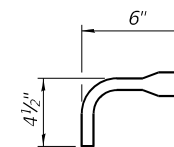

**BAR SPLICER FOR #4 BAR - DETAIL III**

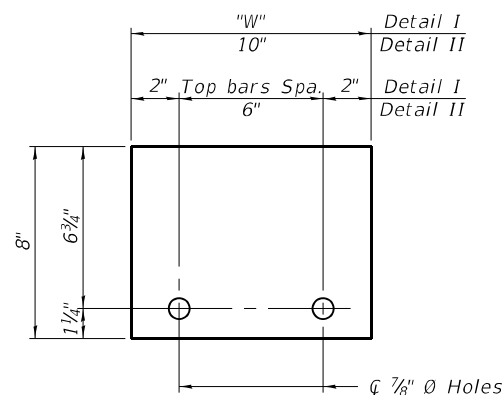

**STEEL RETAINER R 1" x 8" x "W"**  
(Detail I and II)

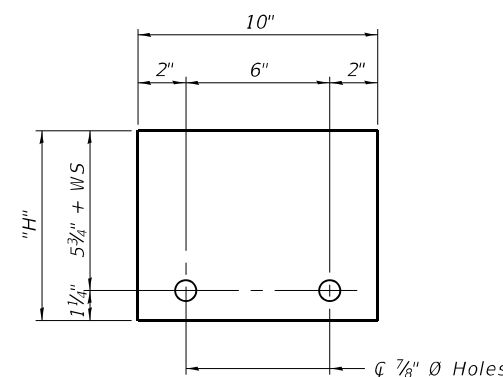

**STEEL RETAINER R 1" x "H" x 10"**  
(Detail III)

Notes:  
 Cost of retainer assembly is included with Temporary Concrete Barrier.  
 A retainer assembly shall be located at the approximate  $\bar{c}$  of each temporary concrete barrier.  
 The retainer plate shall not be removed until the concrete on the adjacent stage is ready to be poured. For Detail III applications the retainer plate shall not be removed until just prior to placing the adjacent beam.  
 When the 'A' dimension is less than 1 1/2', the wood block shall be omitted and the barrier shall be placed in direct contact with the steel retainer plate. For deck beam applications the minimum required 'A' distance is 6" to accommodate the shear key clamping device.

Detail I - Installation for a new bridge deck or bridge slab.  
 Detail II - Installation for a new deck beam with an initial concrete wearing surface. Additional bar splicers shall be provided at 6'-0" centers and paired with the bar splicers of the concrete wearing surface reinforcement to accommodate the installation of the retainer assemblies. The cost of the additional bar splicers is included with the concrete wearing surface.  
 Detail III - Installation for a new deck beam with no initial wearing surface or with an initial hot-mix asphalt (HMA) wearing surface present. The deck beam directly beneath the temporary concrete barrier shall be fabricated with bar splicer inserts in the side of the beam, as detailed, to accommodate the installation of the retainer assemblies. A pair of bar splicers, 6" apart, shall be placed at 6'-0" centers along the length of the beam. The cost of the bar splicers is included with the deck beam.

**RAILING CRITERIA**

NCHRP 350 Test Level	3
Railing Weight (plf)	440

R-27 10-12-2021

MODEL: SMODELNAMES  
FILE NAME: \$FILES



USER NAME = \$USERS\$	DESIGNED - ZLD	REVISED -
\$FILES\$	CHECKED - RPW	REVISED -
PLOT SCALE = \$SCALE\$	DRAWN - JDC	REVISED -
PLOT DATE =	CHECKED - MDC	REVISED -

STATE OF ILLINOIS  
DEPARTMENT OF TRANSPORTATION

TEMPORARY CONCRETE BARRIER  
STRUCTURE NO. 029-0056

SHEET 4 OF 15 SHEETS

F.A.P. RTE.	SECTION	COUNTY	TOTAL SHEETS	SHEET NO.
30	[139,138/BC/BC-1]BR, BR-1]BRR	FULTON	119	95
CONTRACT NO. 68H20				
ILLINOIS FED. AID PROJECT				

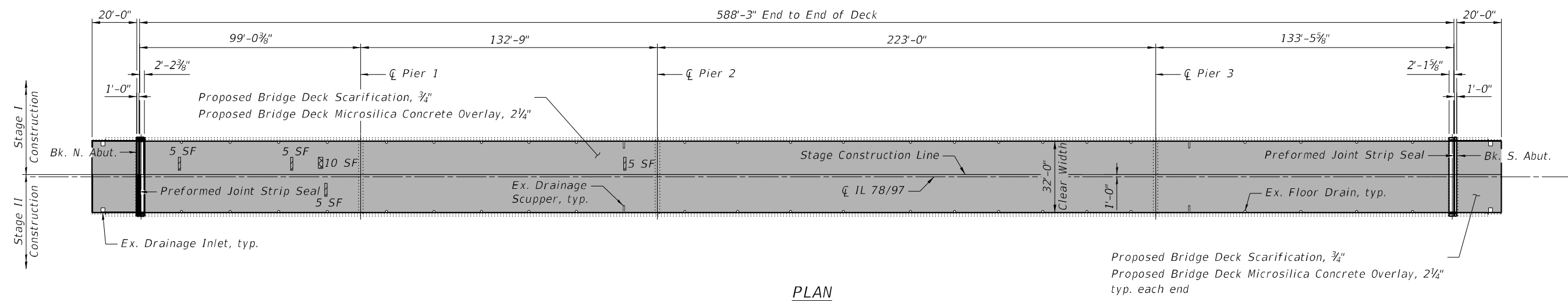
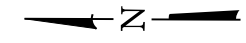

**PLAN**

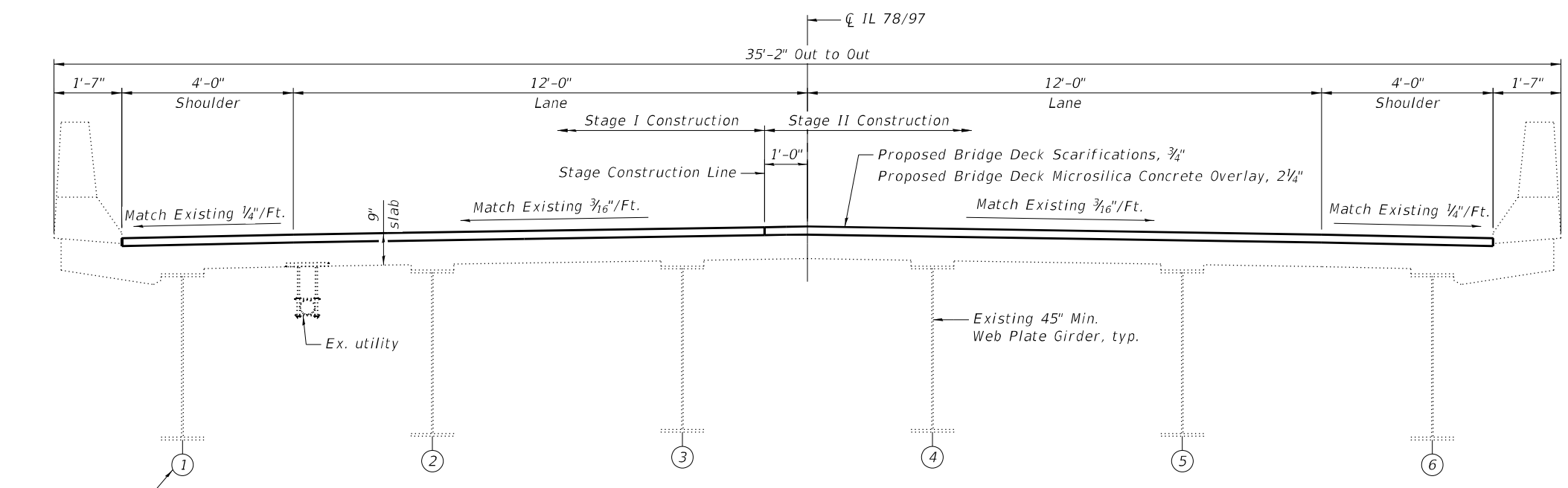

**CROSS SECTION**  
(Looking South)

**LEGEND**

- Deck Slab Repair (Full Depth, Type I)
- Deck Slab Repair (Full Depth, Type II)
- Scarification and Microsilica Concrete Overlay Limits

**Notes:**  
 See sheet 6 of 15 for overlay details at drainage scupper and drain pipes.  
 See sheets 8 thru 10 of 15 for expansion joint replacement details.  
 Deck Slab Repair (Full Depth, Type I) and Deck Slab Repair (Full Depth, Type II) areas are estimated and will be field verified by the Engineer prior to patching. The Engineer shall show actual locations of deck repairs on as-built plans.

**TOTAL BILL OF MATERIAL**

ITEM	UNIT	TOTAL
Bridge Deck Grooving	Sq. Yd.	2,101
Protective Coat	Sq. Yd.	2,246
Bridge Deck Scarification 3/4"	Sq. Yd.	2,219
Bridge Deck Microsilica Concrete Overlay 2 1/4"	Sq. Yd.	2,219
Deck Slab Repair (Full Depth, Type I)	Sq. Yd.	3
Deck Slab Repair (Full Depth, Type II)	Sq. Yd.	2

MODEL: \$MODELNAME\$  
FILE NAME: \$FILES



USER NAME = \$USERS\$	DESIGNED - ZLD	REVISED -
\$FILES\$	CHECKED - RPW	REVISED -
PLOT SCALE = \$SCALE\$	DRAWN - JDC	REVISED -
PLOT DATE =	CHECKED - MDC	REVISED -

**STATE OF ILLINOIS**  
**DEPARTMENT OF TRANSPORTATION**

**DECK OVERLAY PLAN**  
**STRUCTURE NO. 029-0056**

SHEET 5 OF 15 SHEETS

F.A.P. RTE.	SECTION	COUNTY	TOTAL SHEETS	SHEET NO.
30	[139,138(BC;BC-1)BR,BR-1]BRR	FULTON	119	96
CONTRACT NO. 68H20				
ILLINOIS FED. AID PROJECT				



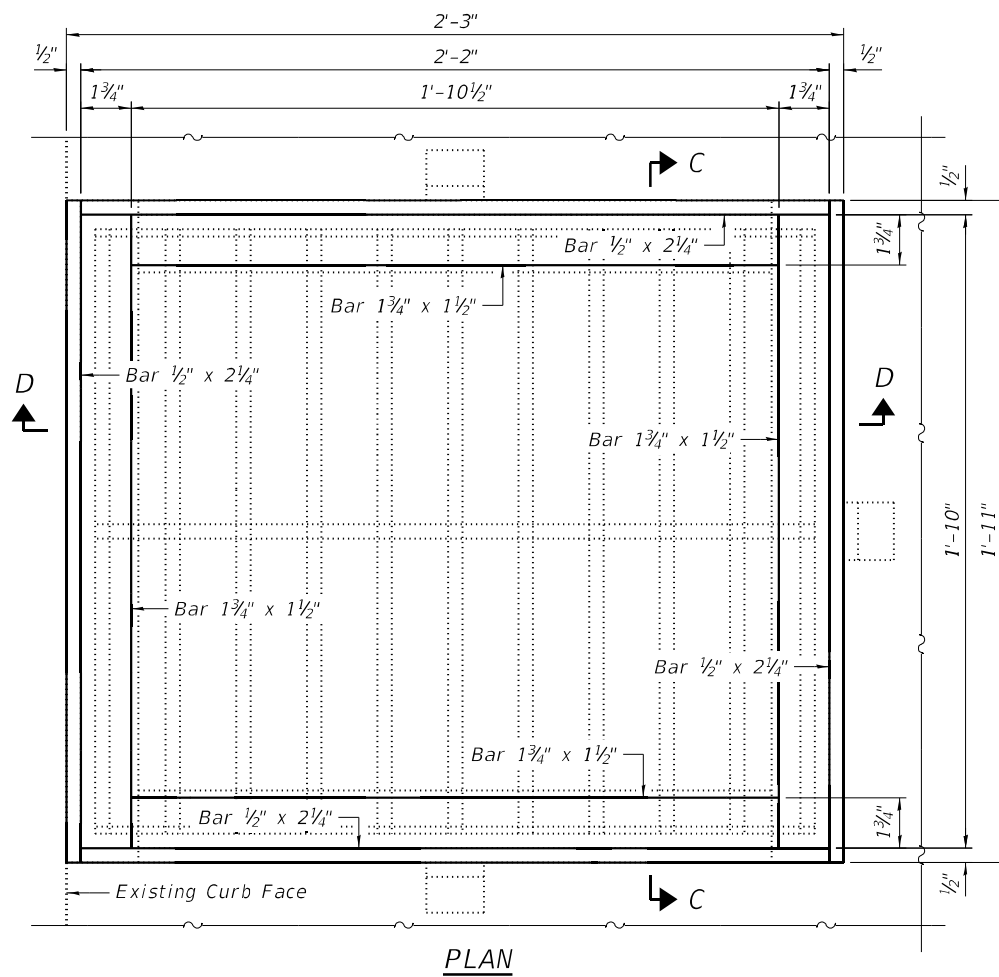

PLAN

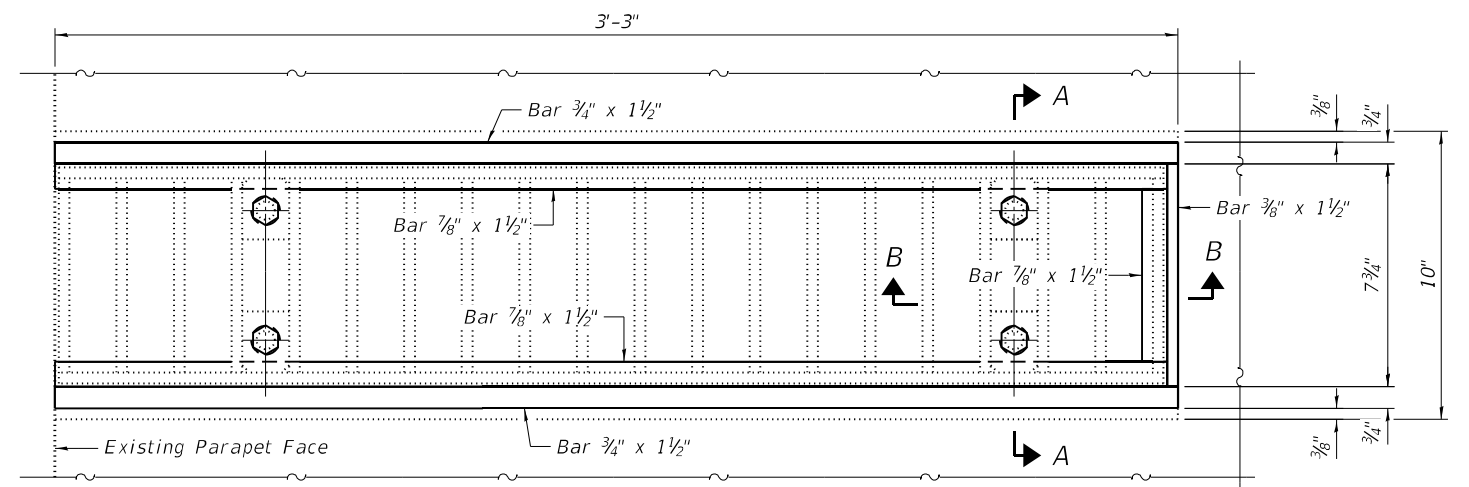

PLAN

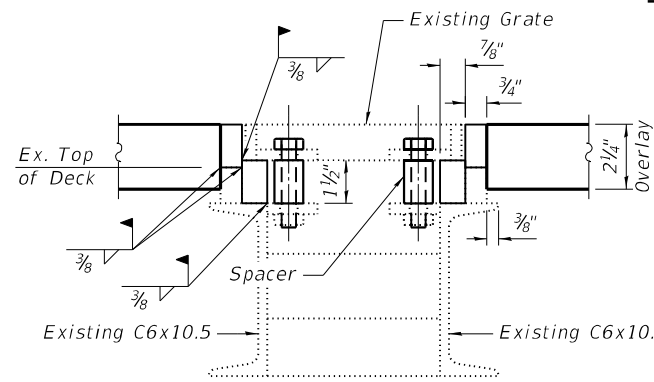

SECTION A-A

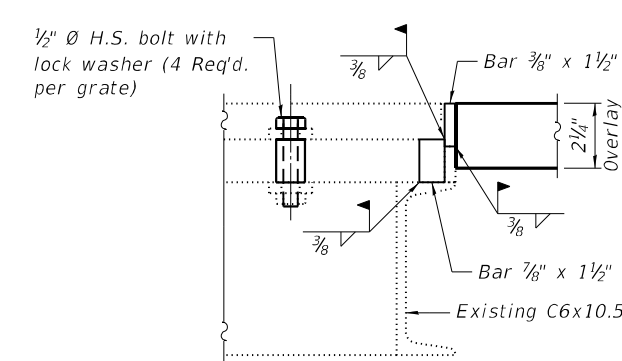

SECTION B-B

DRAINAGE SCUPPER ADJUSTING RING DETAILS

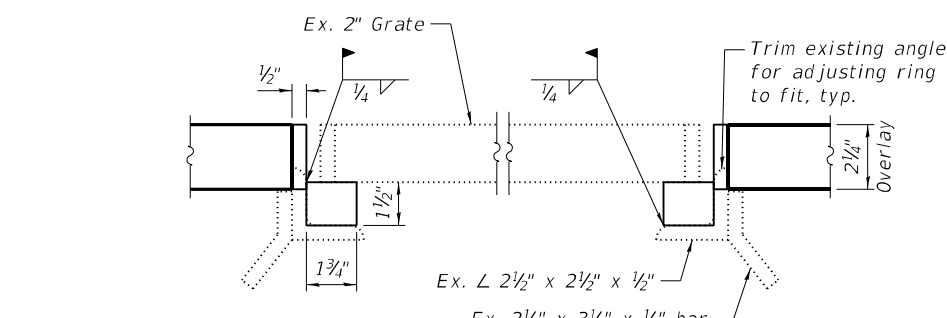

SECTION C-C

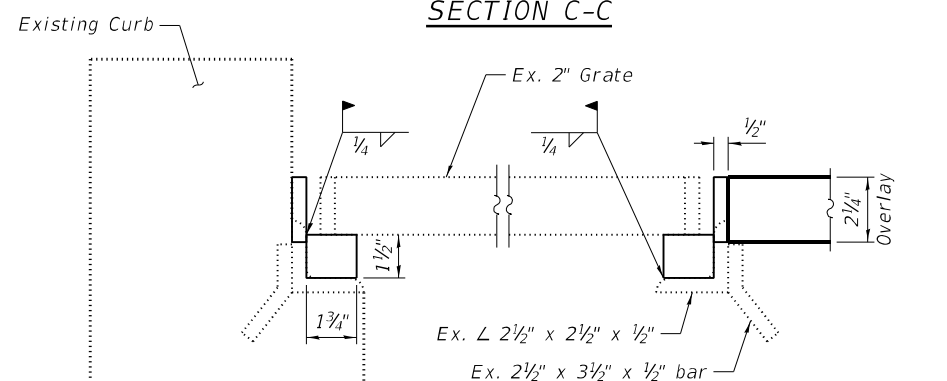

SECTION D-D

SHOULDER INLET ADJUSTING RING DETAILS

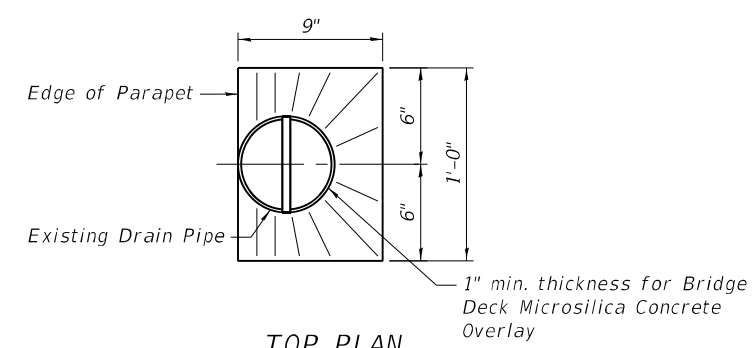

TOP PLAN

Overlay Transition at 6" Ø Drain Pipes

Notes:  
 All structural steel shall conform to AASHTO M270 Grade 36. The adjusting inlet ring and adjusting scupper ring shall be galvanized.  
 Bolts shall be 1/2" Ø, AASHTO M164 Type 1, mechanically galvanized.  
 The Contractor shall ensure that no damage is done to the existing grates that are to be reused.  
 Shop plans for the proposed adjusting scupper ring shall be submitted for approval prior to fabrication.  
 Cost of all labor and materials necessary to remove existing grates, clean existing scuppers, install adjusting scupper rings and reinstall grates is included in the cost per unit each for Drainage Scuppers to be Adjusted.  
 Shop plans for proposed adjusting inlet ring shall be submitted for approval prior to fabrication.  
 Cost of all labor and materials necessary to remove existing grates, clean existing inlets, install adjusting inlet rings and reinstall grates is included in the cost per unit each for Inlets to be Adjusted.

BILL OF MATERIAL

Item	Unit	Total
Inlets to be Adjusted	Each	4
Drainage Scuppers to be Adjusted	Each	4

MODEL: SMODELNAMES  
 FILE NAME: \$FILES



USER NAME = \$USERS\$	DESIGNED - ZLD	REVISED -
\$FILES\$	CHECKED - RPW	REVISED -
PLOT SCALE = \$SCALE\$	DRAWN - JDC	REVISED -
PLOT DATE =	CHECKED - MDC	REVISED -

STATE OF ILLINOIS  
 DEPARTMENT OF TRANSPORTATION

DRAIN ADJUSTING DETAILS  
 STRUCTURE NO. 029-0056

SHEET 6 OF 15 SHEETS

F.A.P. RTE.	SECTION	COUNTY	TOTAL SHEETS	SHEET NO.
30	[139,138(BC;BC-1)BR,BR-1]BRR	FULTON	119	97
CONTRACT NO. 68H20				
ILLINOIS FED. AID PROJECT				

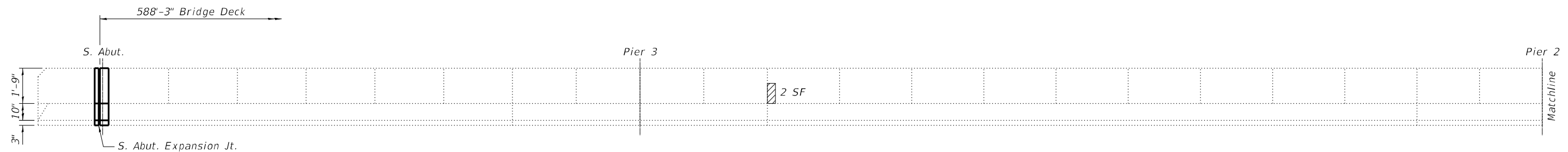

INSIDE FACE OF WEST PARAPET  
(Looking West)

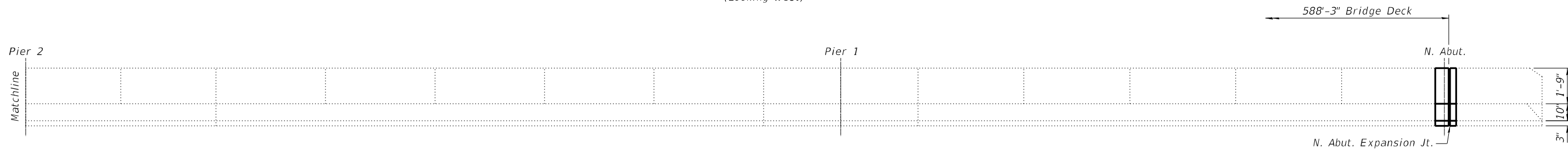

INSIDE FACE OF WEST PARAPET  
(Looking West)

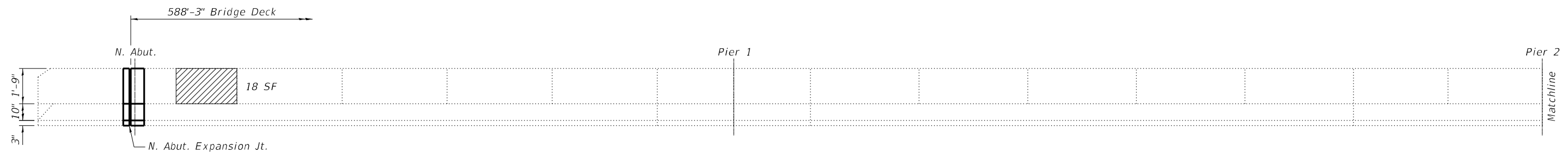

INSIDE FACE OF EAST PARAPET  
(Looking East)

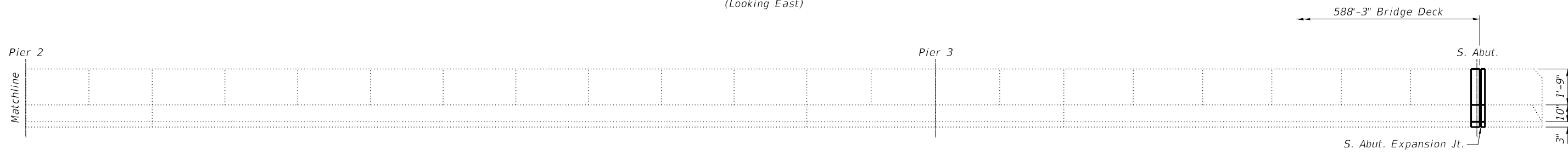

INSIDE FACE OF EAST PARAPET  
(Looking East)

**LEGEND**

Structural Repair of Concrete (Depth Equal to or less than 5")

Note:  
For expansion joint details, see sheets  
8 thru 10 of 15.

**BILL OF MATERIAL**

Item	Unit	Total
Structural Repair of Concrete (Depth Equal to or less than 5")	Sq. Ft.	20

MODEL: \$MODELNAME\$  
FILE NAME: \$FILES



QUIGG ENGINEERING INC

USER NAME = \$USER\$	DESIGNED - ZLD	REVISED -
\$FILE\$	CHECKED - RPW	REVISED -
PLOT SCALE = \$SCALE\$	DRAWN - JDC	REVISED -
PLOT DATE =	CHECKED - MDC	REVISED -

STATE OF ILLINOIS  
DEPARTMENT OF TRANSPORTATION

PARAPET REPAIRS  
STRUCTURE NO. 029-0056

SHEET 7 OF 15 SHEETS

F.A.P. RTE.	SECTION	COUNTY	TOTAL SHEETS	SHEET NO.
30	[139,138(BC;BC-1)BR,BR-1]BRR	FULTON	119	98
CONTRACT NO. 68H20				
ILLINOIS FED. AID PROJECT				

SDATE\$ \$TIME\$

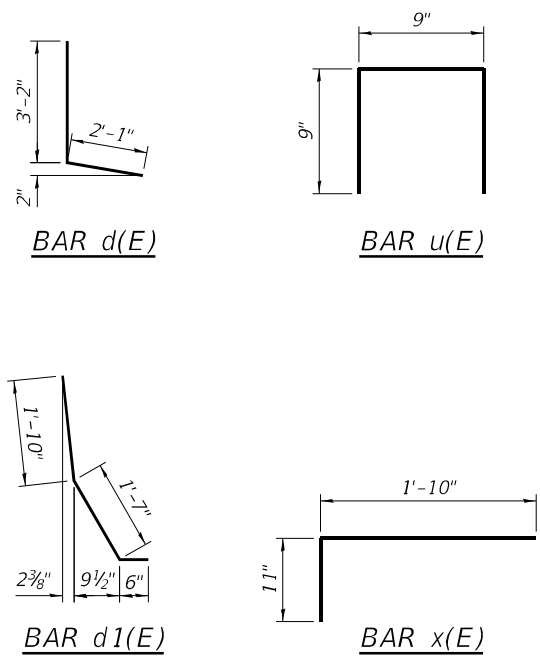
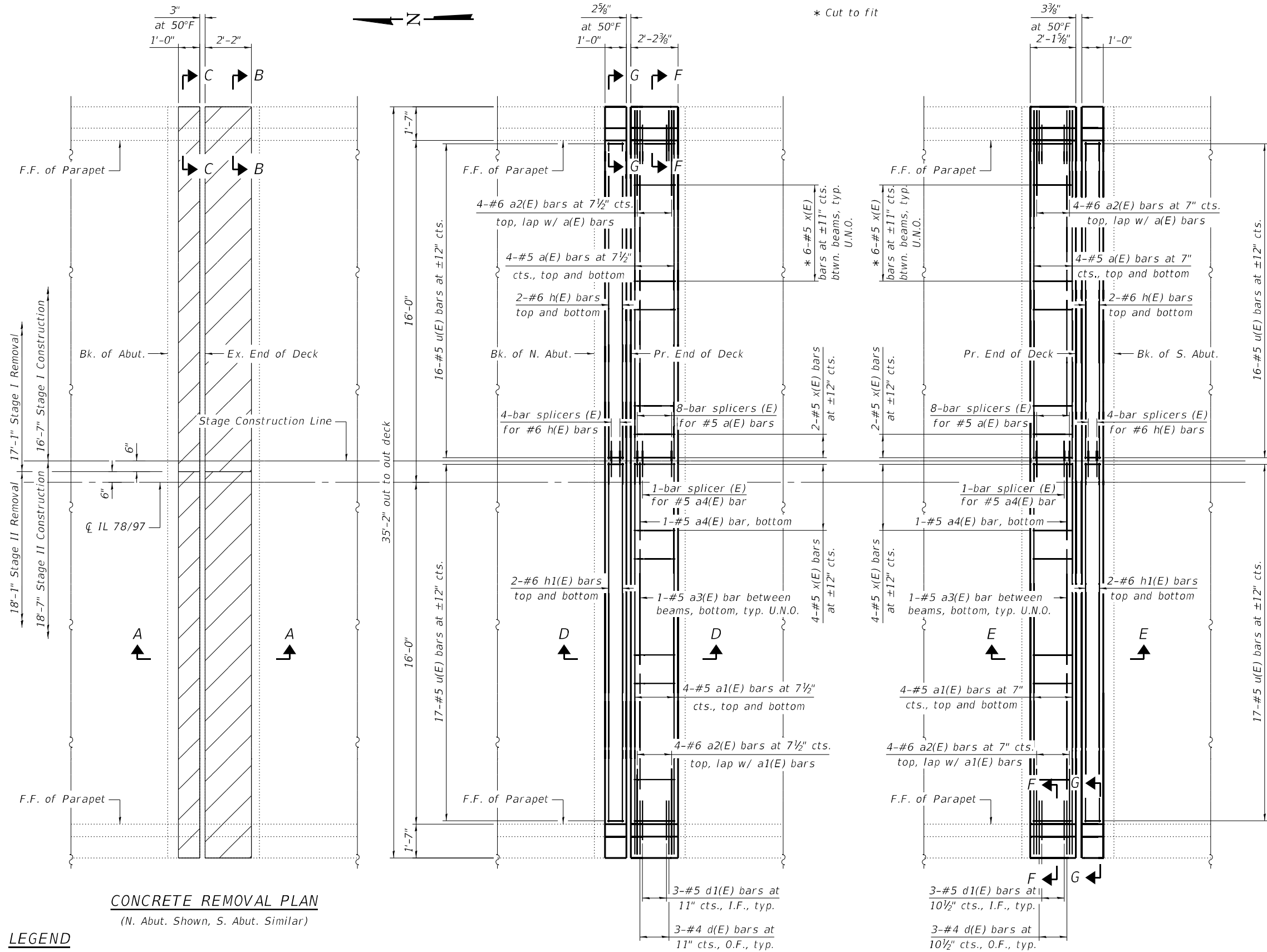

**Notes:**  
 Any reinforcement bars that are to remain that are damaged during concrete removal operations shall be repaired or replaced using an approved bar splicer or anchorage system. Cost included with Concrete Removal.  
 Existing longitudinal and vertical reinforcement bars remaining and extending into the removal areas shall be cleaned, straightened and incorporated into the new construction. Cost included with Concrete Removal.  
 See sheet 9 of 15 for sections.  
 See sheet 5 of 15 for overlay details.  
 See sheet 10 of 15 for joint seal details.

**BILL OF MATERIAL**

Bar	No.	Size	Length	Shape	
a(E)	16	#5	16'-0"	—	
a1(E)	16	#5	18'-0"	—	
a2(E)	16	#6	7'-4"	—	
a3(E)	8	#5	5'-5"	—	
a4(E)	2	#5	3'-7"	—	
d(E)	12	#4	5'-3"	L	
d1(E)	12	#5	3'-11"	∩	
h(E)	8	#6	14'-8"	—	
h1(E)	8	#6	16'-8"	—	
u(E)	66	#5	2'-3"	⊏	
x(E)	60	#5	2'-9"	└	
Item				Unit	Total
Concrete Removal				Cu. Yd.	10.5
Concrete Superstructure				Cu. Yd.	11.4
Reinforcement Bars, Epoxy Coated				Pound	1,600

**CONCRETE REMOVAL PLAN**  
 (N. Abut. Shown, S. Abut. Similar)

**LEGEND**



**CONCRETE REPLACEMENT PLAN**

MODEL: SMODELNAMES  
 FILE NAME: \$FILES



USER NAME = \$USERS\$	DESIGNED - ZLD	REVISED -
\$FILES\$	CHECKED - RPW	REVISED -
PLOT SCALE = \$SCALE\$	DRAWN - JDC	REVISED -
PLOT DATE =	CHECKED - MDC	REVISED -

**STATE OF ILLINOIS  
 DEPARTMENT OF TRANSPORTATION**

**EXPANSION JOINT DETAILS  
 STRUCTURE NO. 029-0056**

SHEET 8 OF 15 SHEETS

F.A.P. RTE.	SECTION	COUNTY	TOTAL SHEETS	SHEET NO.
30	[139,138/BC/BC-1]BR, BR-1]BR	FULTON	119	99
CONTRACT NO. 68H20				
ILLINOIS FED. AID PROJECT				

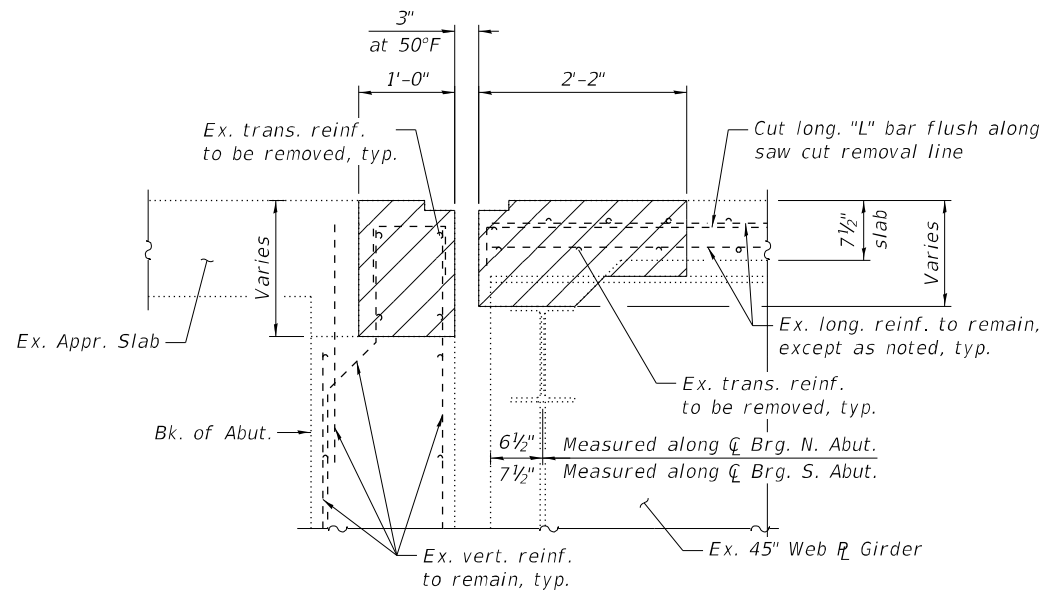

SECTION A-A

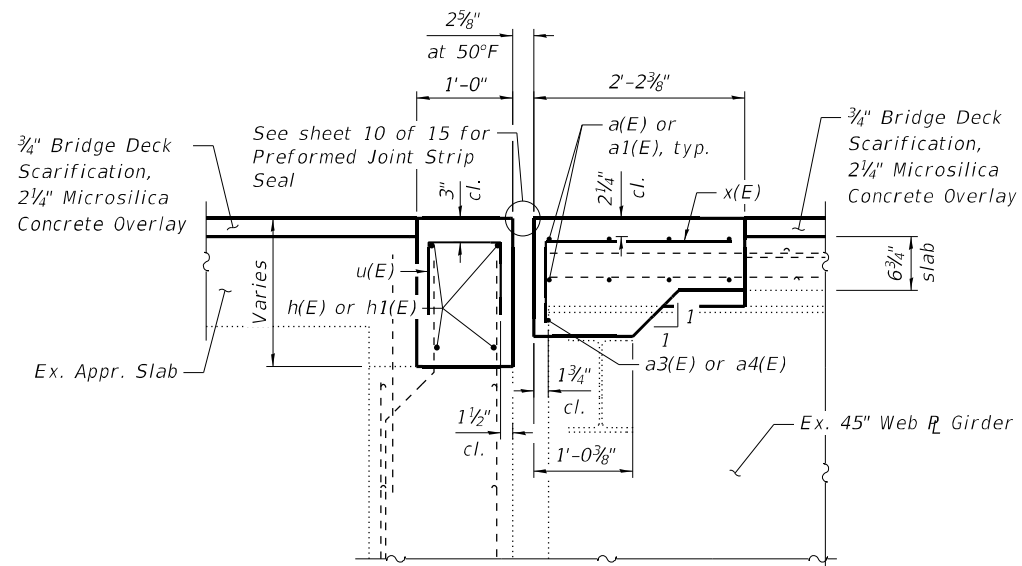

SECTION D-D

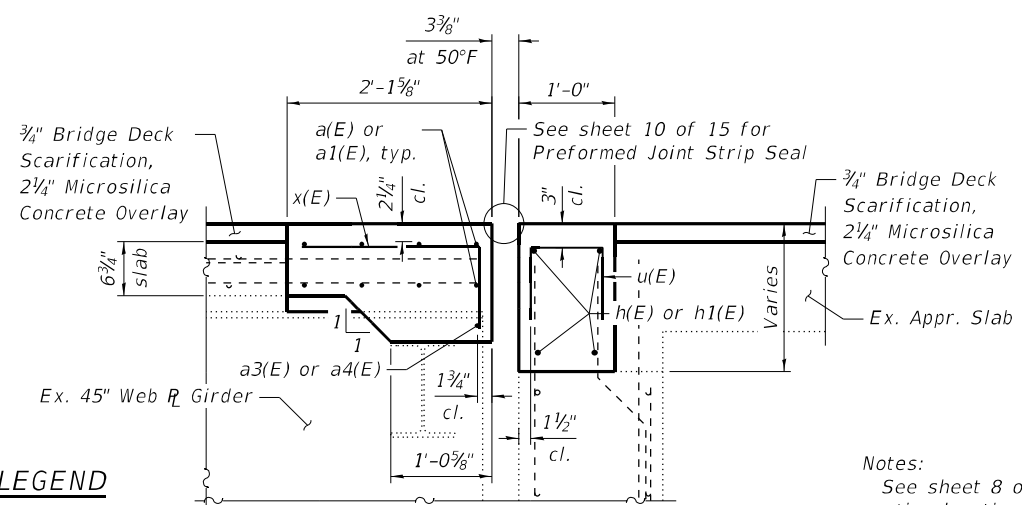

SECTION E-E

LEGEND

Concrete Removal

Notes:  
See sheet 8 of 15 for Bill of Material, section locations and additional details.  
See sheet 5 of 15 for overlay details.

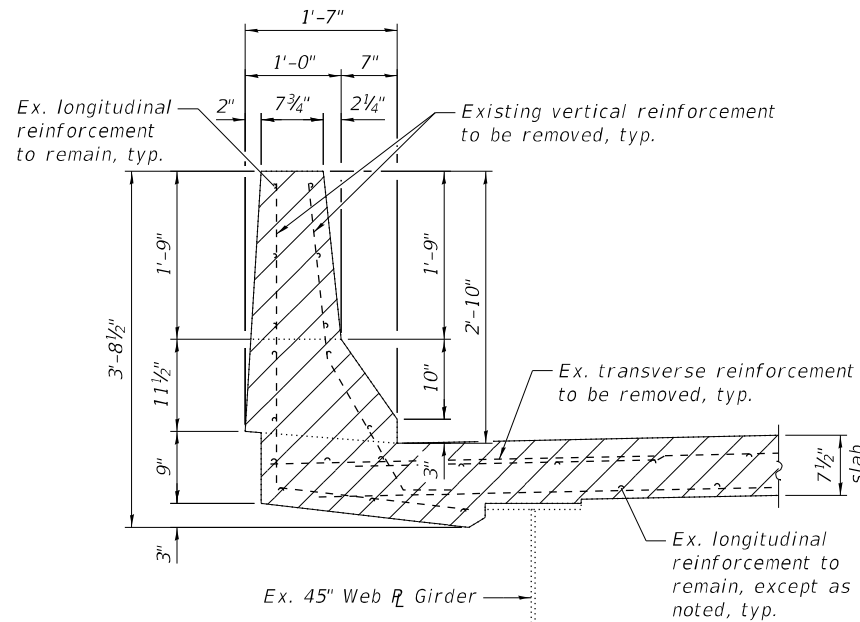

SECTION B-B

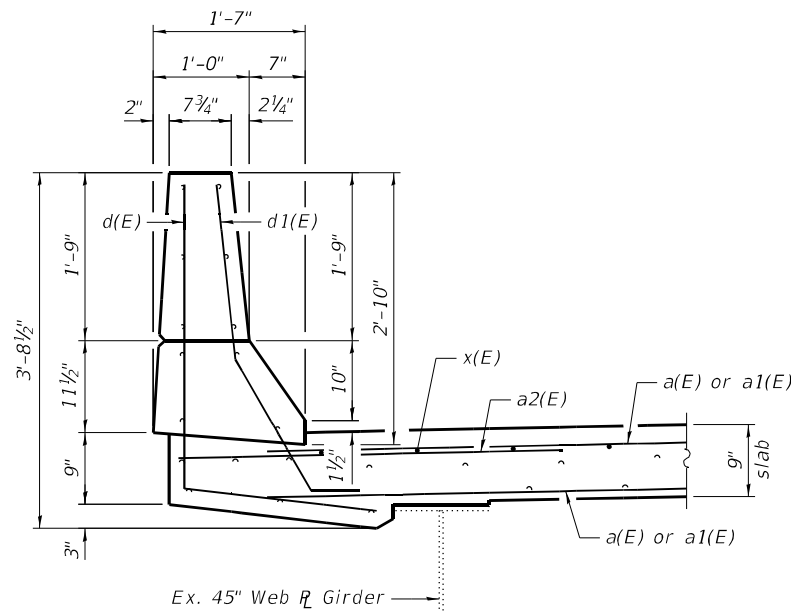

SECTION F-F

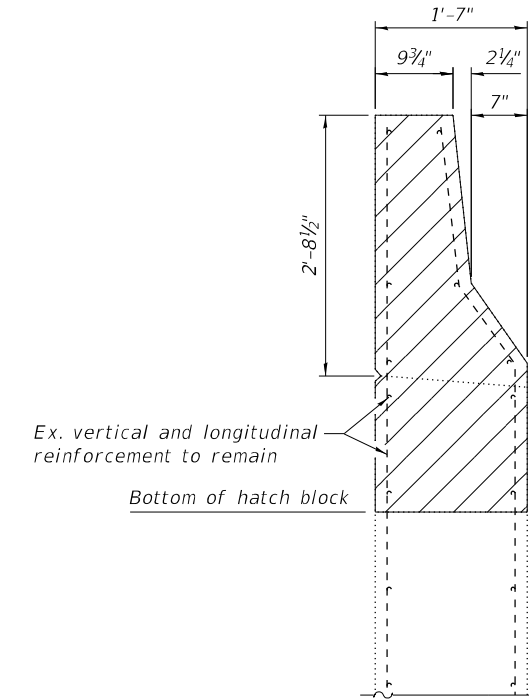

SECTION C-C

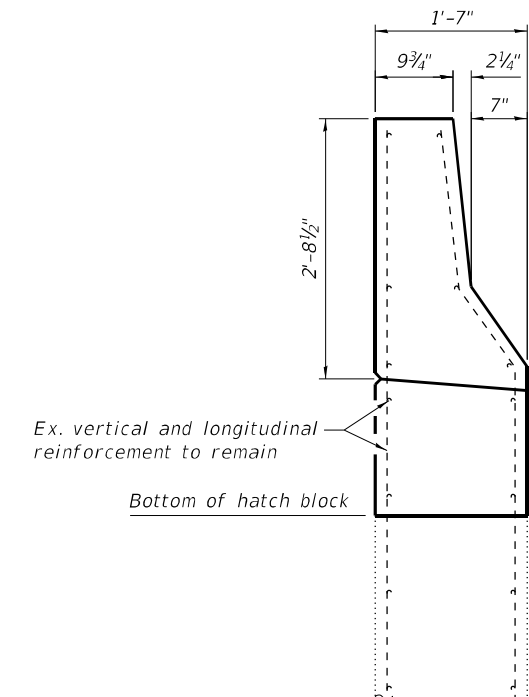

SECTION G-G

MODEL: SMODELNAMES  
FILE NAME: \$FILES



QUIGG ENGINEERING INC

USER NAME = \$USERS\$	DESIGNED - ZLD	REVISED -
\$FILES\$	CHECKED - RPW	REVISED -
PLOT SCALE = \$SCALE\$	DRAWN - JDC	REVISED -
PLOT DATE =	CHECKED - MDC	REVISED -

STATE OF ILLINOIS  
DEPARTMENT OF TRANSPORTATION

EXPANSION JOINT DETAILS  
STRUCTURE NO. 029-0056

SHEET 9 OF 15 SHEETS

F.A.P. RTE.	SECTION	COUNTY	TOTAL SHEETS	SHEET NO.
30	[139,138(BC;BC-1)BR,BR-1]BRR	FULTON	119	100
CONTRACT NO. 68H20				
ILLINOIS FED. AID PROJECT				

\$DATE\$ \$TIME\$

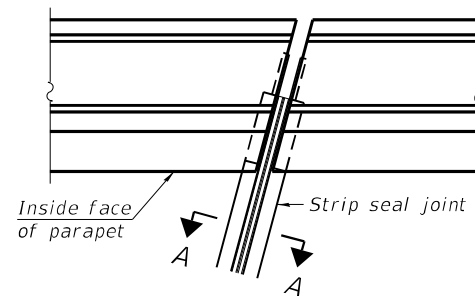

FOR SKEWS  $\leq 30^\circ$

PLAN AT PARAPET

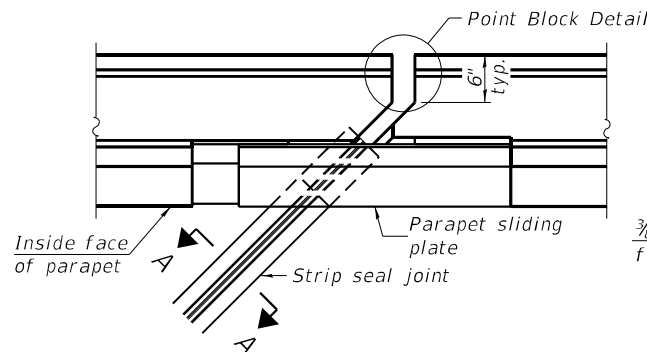

FOR SKEWS  $> 30^\circ$

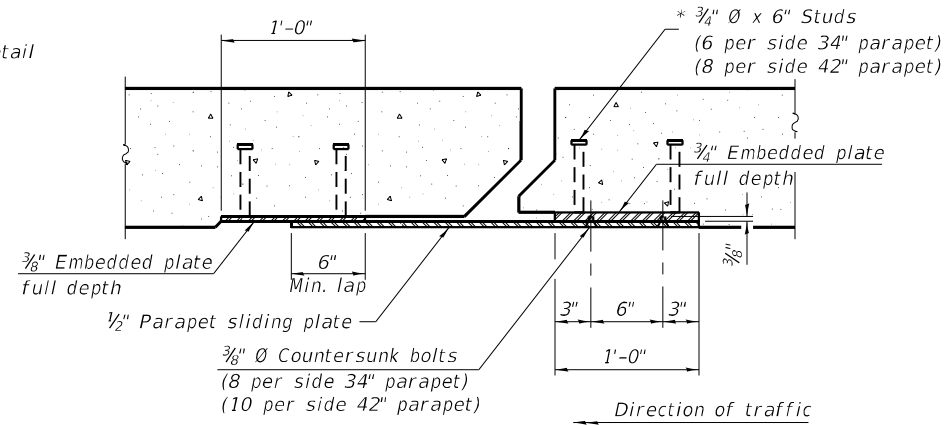

SECTION B-B

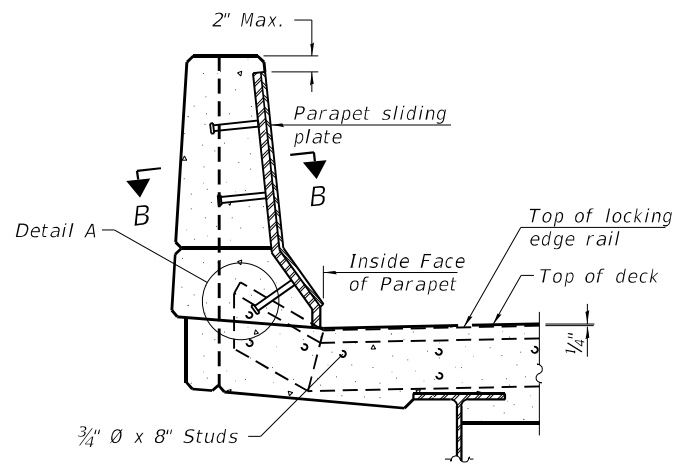

ELEVATION AT PARAPET

(Skews  $> 30^\circ$  shown. Skews  $\leq 30^\circ$  similar except as shown in plan view.)

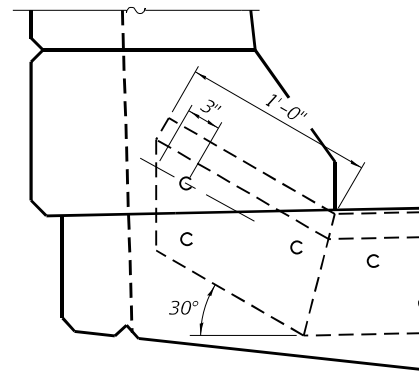

DETAIL A

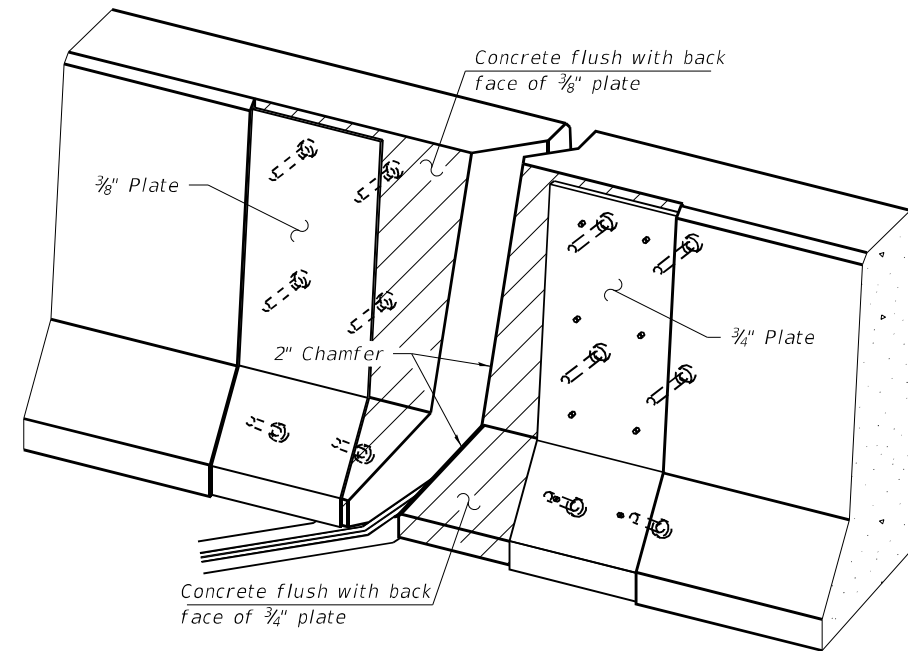

TRIMETRIC VIEW  
(Showing embedded plates only)

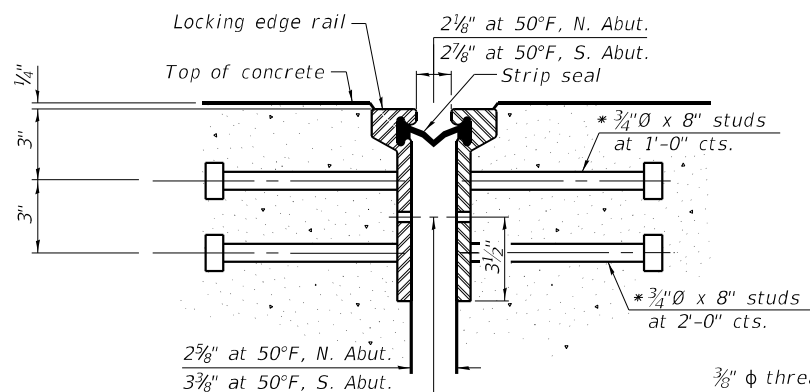

SHOWING ROLLED RAIL JOINT

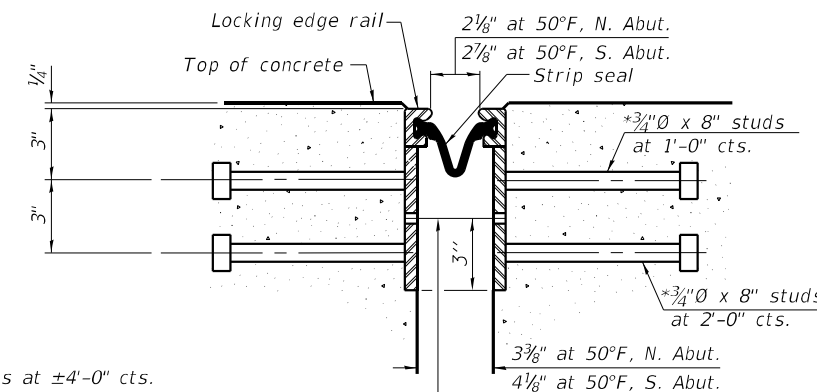

SHOWING WELDED RAIL JOINT

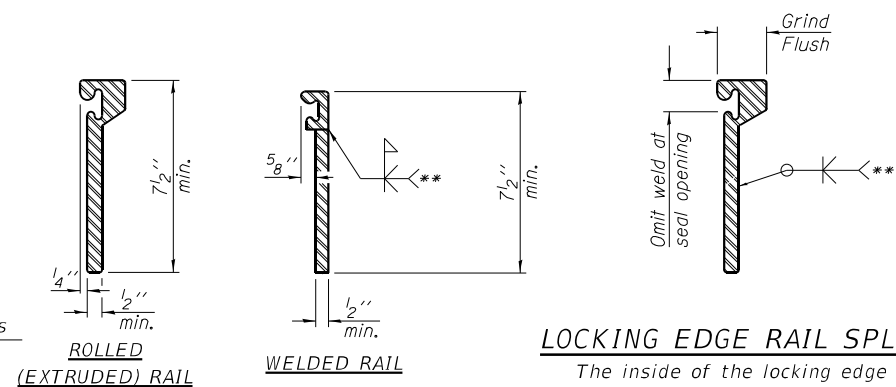

LOCKING EDGE RAILS

\*\* Back gouge not required if complete joint penetration is verified by mock-up.

LOCKING EDGE RAIL SPLICE

The inside of the locking edge rail groove shall be free of weld residue. Rolled rail shown, welded rail similar.

BILL OF MATERIAL

Item	Unit	Total
Preformed Joint Strip Seal	Foot	68

MODEL: SMODELNAMES  
FILE NAME: \$FILES

EJ-SS (TALL WITH GUTTER)

10-1-19



USER NAME =	\$USERS\$	DESIGNED -	ZLD	REVISED -	
\$FILES\$		CHECKED -	RPW	REVISED -	
PLOT SCALE =	\$SCALE\$	DRAWN -	JDC	REVISED -	
PLOT DATE =		CHECKED -	MDC	REVISED -	

DESIGNED -	ZLD	REVISED -	
CHECKED -	RPW	REVISED -	
DRAWN -	JDC	REVISED -	
CHECKED -	MDC	REVISED -	

STATE OF ILLINOIS  
DEPARTMENT OF TRANSPORTATION

PREFORMED JOINT STRIP SEAL  
STRUCTURE NO. 029-0056

SHEET 10 OF 15 SHEETS

F.A.P. RTE.	SECTION	COUNTY	TOTAL SHEETS	SHEET NO.
30	[139,138;BC;BC-1]BR, BR-1]BRR	FULTON	119	101
CONTRACT NO. 68H20				
ILLINOIS FED. AID PROJECT				

SDATE\$ STIME\$

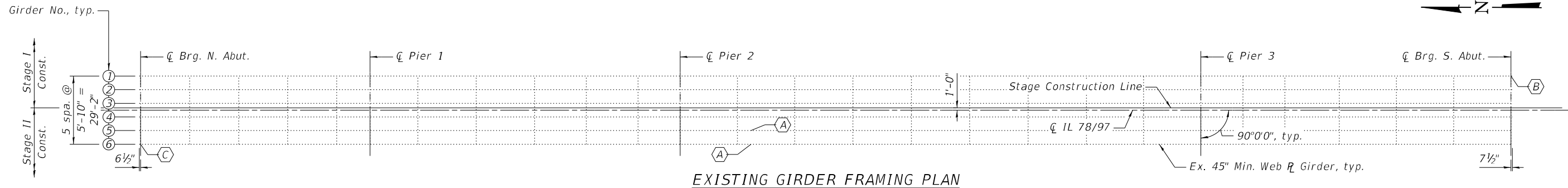
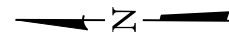

**EXISTING GIRDER FRAMING PLAN**

- Ⓐ - Girder Repair "A"
- Ⓑ - Girder End Repair "B"
- Ⓒ - Girder End Repair "C"

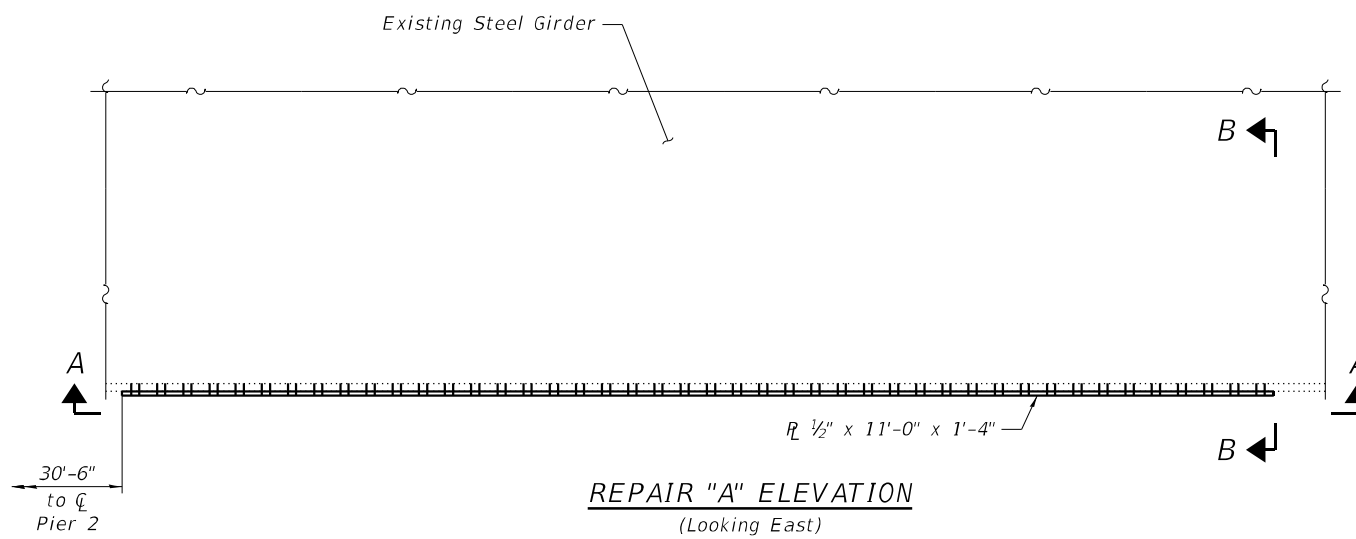
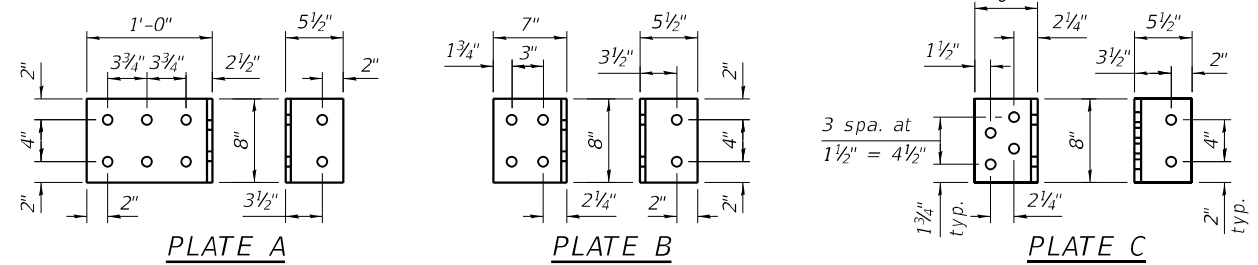

**REPAIR "A" ELEVATION**  
(Looking East)

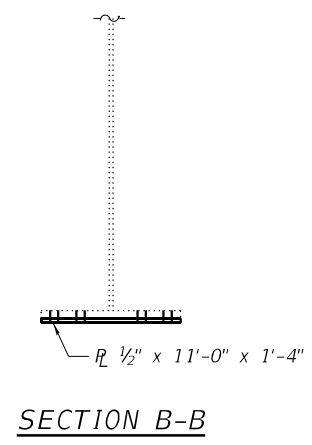

**SECTION B-B**

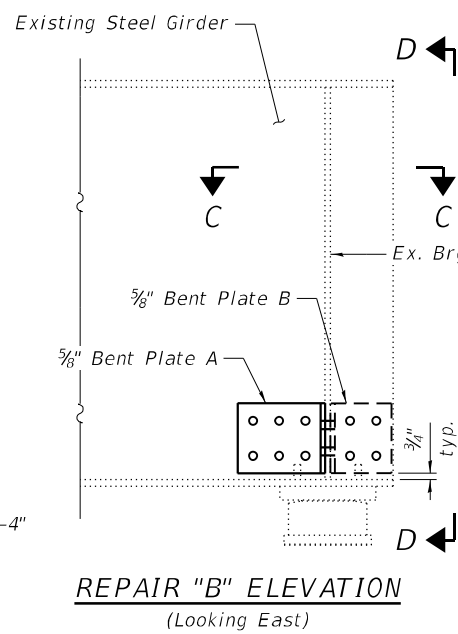

**REPAIR "B" ELEVATION**  
(Looking East)

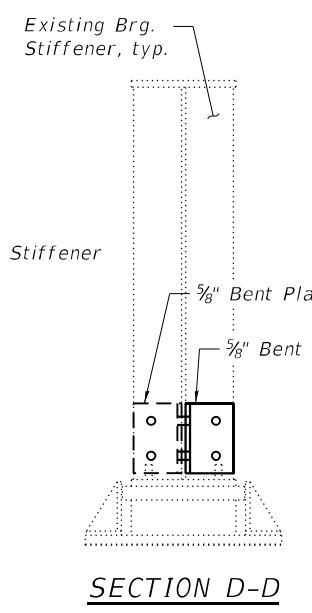

**SECTION D-D**

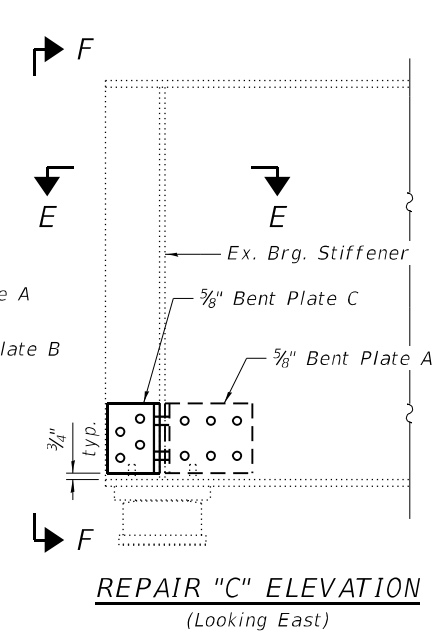

**REPAIR "C" ELEVATION**  
(Looking East)

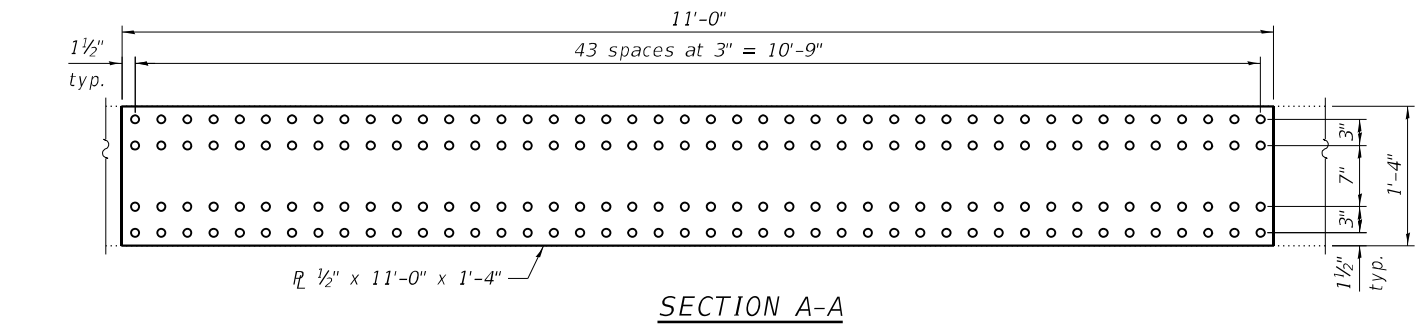

**SECTION A-A**

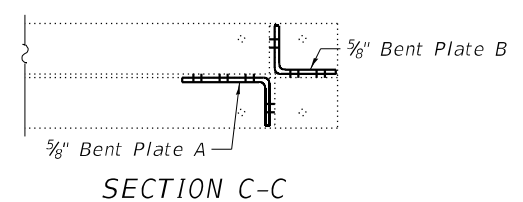

**SECTION C-C**

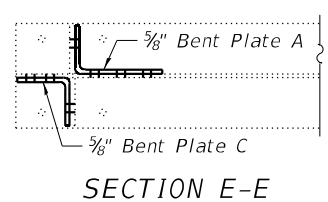

**SECTION E-E**

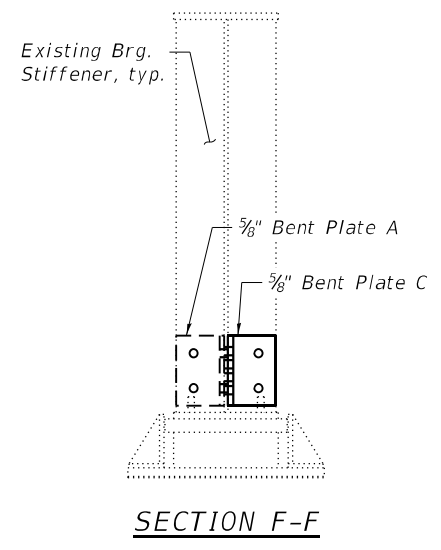

**SECTION F-F**

**Notes:**  
 Field drill  $1\frac{3}{16}$ "  $\emptyset$  holes for  $\frac{3}{4}$ "  $\emptyset$  bolts into existing girder. Use holes in new steel as template to field drill holes in existing steel.  
 All structural steel shall be AASHTO M270 Grade 50, unless otherwise noted.  
 Fasteners shall be ASTM A325 Type 1, mechanically galvanized bolts. Bolts  $\frac{3}{4}$ "  $\emptyset$ , holes  $1\frac{3}{16}$ "  $\emptyset$ , unless otherwise noted.  
 All repair materials including structural steel plates, bolts, nuts and washers shall be galvanized per the special provision "Hot Dip Galvanizing for Structural Steel". Cost included in Structural Steel Repair.  
 Existing structural steel that will be in contact with new structural steel shall be cleaned and painted prior to erection as required by the special provision "Cleaning and Painting Contact Surface Areas of Existing Steel Structures". Cost included in Structural Steel Repair.

**BILL OF MATERIAL**

Item	Unit	Total
Structural Steel Repair	Pound	960

MODEL: Default  
 FILE NAME: S:\2023\231006 PTB 206-30 D4 - Hurst, Rosche - Various PH I & IIWO-2 Bridge Repair Plans 68H20-011-Structural Steel Repairs.dgn  
 1/22/2024 9:51:36 AM



USER NAME = z davidson	DESIGNED - ZLD	REVISED -
0290056-68H20-011-Structural Steel Repairs.dgn	CHECKED - RPW	REVISED -
PLOT SCALE = 45:10.0000 "/>		

**STATE OF ILLINOIS**  
**DEPARTMENT OF TRANSPORTATION**

**STRUCTURAL STEEL REPAIRS**  
**STRUCTURE NO. 029-0056**

SHEET 11 OF 15 SHEETS

F.A.P. RTE. 30	SECTION 139,138(BC,BC-1)BR,BR-1)BR	COUNTY FULTON	TOTAL SHEETS 119	SHEET NO. 102
CONTRACT NO. 68H20				
ILLINOIS FED. AID PROJECT				

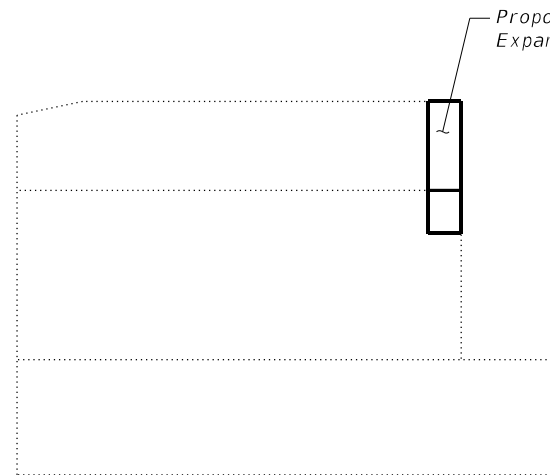

**NORTHWEST WINGWALL**  
(Looking East)

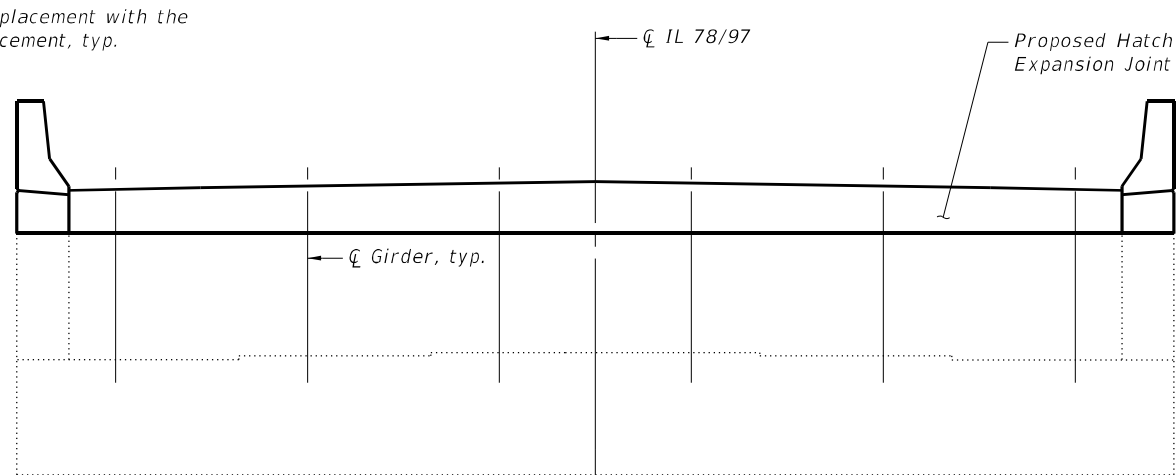

**NORTH ABUTMENT ELEVATION**  
(Looking North)

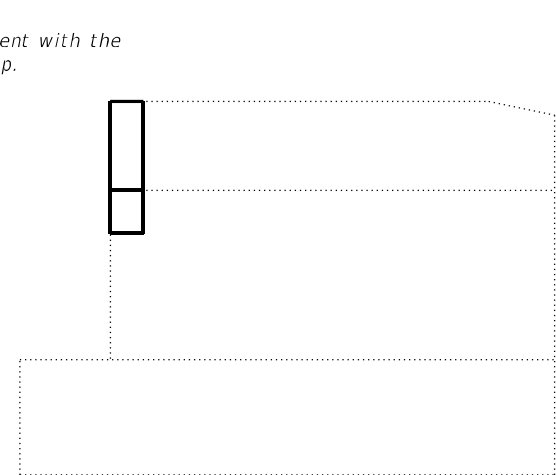

**NORTHEAST WINGWALL**  
(Looking West)

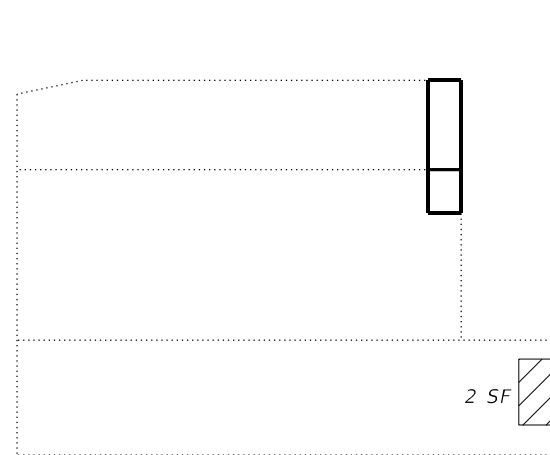

**SOUTHEAST WINGWALL**  
(Looking West)

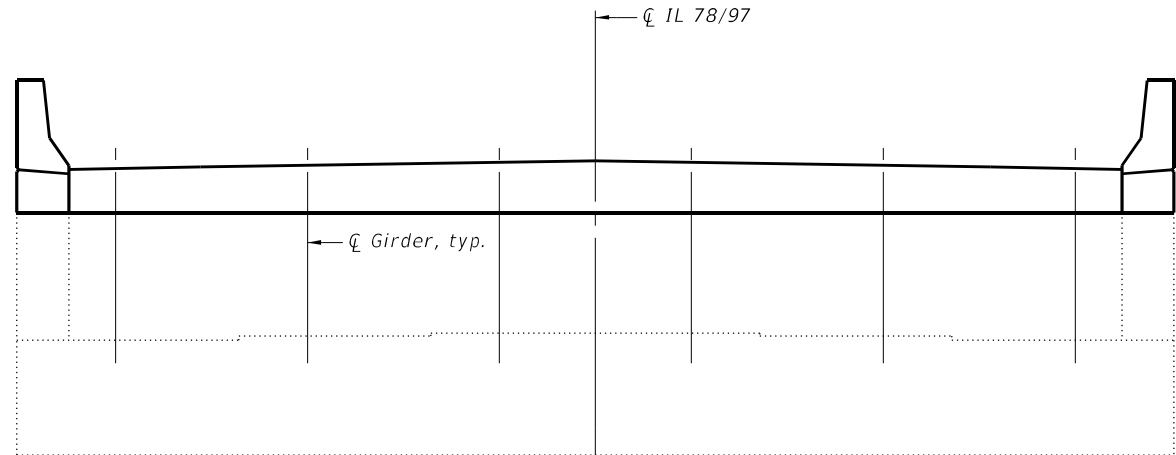

**SOUTH ABUTMENT ELEVATION**  
(Looking South)

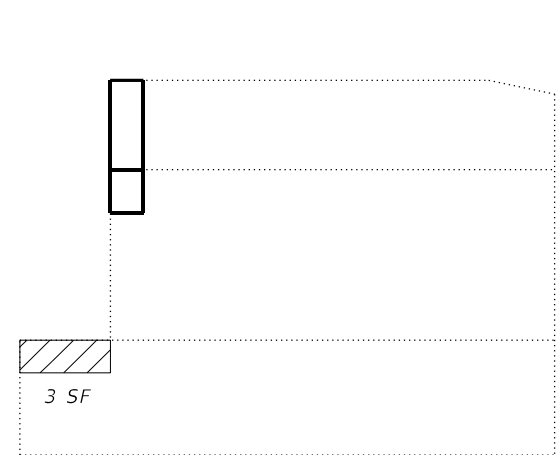

**SOUTHWEST WINGWALL**  
(Looking East)

Note:  
For wingwall and hatch block details with the expansion joint replacement, see sheets 8 and 9 of 15.

**LEGEND**

 Structural Repair of Concrete (Depth Equal to or Less Than 5")

**BILL OF MATERIAL**

Item	Unit	Total
Structural Repair of Concrete (Depth Equal to or Less Than 5 Inches)	Sq. Ft.	5

MODEL: \$MODELNAME\$  
FILE NAME: \$FILES



USER NAME = \$USER\$	DESIGNED - ZLD	REVISED -
\$FILE\$	CHECKED - RPW	REVISED -
PLOT SCALE = \$SCALE\$	DRAWN - JDC	REVISED -
PLOT DATE =	CHECKED - MDC	REVISED -

**STATE OF ILLINOIS  
DEPARTMENT OF TRANSPORTATION**

**ABUTMENT REPAIRS  
STRUCTURE NO. 029-0056**

SHEET 12 OF 15 SHEETS

F.A.P. RTE.	SECTION	COUNTY	TOTAL SHEETS	SHEET NO.
30	[139,138(BC;BC-1)BR,BR-1]BRR	FULTON	119	103
CONTRACT NO. 68H20				
ILLINOIS FED. AID PROJECT				

SDATE\$ \$TIME\$

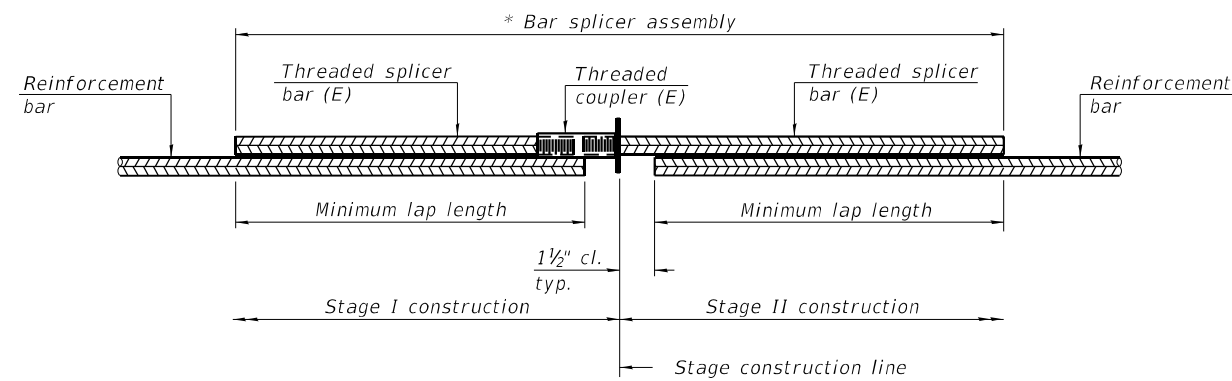

**STANDARD BAR SPLICER ASSEMBLY PLAN**

Only bar splicer assemblies as presented on the approved QPL list may be used.

Threaded splicer bar length = min. lap length + 1 1/2" + thread length

\* Epoxy not required on Bar Splicer Assembly components used in conjunction with black bars.

Location	Bar size	No. assemblies required	Minimum lap length
Bridge Deck Side of Exp. Jt.	#5	18	3'-4"
Appr. Side of Exp. Jt.	#6	8	4'-0"

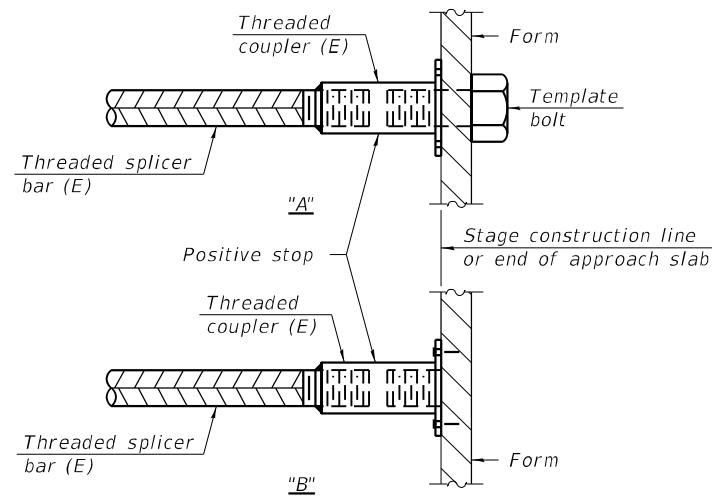

**INSTALLATION AND SETTING METHODS**

"A" : Set bar splicer assembly by means of a template bolt.

"B" : Set bar splicer assembly by nailing to wood forms or cementing to steel forms.

(E) : Indicates epoxy coating.

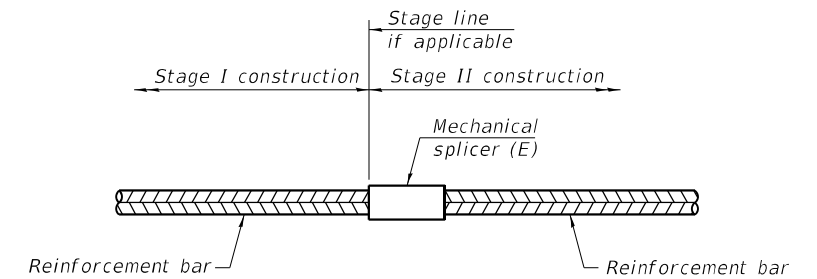

**STANDARD MECHANICAL SPLICER**

Location	Bar size	No. assemblies required

**Notes:**

Splicer bars shall be deformed with threaded ends and have a minimum 60 ksi yield strength.

All reinforcement shall be lapped and tied to the splicer bars.

Bar splicer assemblies shall be epoxy coated according to the requirements for reinforcement bars. See Section 508 of the Standard Specifications.

See approved list of bar splicer assemblies and mechanical splicers for alternatives.

MODEL: \$MODELNAME\$  
FILE NAME: \$FILES\$

BSD-1

2-1-2023



USER NAME = \$USERS\$	DESIGNED - ZLD	REVISED -
\$FILES\$	CHECKED - RPW	REVISED -
PLOT SCALE = \$SCALE\$	DRAWN - JDC	REVISED -
PLOT DATE =	CHECKED - MDC	REVISED -

STATE OF ILLINOIS  
DEPARTMENT OF TRANSPORTATION

BAR SPLICER ASSEMBLY AND MECHANICAL SPLICER DETAILS  
STRUCTURE NO. 029-0056

SHEET 13 OF 15 SHEETS

F.A.P. RTE.	SECTION	COUNTY	TOTAL SHEETS	SHEET NO.
30	[139,138(BC;BC-1)BR,BR-1]BRR	FULTON	119	104
CONTRACT NO. 68H20				

ILLINOIS FED. AID PROJECT



ROUTE NO.	SECTION	COUNTY	TOTAL SHEETS	SHEET NO.
F.A.P. 30	(138 BC) BR	FULTON	86	46A
FED. ROAD DIST. NO. 7 ILLINOIS FED. AID PROJECT				

SHEET NO 9  
27 SHEETS

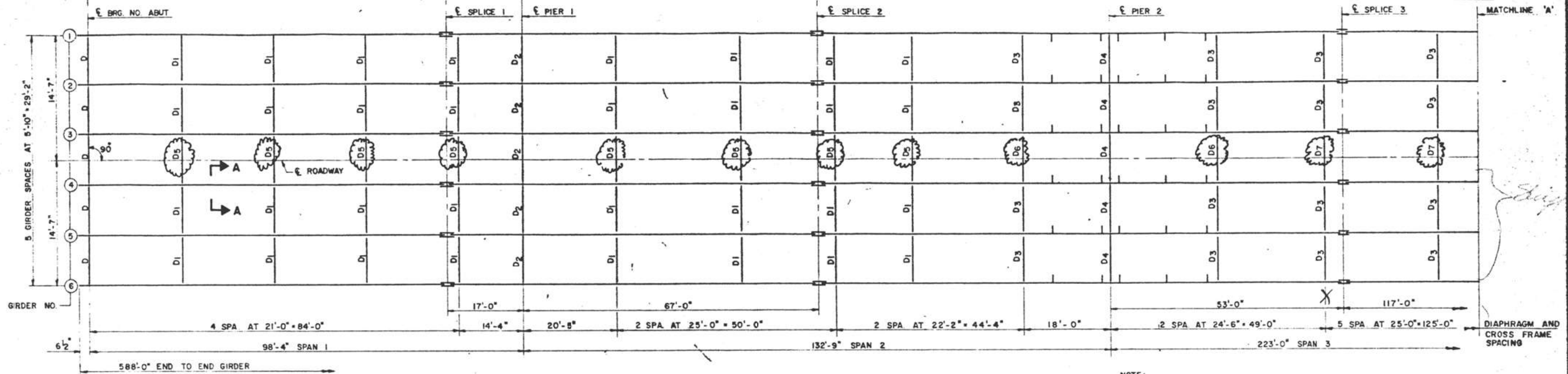

FRAMING PLAN

NOTES: DIAPHRAGMS AND CROSS FRAMES BETWEEN GIRDER (3) & (4) TO BE PLACED DURING STAGE II CONSTRUCTION.

NOTE:  
FOR SECTION A-A & GIRDER ELEVATION, SEE SHEET # 10 OF 27.  
FOR MISCELLANEOUS FRAMING DETAILS, SEE SHEET # 11 OF 27.  
FOR FIELD SPLICE DETAILS, SEE SHEET # 12 OF 27.  
FOR FRAMING DETAILS, SEE SHEET # 13 OF 27.

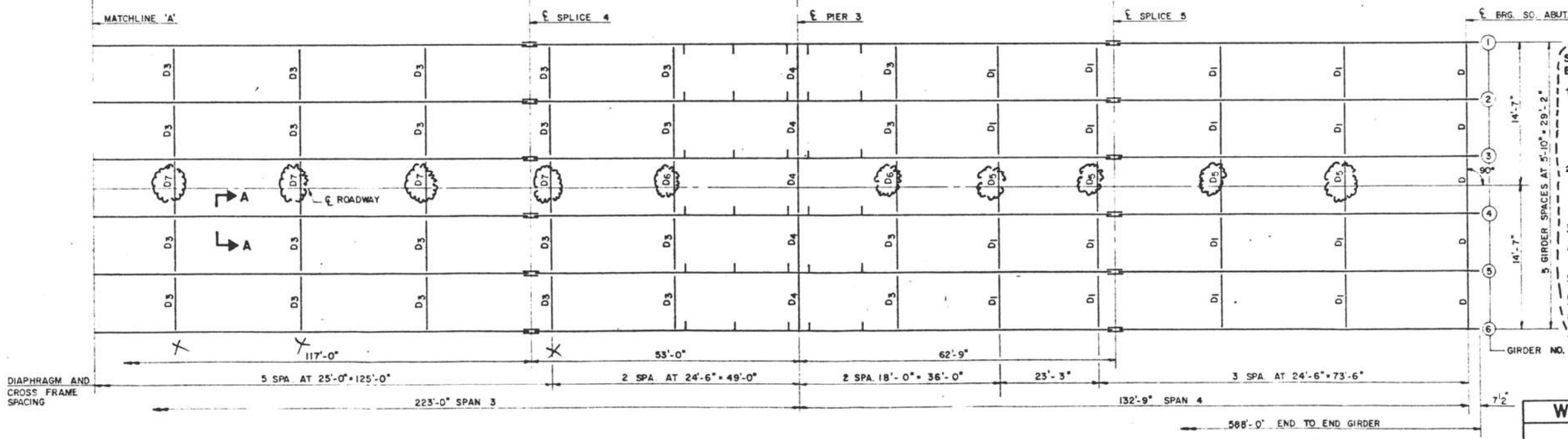

FRAMING PLAN

- STAGE II SUPERSTRUCTURE ERECTION SEQUENCE**
- 1) ERECT GIRDERS 1, 2 AND 3 BETWEEN NORTH ABUTMENT AND SPLICE 3 AND BETWEEN SPLICE 4 AND SOUTH ABUTMENT. INSTALL ALL DIAPHRAGMS AND CROSS FRAMES EXCEPT D7. THE CONNECTION BOLTS FOR THE DIAPHRAGMS AND CROSS FRAMES BETWEEN GIRDERS 3 AND 4 ARE TO BE HAND TIGHTENED ONLY.
  - 2) ERECT GIRDERS 1, 2 AND 3 BETWEEN SPLICE 3 AND SPLICE 4. INSTALL CROSS FRAMES D5. ALSO INSTALL CROSS FRAMES D7 TO GIRDER 4 ONLY. CONNECTION BOLTS FOR CROSS FRAME D7 ARE TO BE HAND TIGHTENED ONLY.
  - 3) POUR CONCRETE IN AREA III AND IV. SEE DECK CONCRETE POUR SCHEDULE ON SHEET 7.
  - 4) FIELD DRILL HOLES IN WEST CONNECTION PLATE OF GIRDER 3 TO MATCH HOLES IN GUSSET PLATE OF CROSS FRAME D7.
  - 5) INSTALL BOLTS BETWEEN GIRDER 3 AND CROSS FRAME D7. HAND TIGHTENING ONLY.
  - 6) TIE THE LAPPED BARS IN AREA V.
  - 7) POUR CONCRETE IN AREA V.
  - 8) TIGHTEN THE DIAPHRAGM AND CROSS FRAME CONNECTION BOLTS BETWEEN GIRDERS 3 AND 4 AS SPECIFIED IN THE GENERAL NOTES.

**WELLS ENGINEERS, INC.**  
FRAMING PLAN  
1L ROUTES 78 & 97  
OVER SPOON RIVER  
F.A.P. ROUTE 30 SEC (138 BC) BR  
STA. 508+11.38  
FULTON COUNTY  
STRUCTURE NO. 029-0056  
DATE: 12-3-87 DRAWN BY: GLH JOB NO 860672  
DESIGNED BY: KRP CHECKED BY: SDK SHEET NO. 9 OF 27

**FOR INFORMATION ONLY**

AS REVISED

Revised 3-16-89, M.H.B.

MODEL: SMODELNAMES  
FILE NAME: SFILES

**QEI**  
QUIGG ENGINEERING INC  
SDATES\$ STIMES\$

USER NAME =	SUSERS	DESIGNED -	ZLD	REVISED -	
\$FILESS		CHECKED -	RPW	REVISED -	
PLOT SCALE =	\$\$SCALE\$	DRAWN -	JDC	REVISED -	
PLOT DATE =		CHECKED -	MDC	REVISED -	

STATE OF ILLINOIS  
DEPARTMENT OF TRANSPORTATION

EXISTING PLANS REFERENCE SHEET  
STRUCTURE NO. 029-0056

SHEET 14 OF 15 SHEETS

F.A.P. RTE.	SECTION	COUNTY	TOTAL SHEETS	SHEET NO.
30	(139,138/BC/BC-1)BR, BR-1BRR	FULTON	119	105
CONTRACT NO. 68H20				
ILLINOIS FED. AID PROJECT				

ROUTE NO. F.A.P. 30	SECTION (138 BC) BR	COUNTY FULTON	TOTAL SHEETS 86	SHEET NO. 47	SHEET NO. 10 OF 27 SHEETS
FED. ROAD DIST. NO. 7   ILLINOIS   FED. AID PROJECT					

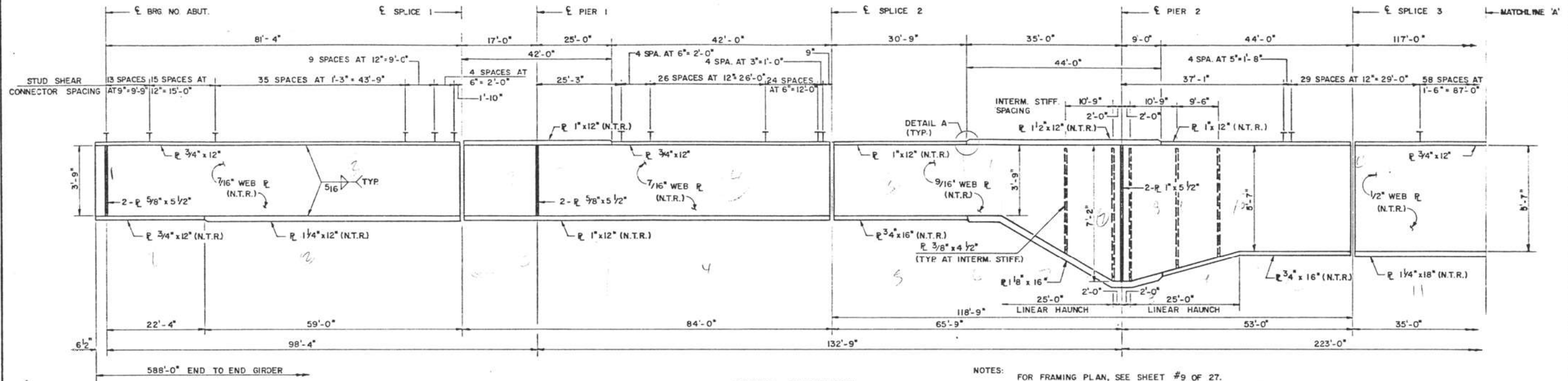

**GIRDER ELEVATION**

N.T.R. = NOTCH TOUGHNESS REQUIREMENTS.

(ALL GIRDER STEEL IS AASHTO M223, GR. 50 & ALL INTERM. STIFF. STEEL IS AASHTO M183.)

- NOTES:
- FOR FRAMING PLAN, SEE SHEET #9 OF 27.
  - FOR MISCELLANEOUS FRAMING DETAILS, SEE SHEET #11 OF 27.
  - FOR FIELD SPLICE DETAILS, SEE SHEET #12 OF 27.
  - FOR FRAMING DETAILS, SEE SHEET #13 OF 27.

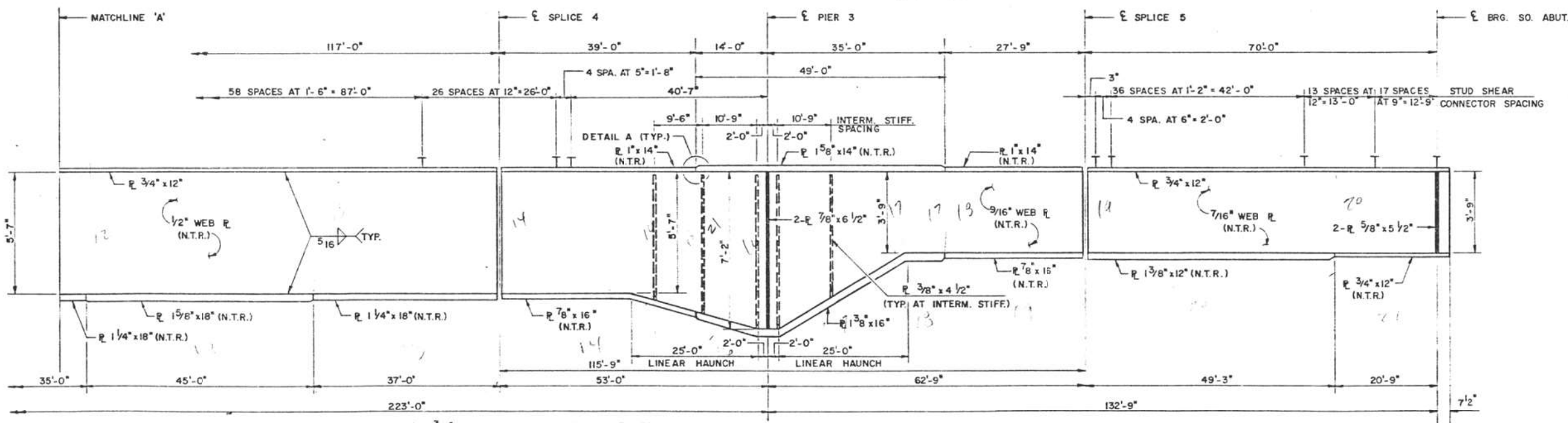

**GIRDER ELEVATION**

NOTE:  
ALL STRUCTURAL STEEL FABRICATORS PERFORMING WORK ON THE MAIN LOAD CARRYING COMPONENTS OF STEEL STRUCTURES SHALL BE CERTIFIED UNDER CATEGORY III (AISC) OF THE QUALITY CERTIFICATION PROGRAM.

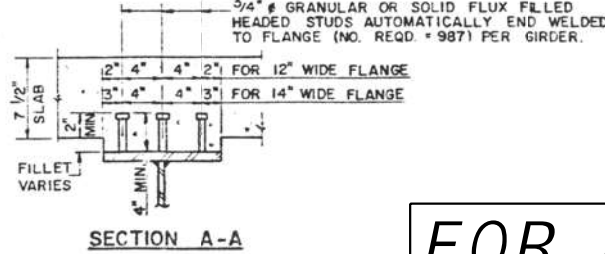
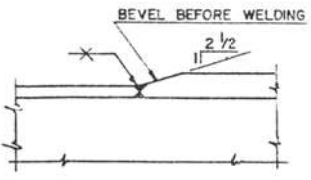

**FOR INFORMATION ONLY**

**WELLS ENGINEERS, INC.**  
 GIRDER ELEVATION  
 IL ROUTES 78 & 97  
 OVER SPOON RIVER  
 F.A.P. ROUTE 30 SEC (138 BC) BR  
 STA. 508+11.38  
 FULTON COUNTY  
 STRUCTURE NO. 029-0056  
 DATE: 12-3-87 DRAWN BY: GLH JOB NO. 860672  
 DESIGNED BY: KRP CHECKED BY: SDK SHEET NO. 10 OF 27

MODEL: SMODELNAMES  
FILE NAME: SFILES

**QEI**  
 QUIGG ENGINEERING INC  
 SDATES \$TIMES\$

USER NAME = \$USERS\$	DESIGNED - ZLD	REVISED -
\$FILES\$	CHECKED - RPW	REVISED -
PLOT SCALE = \$\$SCALE\$	DRAWN - JDC	REVISED -
PLOT DATE =	CHECKED - MDC	REVISED -

STATE OF ILLINOIS  
 DEPARTMENT OF TRANSPORTATION

EXISTING PLANS REFERENCE SHEET  
 STRUCTURE NO. 029-0056  
 SHEET 15 OF 15 SHEETS

F.A.P. RTE. 30	SECTION (139,138)(BC,BC-1)BR, BR-1BRR	COUNTY FULTON	TOTAL SHEETS 119	SHEET NO. 106
CONTRACT NO. 68H20				
ILLINOIS FED. AID PROJECT				

Existing Structure: SN 029-0021, originally built in 1936 as a Three-Span continuous wide flange steel beam superstructure with open abutments and multi-column piers. In 1989, the structure was reconstructed by modifying the substructure units & replacing the superstructure. The back to back length = 168'-6<sup>3</sup>/<sub>8</sub>" and the out to out = 35'-2". Structure is to be repaired as detailed in these plans. Traffic is to be maintained using stage construction.

No Salvage.

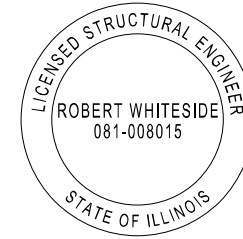

*Robert Whiteside*

Robert Whiteside, Illinois S.E. 081-008015  
Expires 11/30/2024

12/14/2023  
Date

**INDEX OF SHEETS**

1. General Plan and Elevation
2. General Data
3. Stage Construction Details
4. Temporary Concrete Barrier
5. Deck Overlay Plan
6. Parapet Repairs
- 7-8. Expansion Joint Details
9. Preformed Joint Strip Seal
10. Beam End Repairs
11. Abutment Repairs
12. Bar Splicer Assembly and Mechanical Splicer Details
13. Existing Plans Reference Sheet

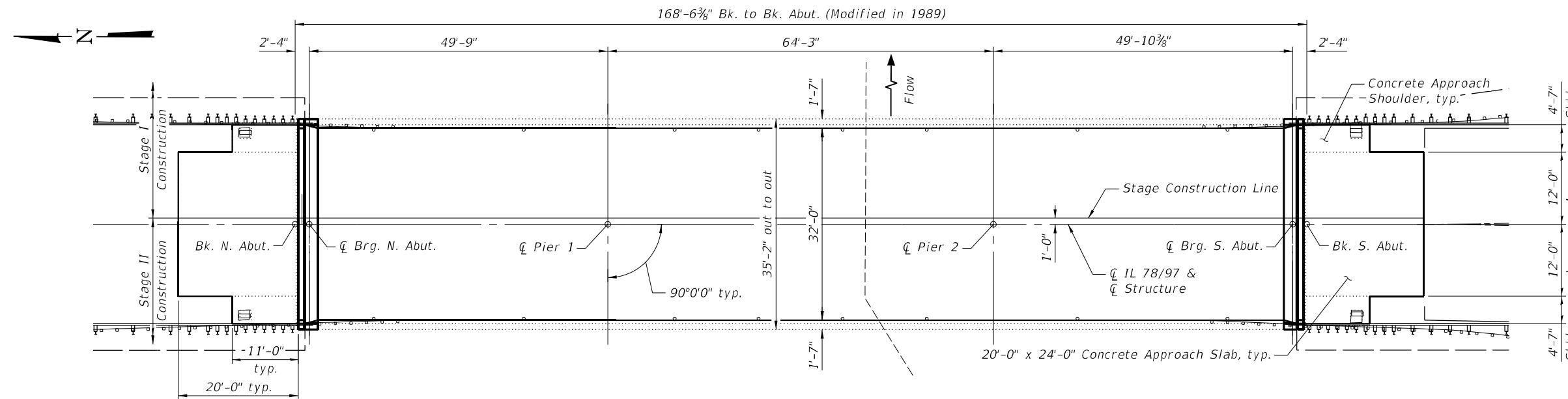
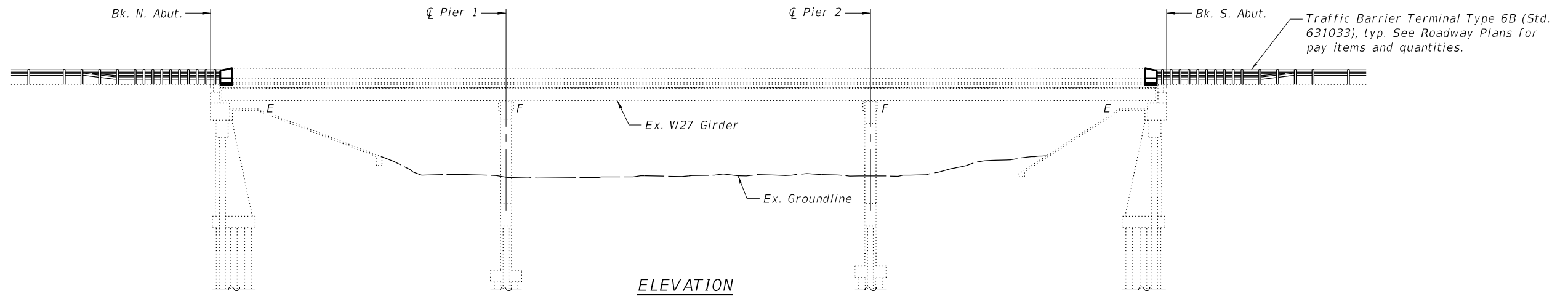

**DESIGN STRESSES**

**FIELD UNITS (EXIST. CONST.)**

- $f'_c = 3,500$  psi
- $f_y = 60,000$  psi (Reinforcement)
- $f_y = 50,000$  psi (Structural Steel M223 Grade 50)
- $f_y = 36,000$  psi (Structural Steel M183 Grade 36)

**FIELD UNITS (NEW CONST.)**

- $f'_c = 4,000$  psi
- $f_y = 60,000$  psi (Reinforcement)
- $f_y = 36,000$  psi (M270 Grade 36)
- $f_y = 50,000$  psi (M270 Grade 50)

**LOADING HS-20**  
Existing and Proposed

**DESIGN SPECIFICATIONS**  
2002 AASHTO Standard Specifications  
for Highway Bridges - LFD

**PLAN**

**SCOPE OF WORK**

1. Replace the transverse expansion joints.
2. Scarify the bridge deck and approach pavements.
3. Complete full depth slab repairs.
4. Place a microsilica concrete overlay.
5. Concrete repair of parapets.
6. Steel beam end repairs.
7. Concrete repair of abutments.
8. Fill void beneath North and South Slopewall with CLSM.

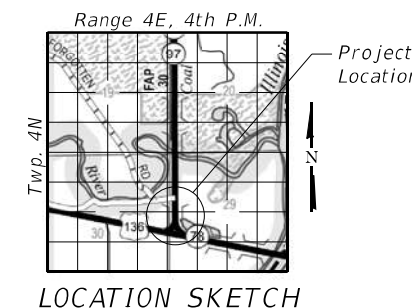

**GENERAL PLAN AND ELEVATION**  
**IL 78/97 OVER LACY DITCH**  
**FAP ROUTE 30**  
**SECTION [139,138(BC;BC-1)BR,BR-1]BRR**  
**FULTON COUNTY**  
**STRUCTURE NO. 029-0021**

MODEL: \$MODELNAME\$  
FILE NAME: \$FILES\$



USER NAME = \$USERS\$	DESIGNED - CFS	REVISED -
\$FILES\$	CHECKED - RPW	REVISED -
PLOT SCALE = \$SCALE\$	DRAWN - JDC	REVISED -
PLOT DATE =	CHECKED - MDC	REVISED -

**STATE OF ILLINOIS**  
**DEPARTMENT OF TRANSPORTATION**

**GENERAL PLAN AND ELEVATION**  
**STRUCTURE NO. 029-0021**

SHEET 1 OF 13 SHEETS

F.A.P. RTE.	SECTION	COUNTY	TOTAL SHEETS	SHEET NO.
30	[139,138(BC;BC-1)BR,BR-1]BRR	FULTON	119	107
CONTRACT NO. 68H20				
ILLINOIS FED. AID PROJECT				

SDATE\$ \$TIMES\$

**GENERAL NOTES**

Fasteners shall be ASTM A325 Type 1, mechanically galvanized bolts. Bolts 3/4" Ø, holes 15/16" Ø, unless otherwise noted.

Calculated weight of Structural Steel = 60 lbs (M270 Grade 50).

All structural steel shall be AASHTO M270 Grade 50, unless otherwise noted.

No field welding is permitted except as specified in the contract documents.

Reinforcement bars designated (E) shall be epoxy coated.

Plan dimensions and details relative to existing plans are subject to nominal construction variations. The Contractor shall field verify existing dimensions and details affecting new construction and make necessary approved adjustments prior to construction or ordering of materials. Such variations shall not be cause for additional compensation for a change in scope of the work, however, the Contractor will be paid for the quantity actually furnished at the unit price bid for the work.

Any reinforcement bars that are to remain that are damaged during concrete removal operations shall be repaired or replaced using an approved bar splicer or anchorage system. Cost included with Concrete Removal.

Existing longitudinal and vertical reinforcement bars remaining and extending into the removal areas shall be cleaned, straightened and incorporated into the new construction. Cost included with Concrete Removal.

Prior to pouring the new concrete deck, all heavy or loose rust, loose mill scale, and other loose or potentially detrimental foreign material shall be removed from the surfaces in contact with concrete. Tightly adhered paint may remain unless otherwise noted. Removal shall be accomplished by methods that will not damage the steel and the cost will be included in the pay item covering removal of the existing concrete.

The protective coat shall be applied to the new microsilica concrete overlay, new bridge deck concrete, and top and inside faces of the new portions of the parapets and wingwalls.

Joint openings shall be adjusted according to Article 520.04 of the Standard Specifications when the deck is poured at an ambient temperature other than 50°F.

All repairs including structural steel angles, bolts, nuts and washers shall be galvanized per the special provision "Hot Dip Galvanizing for Structural Steel". Cost included in Structural Steel Repair.

The voids beneath the South Slopewall shall be filled with Controlled Low-Strength Material (CLSM) per the direction of the Engineer.

**Notes:**

All structural steel shall conform to AASHTO M270 Grade 36. The adjusting scupper ring shall be galvanized.

The contractor shall ensure that no damage is done to the existing grates that are to be reused.

Shop plans for the proposed adjusting inlet ring shall be submitted for approval prior to fabrication.

Cost of all labor and materials necessary to remove existing grates, clean existing inlets, install adjusting inlet rings and reinstall grates is included in the cost per unit each for Inlets to be Adjusted.

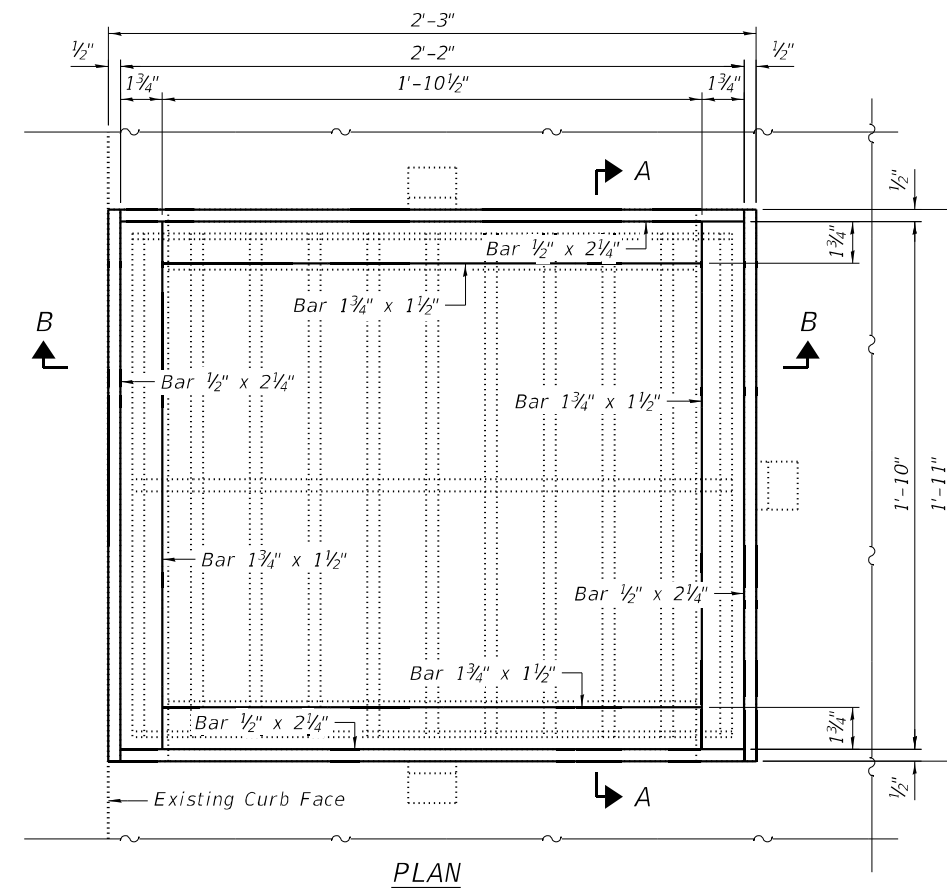
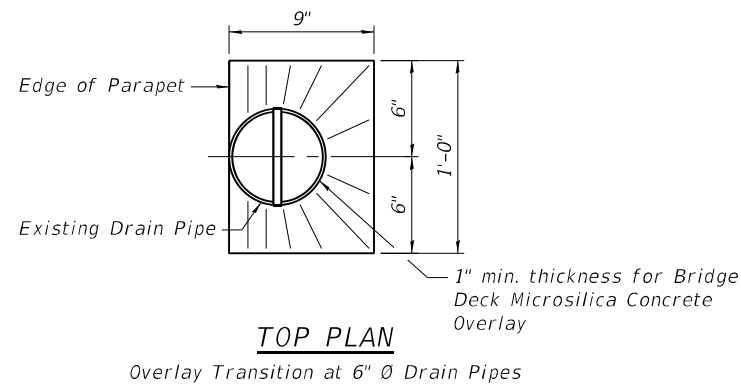

**TOTAL BILL OF MATERIAL**

Item	Unit	Super	Sub	Total
Concrete Removal	Cu. Yd.	9.5	-	9.5
Concrete Superstructure	Cu. Yd.	10.4	-	10.4
Bridge Deck Grooving	Sq. Yd.	681	-	681
Protective Coat	Sq. Yd.	729	-	729
Reinforcement Bars, Epoxy Coated	Pound	1,660	-	1,660
Bar Splicers	Each	26	-	26
Preformed Joint Strip Seal	Foot	66	-	66
Controlled Low-Strength Material	Cu. Yd.	-	10	10
Inlets to be Adjusted	Each	4	-	4
Structural Steel Repair	Pound	60	-	60
Bridge Deck Scarification 3/4"	Sq. Yd.	702	-	702
Bridge Deck Microsilica Concrete Overlay 2 1/4"	Sq. Yd.	702	-	702
Structural Repair of Concrete (Depth Equal to or Less than 5 inches)	Sq. Ft.	2	4	6
Deck Slab Repair (Full Depth, Type II)	Sq. Yd.	2	-	2
Slope Wall Slurry Pumping	Cu. Yd.	-	10	10

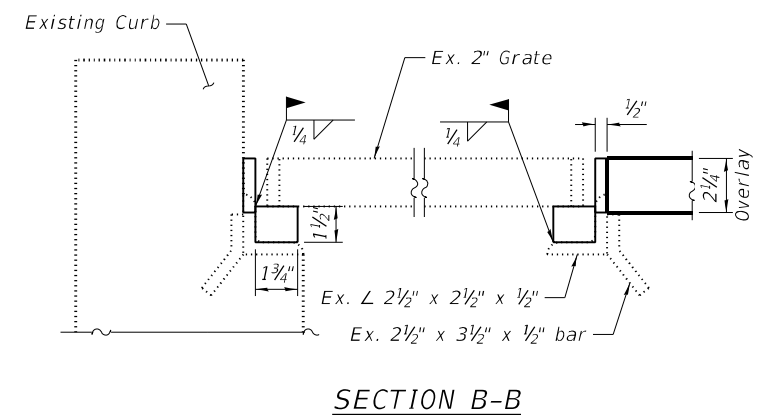
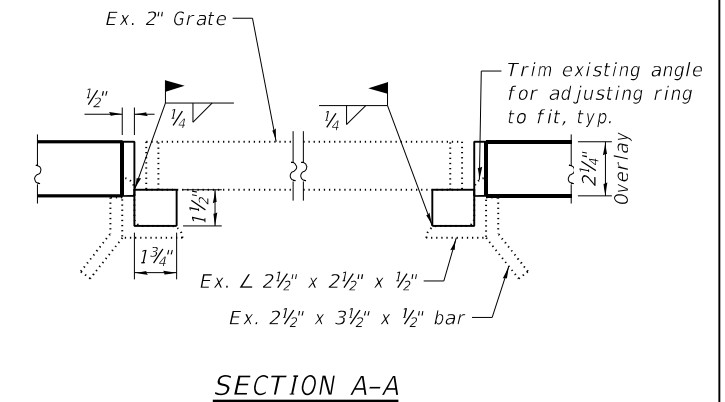

**SHOULDER INLET ADJUSTING RING DETAILS**

MODEL: SMODELNAMES  
FILE NAME: \$FILES



QUIGG ENGINEERING INC

USER NAME = \$USERS\$	DESIGNED - CFS	REVISED -
\$FILES\$	CHECKED - RPW	REVISED -
PLOT SCALE = \$SCALE\$	DRAWN - JDC	REVISED -
PLOT DATE =	CHECKED - MDC	REVISED -

STATE OF ILLINOIS  
DEPARTMENT OF TRANSPORTATION

GENERAL DATA  
STRUCTURE NO. 029-0021

SHEET 2 OF 13 SHEETS

F.A.P. RTE.	SECTION	COUNTY	TOTAL SHEETS	SHEET NO.
30	(139,138/BC/BC-1)BR, BR-1)BRR	FULTON	119	108
CONTRACT NO. 68H20				
ILLINOIS FED. AID PROJECT				

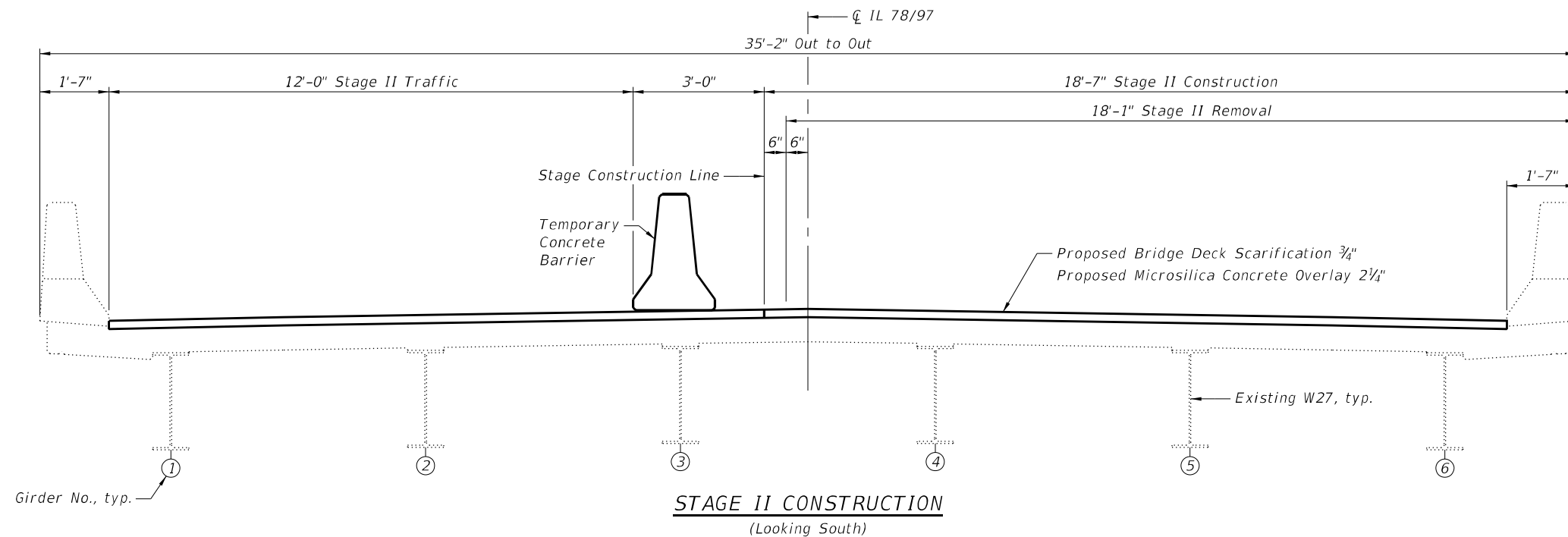
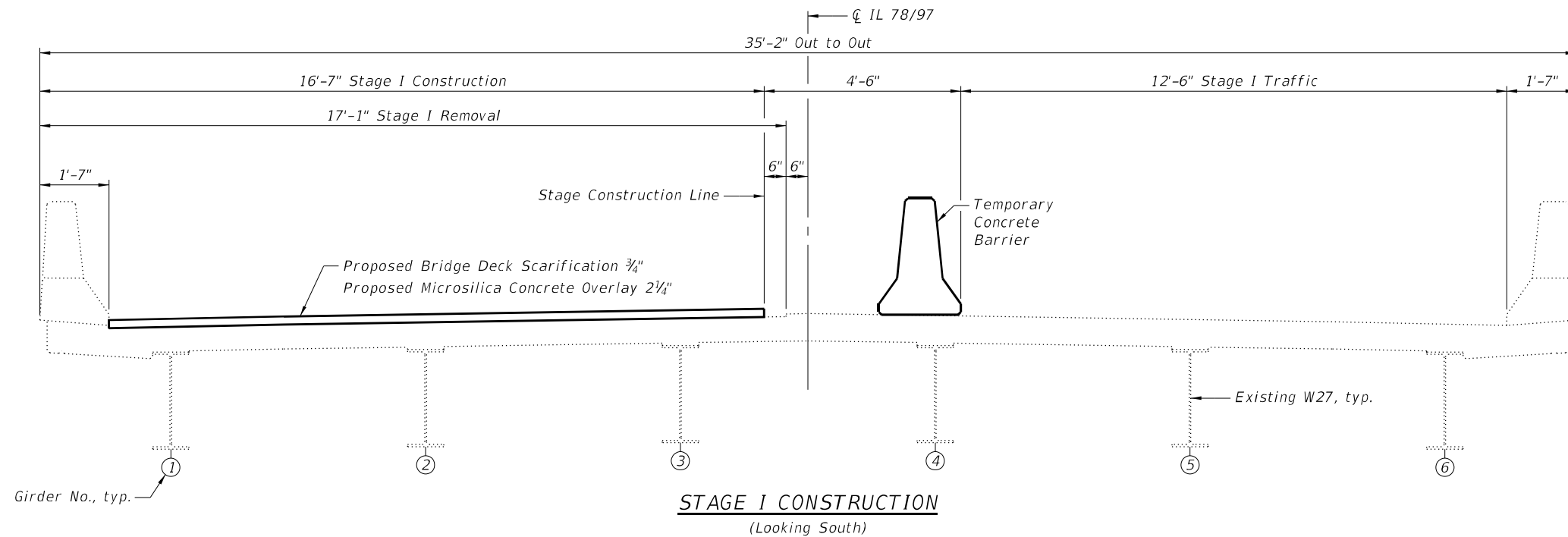

MODEL: \$MODELNAME\$  
FILE NAME: \$FILES



QUIGG ENGINEERING INC

USER NAME = \$USER\$	DESIGNED - CFS	REVISED -
\$FILES\$	CHECKED - RPW	REVISED -
PLOT SCALE = \$SCALE\$	DRAWN - JDC	REVISED -
PLOT DATE =	CHECKED - MDC	REVISED -

**STATE OF ILLINOIS  
DEPARTMENT OF TRANSPORTATION**

**STAGE CONSTRUCTION DETAILS  
STRUCTURE NO. 029-0021**

SHEET 3 OF 13 SHEETS

F.A.P. RTE.	SECTION	COUNTY	TOTAL SHEETS	SHEET NO.
30	[139,138(BC;BC-1)BR,BR-1]BRR	FULTON	119	109
			CONTRACT NO. 68H20	
		ILLINOIS	FED. AID PROJECT	

SDATE\$ \$TIME\$

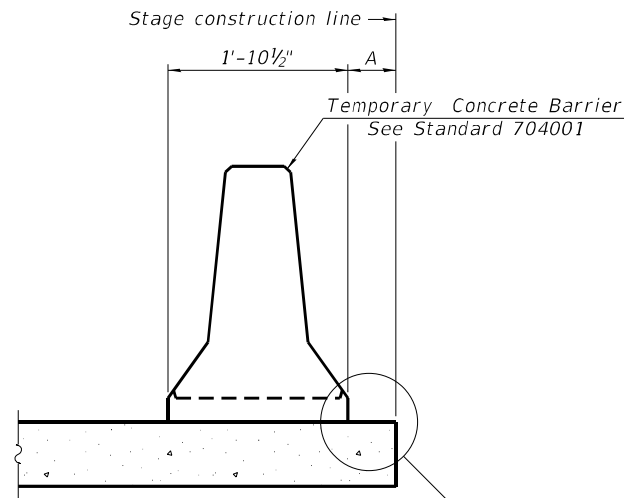

When "A" is 3'-1" or less, the temporary concrete barrier shall be restrained to the new slab according to Detail I, II or III. No restraint is required when "A" is greater than 3'-1".

NEW SLAB OR NEW DECK BEAM

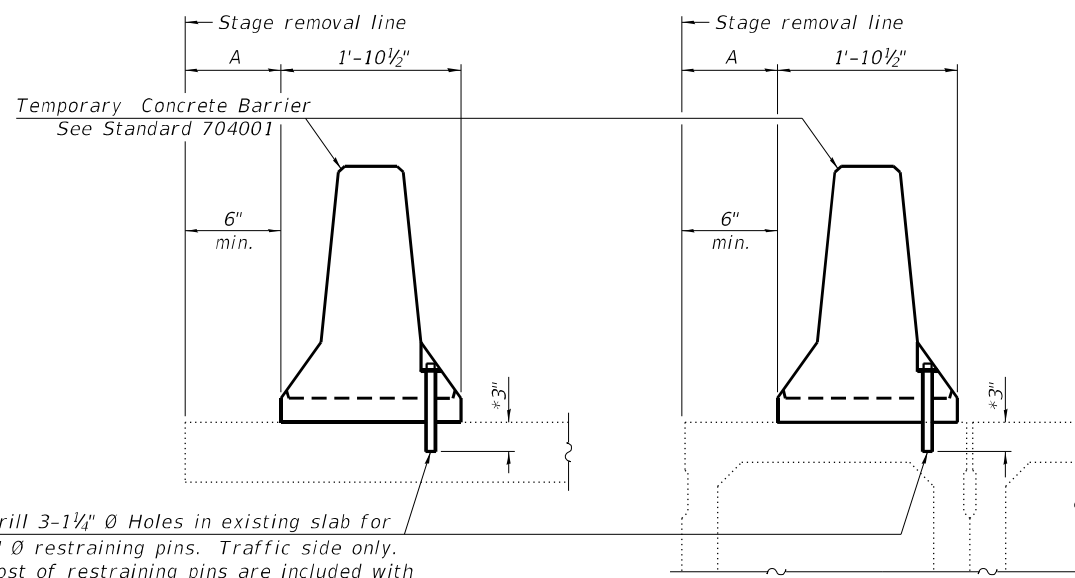

Drill 3-1/4" Ø Holes in existing slab for 1" Ø restraining pins. Traffic side only. Cost of restraining pins are included with Temporary Concrete Barrier. No restraint is required when "A" is greater than 3'-1".

EXISTING SLAB

\* When hot-mix asphalt wearing surface is present, embedment shall be 3" plus the wearing surface depth.

EXISTING DECK BEAM

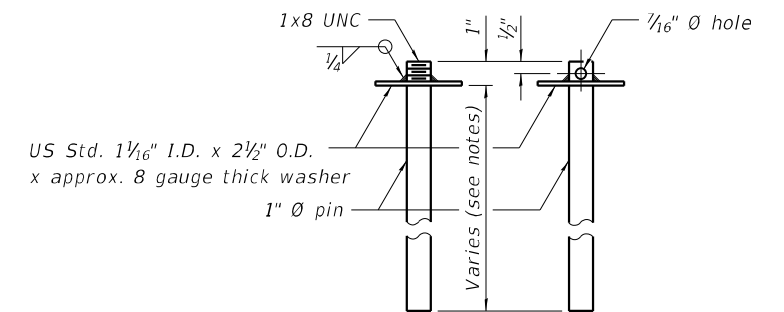

RESTRAINING PIN

SECTIONS THRU SLAB OR DECK BEAM

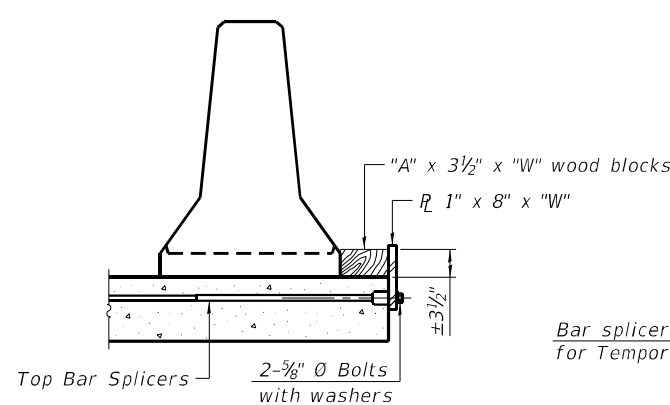

DETAIL I

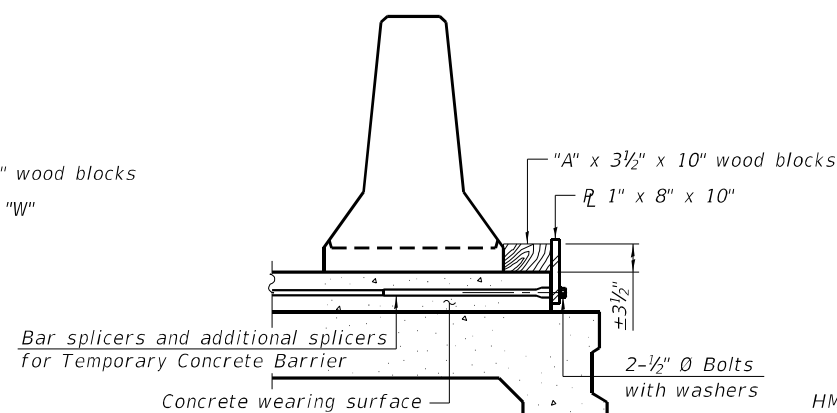

DETAIL II

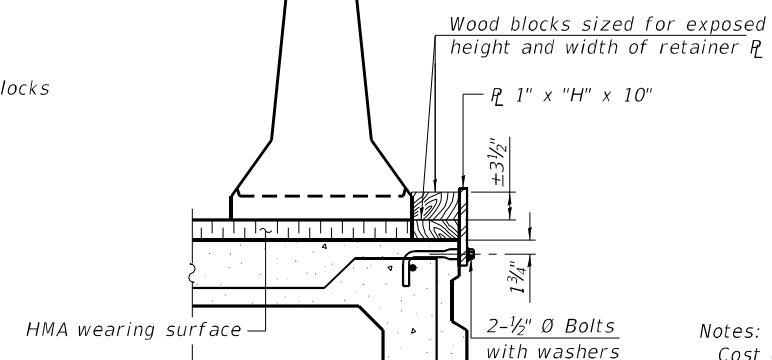

DETAIL III

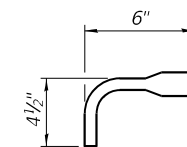

BAR SPLICER FOR #4 BAR - DETAIL III

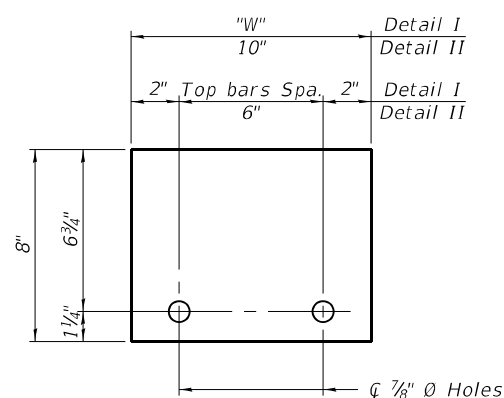

STEEL RETAINER R 1" x 8" x "W"  
(Detail I and II)

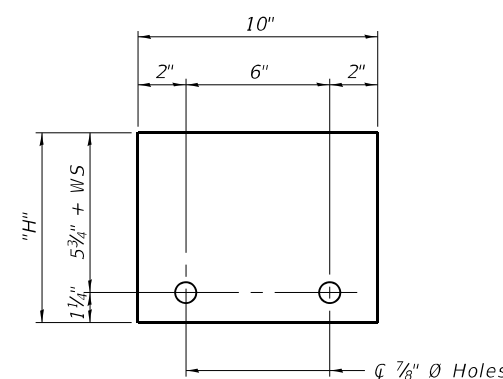

STEEL RETAINER R 1" x "H" x 10"  
(Detail III)

Notes:  
 Cost of retainer assembly is included with Temporary Concrete Barrier.  
 A retainer assembly shall be located at the approximate  $\bar{c}$  of each temporary concrete barrier.  
 The retainer plate shall not be removed until the concrete on the adjacent stage is ready to be poured. For Detail III applications the retainer plate shall not be removed until just prior to placing the adjacent beam.  
 When the 'A' dimension is less than 1 1/2', the wood block shall be omitted and the barrier shall be placed in direct contact with the steel retainer plate. For deck beam applications the minimum required 'A' distance is 6" to accommodate the shear key clamping device.

Detail I - Installation for a new bridge deck or bridge slab.  
 Detail II - Installation for a new deck beam with an initial concrete wearing surface. Additional bar splicers shall be provided at 6'-0" centers and paired with the bar splicers of the concrete wearing surface reinforcement to accommodate the installation of the retainer assemblies. The cost of the additional bar splicers is included with the concrete wearing surface.  
 Detail III - Installation for a new deck beam with no initial wearing surface or with an initial hot-mix asphalt (HMA) wearing surface present. The deck beam directly beneath the temporary concrete barrier shall be fabricated with bar splicer inserts in the side of the beam, as detailed, to accommodate the installation of the retainer assemblies. A pair of bar splicers, 6" apart, shall be placed at 6'-0" centers along the length of the beam. The cost of the bar splicers is included with the deck beam.

RAILING CRITERIA

NCHRP 350 Test Level	3
Railing Weight (plf)	440

R-27 10-12-2021

MODEL: \$MODELNAME\$  
FILE NAME: \$FILES\$



USER NAME = \$USERS\$	DESIGNED - CFS	REVISED -
\$FILESS\$	CHECKED - RPW	REVISED -
PLOT SCALE = \$SCALE\$	DRAWN - JDC	REVISED -
PLOT DATE =	CHECKED - MDC	REVISED -

STATE OF ILLINOIS  
DEPARTMENT OF TRANSPORTATION

TEMPORARY CONCRETE BARRIER  
STRUCTURE NO. 029-0021

SHEET 4 OF 13 SHEETS

F.A.P. RTE.	SECTION	COUNTY	TOTAL SHEETS	SHEET NO.
30	[139,138/BC/BC-1]BR, BR-1]BRR	FULTON	119	110
CONTRACT NO. 68H20				
ILLINOIS FED. AID PROJECT				

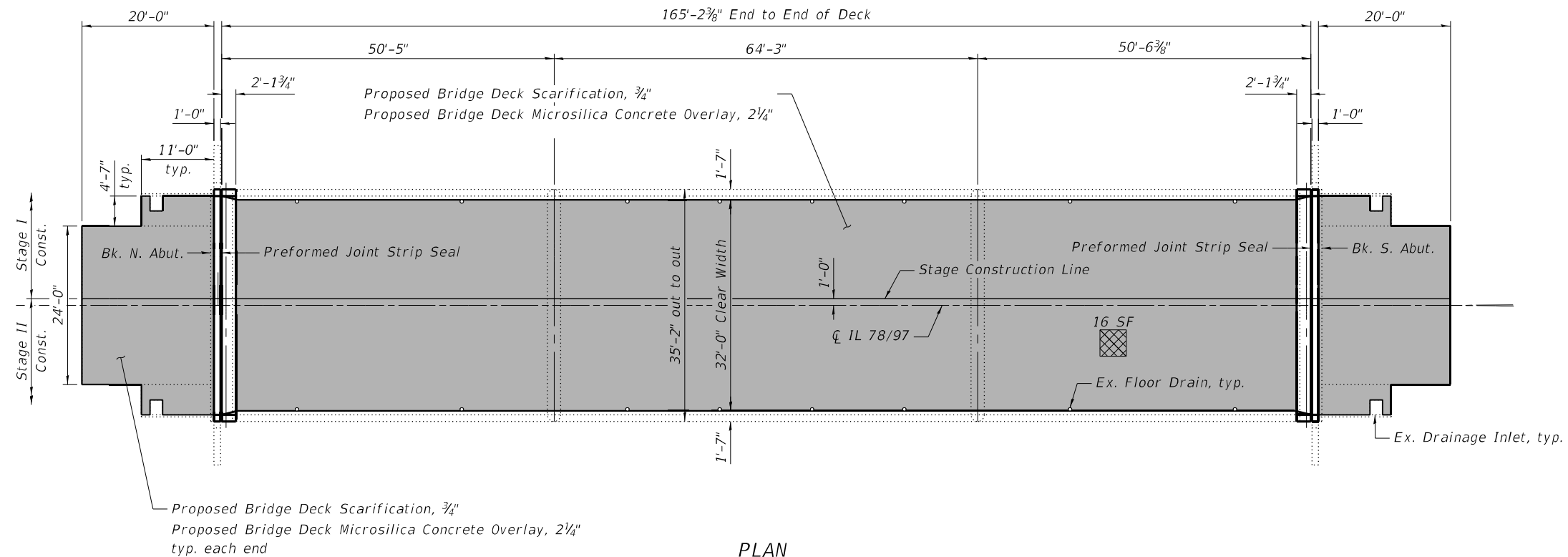
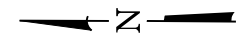

**PLAN**

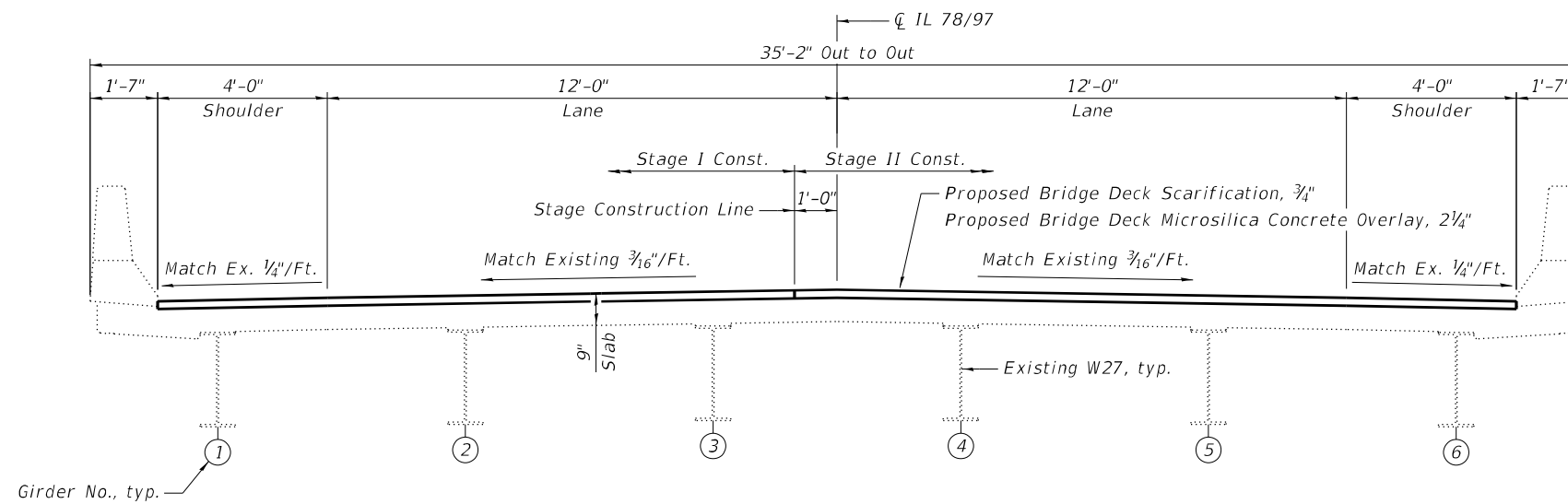

**CROSS SECTION**  
(Looking South)

**LEGEND**

- Deck Slab Repair (Full Depth, Type II)
- Scarification and Microsilica Concrete Overlay Limits

**Notes:**  
 See sheet 2 of 13 for overlay details at drainage scupper and drain pipes.  
 See sheets 7 thru 9 of 13 for expansion joint replacement details.  
 Deck Slab Repair (Full Depth, Type II) areas are estimated and will be field verified by the Engineer prior to patching. The Engineer shall show actual locations of deck repairs on as-built plans.

**TOTAL BILL OF MATERIAL**

ITEM	UNIT	TOTAL
Bridge Deck Grooving	Sq. Yd.	681
Protective Coat	Sq. Yd.	729
Bridge Deck Scarification 3/4"	Sq. Yd.	702
Bridge Deck Microsilica Concrete Overlay 2 1/4"	Sq. Yd.	702
Deck Slab Repair (Full Depth, Type II)	Sq. Yd.	2

MODEL: SMODELNAMES  
FILE NAME: SFILES



QUIGG ENGINEERING INC

USER NAME = \$USERS\$	DESIGNED - CFS	REVISED -
\$FILES\$	CHECKED - RPW	REVISED -
PLOT SCALE = \$SCALE\$	DRAWN - JDC	REVISED -
PLOT DATE =	CHECKED - MDC	REVISED -

**STATE OF ILLINOIS  
DEPARTMENT OF TRANSPORTATION**

**DECK OVERLAY PLAN  
STRUCTURE NO. 029-0021**

SHEET 5 OF 13 SHEETS

F.A.P. RTE.	SECTION	COUNTY	TOTAL SHEETS	SHEET NO.
30	[139,138(BC;BC-1)BR,BR-1]BRR	FULTON	119	111
CONTRACT NO. 68H20				
ILLINOIS FED. AID PROJECT				

SDATE\$ STIME\$

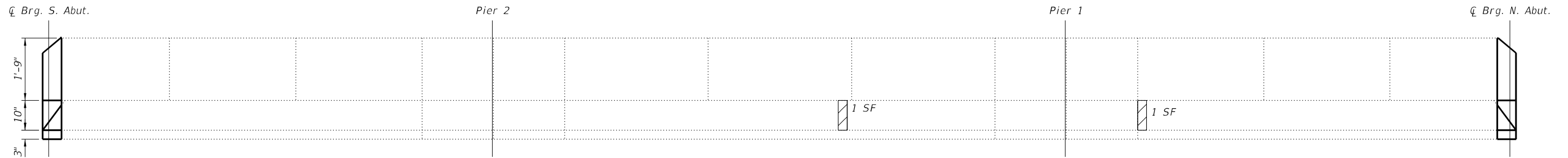

INSIDE FACE OF WEST PARAPET  
(Looking West)

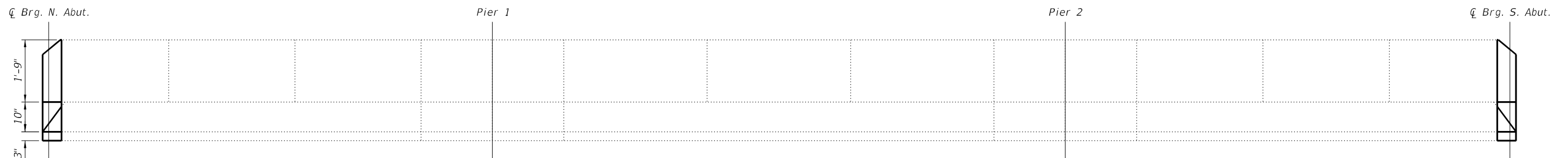

INSIDE FACE OF EAST PARAPET  
(Looking East)

**LEGEND**

Structural Repair of Concrete (Depth Equal to or less than 5")

Note:  
For expansion joint details, see sheets  
7 thru 9 of 13.

**BILL OF MATERIAL**

Item	Unit	Total
Structural Repair of Concrete (Depth Equal to or less than 5")	Sq. Ft.	2

MODEL: \$MODELNAME\$  
FILE NAME: \$FILES



QUIGG ENGINEERING INC

USER NAME = \$USER\$	DESIGNED - CFS	REVISED -
\$FILESS\$	CHECKED - RPW	REVISED -
PLOT SCALE = \$SCALE\$	DRAWN - JDC	REVISED -
PLOT DATE =	CHECKED - MDC	REVISED -

**STATE OF ILLINOIS  
DEPARTMENT OF TRANSPORTATION**

**PARAPET REPAIRS  
STRUCTURE NO. 029-0021**

SHEET 6 OF 13 SHEETS

F.A.P. RTE.	SECTION	COUNTY	TOTAL SHEETS	SHEET NO.
30	[139,138(BC;BC-1)BR,BR-1]BRR	FULTON	119	112
CONTRACT NO. 68H20				
ILLINOIS		FED. AID PROJECT		

SDATE\$ \$TIME\$



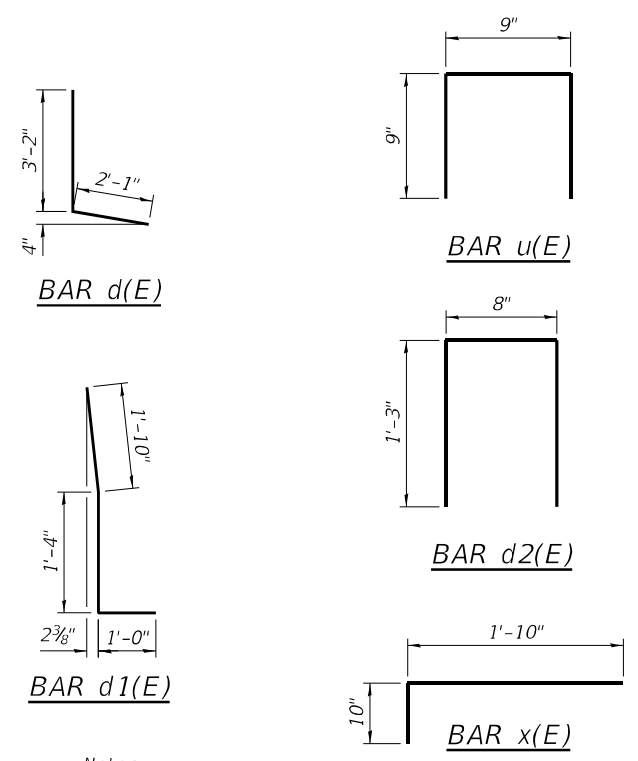
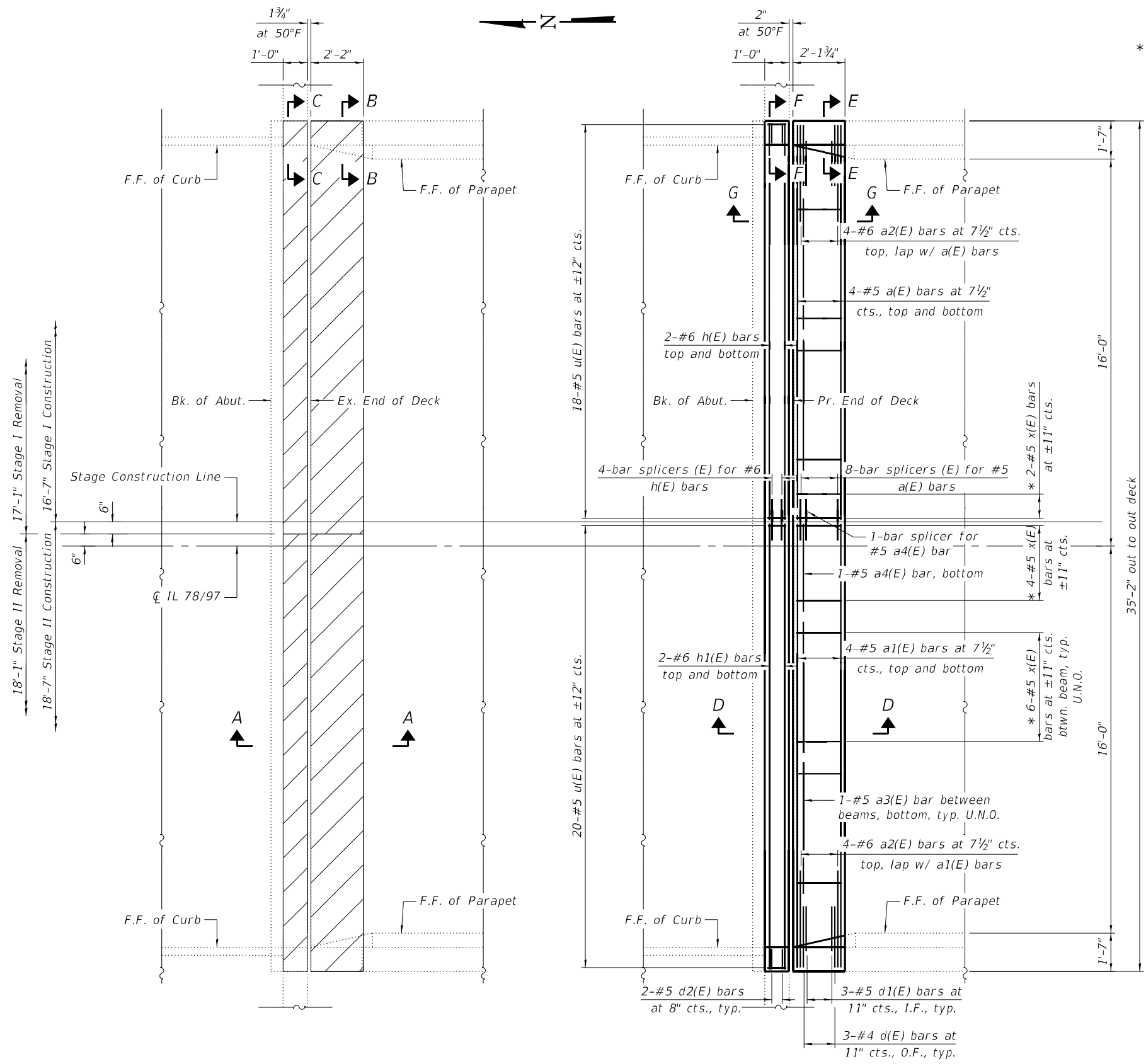

**Notes:**  
 Any reinforcement bars that are to remain that are damaged during concrete removal operations shall be repaired or replaced using an approved bar splicer or anchorage system. Cost included with Concrete Removal.  
 Existing longitudinal and vertical reinforcement bars remaining and extending into the removal areas shall be cleaned, straightened and incorporated into the new construction. Cost included with Concrete Removal.  
 See sheet 5 of 13 for overlay details.  
 See sheet 8 of 13 for Sections.  
 See sheet 9 of 13 for Joint Strip Seal.

**BILL OF MATERIAL**

Bar	No.	Size	Length	Shape
a(E)	16	#5	16'-0"	—
a1(E)	16	#5	18'-0"	—
a2(E)	16	#6	7'-4"	—
a3(E)	8	#5	5'-6"	—
a4(E)	2	#5	3'-7"	—
d(E)	12	#4	5'-3"	L
d1(E)	12	#5	4'-2"	L
d2(E)	8	#5	3'-2"	U
h(E)	8	#6	16'-3"	—
h1(E)	8	#6	18'-3"	—
u(E)	76	#5	2'-3"	U
x(E)	60	#5	2'-8"	L
Item		Unit	Total	
Concrete Removal		Cu. Yd.	9.5	
Concrete Superstructure		Cu. Yd.	10.4	
Reinforcement Bars, Epoxy Coated		Pound	1,660	

**LEGEND**



**CONCRETE REMOVAL PLAN**

(N. Abut. Shown, S. Abut. Similar)

**CONCRETE REPLACEMENT PLAN**

(N. Abut. Shown, S. Abut. Similar)

MODEL: SMODELNAMES  
 FILE NAME: \$FILES



USER NAME = \$USERS\$	DESIGNED - CFS	REVISED -
\$FILESS\$	CHECKED - RPW	REVISED -
PLOT SCALE = \$SCALE\$	DRAWN - JDC	REVISED -
PLOT DATE =	CHECKED - MDC	REVISED -

STATE OF ILLINOIS  
 DEPARTMENT OF TRANSPORTATION

EXPANSION JOINT DETAILS  
 STRUCTURE NO. 029-0021

SHEET 7 OF 13 SHEETS

F.A.P. RTE.	SECTION	COUNTY	TOTAL SHEETS	SHEET NO.
30	(139,138)(BC,BC-1)BR,BR-1)BRR	FULTON	119	113
CONTRACT NO. 68H20				
ILLINOIS FED. AID PROJECT				

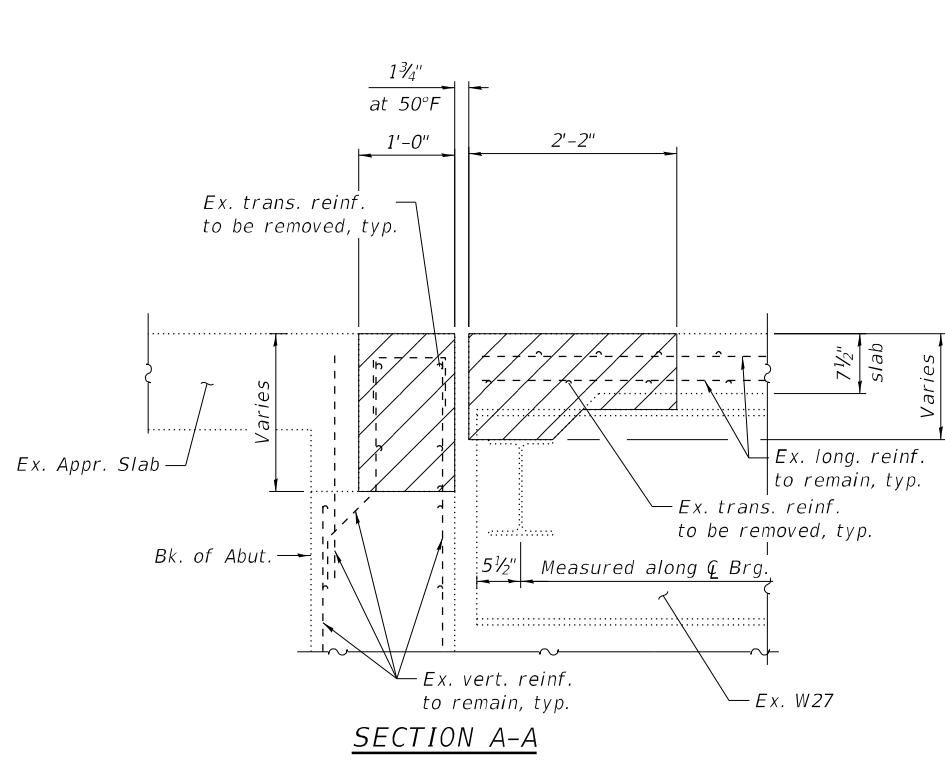

**SECTION A-A**

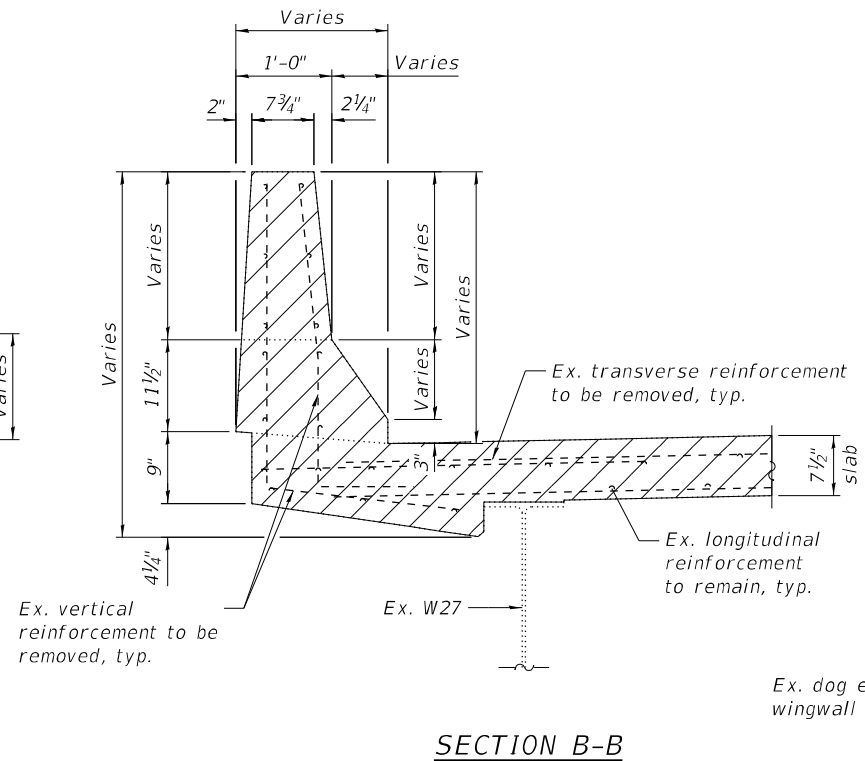

**SECTION B-B**

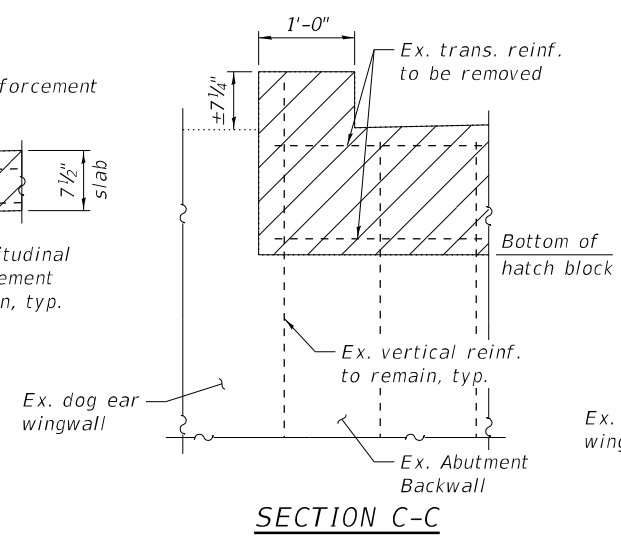

**SECTION C-C**

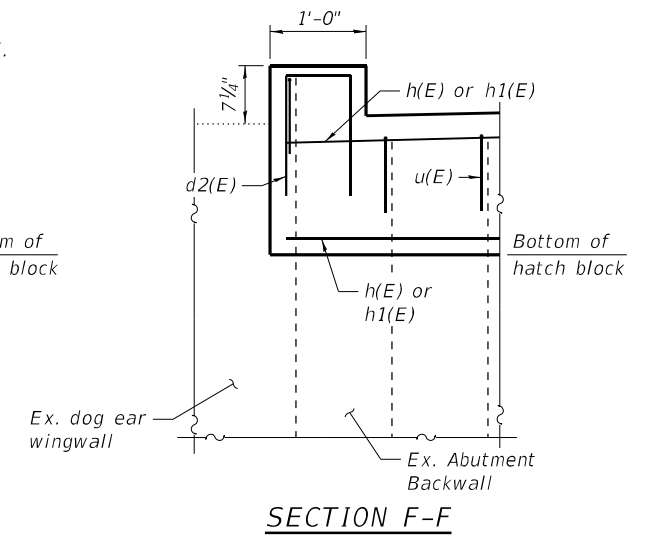

**SECTION F-F**

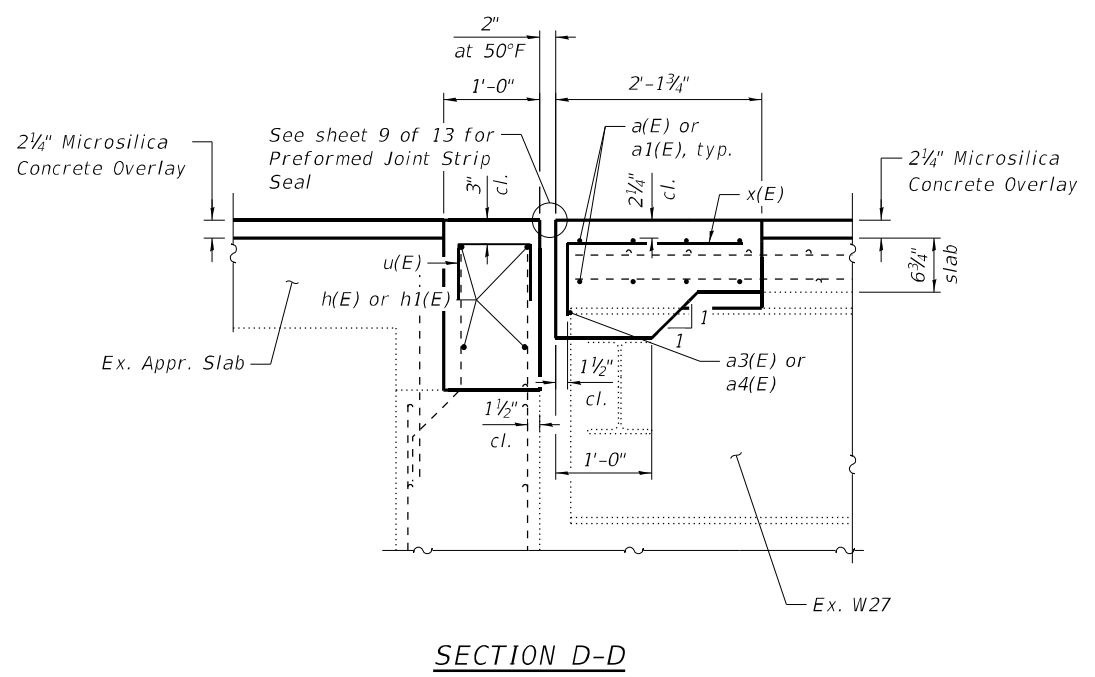

**SECTION D-D**

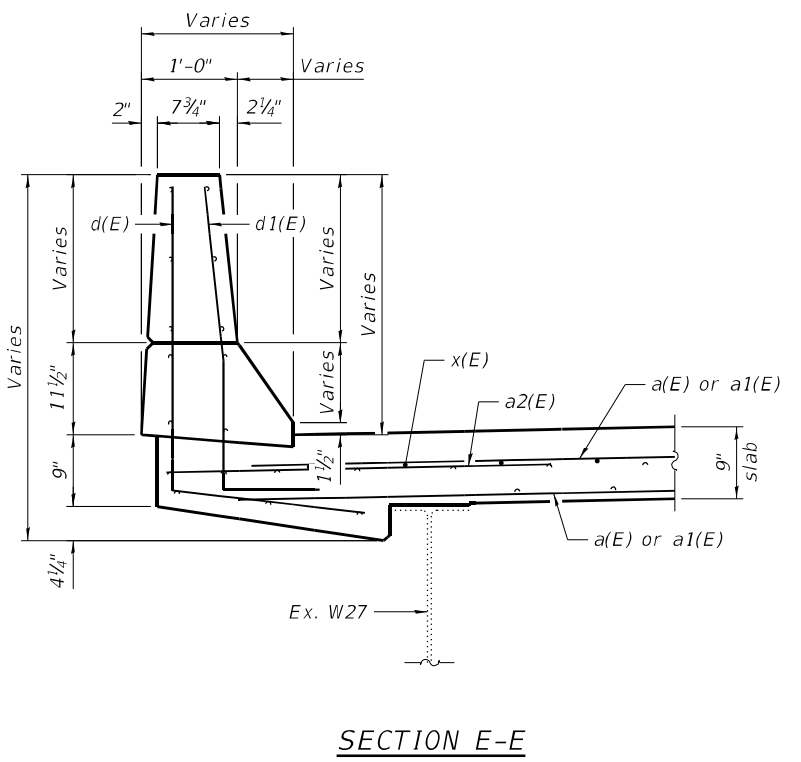

**SECTION E-E**

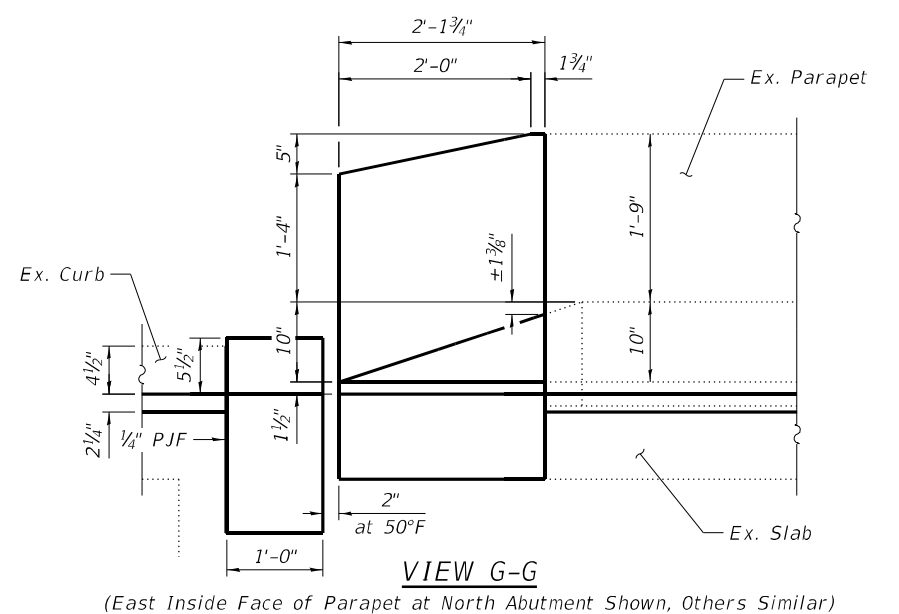

**VIEW G-G**

(East Inside Face of Parapet at North Abutment Shown, Others Similar)

**LEGEND**



Notes:  
See sheet 7 of 13 for Bill of Material, section locations and additional details.  
See sheet 5 of 13 for overlay details.

MODEL: SMODELNAMES  
FILE NAME: SFILES



USER NAME = \$USERS\$	DESIGNED - CFS	REVISED -
\$FILES\$	CHECKED - RPW	REVISED -
PLOT SCALE = \$\$SCALE\$	DRAWN - JDC	REVISED -
PLOT DATE =	CHECKED - MDC	REVISED -

**STATE OF ILLINOIS  
DEPARTMENT OF TRANSPORTATION**

**EXPANSION JOINT DETAILS  
STRUCTURE NO. 029-0021**

SHEET 8 OF 13 SHEETS

F.A.P. RTE.	SECTION	COUNTY	TOTAL SHEETS	SHEET NO.
30	[139,138(BC;BC-1)BR,BR-1]BRR	FULTON	119	114
CONTRACT NO. 68H20				
ILLINOIS FED. AID PROJECT				

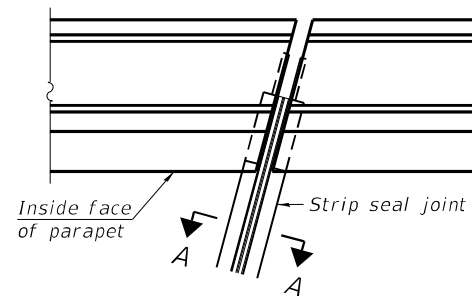

FOR SKEWS  $\leq 30^\circ$

PLAN AT PARAPET

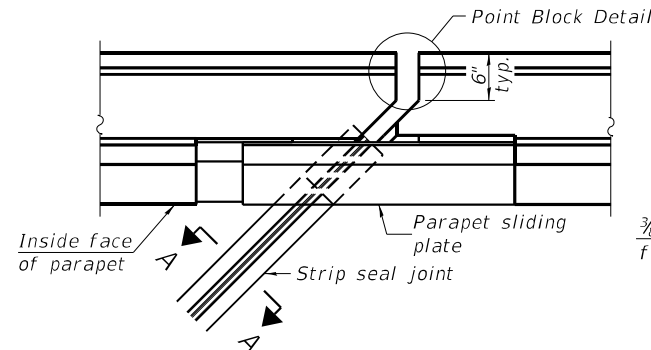

FOR SKEWS  $> 30^\circ$

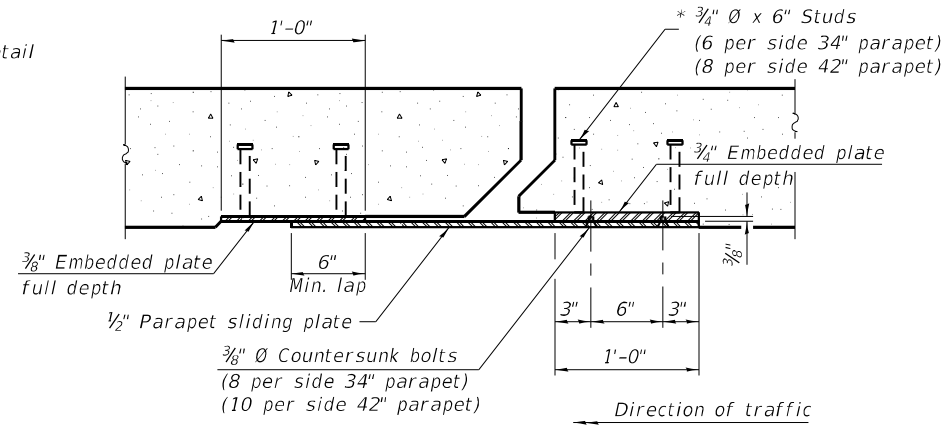

SECTION B-B

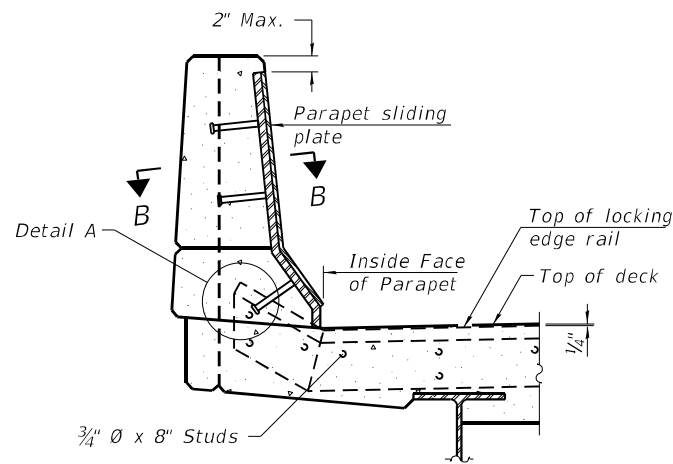

ELEVATION AT PARAPET

(Skews  $> 30^\circ$  shown. Skews  $\leq 30^\circ$  similar except as shown in plan view.)

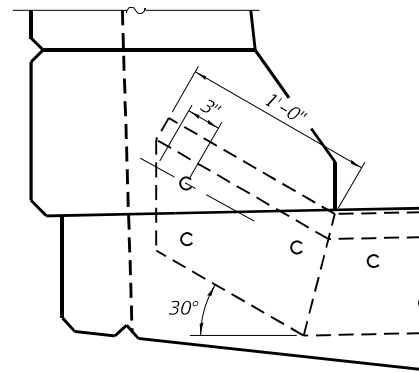

DETAIL A

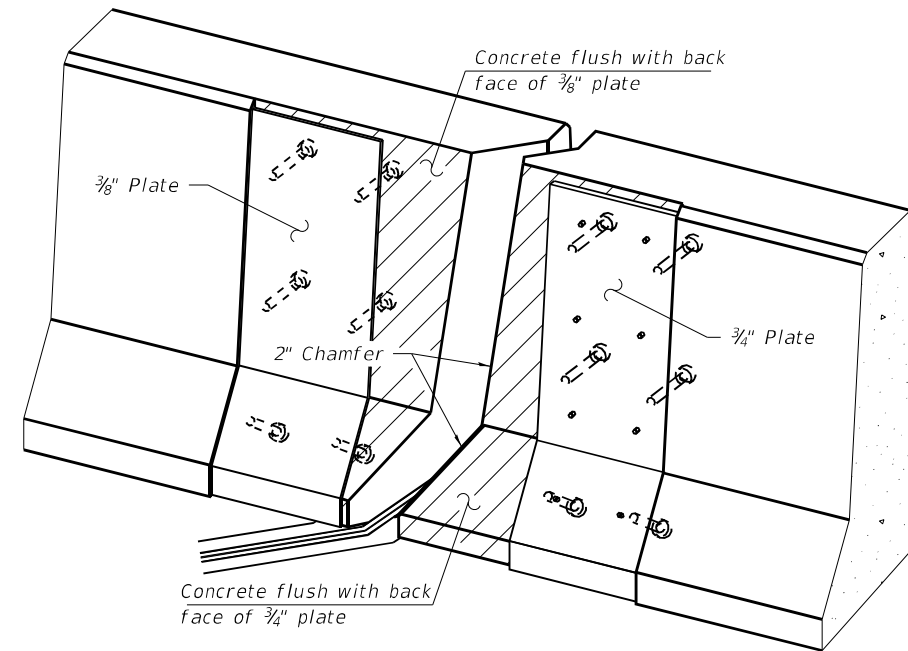

TRIMETRIC VIEW  
(Showing embedded plates only)

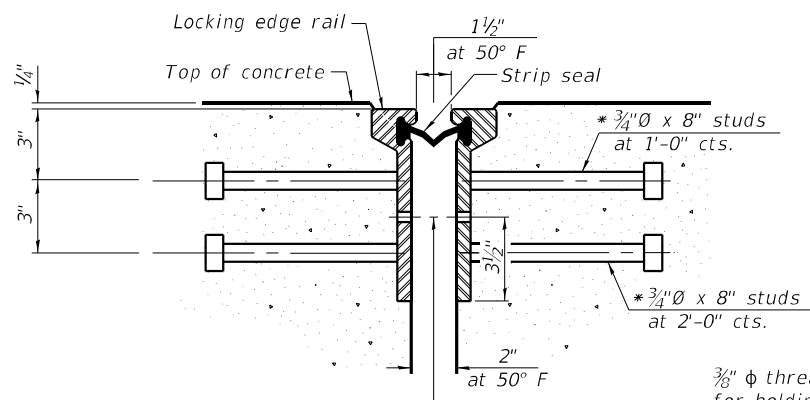

SHOWING ROLLED RAIL JOINT

$3/8$ "  $\phi$  threaded rods in  $7/16$ "  $\phi$  holes at  $\pm 4$ "-0" cts. for holding the proper joint opening based on the temperature during the deck pour. Place to miss studs. All rods shall be burned, or sawed off flush with the plates after concrete is set.

SECTION A-A

\* Granular or solid flux filled headed studs conforming to Article 1006.32 of the Std. Specs., automatically end welded.

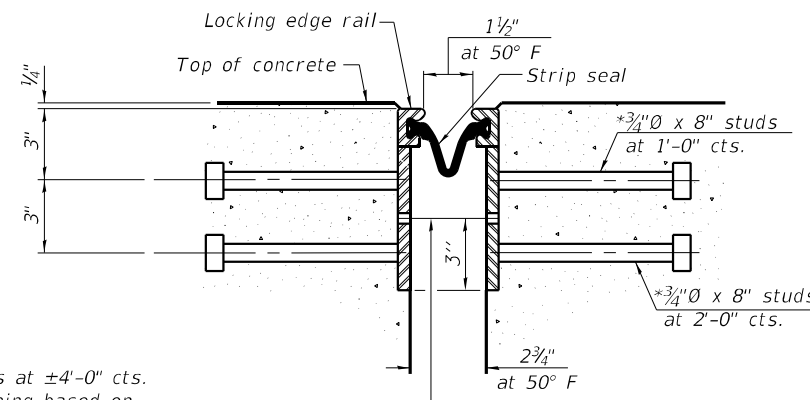

SHOWING WELDED RAIL JOINT

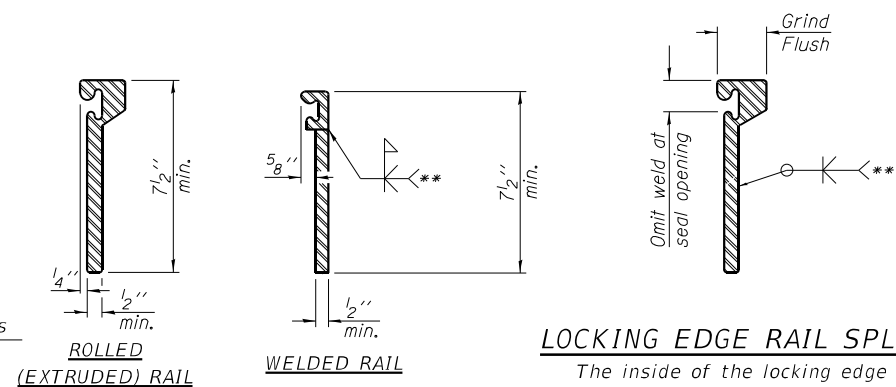

LOCKING EDGE RAILS

\*\* Back gouge not required if complete joint penetration is verified by mock-up.

LOCKING EDGE RAIL SPLICE

The inside of the locking edge rail groove shall be free of weld residue. Rolled rail shown, welded rail similar.

BILL OF MATERIAL

Item	Unit	Total
Preformed Joint Strip Seal	Foot	66

EJ-SS (TALL WITH GUTTER)

10-1-19

STATE OF ILLINOIS  
DEPARTMENT OF TRANSPORTATION

PREFORMED JOINT STRIP SEAL  
STRUCTURE NO. 029-0021

SHEET 9 OF 13 SHEETS

F.A.P. RTE.	SECTION	COUNTY	TOTAL SHEETS	SHEET NO.
30	[139,138/BC/BC-1]BR, BR-1]BRR	FULTON	119	115
CONTRACT NO. 68H20				
ILLINOIS FED. AID PROJECT				

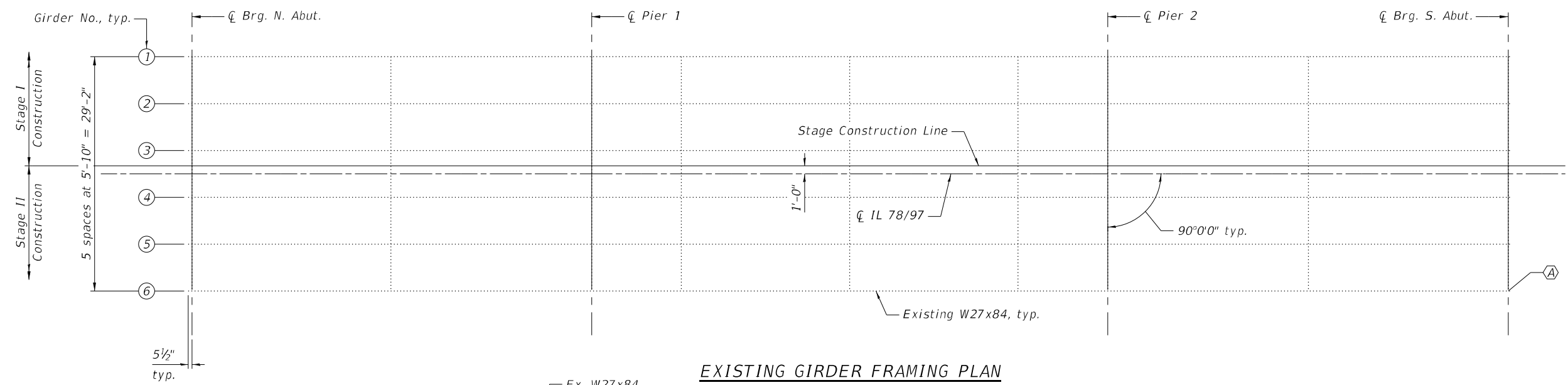
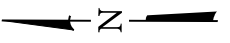

**EXISTING GIRDER FRAMING PLAN**

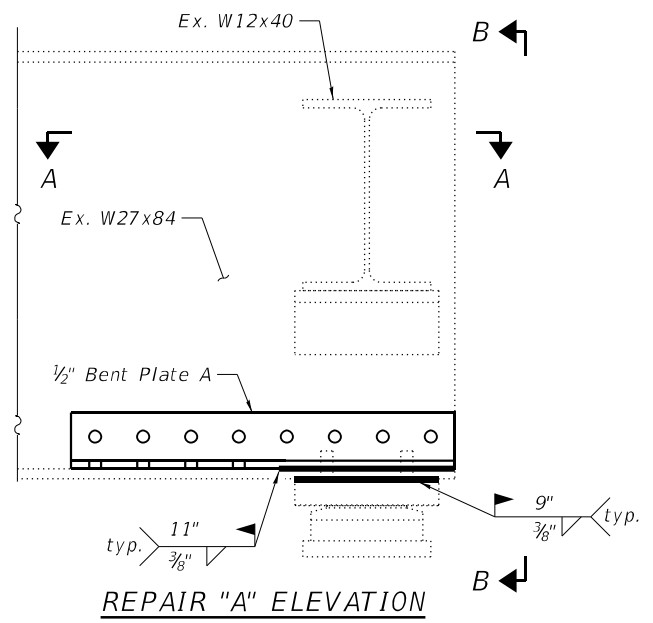

**REPAIR "A" ELEVATION**

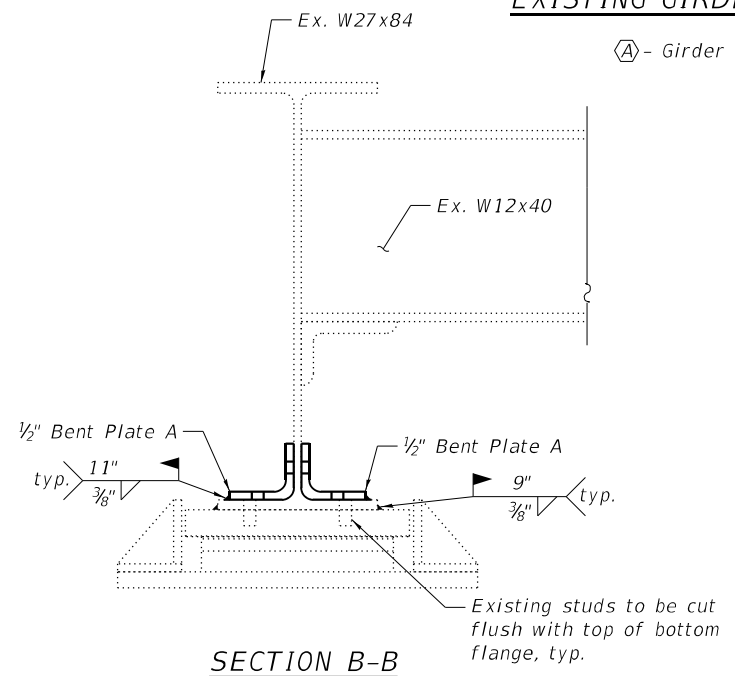

**SECTION B-B**

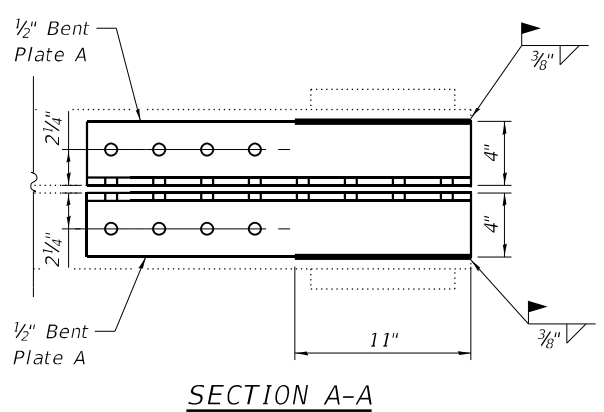

**SECTION A-A**

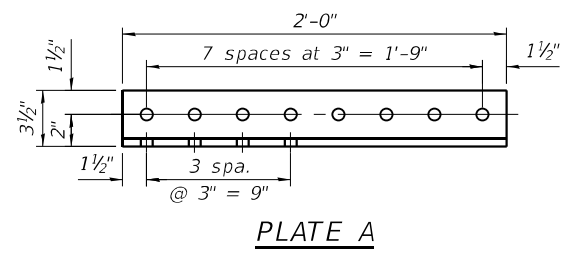

**PLATE A**

**Notes:**  
 All structural steel shall be AASHTO M270 Grade 50, unless otherwise noted.  
 All repair materials including structural steel plates, bolts, nuts, and washers shall be galvanized per the special provision "Hot Dip Galvanizing for Structural Steel". Cost included in Structural Steel Repair.  
 Fasteners shall be ASTM A325 Type 1, mechanically galvanized bolts. Bolts 3/4" Ø, holes 13/16" Ø, unless otherwise noted.  
 Existing structural steel that will be in contact with new structural steel shall be cleaned and painted prior to erection as required by the special provision "Cleaning and Painting Contact Surface Areas of Existing Steel Structures".  
 Use holes in new steel as template to field drill holes in existing steel.  
 Plan dimensions and details relative to existing plans are subject to nominal construction variations. The Contractor shall field verify existing dimensions and details affecting new construction and make necessary approved adjustments prior to construction or ordering of materials. Such variations shall not be caused for additional compensation for change in scope of the work, however, the Contractor will be paid for the quantity actually furnished at the unit price bid for the work.  
 No field welding is permitted except as specified in the contract documents.

**BILL OF MATERIAL**

Item	Unit	Total
Structural Steel Repair	Pound	60

MODEL: SMODELNAMES  
 FILE NAME: \$FILES



USER NAME = \$USERS\$	DESIGNED - CFS	REVISED -
\$FILES\$	CHECKED - RPW	REVISED -
PLOT SCALE = \$SCALE\$	DRAWN - JDC	REVISED -
PLOT DATE =	CHECKED - MDC	REVISED -

**STATE OF ILLINOIS  
 DEPARTMENT OF TRANSPORTATION**

**BEAM END REPAIRS  
 STRUCTURE NO. 029-0021**

SHEET 10 OF 13 SHEETS

F.A.P. RTE.	SECTION	COUNTY	TOTAL SHEETS	SHEET NO.
30	[139,138](BC,BC-1)BR,BR-1)BRR	FULTON	119	116
CONTRACT NO. 68H20				
ILLINOIS FED. AID PROJECT				

SDATE\$ \$TIMES\$

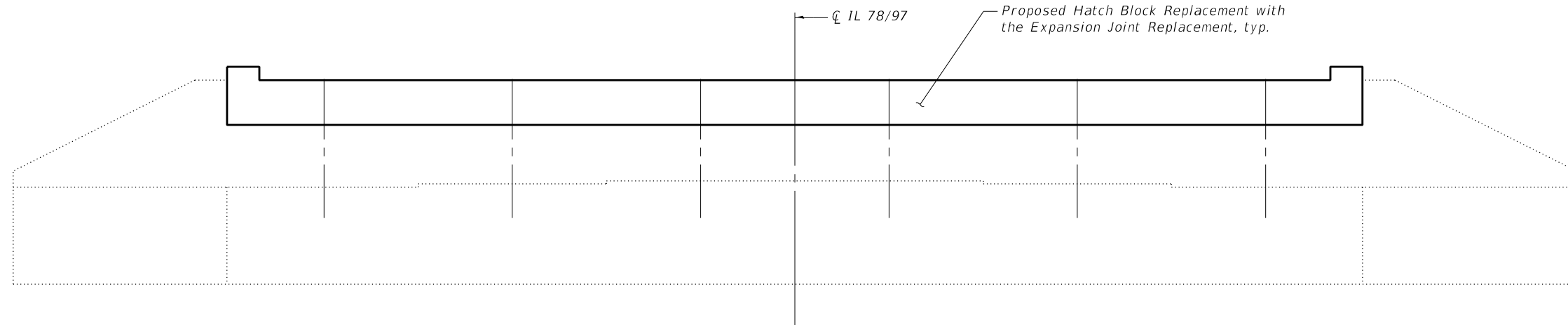

**NORTH ABUTMENT ELEVATION**  
(Looking North)

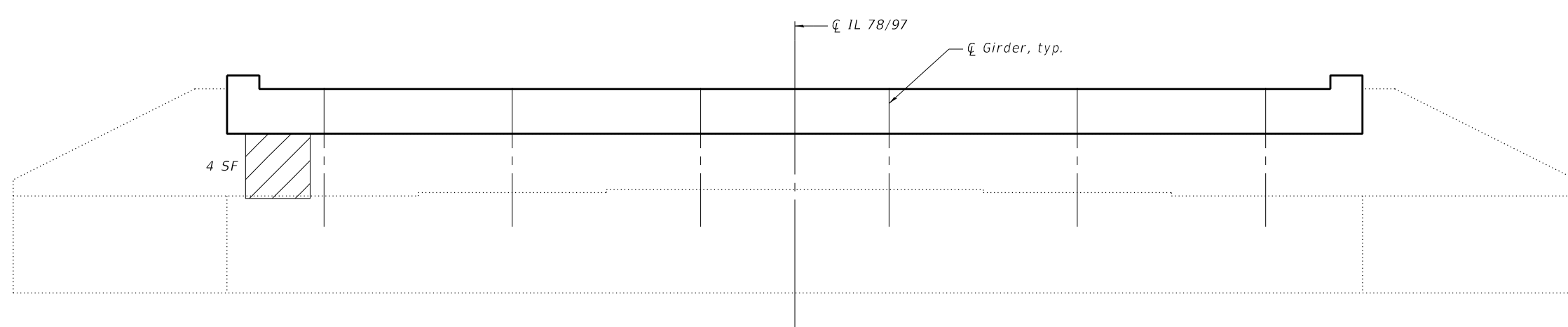

**SOUTH ABUTMENT ELEVATION**  
(Looking South)

*Note:*  
For wingwall and hatch block details with the expansion joint replacement, see sheets 7 and 8 of 13.

**LEGEND**

 Structural Repair of Concrete (Depth Equal to or less than 5")

**BILL OF MATERIAL**

Item	Unit	Total
Structural Repair of Concrete (Depth Equal to or Less Than 5")	Sq. Ft.	4

MODEL: \$MODELNAME\$  
FILE NAME: \$FILES



USER NAME = \$USER\$	DESIGNED - CFS	REVISED -
\$FILE\$	CHECKED - RPW	REVISED -
PLOT SCALE = \$SCALE\$	DRAWN - JDC	REVISED -
PLOT DATE =	CHECKED - MDC	REVISED -

**STATE OF ILLINOIS  
DEPARTMENT OF TRANSPORTATION**

**ABUTMENT REPAIRS  
STRUCTURE NO. 029-0021**

SHEET 11 OF 13 SHEETS

F.A.P. RTE.	SECTION	COUNTY	TOTAL SHEETS	SHEET NO.
30	[139,138(BC;BC-1)BR,BR-1]BRR	FULTON	119	117
CONTRACT NO. 68H20				
ILLINOIS FED. AID PROJECT				

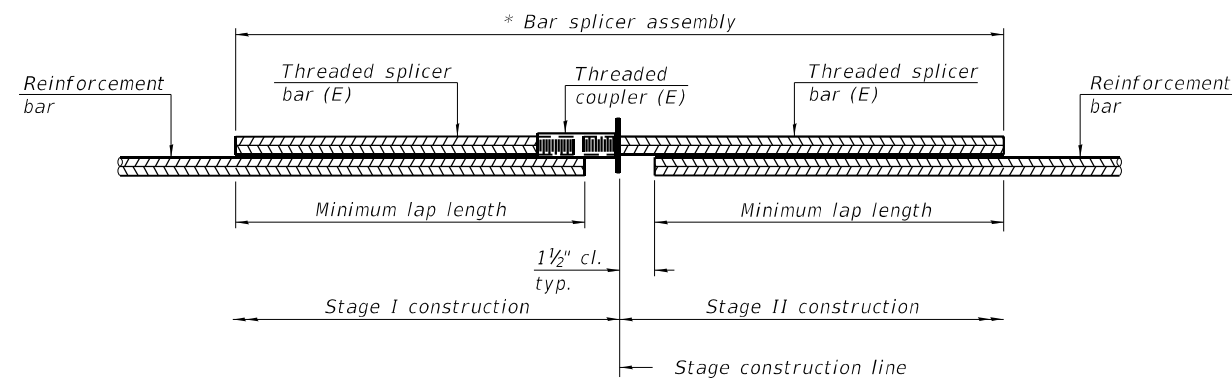

**STANDARD BAR SPLICER ASSEMBLY PLAN**

Only bar splicer assemblies as presented on the approved QPL list may be used.

Threaded splicer bar length = min. lap length + 1 1/2" + thread length

\* Epoxy not required on Bar Splicer Assembly components used in conjunction with black bars.

Location	Bar size	No. assemblies required	Minimum lap length
Bridge Deck Side of Exp. Jt.	#5	18	3'-4"
Appr. Side of Exp. Jt.	#6	8	4'-0"

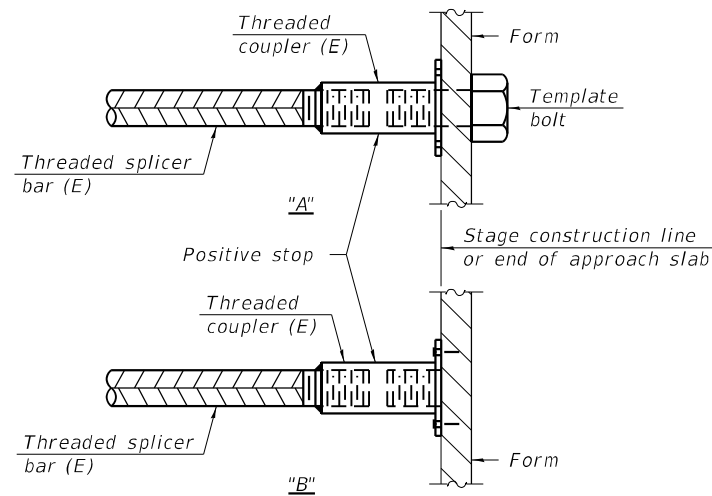

**INSTALLATION AND SETTING METHODS**

"A" : Set bar splicer assembly by means of a template bolt.

"B" : Set bar splicer assembly by nailing to wood forms or cementing to steel forms.

(E) : Indicates epoxy coating.

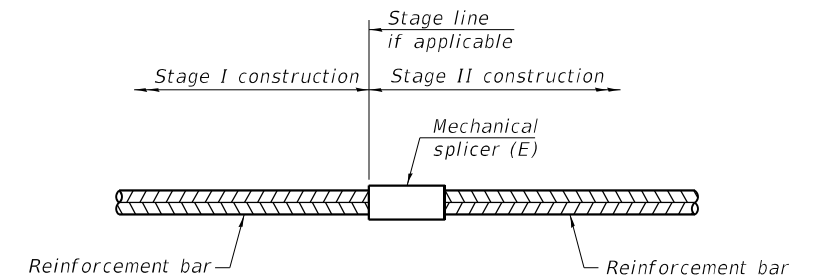

**STANDARD MECHANICAL SPLICER**

Location	Bar size	No. assemblies required

**Notes:**

Splicer bars shall be deformed with threaded ends and have a minimum 60 ksi yield strength.

All reinforcement shall be lapped and tied to the splicer bars.

Bar splicer assemblies shall be epoxy coated according to the requirements for reinforcement bars. See Section 508 of the Standard Specifications.

See approved list of bar splicer assemblies and mechanical splicers for alternatives.

MODEL: \$MODELNAME\$  
FILE NAME: \$FILES\$

BSD-1

2-1-2023



USER NAME = \$USERS\$	DESIGNED - CFS	REVISED -
\$FILES\$	CHECKED - RPW	REVISED -
PLOT SCALE = \$SCALE\$	DRAWN - JDC	REVISED -
PLOT DATE =	CHECKED - MDC	REVISED -

STATE OF ILLINOIS  
DEPARTMENT OF TRANSPORTATION

BAR SPLICER ASSEMBLY AND MECHANICAL SPLICER DEALS  
STRUCTURE NO. 029-0021

SHEET 12 OF 13 SHEETS

F.A.P. RTE.	SECTION	COUNTY	TOTAL SHEETS	SHEET NO.
30	[139,138(BC;BC-1)BR,BR-1]BRR	FULTON	119	118
CONTRACT NO. 68H20				
ILLINOIS FED. AID PROJECT				

ROUTE NO.	SECTION	COUNTY	TOTAL SHEETS	SHEET NO.
F.A.P. 30	(139BC)BR	FULTON	86	71
FED. ROAD DIST. NO. 7 ILLINOIS FED. AID PROJECT				

SHEET NO. 7  
14 SHEETS

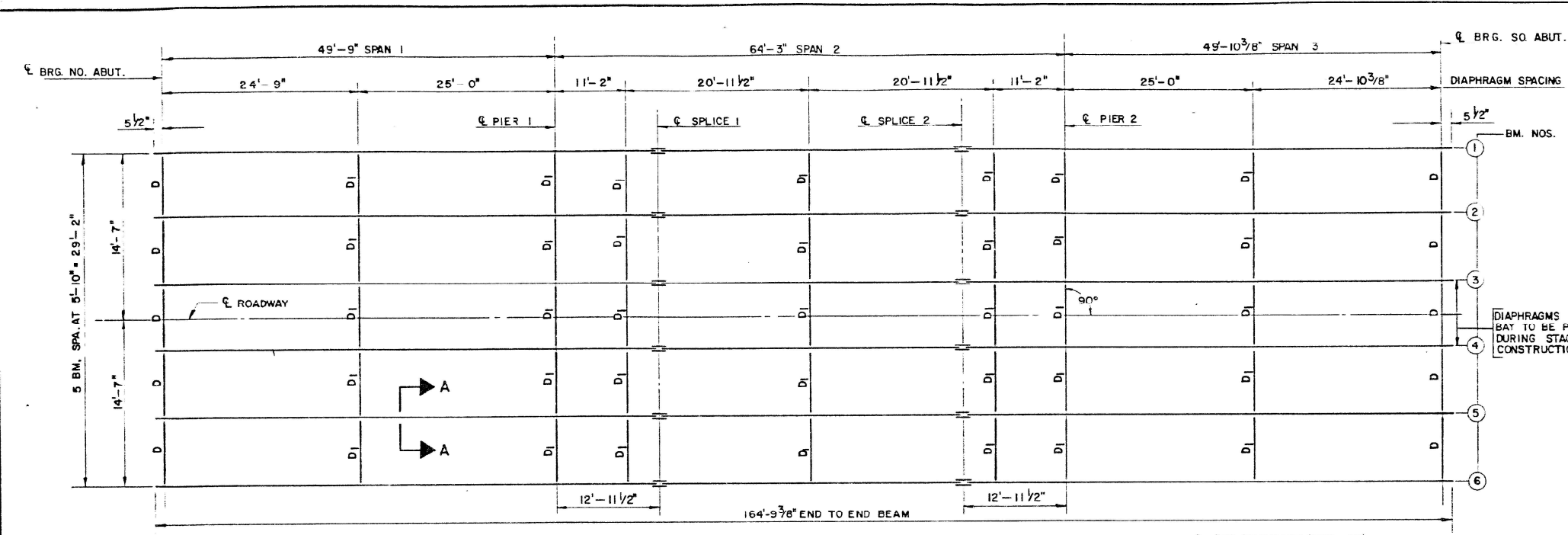

FRAMING PLAN

D- END DIAPHRAGM (W12 x 40)  
D1- INTERIOR DIAPHRAGM (W10 x 26)

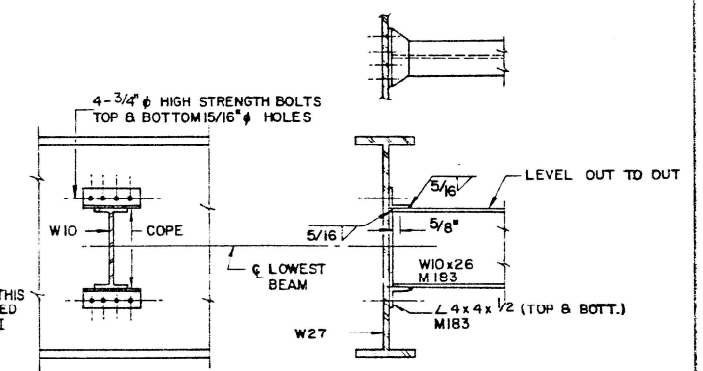

INTERIOR DIAPHRAGM D1  
(35 REQUIRED)

NOTE: HARDENED WASHERS SHALL BE REQUIRED OVER ALL HOLES IN DIAPHRAGM CONNECTIONS.

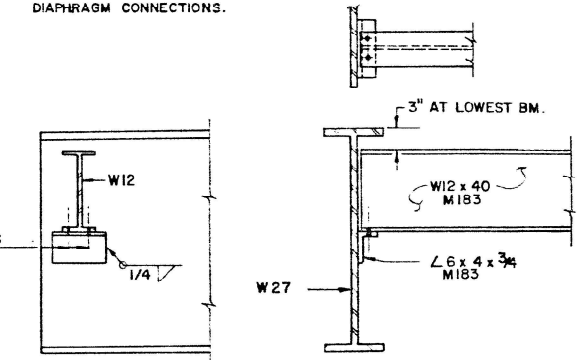

END DIAPHRAGM D  
(10 REQUIRED)

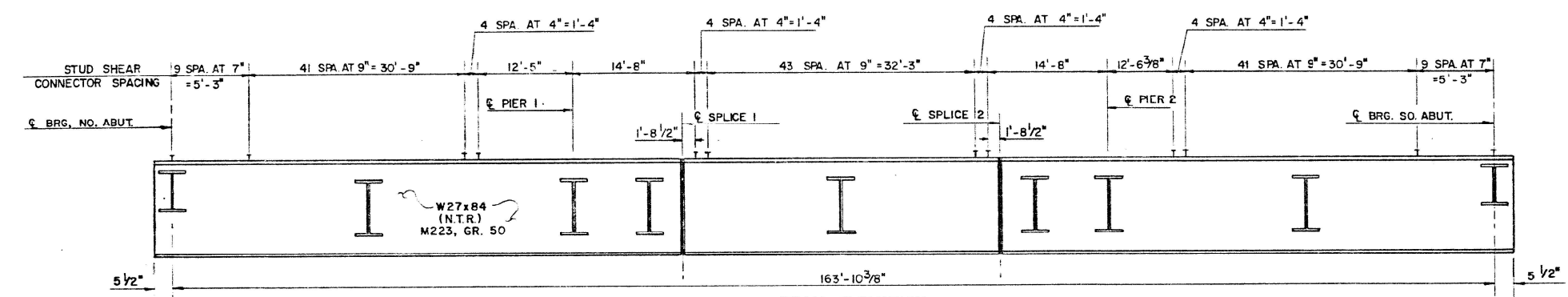

BEAM ELEVATION

N.T.R. = NOTCH TOUGHNESS REQUIREMENTS

NOTE: ALL STRUCTURAL STEEL FABRICATORS PERFORMING WORK ON THE MAIN LOAD CARRYING COMPONENTS OF STEEL STRUCTURES SHALL BE CERTIFIED UNDER CATEGORY III (AISC) OF THE QUALITY CERTIFICATION PROGRAM.

\* FOR FABRICATION ONLY

	℄ OF NO. ABUT.	℄ OF PIER 1	℄ OF SPLICE 1	℄ OF SPLICE 2	℄ OF PIER 2	℄ OF SQ. ABUT.
BM #1	451.87	451.93	451.95	451.95	451.93	451.87
BM #2	451.98	452.04	452.06	452.06	452.04	451.98
BM #3	452.07	452.13	452.15	452.15	452.13	452.07
BM #4	452.07	452.13	452.15	452.15	452.13	452.07
BM #5	451.98	452.04	452.06	452.06	452.04	451.98
BM #6	451.87	451.93	451.95	451.95	451.93	451.87

INTERIOR BEAM MOMENT TABLE			
ITEM		0.4 SPAN 1 OR 3 PIER 1 OR 2	0.5 SPAN 2
$I_s$	(in <sup>4</sup> )	2850	2850
$I_c$	n=27 (in <sup>4</sup> )	6129	6129
$I_c$	n=9 (in <sup>4</sup> )	8214	8214
$S_s$	(in <sup>3</sup> )	213	213
$S_c$	n=27 (in <sup>3</sup> )	293	293
$S_c$	n=9 (in <sup>3</sup> )	323	323
$R$	(k/ft)	0.650	0.940
$M_R$	(k)	108	120
$S_R$	(k/ft)	0.290	0.290
$M_{S_R}$	(k)	57	76
$M_L$	(k)	265	164
$M_{Imp}$	(k)	82	45
$5/3(M_L + I)$	(k)	612	349
$M_o$	(k)	1010	832
$M_u$	(k)	—	—
$f_s R$	non-comp (k.s.i.)	6.1	16.4
$f_s R$	(comp) n=27 (k.s.i.)	2.4	—
$f_s 5/3(L + I)n=9$	(k.s.i.)	22.8	19.7
$f_s$	(Overload) (k.s.i.)	31.3	36.1
$f_s$	(Total) (k.s.i.)	40.7	47.4
$VR$	(K)	42.50	36.50

INTERIOR BEAM REACTION TABLE		
ITEM	ABUTMENT	PIER
$R_R$	(k)	18.0
$R_L$	(k)	30.5
$Imp$	(k)	8.0
$R$ TOTAL	(k)	57.5

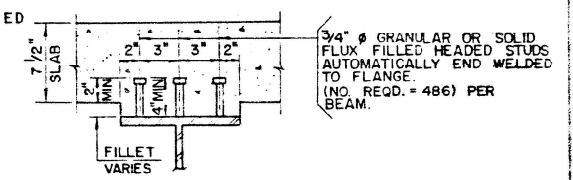

SECTION A-A

NOTES  
NOTCH TOUGHNESS REQUIREMENTS ARE REQUIRED FOR ALL SPLICE PLATES AND WIDE FLANGE BEAMS (W27 x 84)

$M_u$  = FULL PLASTIC MOMENT CAPACITY FOR COMPACT, BRACED SECTION  
 $M_o$  (APPLIED MOMENT) =  $1.3 [M_R + M_S R + 5/3 (M_L + I)]$   
 $I_s$  AND  $S_s$  ARE THE MOMENT OF INERTIA AND SECTION MODULUS OF THE STEEL SECTION USED IN COMPUTING  $f_s$  (OVERLOAD).  
 $I_c$  AND  $S_c$  ARE THE MOMENT OF INERTIA AND SECTION MODULUS OF THE COMPOSITE SECTION USED IN COMPUTING  $f_s$  (OVERLOAD).  
 $V_R$  IS THE MAXIMUM  $L + IMPACT$  SHEAR RANGE IN SPAN.  
 THE FULLY PLASTIC MOMENT CAPACITY ( $M_u$ ) IS COMPUTED ACCORDING TO AASHTO 10.50.1  
 $f_s$  (TOTAL) IS THE SUM OF THE STRESSES DUE TO  $1.3 [M_R + M_S R + 5/3 (M_L + I)]$ , COMPUTED ACCORDING TO AASHTO 10.50.1  
 $f_s$  (OVERLOAD) IS THE SUM OF THE STRESSES DUE TO  $M_R + M_S R + 5/3 (M_L + I)$ .  
 \* THESE VALUES ARE SERVICE LOAD.

**WELLS ENGINEERS, INC.**  
 FRAMING PLAN AND DETAILS  
 IL ROUTES 78 & 97  
 OVER LACY DITCH  
 F.A.P. ROUTE 30 SEC (139BC)BR  
 STA 535+83.14  
 FULTON COUNTY  
 STRUCTURE NO. 029-0021  
 DATE: 3-30-87 DRAWN BY: GLH JOB NO. 860672  
 DESIGNED BY: SDK CHECKED BY: KRP SHEET NO. 7 OF 14

FOR INFORMATION ONLY

MODEL: SMODELNAMES  
FILE NAME: \$FILES

**QEI**  
 QUIGG ENGINEERING INC

USER NAME = \$USERS	DESIGNED - CFS	REVISED -
\$FILES	CHECKED - RPW	REVISED -
PLOT SCALE = \$SCALE	DRAWN - JDC	REVISED -
PLOT DATE =	CHECKED - MDC	REVISED -

STATE OF ILLINOIS  
 DEPARTMENT OF TRANSPORTATION

EXISTING PLANS REFERENCE SHEET  
 STRUCTURE NO. 029-0021

SHEET 13 OF 13 SHEETS

F.A.P. RTE.	SECTION	COUNTY	TOTAL SHEETS	SHEET NO.
30	(139,138/BC/BC-1)BR, BR-1)BR	FULTON	119	119
CONTRACT NO. 68H20				
ILLINOIS FED. AID PROJECT				