

**PERMANENT LANE CLOSURE - STAGE 1**

WESTBOUND SHOWN - EASTBOUND SIMILAR  
STA 544+47 TO STA 700+00

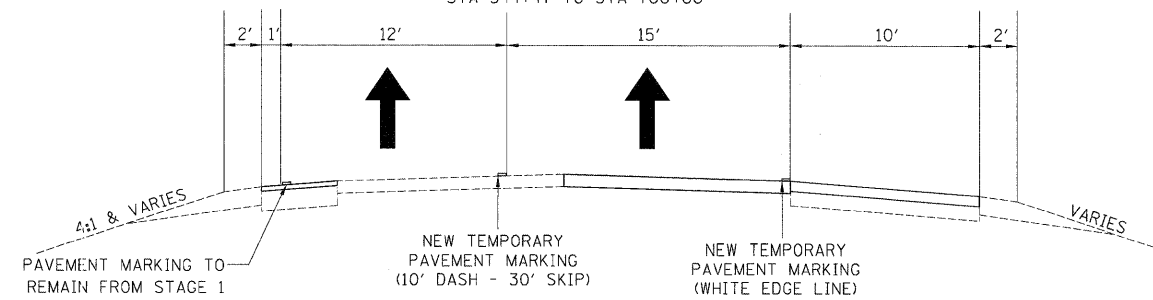

**INTERMITTENT STRIPING - (JULY 1, 2011 THROUGH JULY 11, 2011)**

WESTBOUND SHOWN - EASTBOUND SIMILAR  
STA 544+47 TO STA 700+00

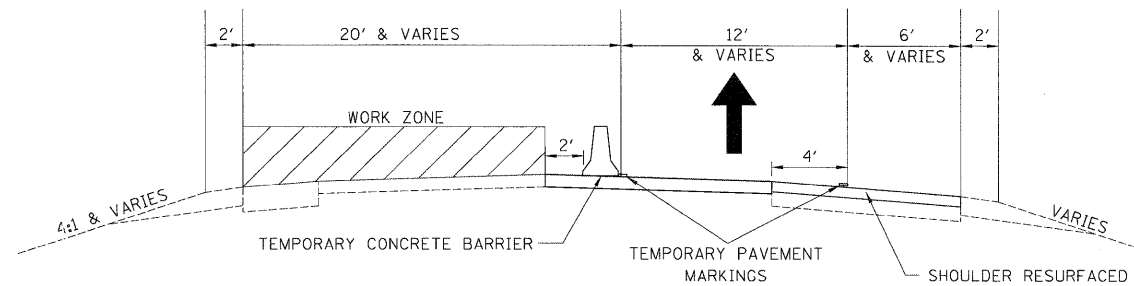

**PERMANENT LANE CLOSURE - STAGE 2**

WESTBOUND SHOWN - EASTBOUND SIMILAR  
STA 544+47 TO STA 700+00

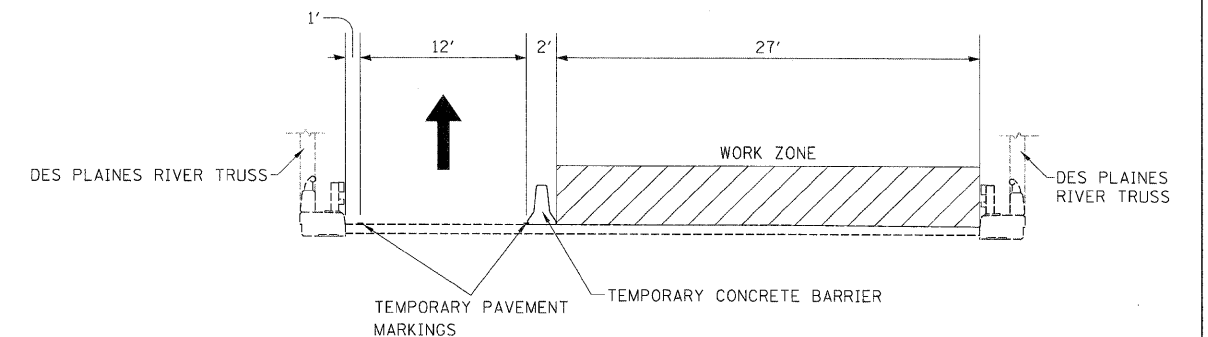

**STAGE 1 CONSTRUCTION FOR WB I-80 OVER  
DES PLAINES RIVER, BNSF RAILROAD/GARDNER STREET, AND HICKORY CREEK  
LOOKING WEST**

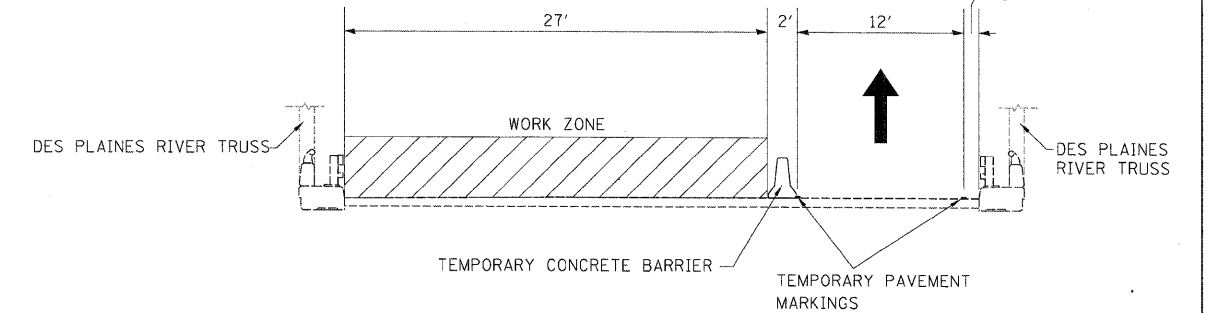

**STAGE 2 CONSTRUCTION FOR WB I-80 OVER  
DES PLAINES RIVER, BNSF RAILROAD/GARDNER STREET, AND HICKORY CREEK  
LOOKING WEST**

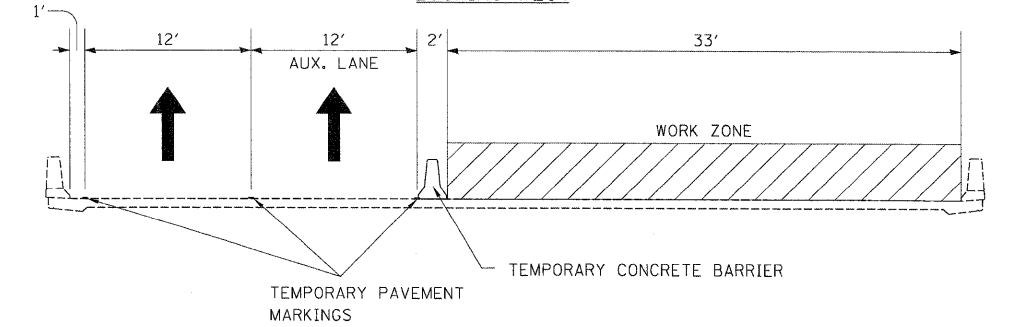

**STAGE 1 CONSTRUCTION FOR WB I-80 OVER CHICAGO STREET  
LOOKING WEST**

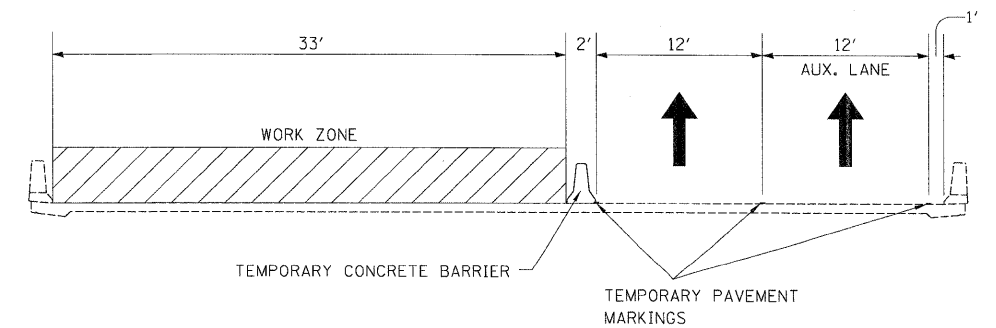

**STAGE 2 CONSTRUCTION FOR WB I-80 OVER CHICAGO STREET  
LOOKING WEST**

**MAINTENANCE OF TRAFFIC GENERAL NOTES:**

1. REMOVAL OF EXISTING PAVEMENT MARKING, WHEN REQUIRED, SHALL BE PAID FOR AS "PAVEMENT MARKING REMOVAL".
2. EXISTING PAVEMENT MARKINGS REMOVED DURING MILLING OPERATIONS WILL NOT BE PAID FOR SEPARATELY.
3. PRESTAGE WORK WILL BE PERFORMED UNDER TEMPORARY NIGHTTIME LANE CLOSURES UTILIZING IDOT HIGHWAY STANDARD 701400-05 AND 701401-06 FOR SINGLE LANE CLOSURES FOLLOWING ALL APPLICABLE CONTRACT REQUIREMENTS. THESE CLOSURES WILL BE INCLUDED IN THE LUMP SUM ITEM "TRAFFIC CONTROL AND PROTECTION, (EXPRESSWAYS)".
4. SHOULDER RUMBLE STRIPS SHALL BE INSTALLED AFTER THE PERMANENT MAINTENANCE OF TRAFFIC HAS BEEN REMOVED. THIS WORK SHALL BE UNDER A SHOULDER CLOSURE ACCORDING TO IDOT DISTRICT 1 STANDARD DRAWING TC-17 .
5. SURFACE COURSE SHALL ONLY BE APPLIED WHEN CONTRACTOR IS ABLE TO PROPERLY INSTALL PERMANENT INLAID STRIPING. COVERING OF PERMANENT STRIPING WITH BLACK TAPE OR SUBSEQUENT GROOVING OF THE PAVEMENT WILL NOT BE ALLOWED.
6. DURING INTERMITTENT STAGE, ALL SIGNS SHALL BE MODIFIED TO PROPERLY REFLECT TRAFFIC CONFIGURATION.
7. CONTRACTOR SHALL BE RESPONSIBLE FOR PROVIDING AND PLACING WIDTH RESTRICTION SIGNING ACCORDING TO IDOT'S "ROAD CONSTRUCTION REPORTING AND SIGNING FOR VEHICLE WIDTH RESTRICTIONS" POLICY. THIS WORK WILL BE INCLUDED IN "TRAFFIC CONTROL AND PROTECTION (EXPRESSWAYS)" (X7011015).

**MAINTENANCE OF TRAFFIC STAGING DESCRIPTION:**

- PRESTAGE -**
1. GRIND AND RESURFACE INSIDE SHOULDER TO REMOVE RUMBLE STRIP. STA 526+00 TO 700+00
- STAGE 1 -**
1. GRIND, PATCH, AND RESURFACE OUTSIDE LANE AND SHOULDER. SEE ROADWAY PLANS FOR SPECIFIC LOCATIONS.
  2. COMPLETE ALL STAGE 1 BRIDGE WORK. SEE STRUCTURAL PLANS FOR PROPOSED BRIDGE WORK.
- STAGE 2 -**
1. GRIND, PATCH, AND RESURFACE INSIDE LANE AND SHOULDER. SEE ROADWAY PLANS FOR SPECIFIC LOCATIONS.
  2. COMPLETE ALL STAGE 2 BRIDGE WORK. SEE STRUCTURAL PLANS FOR PROPOSED BRIDGE WORK.

DESIGNED - JK	REVISED -		<b>STATE OF ILLINOIS DEPARTMENT OF TRANSPORTATION</b>	<b>MOT TYPICAL SECTIONS I-80 MAINLINE</b>		F.A.T. RTE.	SECTION	COUNTY	TOTAL SHEETS	SHEET NO.		
DRAWN - JK	REVISED -			SCALE: N/A	SHEET NO. 1 OF 1 SHEETS	STA.	TO STA.	80	99(2&3)RS-3	WILL	200	33
CHECKED - RR	REVISED -			DATE - 01/21/2011	REVISED -	CONTRACT NO. 60M64 FED. ROAD DIST. NO.   ILLINOIS FED. AID PROJECT						

FILE NAME = c:\ecdd\dib\p\p\ros\pgr\eat.lakes\dms34565\0160466-MOT Typ Sec 02.dgn