

EXISTING

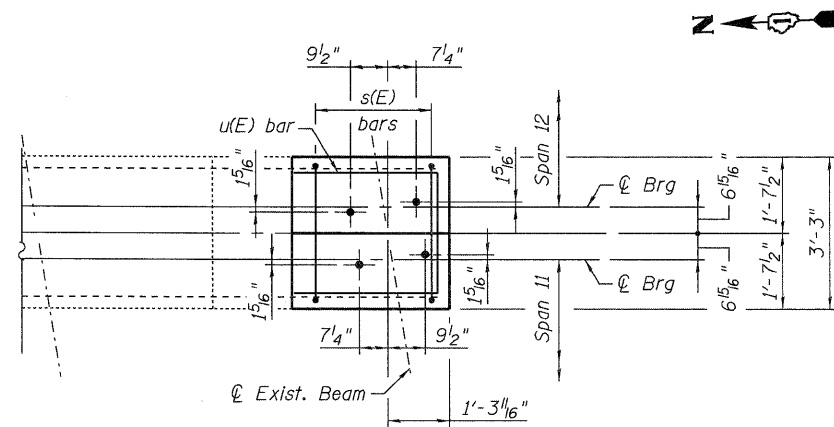

PROPOSED

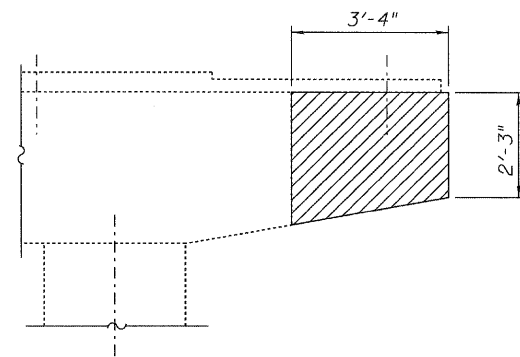

EXISTING

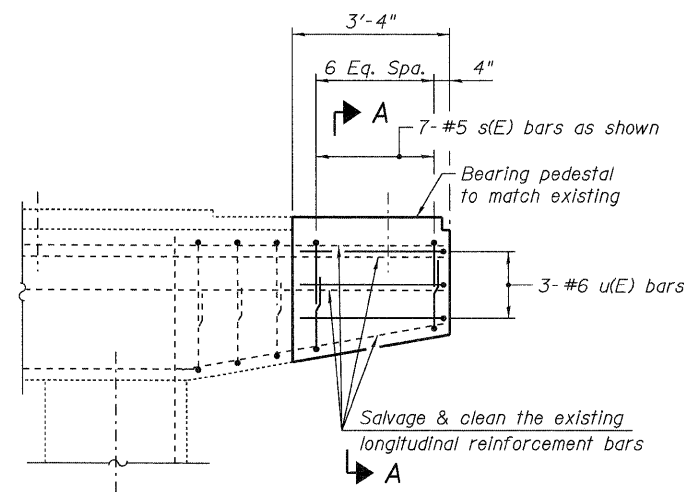

PROPOSED

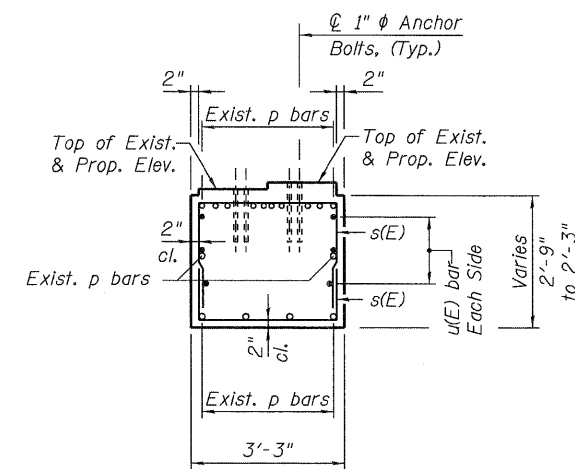

SECTION A-A

BILL OF MATERIAL

Bar	No.	Size	Length	Shape	
s(E)	14	#5	6'-11"	□	
u(E)	3	#6	8'-9"	□	
Reinforcement Bars, Epoxy Coated				Pound	142
Concrete Structures				Cu. Yd.	1.0
Concrete Removal				Cu. Yd.	1.0

BAR s(E)

BAR u(E)

LEGEND:

Concrete Removal

NOTES:

- Space reinforcement in cap to miss anchor bolts.
- Drill holes in cap for anchor bolts and install bolts per the Standard Specifications.

DESIGNED - PCA	REVISED -
USER NAME = laupancheck	DRAWN - LK
PLOT SCALE = 1:1	CHECKED - ML
PLOT DATE = 20-JAN-2011	DATE - 01/21/2011
REVISED -	REVISED -



STATE OF ILLINOIS  
DEPARTMENT OF TRANSPORTATION

PARTIAL PIER CAP 10 REMOVAL & REPLACEMENT  
EASTBOUND FAI-80 OVER RAILROAD/GARDNER STREET  
STRUCTURE NO. 099-0060

F.A.I. RTE.	SECTION	COUNTY	TOTAL SHEETS	SHEET NO.
80	99 (2&3) RS-3	WILL	200	160
FED. ROAD DIST. NO. 1 [ILLINOIS] FED. AID PROJECT			CONTRACT NO. 60M64	

SHEET NO. 5-12 OF 15 SHEETS