

INDEX OF SHEETS

SHEET NO.	DESCRIPTION
1	TITLE SHEET & SUMMARY OF QUANTITIES
2	PLAN & PROFILE, TYPICAL SECTIONS, GENERAL NOTES & STONE RIPRAP DITCH DESIGN
3-4	ROADWAY CROSS SECTIONS
5-13	BRIDGE DESIGN

THE FOLLOWING STANDARDS ARE A PART OF THESE PLANS AND ARE INCLUDED IN THE PROPOSAL:

000001-06	STANDARD SYMBOLS, ABBREVIATIONS & PATTERNS
280001-05	TEMPORARY EROSION CONTROL SYSTEMS
515001-03	NAME PLATE FOR BRIDGES
701901-01	TRAFFIC CONTROL DEVICES
B.L.R. 21-8	TYPICAL APPLICATION OF TRAFFIC CONTROL DEVICES FOR CONSTRUCTION ON RURAL LOCAL HIGHWAYS
B.L.R. 22-6	TYPICAL APPLICATION OF TRAFFIC CONTROL DEVICES FOR CONSTRUCTION ON RURAL LOCAL HIGHWAYS (TWO-LANE TWO-WAY RURAL TRAFFIC) (ROAD CLOSED TO THRU TRAFFIC)

SUMMARY OF QUANTITIES

CODE NO.	ITEM	UNIT	QUANTITY
20200100	EARTH EXCAVATION	CU YD	1029.00
20300100	CHANNEL EXCAVATION	CU YD	226.00
20400800	FURNISHED EXCAVATION	CU YD	48.00
28000305	TEMPORARY DITCH CHECKS	FOOT	7.00
28001000	AGGREGATE (EROSION CONTROL)	TON	9.00
28100807	STONE DUMPED RIPRAP, CLASS A4	TON	506.00
28200200	FILTER FABRIC	SQ YD	300.00
40200800	AGGREGATE SURFACE COURSE, TYPE B	TON	300.00
50100100	REMOVAL OF EXISTING STRUCTURES	EACH	1.00
50300225	CONCRETE STRUCTURES	CU YD	22.20
50300280	CONCRETE ENCASEMENT	CU YD	2.80
50400405	PRECAST PRESTRESSED CONCRETE DECK BEAMS (21" DEPTH)	SO FT	1320.00
50800105	REINFORCEMENT BARS	POUND	2430.00
Δ 50900205	STEEL RAILING, TYPE S1	FOOT	105.00
51201400	FURNISHING STEEL PILES 10X42	FOOT	520.00
51202305	DRIVING PILES	FOOT	520.00
51500100	NAME PLATES	EACH	1.00
* 67100100	MOBILIZATION	L SUM	1.00
X2501000	SEEDING, CLASS 2 (SPECIAL)	ACRE	0.50

Δ SPECIALTY ITEMS

DESIGN DESIGNATION:
 DESIGN SPEED: 30 MPH
 HIGHWAY CLASS - LOCAL ROAD
 EXISTING STRUCTURE NO.: 097-3095
 PROPOSED STRUCTURE NO.: 097-3266
 CURRENT A.D.T. = 80
 CONTRACT NO. 99430

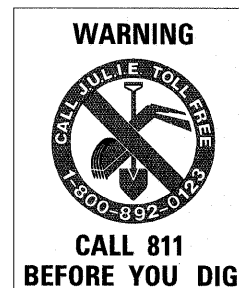

STATE OF ILLINOIS DEPARTMENT OF TRANSPORTATION DIVISION OF HIGHWAYS

PLANS FOR PROPOSED HIGHWAY BRIDGE PROGRAM

T.R. 235 WHITE COUNTY SECTION 08-04126-00-BR

PROJECT NO. BROS-193(043) JOB NO. C-99-520-09

CONTRACT # 99430 SEVEN MILE CREEK TRIBUTARY

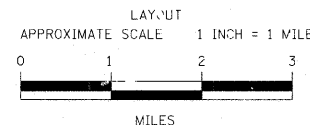
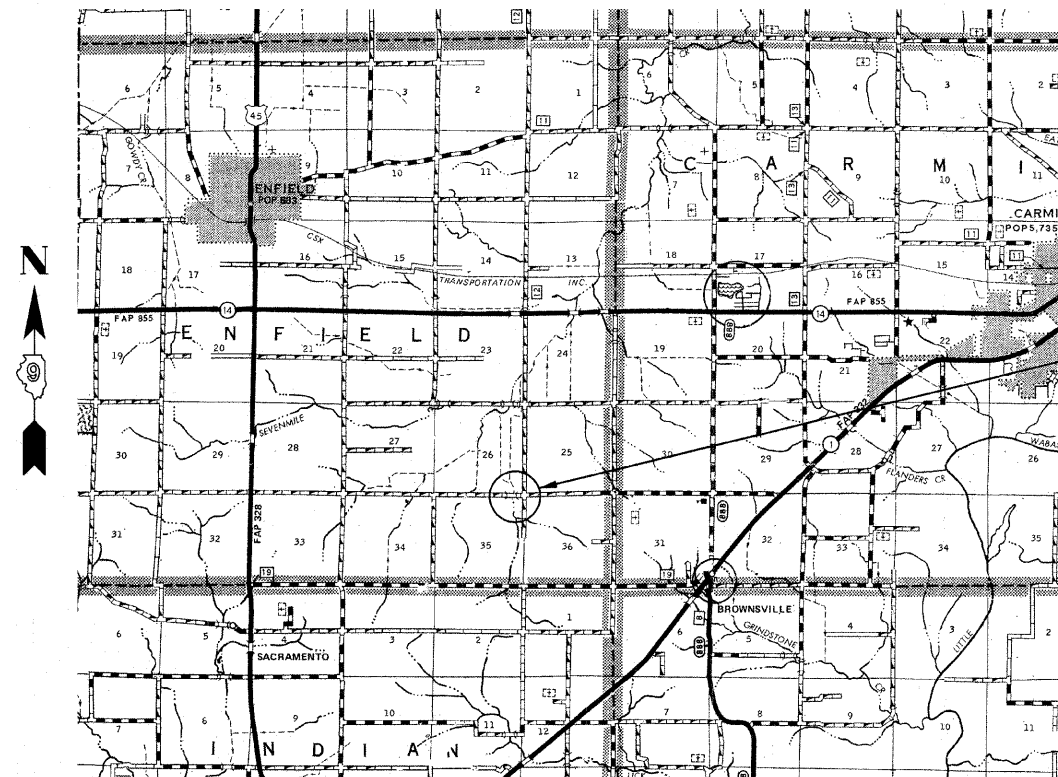

	FEET	MILES
GROSS LENGTH	500.00 FT	0.095 MILES
OMISSIONS	0.00 FT	0.000 MILES
NET LENGTH	500.00 FT	0.095 MILES

TR	SECTION	COUNTY	TOTAL SHEETS	SHEET NO.
235	08-04126-00-BR	WHITE	13	1

FED. ROAD DIST. NO. 9 ILLINOIS FED. AID PROJECT
 PROJECT # BROS-193(043) CONTRACT # 99430
 JOB # C-99-520-09 SEVEN MILE CREEK TRIBUTARY
 LEC JOB # H091004WH

323 W. 3RD ST.
 P.O. BOX 160
 MT. CARMEL, IL 62863
 PHONE: (618)-262-8651
 FAX: (618)-263-3327

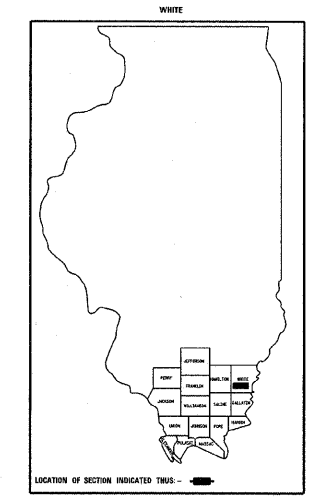

PROFESSIONAL DESIGN FIRM
 LAND SURVEY & PROFESSIONAL ENGINEERING CORPORATION
 184-00887
 (62-032435)(35-002769)

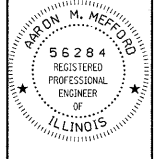

AARON M. MEFFORD
 NAME
 SIGNATURE
 DATE
 11-30-11 EXPIRES

PLAN	1" = 50'	0 50' 100'
PROFILE	1" = 50'	0 50' 100'
PROFILE VERT.	1" = 5'	0 5' 10'
CROSS SECTION	1" = 5'	0 5' 10'

SECTION 08-04126-00-BR
 BEGINS STATION 2+50

STATION 5+00, STRUCTURE NO. 097-3266
 A 55' LONG SINGLE SPAN PRECAST PRESTRESSED CONCRETE DECK BEAM (21" DEPTH), 24' ROADWAY, 0.00% GRADE, 0° SKEW.

SECTION 08-04126-00-BR
 ENDS STATION 7+50

STATE OF ILLINOIS
 DEPARTMENT OF TRANSPORTATION

APPROVED 10/28/10
Brian A. Ray
 COUNTY ENGINEER

PASSED 12/7/2010
Dennis W. Hill
 ENGINEER OF LOCAL ROADS AND STREETS

RELEASING FOR BID
 BASED ON LIMITED REVIEW: 12/7/10
Mary C. Lamie
 MARY C. LAMIE, P.E.
 DEPUTY DIRECTOR OF HIGHWAYS
 REGION FIVE ENGINEER

T.R. 235
 OVER CREEK
 WHITE COUNTY, ILLINOIS

SHEET TITLE:
 TITLE SHEET

SCALE: VARIES

BY: AMM
 DATE: 10/28/10
 REV:

1 OF 13
 SHEETS
 SHEET NO.
 1

GENERAL NOTES:

THIS SECTION SHALL BE CONSTRUCTED IN ACCORDANCE WITH THE PLANS, SPECIAL PROVISIONS AND "STANDARD SPECIFICATIONS FOR ROAD AND BRIDGE CONSTRUCTION", ADOPTED JANUARY 1, 2007.

THE WORK INVOLVED ON THIS SECTION CONSISTS OF THE REMOVAL OF THE EXISTING STRUCTURE, THE CONSTRUCTION OF A 55' FOOT LONG SINGLE SPAN PRECAST, PRESTRESSED CONCRETE DECK BEAM BRIDGE, EARTH APPROACHES, AGGREGATE SURFACE COURSE AND OTHER MISCELLANEOUS ITEMS NECESSARY TO COMPLETE THIS SECTION.

ALL ELEVATIONS ARE BASED ON U.S.G.S. MEAN SEA LEVEL DATUM.

IT SHALL BE THE CONTRACTOR'S RESPONSIBILITY TO CONTACT ALL THE UTILITIES, AFFECTING THE PROJECT, PRIOR TO CONSTRUCTION.

THE EXISTING DECK BEAM SHALL BE SALVAGED AND DELIVERED TO THE ENFIELD TOWNSHIP YARD. THIS WORK SHALL BE CONSIDERED AS REMOVAL OF EXISTING STRUCTURES.

THE QUANTITY OF S-HOWN IN THE SUMMARY OF QUANTITIES FOR STONE DUMPED RIPRAP, CLASS A4 ALLOWS 186 TONS FOR THE STONE RIPRAP DITCH AND 320 TON FOR THE BRIDGE.

NOTE: CONSTRUCTION TRANSITION
STA. 2+50 TO STA 3+00
STA 7+00 TO STA 7+50
ALL QUANTITIES ARE INCLUDED IN THE PROPOSAL

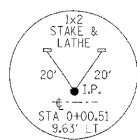

CURVE #1
P.I. STA= 2+79.78
Δ RT, 0°45'40"
D= 0°42'58"
R= 8000'
T= 53.13'
L= 106.26'
e= 0.19'
e= NONE
T.R.= NONE
S.E. RUN= NONE
P.C. STA= 2+26.65
P.T. STA= 3+32.91

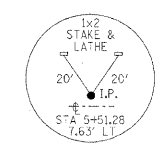

CURVE #2
P.I. STA= 8+27.84
Δ LT, 1°37'41"
D= 1°08'45"
R= 5000'
T= 71.04'
L= 142.08'
e= 0.50'
e= NONE
T.R.= NONE
S.E. RUN= NONE
P.C. STA= 7+56.79
P.T. STA= 8+98.87

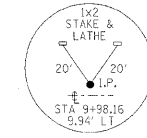

TYPICAL CROSS SECTION PROPOSED

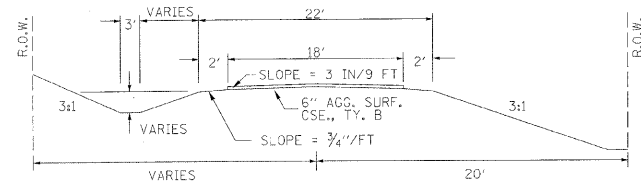

TYPICAL CROSS SECTION EXISTING

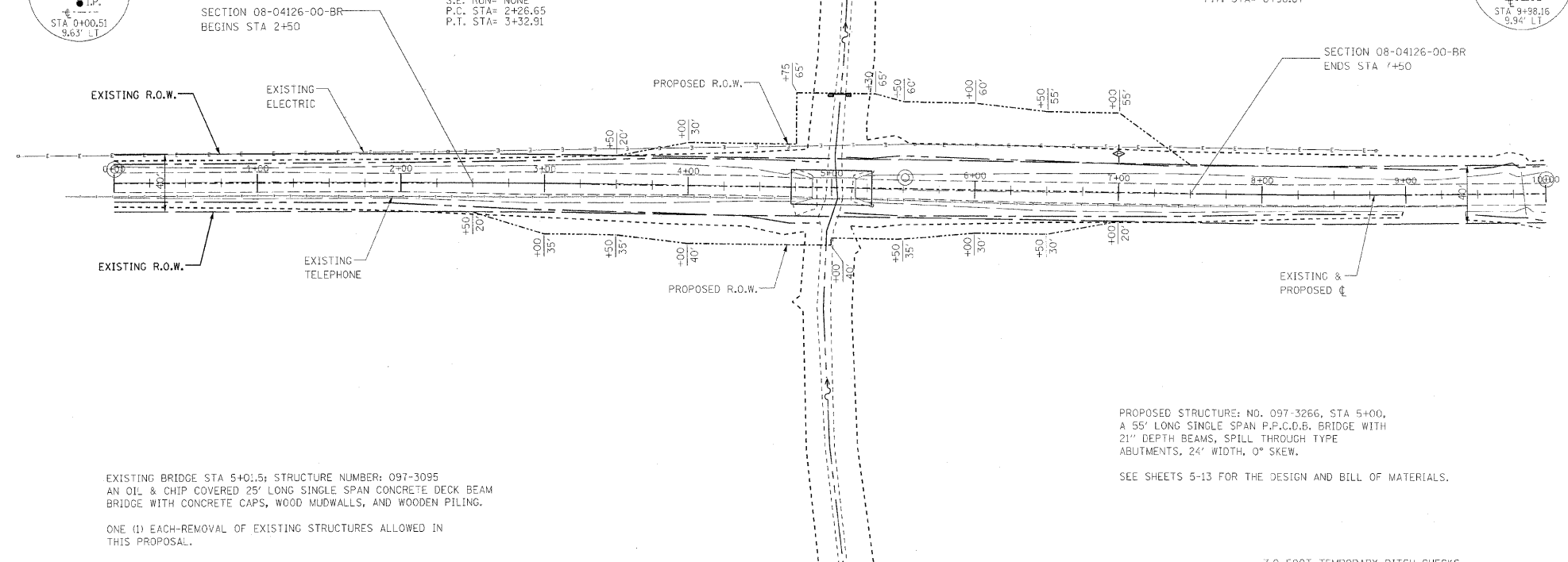
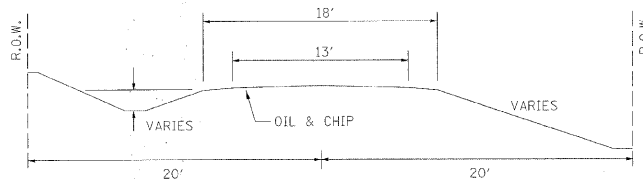

EXISTING BRIDGE STA 5+01.5; STRUCTURE NUMBER: 097-3095
AN OIL & CHIP COVERED 25' LONG SINGLE SPAN CONCRETE DECK BEAM BRIDGE WITH CONCRETE CAPS, WOOD MUDWALLS, AND WOODEN PILING.

ONE (1) EACH-REMOVAL OF EXISTING STRUCTURES ALLOWED IN THIS PROPOSAL.

PROPOSED STRUCTURE: NO. 097-3266, STA 5+00, A 55' LONG SINGLE SPAN P.P.C.D.B. BRIDGE WITH 21" DEPTH BEAMS, SPILL THROUGH TYPE ABUTMENTS, 24' WIDTH, 0° SKEW.

SEE SHEETS 5-13 FOR THE DESIGN AND BILL OF MATERIALS.

UTILITIES:
U.L.L.I.E. 1-800-892-0123
VERIZON
1-618-997-0707
WAYNE-WHITE ELECTRIC CO-OP
1-618-842-2196

NOTE: CONSTRUCT SPECIAL DITCH

STA 2+50 TO STA 4+80 RT
STA 3+50 TO STA 4+76 LT
STA 5+24 TO STA 7+00 RT
STA 5+13 TO STA 7+50 LT

NOTE: CONSTRUCT STONE RIPRAP DITCH

STA 3+80 TO STA 4+80 RT (0.62 TON/LIN FT)
STA 4+26 TO STA 4+76 LT (0.62 TON/LIN FT)
STA 5+24 TO STA 5+74 RT (0.62 TON/LIN FT)
STA 5+13 TO STA 6+13 LT (0.62 TON/LIN FT)
286 TON STONE DUMPED RIPRAP, CLASS A4.

SEE STONE RIPRAP DITCH DESIGN.

STONE RIPRAP DITCH DESIGN

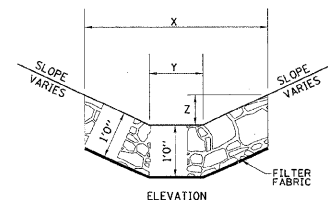
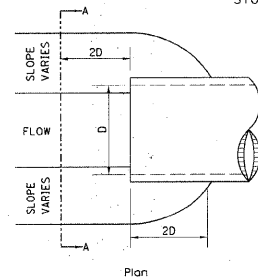

NOTE:

BOTTOM OF DITCH

SLOPE

	1 1/2:1	2:1	3:1
X=	5 FT	6 FT	8 FT
Y=	2 FT	2 FT	2 FT
Z=	1 FT	1 FT	1 FT
	0.40	0.48	0.62
	TON/LIN. FT		

NOTE: FILL NEXT TO BRIDGE TO BE AGGREGATE SURFACE COURSE

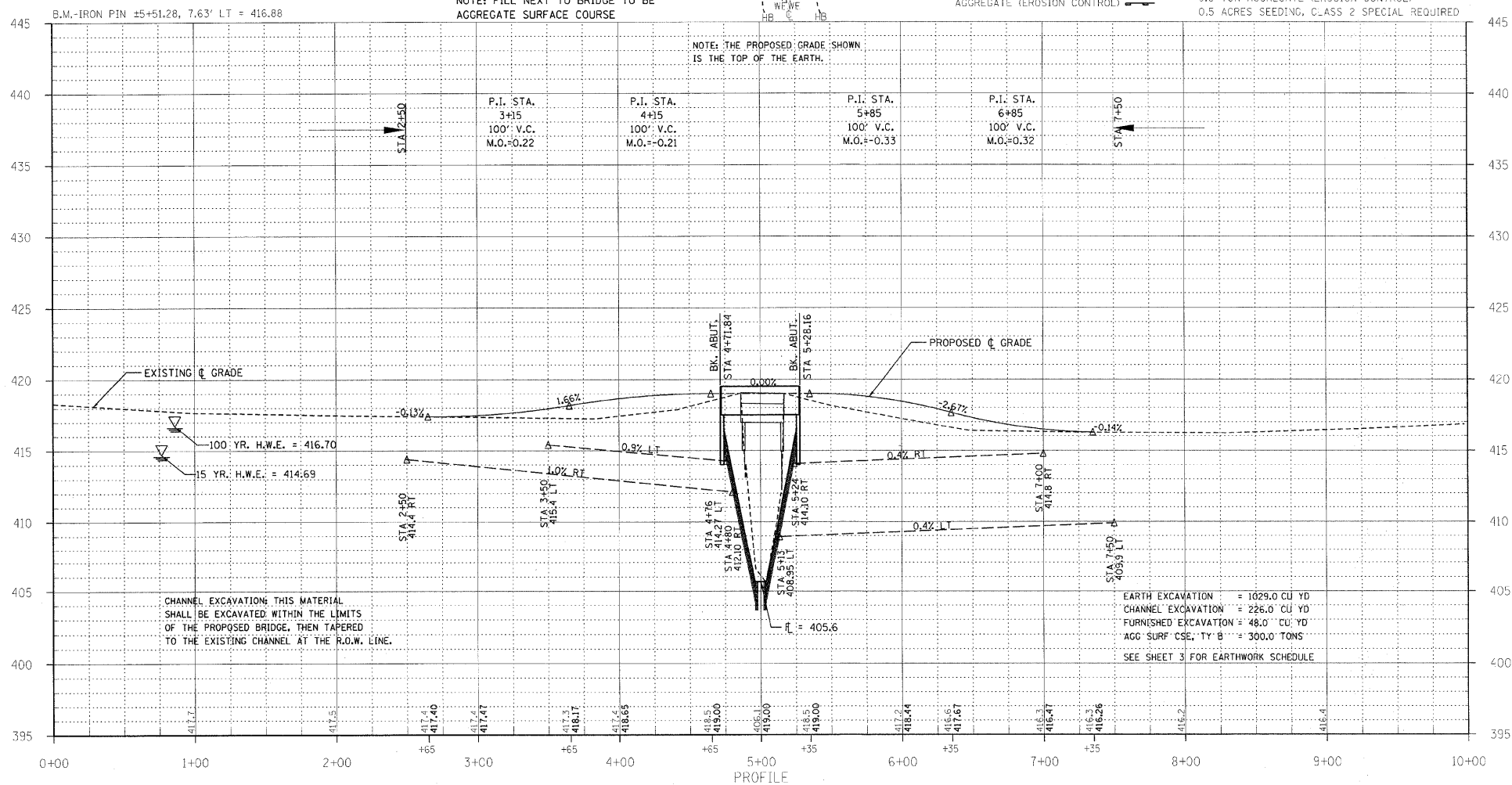

CHANNEL EXCAVATION: THIS MATERIAL SHALL BE EXCAVATED WITHIN THE LIMITS OF THE PROPOSED BRIDGE, THEN TAPERED TO THE EXISTING CHANNEL AT THE R.O.W. LINE.

TEMPORARY DITCH CHECKS
AGGREGATE (EROSION CONTROL)
7.0 FOOT TEMPORARY DITCH CHECKS
9.0 TON AGGREGATE (EROSION CONTROL)
0.5 ACRES SEEDING, CLASS 2 SPECIAL REQUIRED

EARTH EXCAVATION = 1029.0 CU YD
CHANNEL EXCAVATION = 226.0 CU YD
FURNISHED EXCAVATION = 48.0 CU YD
AGG SURF CSE, TY B = 300.0 TONS
SEE SHEET 3 FOR EARTHWORK SCHEDULE

TR	SECTION	COUNTY	TOTAL SHEETS	SHEET NO.
235	08-04126-00-BR	WHITE	13	2

PROJECT # 8805-1930433 CONTRACT # 99430
LEC JOB # H091004WH

323 W. 3RD ST.
P.O. BOX 160
MT. CARMEL, IL
62863
PHONE:
(618)-262-8651
FAX:
(618)-263-3327

405 W. STATE ST.
SUITE 1
PRINCETON, IN
47670
PHONE:
(812)-386-7611
FAX:
(812)-385-2812

PROFESSIONAL DESIGN FIRM
LAND SURVEY &
PROFESSIONAL ENGINEERING CORPORATION
184-000887
(62-032435)(35-002769)

AARON M. MEFFORD
NAME
SIGNATURE
10-28-10
DATE
11-30-11
EXPIRES

T.R. 235
OVER SEVEN MILE CREEK TRIB.
WHITE COUNTY, ILLINOIS

SHEET TITLE:
PLAN & PROFILE

SCALE:	VARIABLE
BY:	AMM
DATE:	10/27/10
REV:	

2 OF 13 SHEETS
SHEET NO. 2

TR	SECTION	COUNTY	TOTAL SHEETS	SHEET NO.	
235	08-04126-00-BR	WHITE	13	3	323 W 3RD ST. P.O. BOX 160 MT. CARMEL, IL 62863
FED. ROAD DIST. NO. 9 ILLINOIS		FED. AID PROJECT			PHONE: (618)-262-8651
PROJECT# BROS-19310431		CONTRACT# 99430			FAX: (618)-263-3327
JOB NO. C-99-520-09		SEVEN MILE CREEK TRIBUTARY			
LEC JOB # H09L004WH					

405 W STATE ST
SUITE 1
PRINCETON, IN
47670
PHONE:
(812)-386-7611
FAX:
(812)-385-2812



PROFESSIONAL
DESIGN FIRM
LAND SURVEY &
PROFESSIONAL
ENGINEERING
CORPORATION
184-00087
(62-032435)(35-002789)

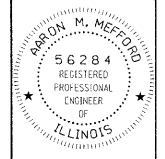

AARON M. MEFFORD
NAME
Aaron Mefford
SIGNATURE
10-28-10
DATE
11-30-11
EXPIRES

TR 235
OVER SEVEN MILE CREEK TRIB.
WHITE COUNTY, ILLINOIS

SHEET TITLE:
CROSS-SECTIONS
SCALE: 1" = 5'
BY: AMM
DATE: 10/28/10
REV:
3 OF 13
SHEETS
SHEET NO.
3

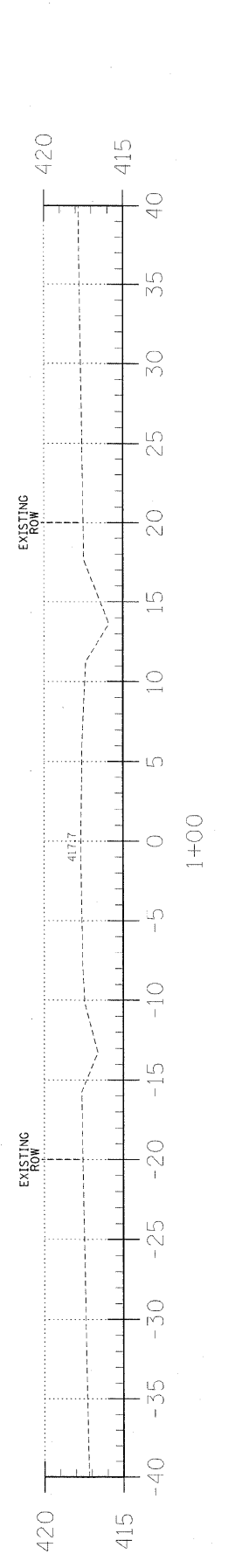
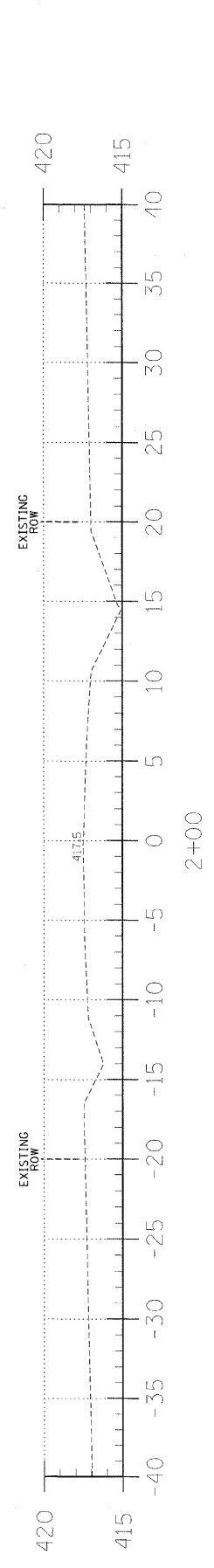
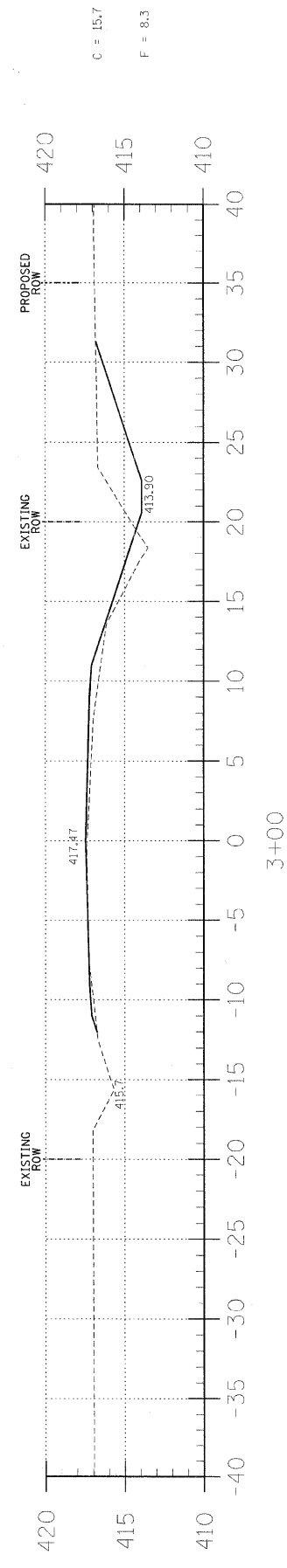
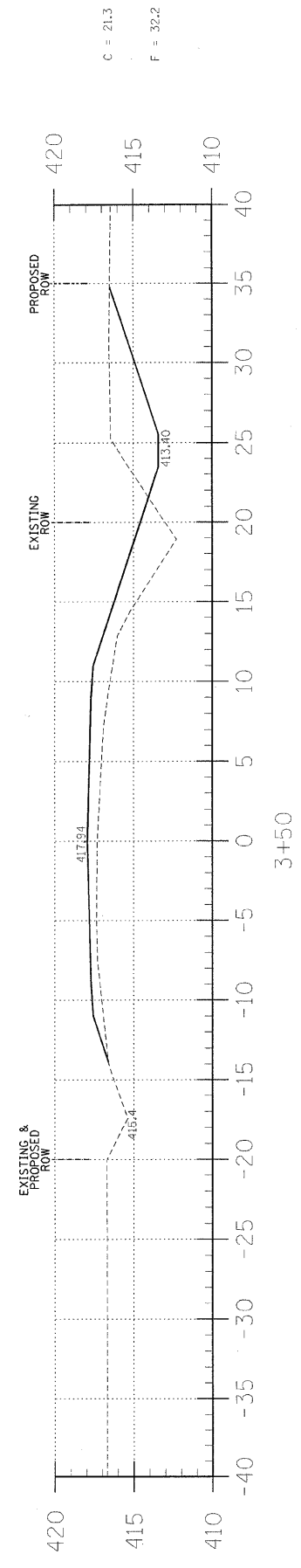
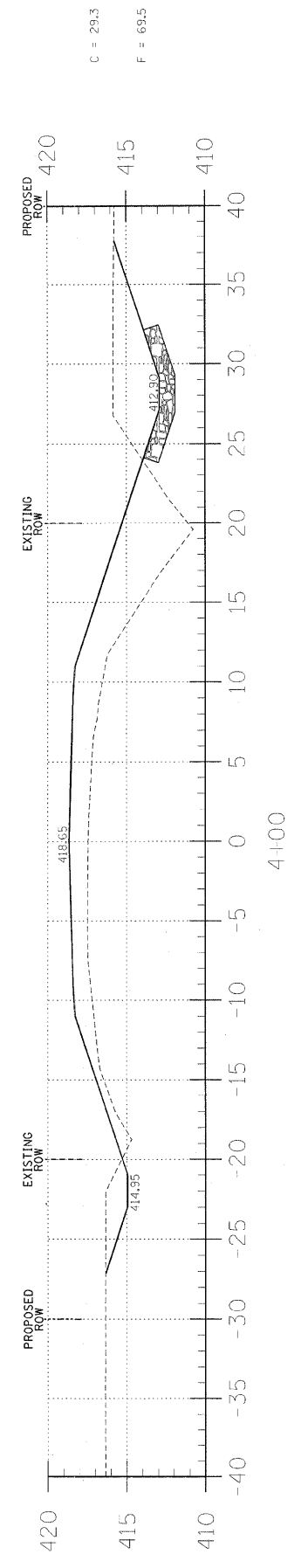
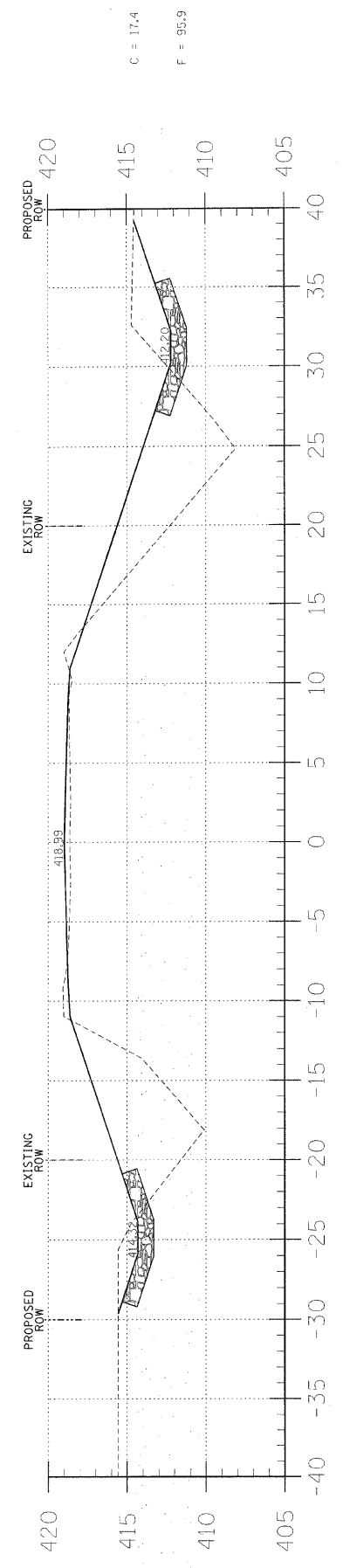

EARTHWORK SCHEDULE

LOCATION	EARTH EXCAVATION	CHANNEL EXCAVATION	ESTIMATED UNSUITABLE MATERIAL	SUITABLE MATERIAL ADJUSTED FOR SHRINKAGE	EMBANKMENT	EARTHWORK BALANCE WASTE (+) OR SHORTAGE (-)
	CUBIC YARD	CUBIC YARD	CUBIC YARD	CUBIC YARD	CUBIC YARD	CUBIC YARD
STA 0+00 TO 4+71.8	157.1	0.0	0.0	117.8	363.5	-245.7
STA 4+71.8 TO 5+28.2	0.0	226.5	113.3	84.9	0.0	84.9
STA 5+28.2 TO 10+00	872.2	0.0	0.0	654.2	540.9	113.3
TOTAL	1029.3	226.5	113.3	856.9	904.4	-47.5

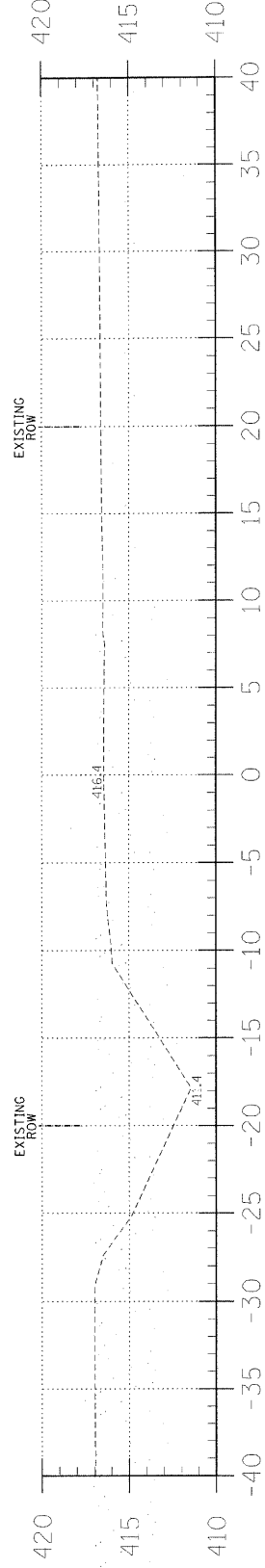

9+00

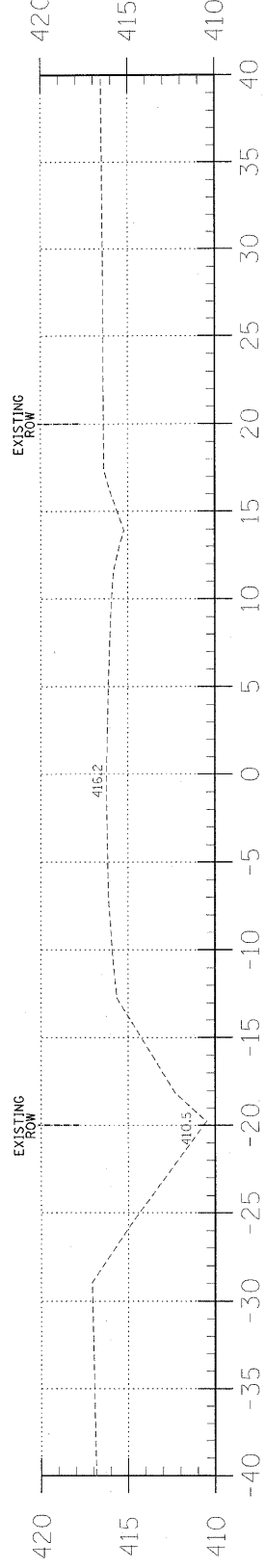

8+00

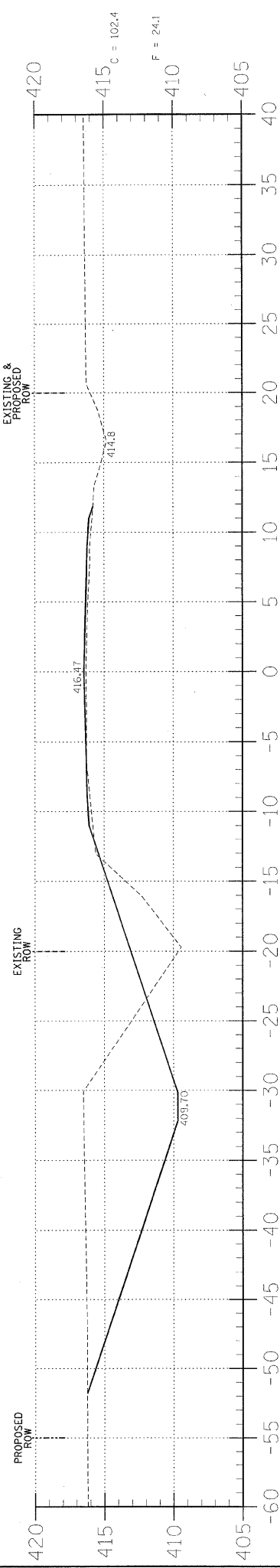

7+00

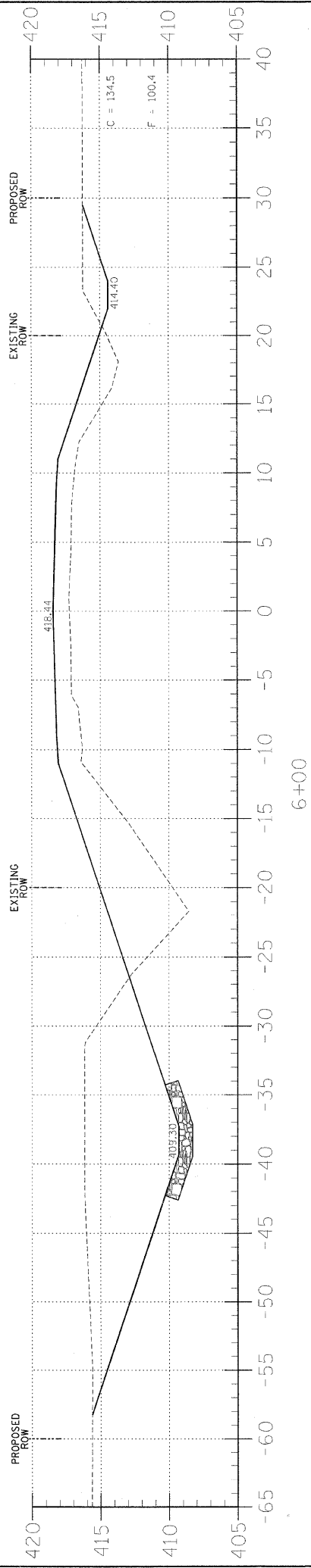

6+00

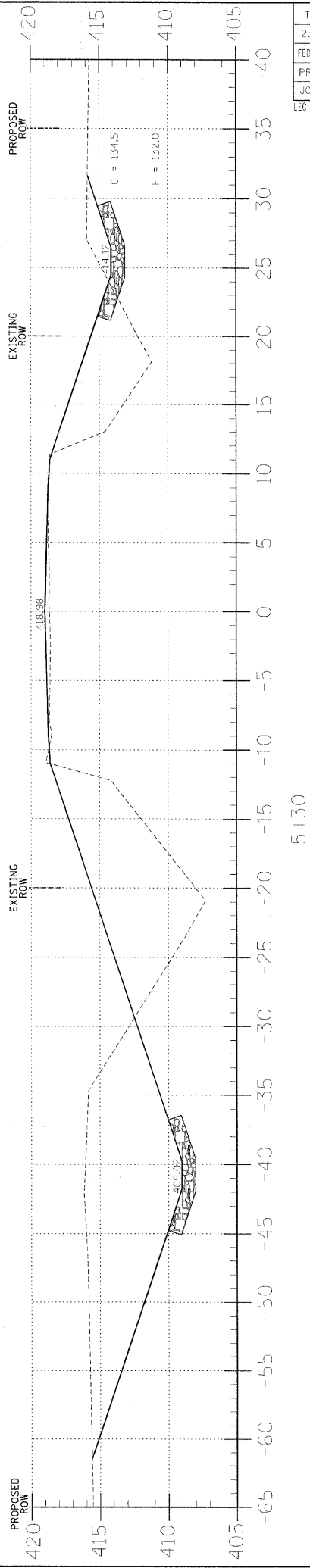

5+30

TR	SECTION	COUNTY	TOTAL SHEETS	SHEET NO.
235	08-04126-00-BR	WHITE	13	4
FED. ROAD DIST. NO. 9 ILLINOIS		FED. AID PROJECT		
PROJECT* BROS-1930(43)		CONTRACT* 99430		
JOB NO. C-99-520-09		SEVEN MILE CREEK TRIBUTARY		
LEC JOB # H091004WH				

323 W. 3RD ST.
P.O. BOX 160
MT. CARMEL, IL
62863
PHONE:
(618)-262-8651
FAX:
(618)-263-3327

405 W. STATE ST
SUITE 1
PRINCETON, IN
47670
PHONE:
(812)-386-7611
FAX:
(812)-385-2612



PROFESSIONAL
DESIGN FIRM
LAND SURVEY &
PROFESSIONAL
ENGINEERING
CORPORATION
184-001887
(62-032435)(35-002769)

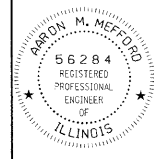

AARON M. MEFFORD
NAME
Aaron Mefford
SIGNATURE
10-28-10
DATE
11-30-11
EXPIRES

TR 235
OVER SEVEN MILE CREEK TRIB.
WHITE COUNTY, ILLINOIS

SHEET TITLE:

CROSS-SECTIONS

SCALE: 1" = 8'
BY: AMM
DATE: 10/28/10
REV:

4 OF 13
SHEETS

SHEET NO.
4

BENCHMARK: Iron Pin at Sta. 5+51.28, 7.63' Lt., Elev. 416.88

EXISTING STRUCTURE NO. 097-3095: 25' long single span concrete deck beam bridge with concrete caps, wood mudwalls and timber piling. Structure closed to traffic.

GENERAL NOTES

Layout of the slope protection system may be varied to suit ground conditions in the field as directed by the Engineer.
 Reinforcement bars shall conform to the requirements of ASTM A 706 Gr 60. See Special Provisions.
 Excavation required to construct the Abutments shall be included in the cost of Concrete Structures. No additional compensation will be allowed for Structure Excavation.
 All proposed construction activities shall be in accordance with Nationwide Permit number 14 of the Department of the Army authorized under Section 404 of the Clean Water Act. The IEPA has issued Section 401 Water Quality Certification for this activity. See Special Provisions for conditions.

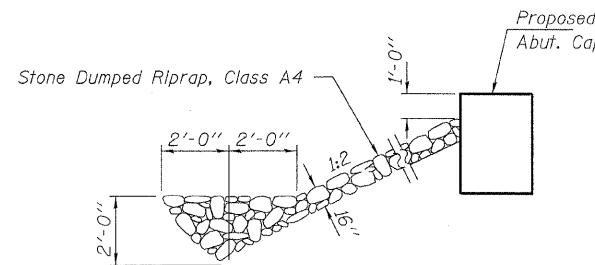
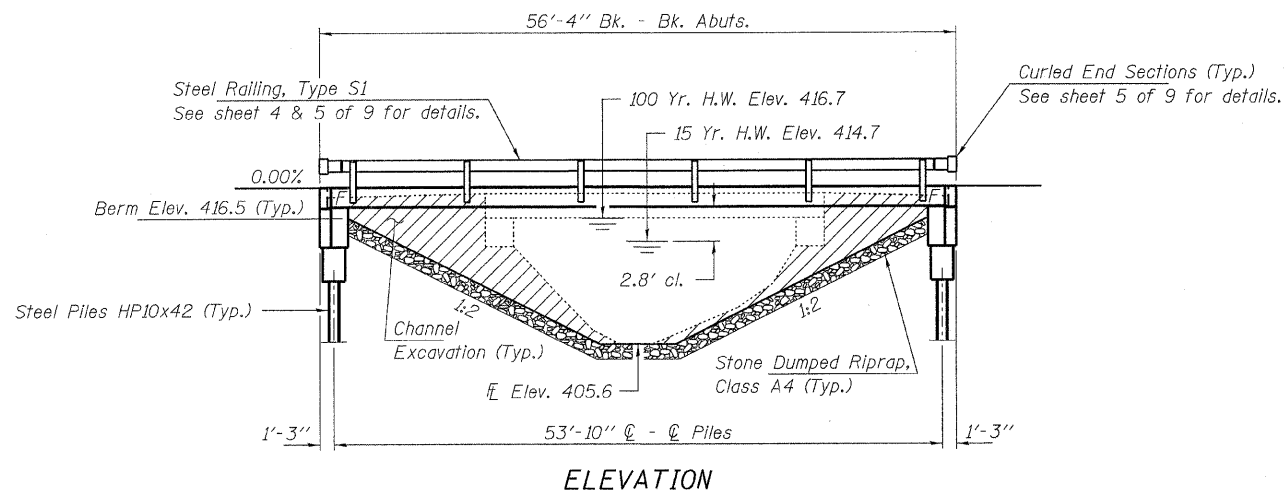

SECTION A-A

Note: See Special Provisions for Stone Dumped Riprap, Class A4.

INDEX OF STRUCTURE SHEETS

1. General Plan & Elevation
2. Superstructure
- 3.-4. Superstructure Details
5. Steel Railing, Type S-1
6. Abutments
7. HP Pile Details
- 8.-9. Borings

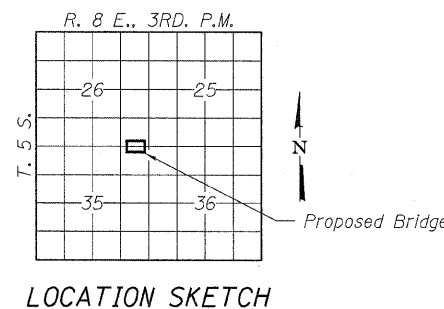
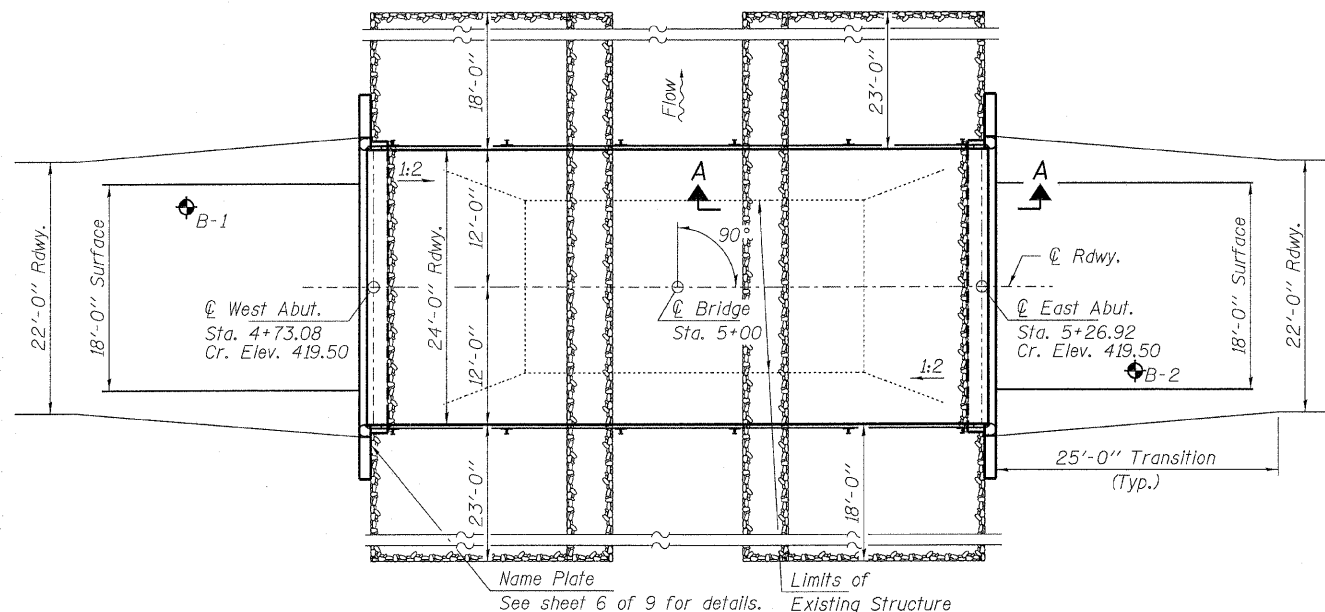

BUILT 20__ BY
 WHITE COUNTY
 SEC. 08-04126-00-BR
 ENFIELD ROAD DISTRICT
 STR. NO. 097-3266
 LOADING HL-93

NAME PLATE
 See Std. 515001

TOTAL BILL OF MATERIAL

ITEM	UNIT	SUPER	SUB	TOTAL
Channel Excavation	Cu. Yd.			226
Stone Dumped Riprap, Class A4	Ton			320
Removal of Existing Structures	Each			1
Concrete Structures	Cu. Yd.		22.2	22.2
Concrete Encasement	Cu. Yd.		2.8	2.8
Precast Prestressed Concrete Deck Beams (21" Depth)	Sq. Ft.	1,320		1,320
Reinforcement Bars	Pound		2,430	2,430
Steel Railing, Type S1	Foot	105		105
Furnishing Steel Piles HP10x42	Foot		520	520
Driving Piles	Foot		520	520
Name Plates	Each		1	1

DESIGN STRESSES

FIELD UNITS

f'c = 3,500 psi
 fy = 60,000 psi (Reinf.)

PRECAST PRESTRESSED UNITS

f'c = 6,000 psi
 f'ci = 5,000 psi
 fpu = 270,000 psi (1/2" low lax. strands)
 fpbt = 201,960 psi (1/2" low lax. strands)
 fy = 60,000 psi (Reinf.)

LOADING HL-93

Design Specifications: 2007 AASHTO LRFD with all applicable Interims.
 50#/Sq. Ft. included in dead load for future wearing surface.

SEISMIC DATA

Seismic Performance Zone (SPZ) = 3
 Design Spectral Acceleration at 1.0 sec. (SD1) = 0.459g
 Design Spectral Acceleration at 0.2 sec. (SDS) = 0.866g
 Soil Site Class = E

WATERWAY INFORMATION

Flood	Freq. Yr.	Q C.F.S.	Opening Sq. Ft.		Head - Ft.		Headwater El.		
			Exist.	Prop.	H.W.E. Exist.	Prop.	Exist.	Prop.	
Design	15	1111	160	235	414.7	0.1	0.1	414.8	414.8
Base	100	1960	212	332	416.7	1.1	0.2	417.8	416.9
Max. Calc.	500								

I certify that to the best of my knowledge, information and belief, this bridge design is structurally adequate for the design loading shown on the plans. The design is an economical one for the style of structure and complies with requirements of the current "AASHTO LRFD Specifications."

Steven W. Megginson 10/12/2010
 ILLINOIS STRUCTURAL NO. 081-6084 Expires 11-30-2012

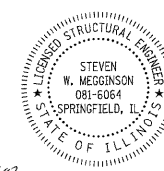

FILE NAME = 090858-shr-bridge.dgn	USER NAME =	DESIGNED - A.S.L.	REVISED - 01/18/10
HAMPTON, LENZINI AND RENWICK, INC. 3083 STEVENSON DRIVE, SUITE 201 SPRINGFIELD, ILLINOIS 62793 ILLINOIS PROFESSIONAL DESIGN FIRM L/S / P/E / SE CORP. 184-000959	PLOT SCALE =	CHECKED - S.W.M.	REVISED -
PLOT DATE = 10/12/2010		DRAWN - D.T.M.	REVISED -
		CHECKED - S.W.M.	REVISED -

STATE OF ILLINOIS
 WHITE COUNTY HIGHWAY DEPARTMENT

GENERAL PLAN & ELEVATION
 STRUCTURE NO. 097-3266

SHEET NO. 1 OF 9 SHEETS

T.R.	SECTION	COUNTY	TOTAL SHEETS	SHEET NO.
235	08-04126-00-BR	WHITE	13	5
ENFIELD ROAD DISTRICT			CONTRACT NO. 99430	
ILLINOIS FED. AID PROJECT				

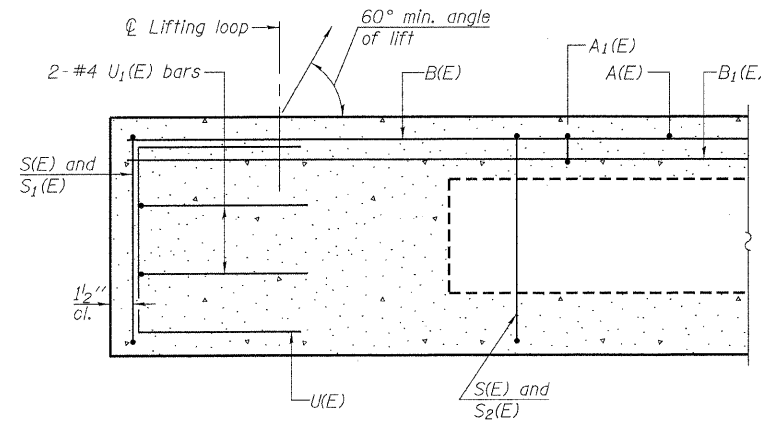

SECTION A-A

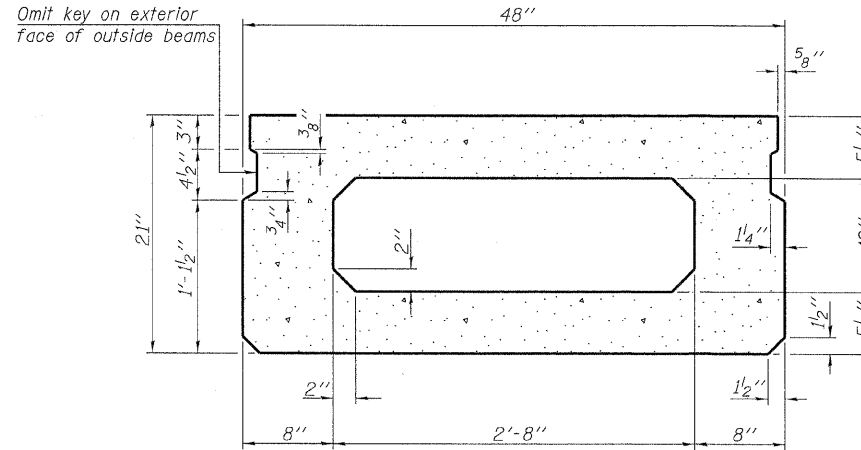

SECTION B-B
(Showing dimensions)

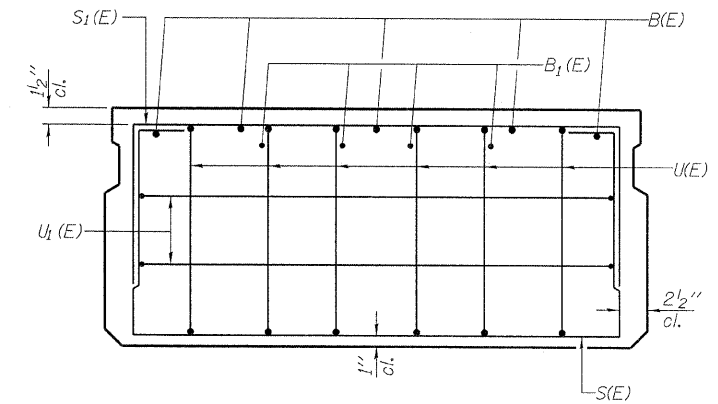

VIEW C-C

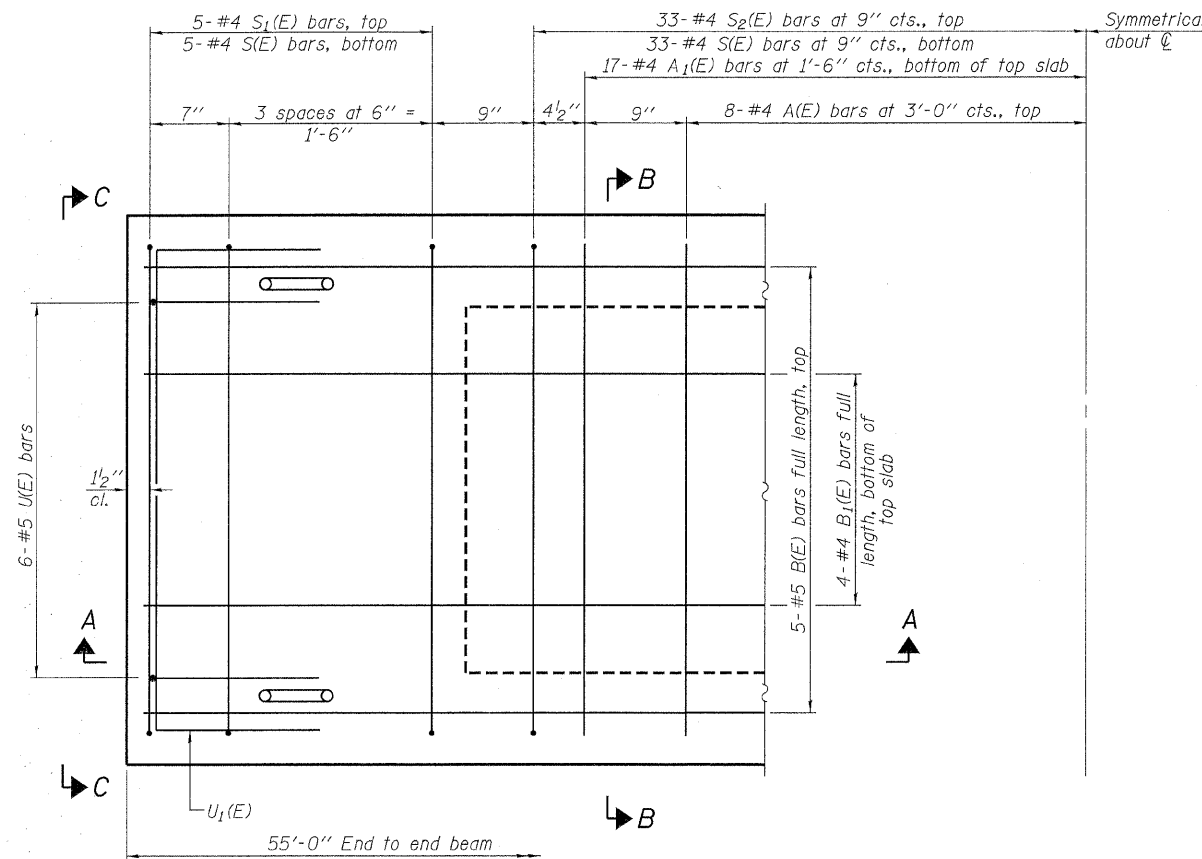

PLAN VIEW

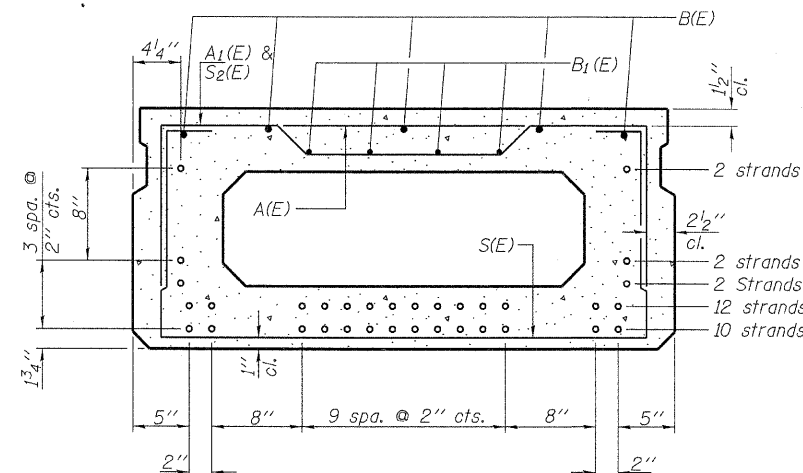

SECTION B-B
(Showing reinforcement and permissible strand locations)

Note: Place the number of strands specified in each row symmetrically about the centerline of beam in the permissible strand locations shown.

BAR LIST
ONE BEAM ONLY
(For Information Only)

Bar	No.	Size	Length	Shape
A(E)	16	#4	3'-7"	—
A1(E)	34	#4	3'-10"	—
B(E)	5	#5	54'-8"	—
B1(E)	4	#4	54'-8"	—
S(E)	76	#4	7'-5"	□
S1(E)	10	#4	5'-11"	□
S2(E)	66	#4	6'-2"	□
U(E)	12	#5	4'-0"	□
U1(E)	4	#4	6'-0"	□

Note: See sheets 3 & 4 of 8 for additional details and Bill of Material.

Note:
Spacing of S(E) and S2(E) bars may be adjusted up to 4" in the immediate area of the transverse tie diaphragms to miss the block outs for the transverse ties.

MINIMUM BAR LAP
#4 bar = 2'-0"
#5 bar = 2'-6"

PD-2148-0

7-1-10

FILE NAME = 090258-shr-brs.dgn	USER NAME =	DESIGNED - A.S.L.	REVISED - 01/18/10
HAMPTON, LENZINI AND RENWICK, INC. 3055 STEVENSON DRIVE, SUITE 201 SPRINGFIELD, ILLINOIS 62703	PLOT SCALE =	CHECKED - S.W.M.	REVISED -
ILLINOIS PROFESSIONAL DESIGN FIRM L.P./P.E./S.E. CORP. 184/000959	PLOT DATE = 10/12/2010	DRAWN - D.T.M.	REVISED -
		CHECKED - S.W.M.	REVISED -

STATE OF ILLINOIS
WHITE COUNTY HIGHWAY DEPARTMENT

21" x 48" PPC DECK BEAM
STRUCTURE NO. 097-3266

SHEET NO. 2 OF 9 SHEETS

T.R.	SECTION	COUNTY	TOTAL SHEETS	SHEET NO.
235	08-04126-00-BR	WHITE	13	6
ENFIELD ROAD DISTRICT			CONTRACT NO. 99430	
ILLINOIS FED. AID PROJECT				

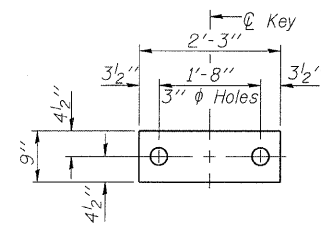

FABRIC BEARING PAD
(Interior - 10 Req'd.)

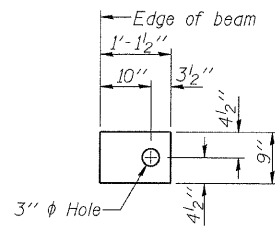

FABRIC BEARING PAD
(Exterior - 4 Req'd.)

FIXED

Notes:
All bearing pads shall be 1" thick.
Omit holes when using expansion bearings.
Expansion bearing pad shall be bonded to the substructure.

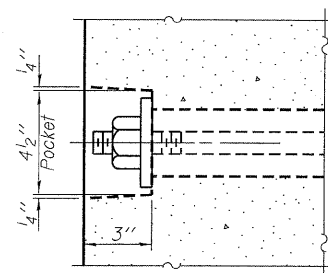

SECTION A-A

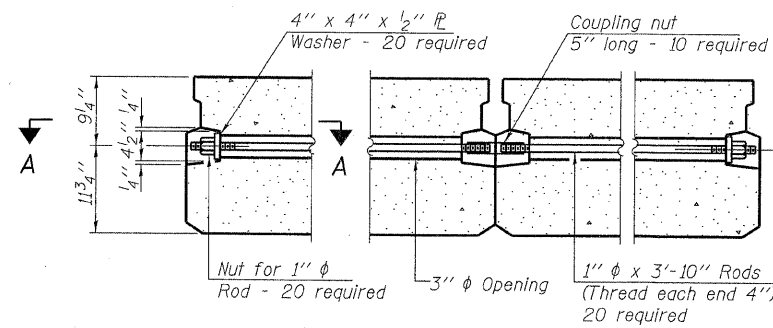

TYPICAL TRANSVERSE TIE ASSEMBLY

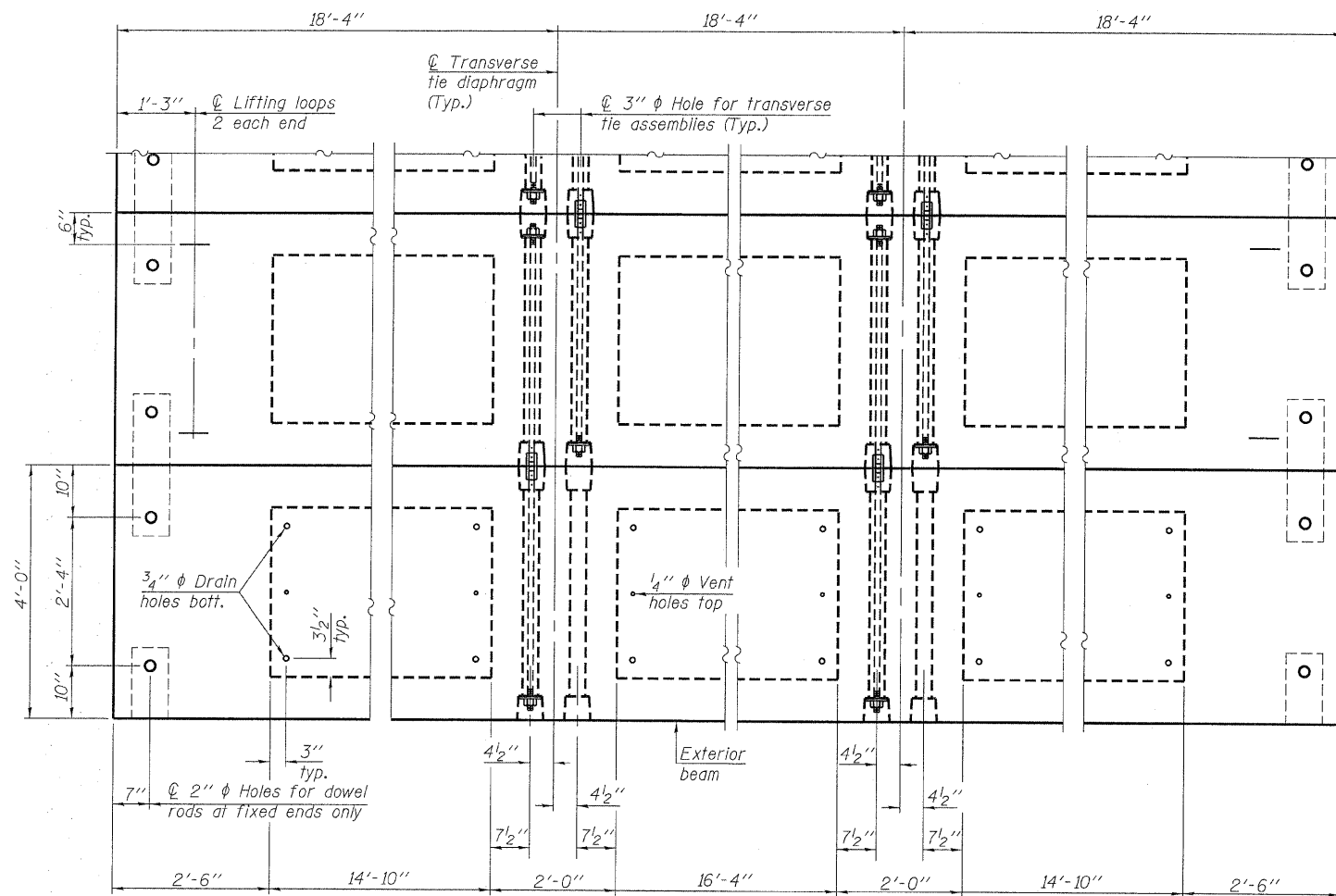

PLAN VIEW

Note: Connect beams in pairs with the transverse tie configuration shown.

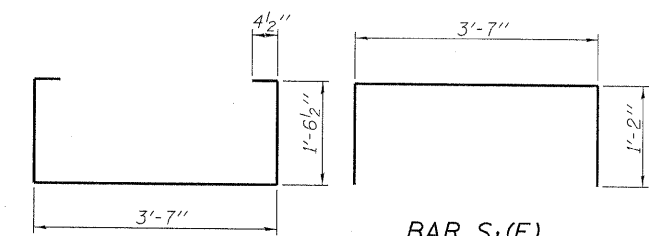

BAR S₁(E)

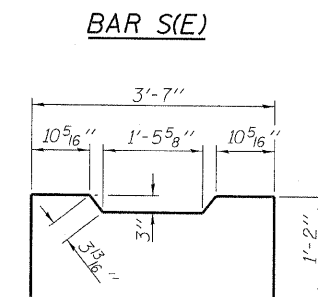

BAR S(E)

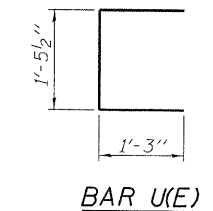

BAR U(E)

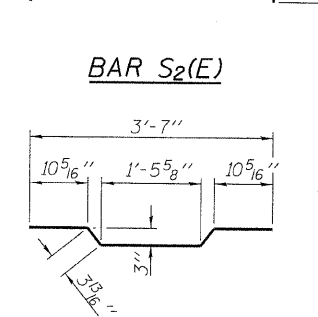

BAR S₂(E)

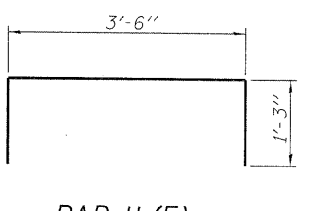

BAR U₁(E)

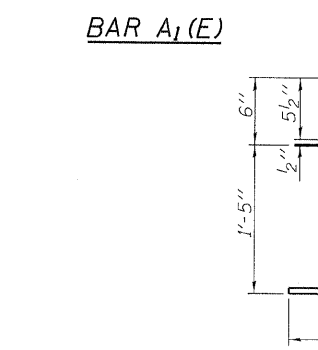

BAR A₁(E)

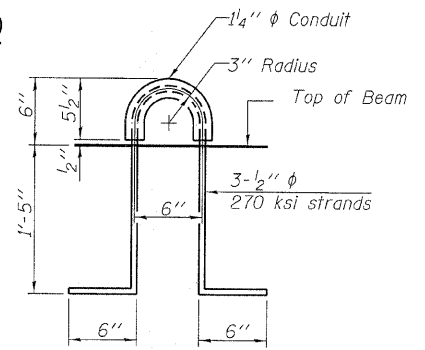

LIFTING LOOP DETAIL

NOTES

Prestressing steel shall be uncoated high strength, low relaxation 7-wire strand, Grade 270. The nominal diameter shall be 1/2" and the nominal cross-sectional area shall be 0.153 sq. in.
The 1" rods in the transverse tie assembly shall be tightened to a snug fit and the threads set. Pockets on exterior faces of bridge shall be filled with grout after transverse tie assembly is in place.
Reinforcement bars shall conform to ASTM A 706, Grade 60. (See Special Provisions).
Two 1/8" fabric adjusting shims of the dimensions of the exterior bearing pad shall be provided for each bearing pad location.
A minimum 2 1/2" diameter lifting pin shall be used to engage the lifting loops during handling.
Corrosion Inhibitor, per Article 1020.05(b)(12) and 1021.06 of the Standard Specifications, shall be used in the concrete for precast prestressed concrete deck beams.
Compressive strength of prestressed concrete, f'c, shall be 6000 psi.
Compressive strength of prestressed concrete at release, f'cl, shall be 5000 psi.
All reinforcement shall be epoxy coated.

BILL OF MATERIAL

Precast Prestressed Conc. Deck Bms. (21" depth)	Sq. Ft.	1,320
---	---------	-------

PD-2148-OD 7-1-10

FILE NAME = 090058-sht-br.dgn	USER NAME =	DESIGNED - A.S.L.	REVISED - 01/18/10
HAMPTON, LENZINI AND RENWICK, INC.		CHECKED - S.W.M.	REVISED -
3035 STEVENSON DRIVE, SUITE 201 SPRINGFIELD, ILLINOIS 62703	PLOT SCALE =	DRAWN - D.T.M.	REVISED -
ILLINOIS PROFESSIONAL DESIGN FIRM LS / PE / SE CORP. 184-00959	PLOT DATE = 10/12/2010	CHECKED - S.W.M.	REVISED -

**STATE OF ILLINOIS
WHITE COUNTY HIGHWAY DEPARTMENT**

**21" x 48" PPC DECK BEAM
STRUCTURE NO. 097-3266**

SHEET NO. 3 OF 9 SHEETS

T.R.	SECTION	COUNTY	TOTAL SHEETS	SHEET NO.
235	08-04126-00-BR	WHITE	13	7
ENFIELD ROAD DISTRICT			CONTRACT NO. 99430	
ILLINOIS FED. AID PROJECT				

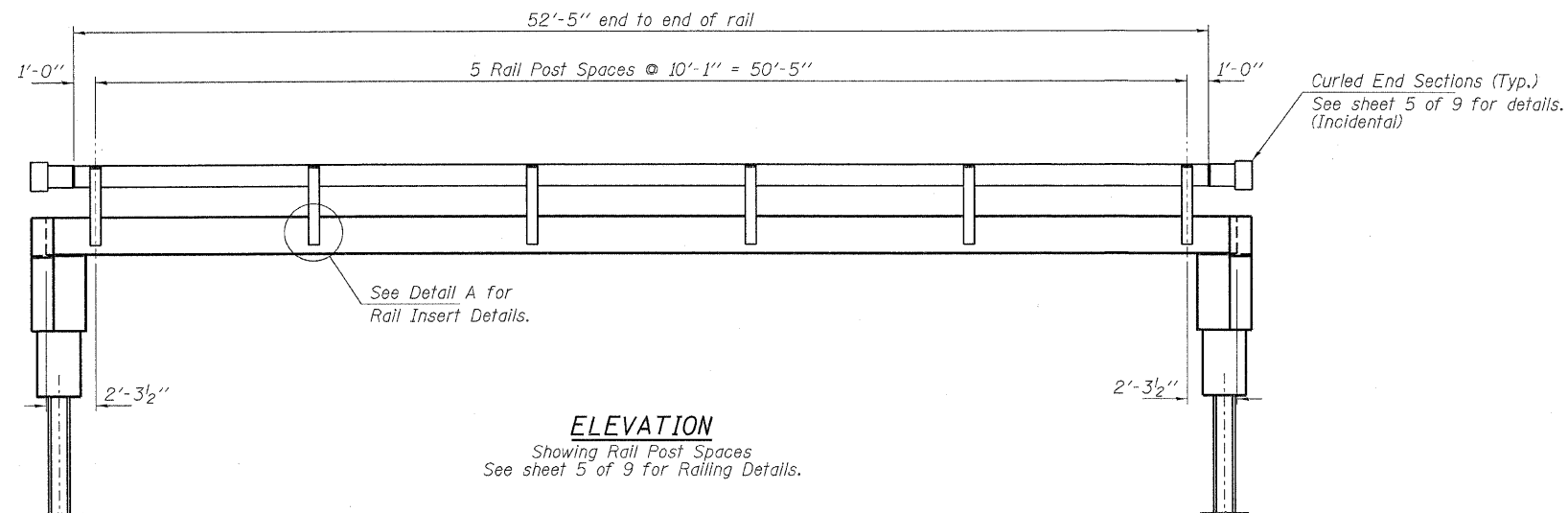

ELEVATION
Showing Rail Post Spacing
See sheet 5 of 9 for Railing Details.

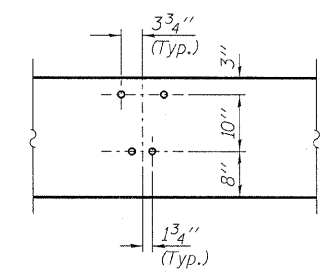

DETAIL A

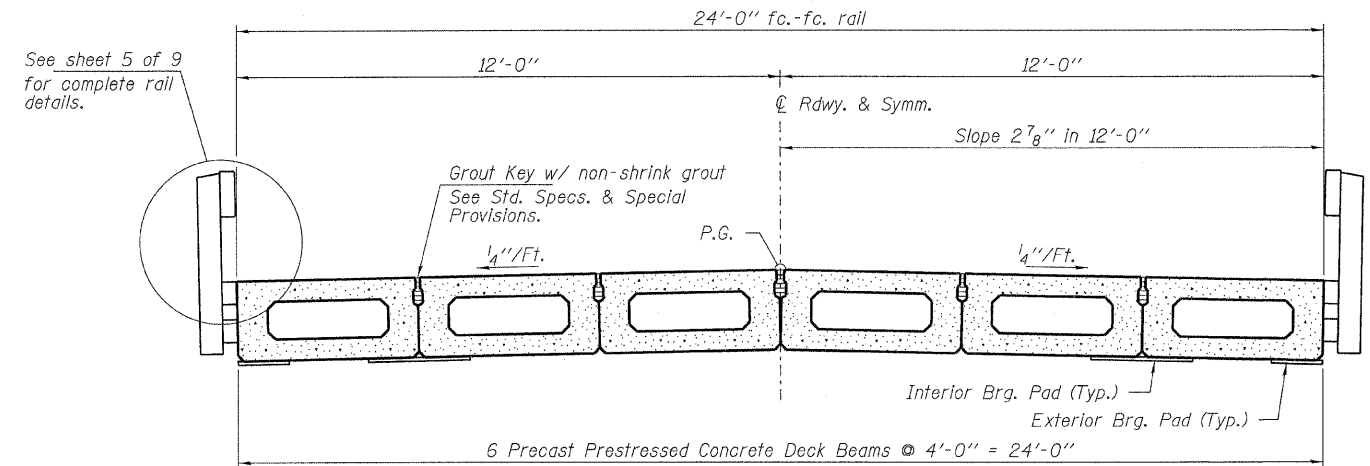

CROSS SECTION
See sheets 2 & 3 of 9 for Superstructure.

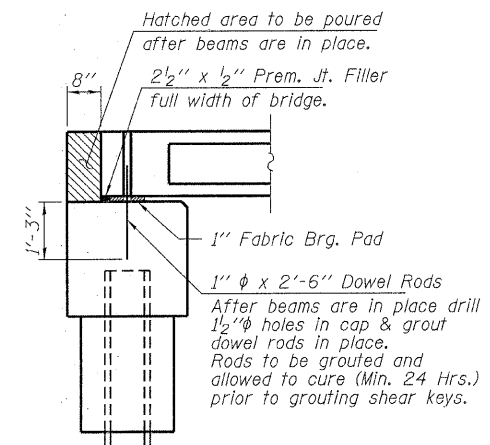

SECTION AT ABUTMENTS
© Rt. L's

FILE NAME = 098058-shb-bridge.dgn	USER NAME =	DESIGNED - A.S.L.	REVISED - 01/18/10	STATE OF ILLINOIS WHITE COUNTY HIGHWAY DEPARTMENT	SUPERSTRUCTURE DETAILS STRUCTURE NO. 097-3266	T.R.	SECTION	COUNTY	TOTAL SHEETS	SHEET NO.
HAMPTON, LENZINI AND RENWICK, INC. 3535 STEVENSON DRIVE, SUITE 201 SPRINGFIELD, ILLINOIS 62765	PLOT SCALE =	CHECKED - S.W.M.	REVISED -			235	08-04126-00-BR	WHITE	13	8
HLR ILLINOIS PROFESSIONAL DESIGN FIRM LS / PE / SE CORP. 184.000569	PLOT DATE = 10/12/2010	DRAWN - D.T.M.	REVISED -			ENFIELD ROAD DISTRICT	CONTRACT NO. 99430			
		CHECKED - S.W.M.	REVISED -			ILLINOIS FED. AID PROJECT				

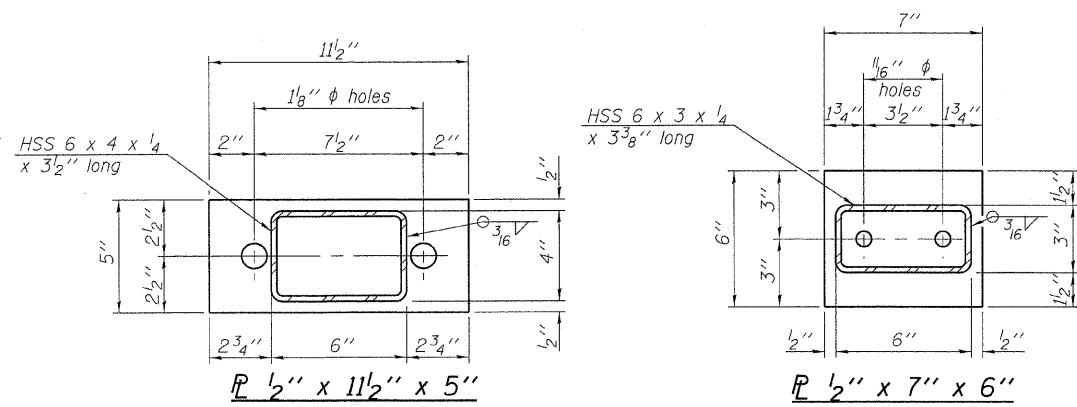
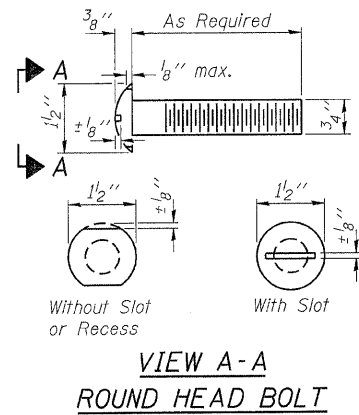

Note: Cost of curled end sections shall be included with the Steel Railing. (4 Required)

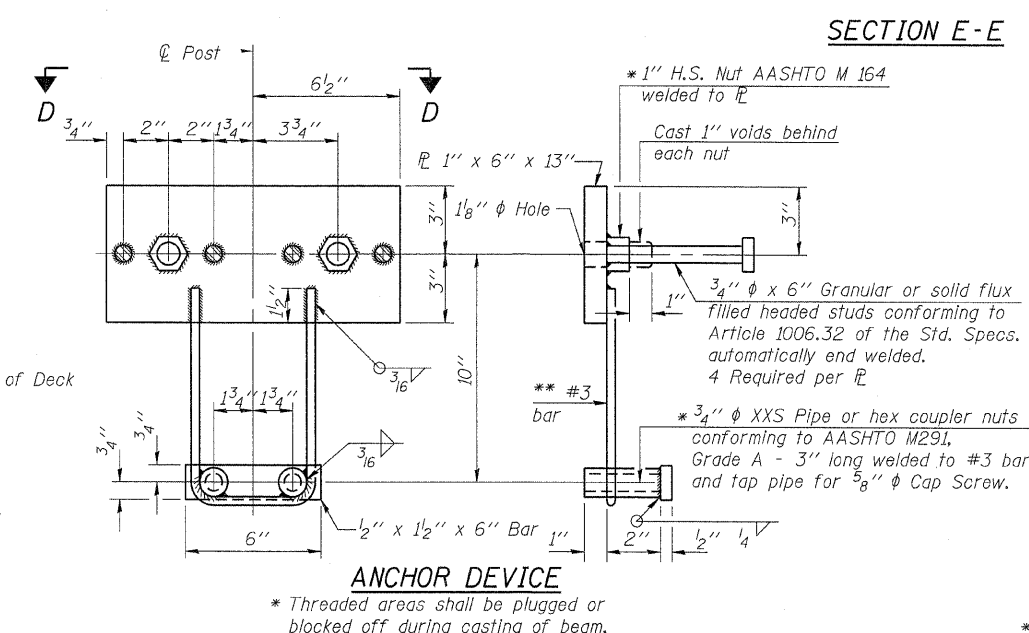
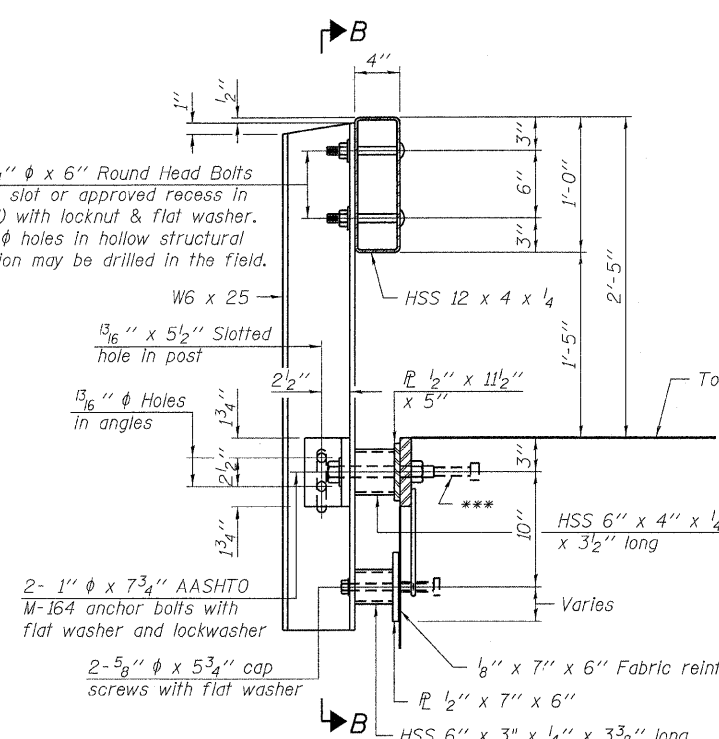
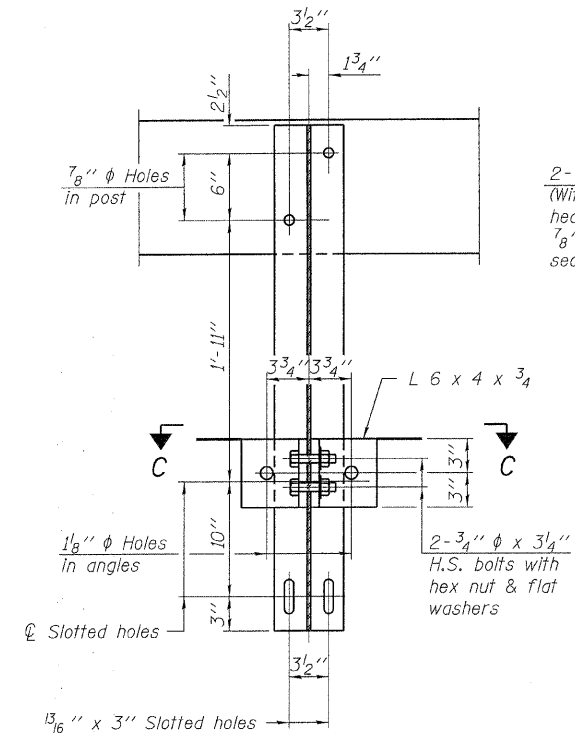
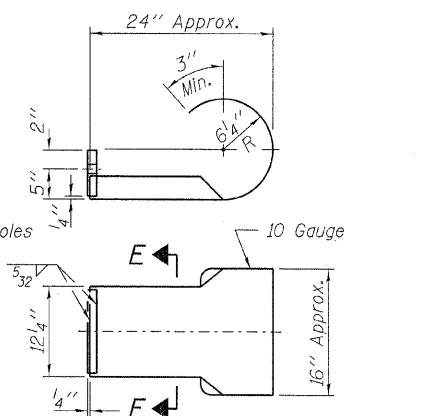
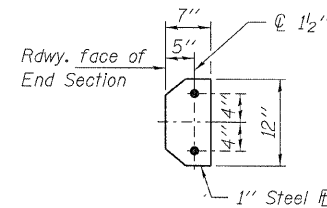

Notes:
 All field drilled holes shall be coated with an approved zinc rich paint before erection.
 For multi-span bridges, sufficient 1/4 inch x 6 inch x 1'-2 inch galvanized steel shims shall be provided to align rail between adjacent spans. Cost included with Steel Railing, Type S-1.
 All steel rail elements shall be galvanized according to Article 509.05 of the Standard Specifications.
 *** The studs of the anchor devices shall be placed below the top reinforcement bars and the outermost longitudinal reinforcement bar shall be placed directly above the studs of the rail post anchor device.

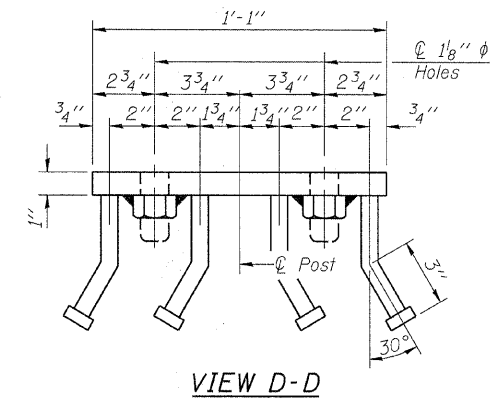
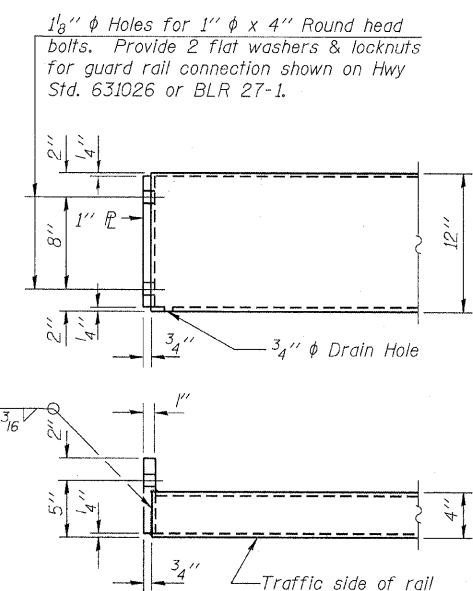
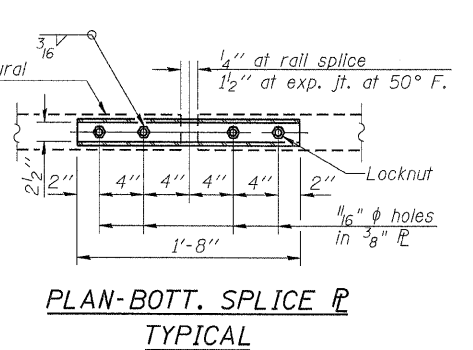
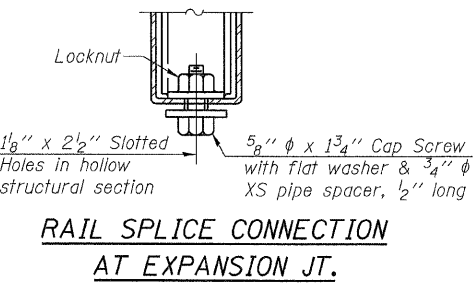
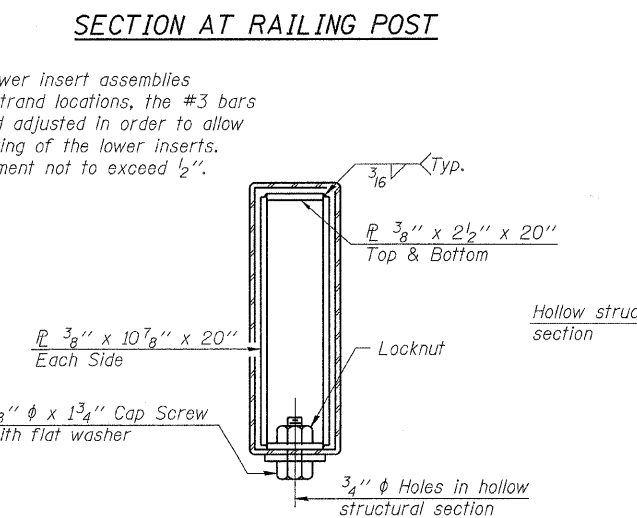
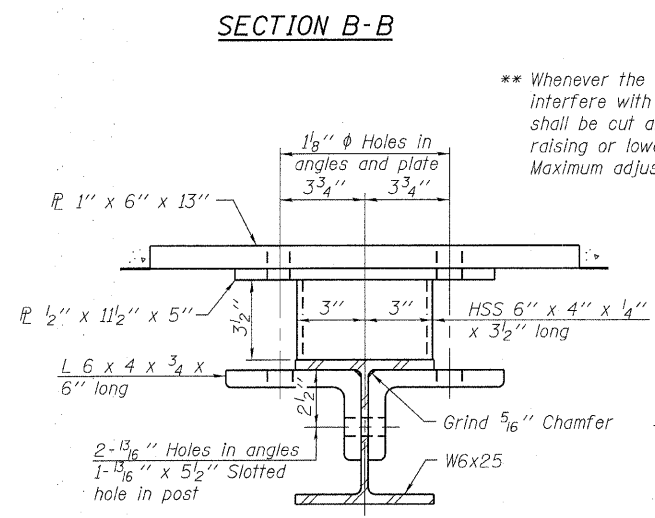

BILL OF MATERIAL

Item	Unit	Quantity
Steel Railing, Type S-1	Foot	105

R-23A 7-1-10 (10'-9" Maximum Post Spacing)

FILE NAME = 092050-shr-bridge.dgn	USER NAME =	DESIGNED - A.S.L.	REVISED - 01/18/10
HAMPTON, LENZINI AND RENWICK, INC. 3045 STEVENSON DRIVE, SUITE 101 SPRINGFIELD, ILLINOIS 62703	PLOT SCALE =	CHECKED - S.W.M.	REVISED -
ILLINOIS PROFESSIONAL DESIGN FIRM L.S./P.E./S.E. CORP. 184-00093	PLOT DATE = 10/12/2010	DRAWN - D.T.M.	REVISED -
		CHECKED - S.W.M.	REVISED -

STATE OF ILLINOIS
 WHITE COUNTY HIGHWAY DEPARTMENT

STEEL RAILING, TYPE S-1
 STRUCTURE NO. 097-3266

SHEET NO. 5 OF 9 SHEETS

T.R.	SECTION	COUNTY	TOTAL SHEETS	SHEET NO.
235	08-04126-00-BR	WHITE	13	9
ENFIELD ROAD DISTRICT		CONTRACT NO. 99430		
ILLINOIS FED. AID PROJECT				

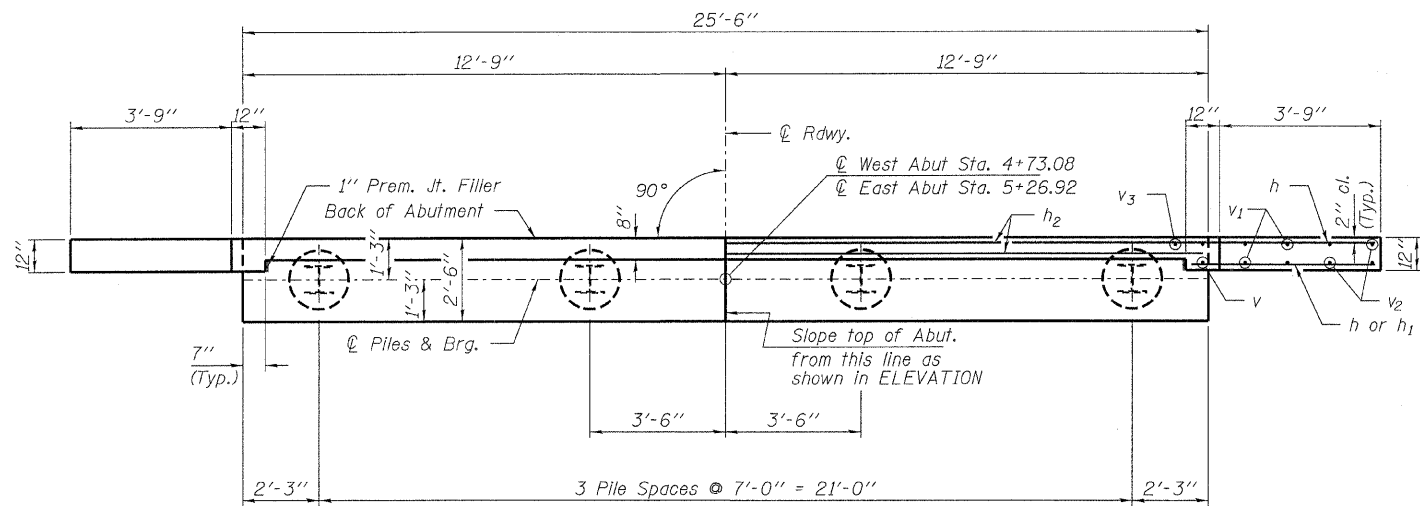

PLAN

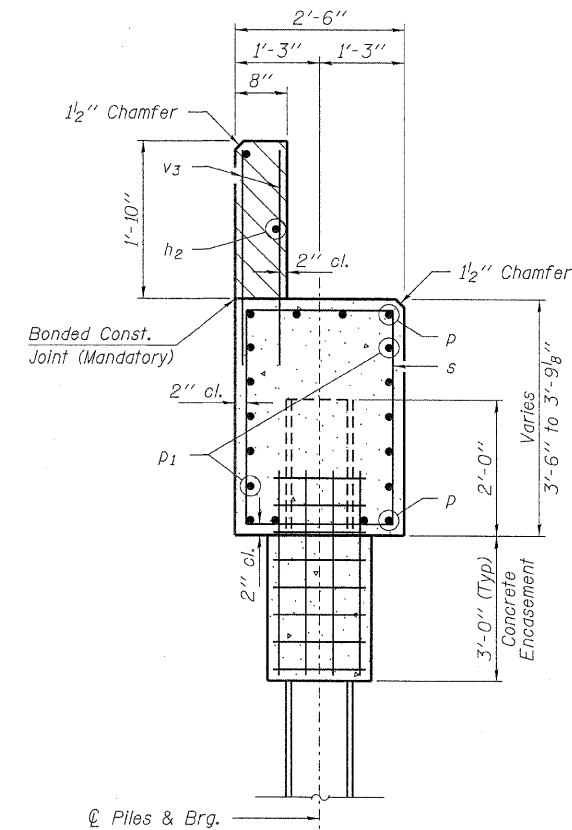

SECTION A-A

Hatched area to be poured after beams are in place.

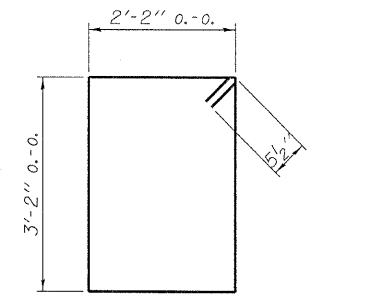

BAR s

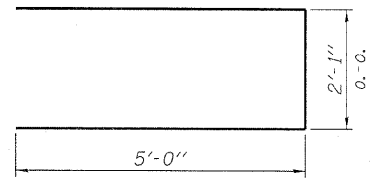

BAR u

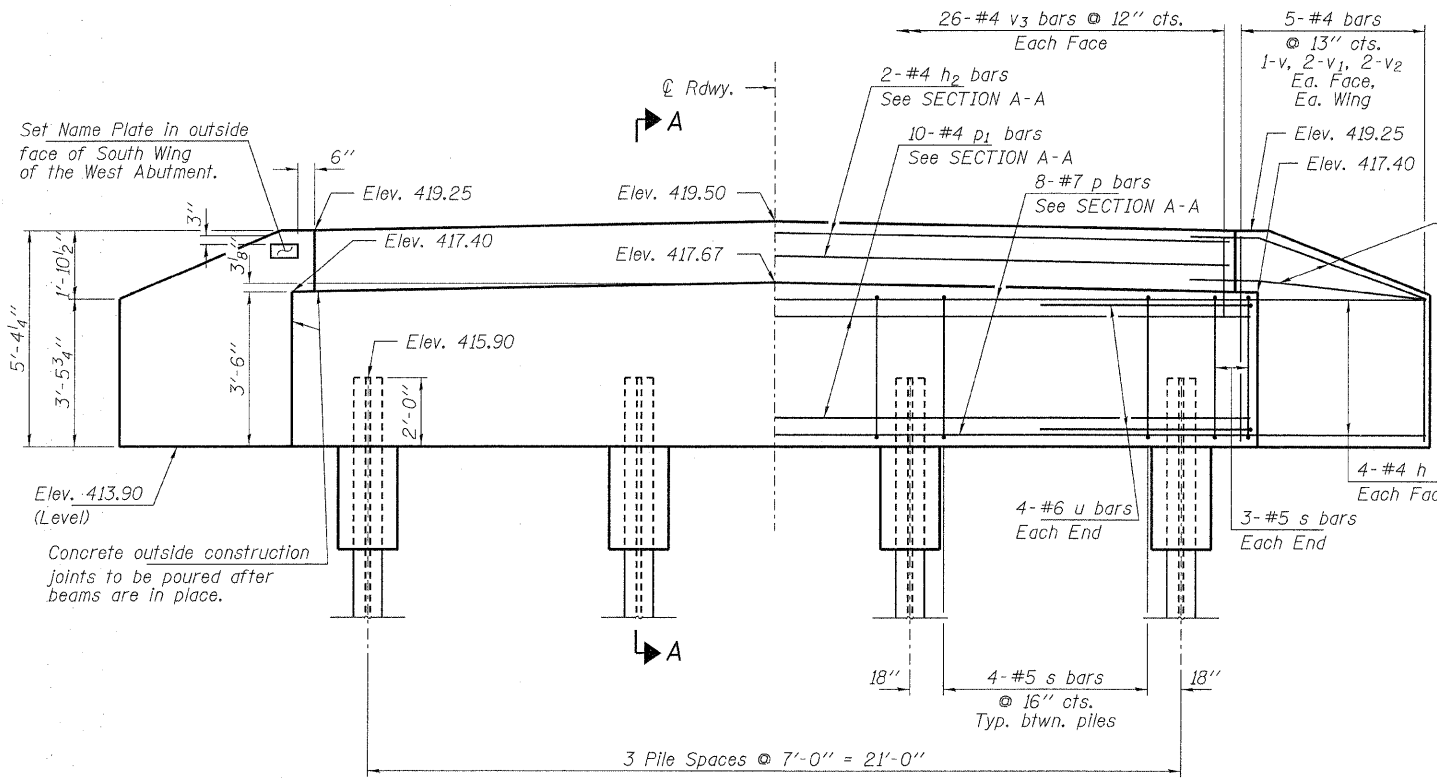

ELEVATION

PILE DATA

Type ----- Steel HP10x42
 No. Req'd. (2 Abutts.) ----- 8
 Factored Resistance Available (Rf) ----- 167 Kips/Pile
 Nominal Required Bearing (Rn) ----- 335 Kips/Pile
 Est. Length ----- .65 Ft/Pile

Notes: The Steel H-Piles shall be according to AASHTO M270 Grade 50.

BILL OF MATERIAL - 2 ABUTS.

BAR	NO.	SIZE	LENGTH	SHAPE
h	40	#4	6'-0"	—
h1	8	#4	4'-6"	—
h2	4	#4	25'-2"	—
p	16	#7	25'-2"	—
p1	20	#4	25'-2"	—
s	36	#5	11'-7"	□
u	16	#6	12'-1"	U
v	8	#4	5'-0"	—
v1	16	#4	4'-4"	—
v2	16	#4	3'-4"	—
v3	104	#4	2'-8"	—
Concrete Structures			Cu. Yd.	22.2
Concrete Encasement			Cu. Yd.	2.8
Reinforcement Bars			Pound	2,430
Steel Piles HP10x42			Foot	520
Name Plates			Each	1

FILE NAME = 090058-ah-bridge.dgn	USER NAME =	DESIGNED - A.S.L.	REVISED - 01/18/10
HAMPTON, LENZINI AND RENWICK, INC.		CHECKED - S.W.M.	REVISED -
3033 STEVENSON DRIVE, SUITE 201		DRAWN - D.T.M.	REVISED -
SPRINGFIELD, ILLINOIS 62703	PLOT SCALE =	CHECKED - S.W.M.	REVISED -
ILLINOIS PROFESSIONAL DESIGN FIRM	PLOT DATE = 10/12/2010		
LS / PE / SE CORP.			

STATE OF ILLINOIS
 WHITE COUNTY HIGHWAY DEPARTMENT

ABUTMENTS
 STRUCTURE NO. 097-3266

SHEET NO. 6 OF 9 SHEETS

T.R.	SECTION	COUNTY	TOTAL SHEETS	SHEET NO.
235	08-04126-00-BR	WHITE	13	10
ENFIELD ROAD DISTRICT			CONTRACT NO. 99430	
[ILLINOIS] FED. AID PROJECT				

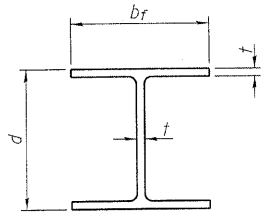

STEEL PILE TABLE

Designation	Depth d	Flange width b _f	Web and Flange thickness t	Encasement diameter A
HP 14x117	14 1/4"	14 7/8"	13/16"	30"
x102	14"	14 3/4"	1/16"	30"
x89	13 7/8"	14 3/4"	5/8"	30"
x73	13 5/8"	14 5/8"	1/2"	30"
HP 12x84	12 1/4"	12 1/4"	1/16"	24"
x74	12 1/8"	12 1/4"	5/8"	24"
x63	12"	12 1/8"	1/2"	24"
x53	11 3/4"	12"	7/16"	24"
HP 10x57	10"	10 1/4"	9/16"	24"
x42	9 3/4"	10 1/8"	7/16"	24"
HP 8x36	8"	8 1/8"	7/16"	18"

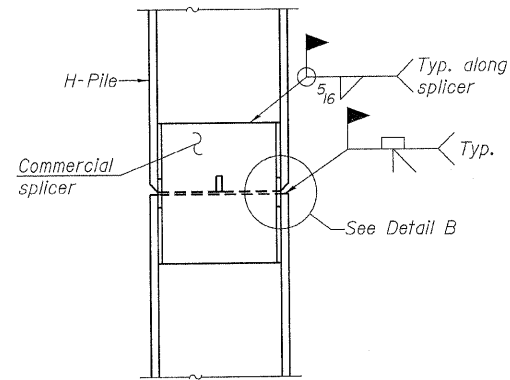

ELEVATION

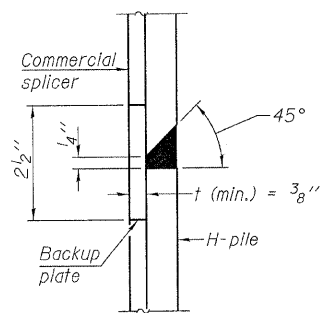

DETAIL "B"

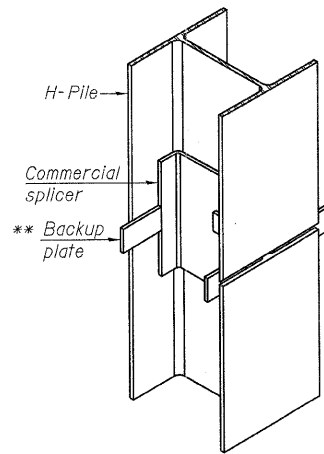

ISOMETRIC VIEW

WELDED COMMERCIAL SPLICE

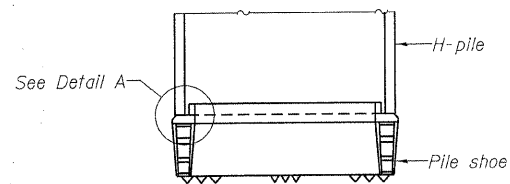

ELEVATION

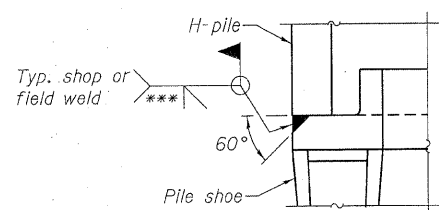

DETAIL A

H-PILE SHOE ATTACHMENT

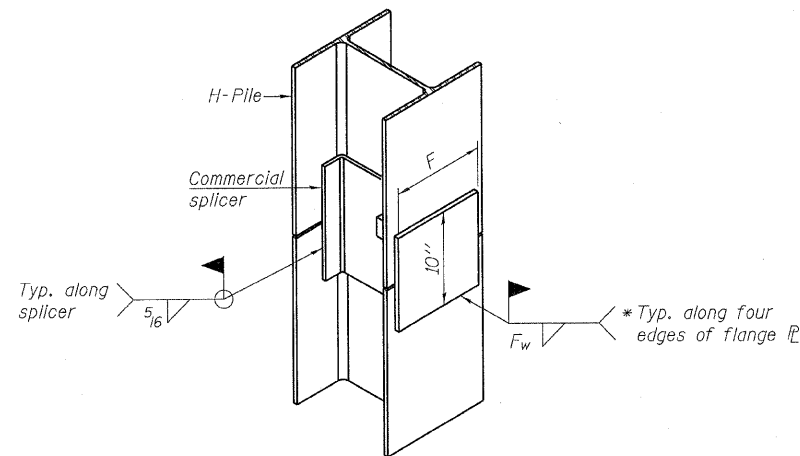

ISOMETRIC VIEW

WELDED COMMERCIAL SPLICE ALTERNATE

- * Interrupt welds 1/4" from end of web and/or each flange.
- ** Remove portions of backup plates that extend outside the flanges.
- *** Weld size per pile shoe manufacturer (5/16" min.).

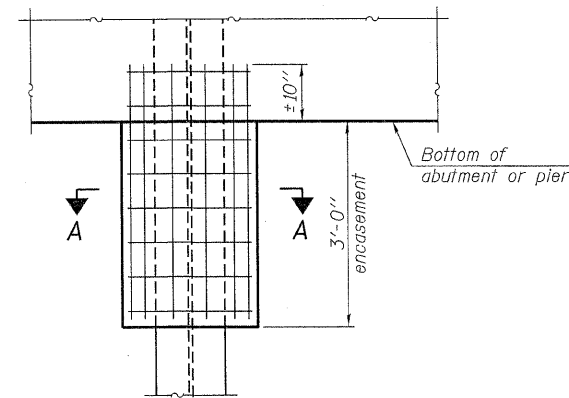

ELEVATION

PILE ENCASEMENT

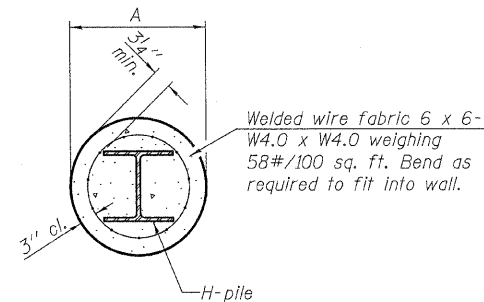

SECTION A-A

Note:
Forms for encasement may be omitted when soil conditions permit.

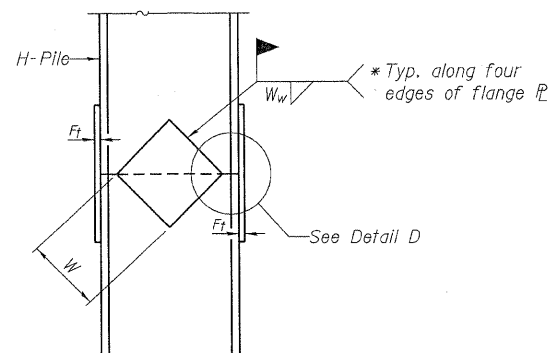

ELEVATION

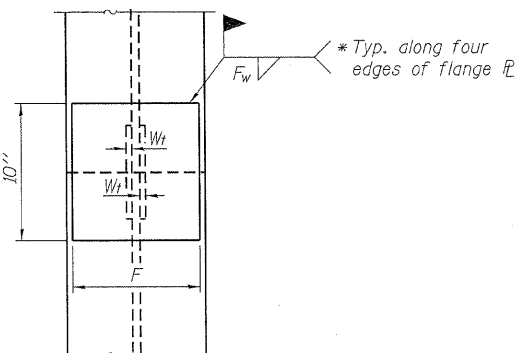

END VIEW

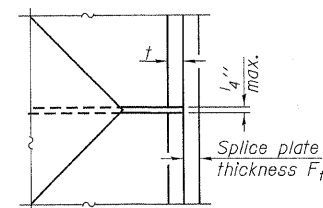

DETAIL D

WELDED PLATE FIELD SPLICE

Designation	F	F _t	F _w	W	W _t	W _w
HP 14x117	12 1/2"	1"	7/8"	7 3/4"	5/8"	1/2"
x102	12 1/2"	7/8"	3/4"	7 3/4"	5/8"	1/2"
x89	12 1/2"	3/4"	1/16"	7 3/4"	5/8"	1/2"
x73	12 1/2"	5/8"	9/16"	7 3/4"	5/8"	1/2"
HP 12x84	10"	7/8"	1/16"	6 1/2"	5/8"	1/2"
x74	10"	7/8"	1/16"	6 1/2"	5/8"	1/2"
x63	10"	5/8"	1/2"	6 1/2"	1/2"	3/8"
x53	10"	5/8"	1/2"	6 1/2"	1/2"	3/8"
HP 10x57	8"	3/4"	9/16"	5 1/4"	1/2"	3/8"
x42	8"	5/8"	9/16"	5 1/4"	1/2"	3/8"
HP 8x36	7"	5/8"	7/16"	4 1/4"	1/2"	3/8"

Note:
The steel H-piles shall be according to AASHTO M270 Grade 50.

F-HP

7-1-10

FILE NAME = 092058-sh-t-bridge.dgn	USER NAME =
HAMPTON, LENZINI AND RENWICK, INC. 3335 STEVENSON DRIVE, SUITE 201 SPRINGFIELD, ILLINOIS 62763 ILLINOIS PROFESSIONAL DESIGN FIRM L9 / PE / SE CORP. 184.000559	PLOT SCALE =
	PLOT DATE = 10/12/2010

DESIGNED - A.S.L.	REVISIONS - 01/18/10
CHECKED - S.W.M.	REVISIONS -
DRAWN - D.T.M.	REVISIONS -
CHECKED - S.W.M.	REVISIONS -

STATE OF ILLINOIS
WHITE COUNTY HIGHWAY DEPARTMENT

HP PILE DETAILS
STRUCTURE NO. 097-3266

SHEET NO. 7 OF 9 SHEETS

T.R.	SECTION	COUNTY	TOTAL SHEETS	SHEET NO.
235	08-04126-00-BR	WHITE	13	11
ENFIELD ROAD DISTRICT			CONTRACT NO. 99430	
ILLINOIS FED. AID PROJECT				

Bridge Foundation Boring Log

Project: H-09189 Bridge Co Rd 1200 N Date: 8/4/09
 Section: 08-04126-00-BR Station _____ Bored by: D. Russell
 Structure: _____ Checked By: J. Holcomb
 County: White

Boring No: 1
 Station: _____
 Offset: _____

Surface Water Elev. _____
 Ground Water Elev. 400.2
 During Drilling
 Upon Completion 391.2

Description	Elevation	N	Qu tsf	w %	Surface Water Elev.	Ground Water Elev.	During Drilling	Upon Completion	Elevation	N	Qu tsf	w %
Ground Surface	417.2	0										
6" Crushed Stone and Clay Mix												
Gray Mottled Brown Silty CLAY (A-6)		6	1.0S	24					-25	10	2.7B	15
									390.7			
Gray Mottled Brown Sandy CLAY (A-6)		5	1.6B	22					-5	14	4.3B	13
									388.2			
Gray Sandy CLAY (CL) A-6		5	1.0B	23					-30	20	3.9B	13
									408.2			
Brown Mottled Gray Sandy CLAY (A-6)		6	2.1S	18					-10			
									383.2			
Gray Fine to Medium SAND (A-2-4)		5	1.4B	18					-35	1	--	18
									400.7			
Brown Clayey SAND (A-2-4)		5	1.4S	19					-15			
									400.7			
Gray CLAY (A-6)		12	--	20					-40	15	2.7B	26
									378.2			
Brown-Gray Sandy CLAY (A-6)		11	3.1S	14					-20			
									398.2			
Gray-Brown CLAY (A-6)		10	1.7S	20					-20			
Gray Sandy SILT (A-4)									395.7			
									373.2			

N = Standard Penetration Test Blows per foot to drive 2" O.D. Split Spoon Sampler 12" with a 140 lbs. hammer falling 30"
 Qu - Unconfined Compressive Strength in tons/sq.ft.
 w - Water Content - percentage of oven dry weight-%
 B = Bulge Failure
 S = Shear Failure
 E = Estimated Value
 P = Penetrometer

Bridge Foundation Boring Log

Project: H-09189 Bridge Co Rd 1200 N Date: 8/4/09
 Section: 08-04126-00-BR Station _____ Bored by: D. Russell
 Structure: _____ Checked By: J. Holcomb
 County: White

Boring No: 1
 Station: _____
 Offset: _____

Surface Water Elev. _____
 Ground Water Elev. 400.2
 During Drilling
 Upon Completion 391.2

Description	Elevation	N	Qu tsf	w %	Surface Water Elev.	Ground Water Elev.	During Drilling	Upon Completion	Elevation	N	Qu tsf	w %
silt (continued)	45.9		1.4B	25								
									-70			
									390.7			
Gray Mottled Brown Sandy CLAY (A-6)		8	0.7B	23					-50			
									388.2			
Gray SHALE									-75			
									363.2			
Gray Mottled Brown Sandy CLAY (A-6)		61	1.4S	18					-55			
									383.2			
Gray SHALE									-80			
									358.2			
Gray SHALE		100	/2"	-- 7					-60			
									400.7			
Gray SHALE		100	/5"	-- 5					-85			
									378.2			
Gray SHALE		100	/3"	-- 6					-85			
									400.7			
End of Boring @ -64.0'									-65			

N = Standard Penetration Test Blows per foot to drive 2" O.D. Split Spoon Sampler 12" with a 140 lbs. hammer falling 30"
 Qu - Unconfined Compressive Strength in tons/sq.ft.
 w - Water Content - percentage of oven dry weight-%
 B = Bulge Failure
 S = Shear Failure
 E = Estimated Value
 P = Penetrometer

BORING 1

