

U-25

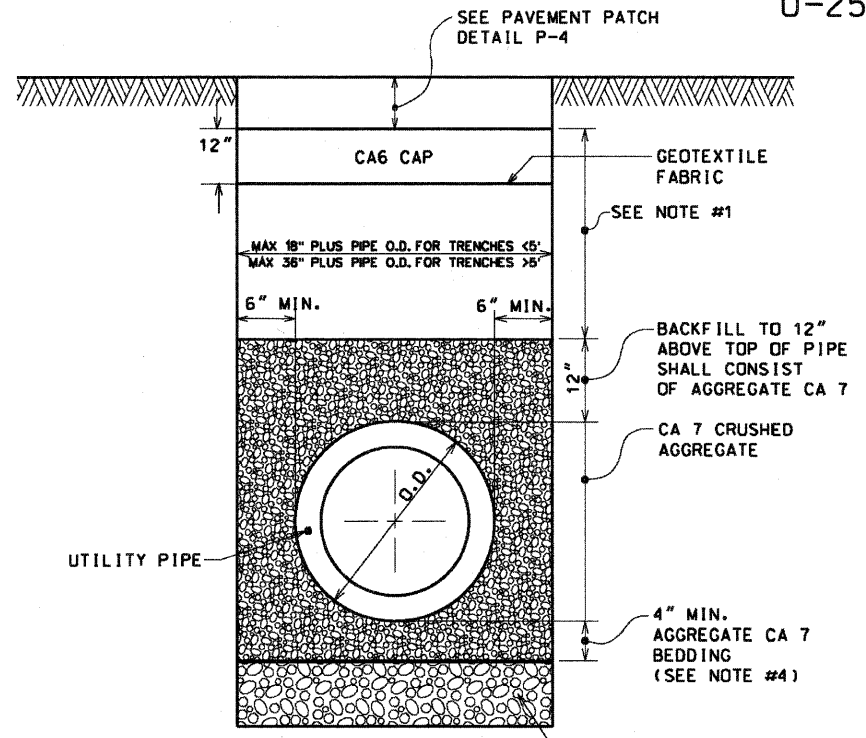

- NOTES:**
- TRENCH BACKFILL UNDER A PAVED SURFACE OR WITHIN THE ZONE OF INFLUENCE (5' FROM EDGE OF PAVEMENT) SHALL CONSIST OF:
 - UNDER NEW PAVEMENT: 12" THICK PAVEMENT SUBGRADE (AGGREGATE CA 6 CAP) OVER AGGREGATE CA-7 TRENCH BACKFILL OR CONTROLLED LOW STRENGTH MATERIAL (CLSM) MIX 1 (ONLY IF REQUIRED BY VILLAGE ENGINEERING)
 - UNDER EXISTING PAVEMENT: SAME AS 'a' ABOVE
 - UNDER PRIVATELY OWNED PAVEMENT: SAME AS 'a' ABOVE.
 - ALL MATERIALS SHALL BE PROPERLY COMPACTED PER SPECIFICATIONS (INUNDATION OR WATER JETTING IS NOT ALLOWED).
 - ALL TRENCH EXCAVATIONS SHALL MEET OSHA REQUIREMENTS.
 - BEDDING MATERIAL FOR PVC PIPE INSTALLATION SHALL COMPLY WITH ASTM D-2321.
 - IF APPROVED BY VILLAGE ENGINEERING, A ONE (1) INCH THICK STEEL PLATE SHALL BE PROVIDED AND MAINTAINED BY CONTRACTOR UNTIL THE SURFACE RESTORATION IS COMPLETE. THE PLATE SHALL BE PROTECTED FROM SLIDING AND PROVIDED WITH BITUMINOUS RAMPS IF REQUIRED BY VILLAGE ENGINEERING.
 - PRIOR TO PLACEMENT OF PAVEMENT MATERIALS, THE EXISTING EXPOSED EDGES SHALL BE SANICUT TO PROVIDE A SMOOTH CLEAN EDGE - FREE OF LOOSE MATERIAL.
 - THE PLACEMENT OF PAVEMENTS SHALL NOT BE ALLOWED WITHOUT PRIOR APPROVAL BY VILLAGE ENGINEERING.

NOT TO SCALE
**UTILITY TRENCH
 IN PAVEMENT
 AREAS DETAIL**

REVISED:01-01-09

U-27

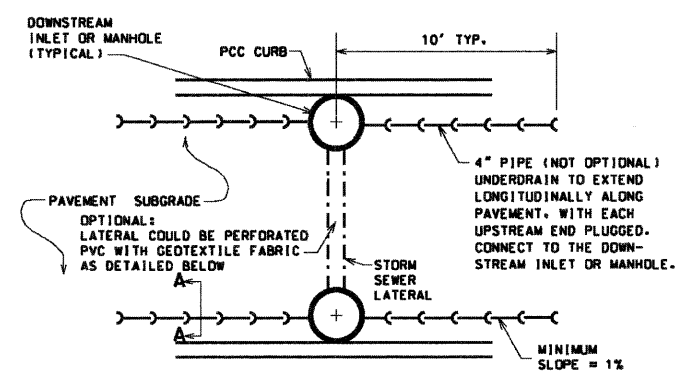

PIPE UNDERDRAIN PLAN VIEW

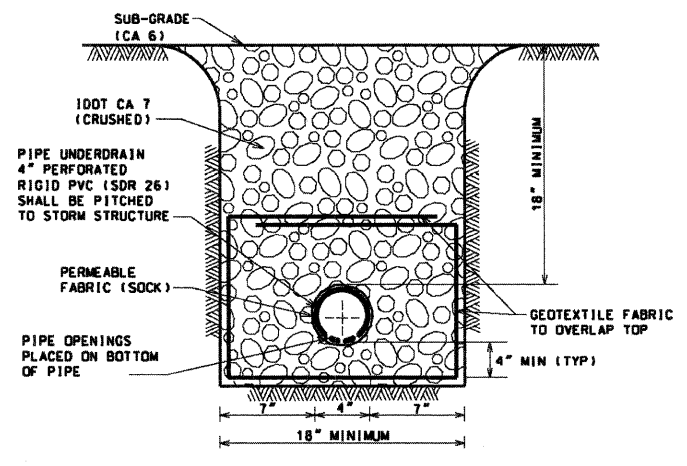

SECTION A-A

NOTE:
 UNDERDRAIN TO BE INSTALLED IF INDICATED ON PLANS AND/OR REQUESTED BY VILLAGE ENGINEERING.

NOT TO SCALE
**PIPE UNDERDRAIN
 DETAIL**

REVISED:01-01-09

PAID FOR AS PIPE UNDERDRAINS, FABRIC LINED TRENCH 4"

FILE NAME = J:\2275\Cad\Sheet\2275_DET_18.dgn

USER NAME = djc	DESIGNED - JAT	REVISED -
PLOT SCALE = 50.0000' / IN.	DRAWN - JAT	REVISED -
PLOT DATE = 11/20/2009	CHECKED - DJK	REVISED -
	DATE - 11-23-09	REVISED -

**STATE OF ILLINOIS
 DEPARTMENT OF TRANSPORTATION**

VILLAGE OF GLENVIEW CONSTRUCTION DETAILS

SHEET NO. 7 OF 9 SHEETS

F.A.U. RTE. 2743	SECTION 05-00161-00-CH	COUNTY COOK	TOTAL SHEETS 112	SHEET NO. 88
CONTRACT NO. 63383				
FED. ROAD DIST. NO. 1 ILLINOIS FED. AID PROJECT M-8003643				