

INLET FILTERS

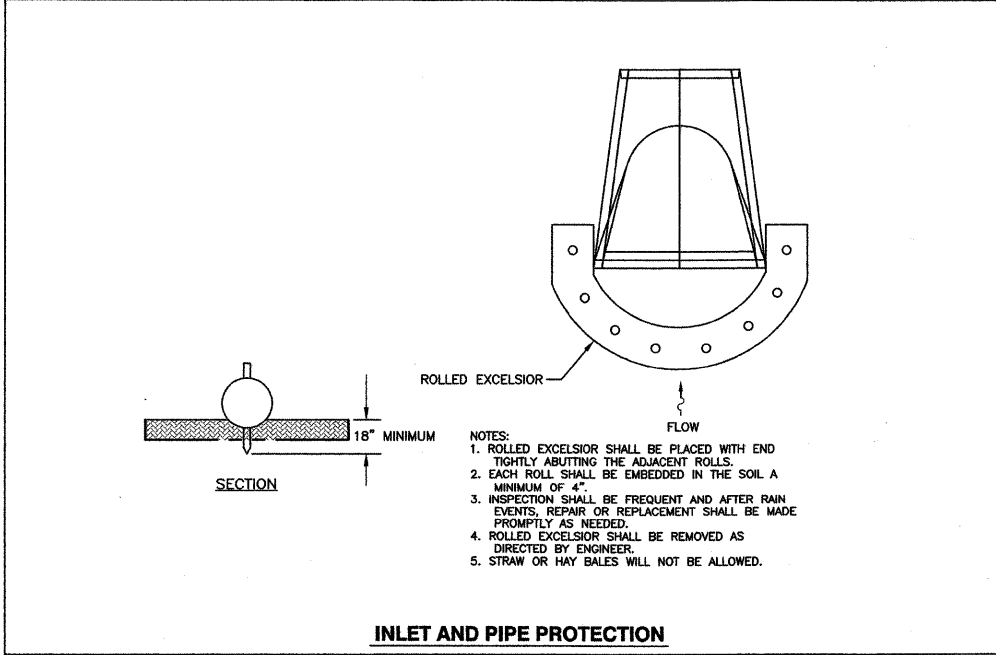

INLET AND PIPE PROTECTION

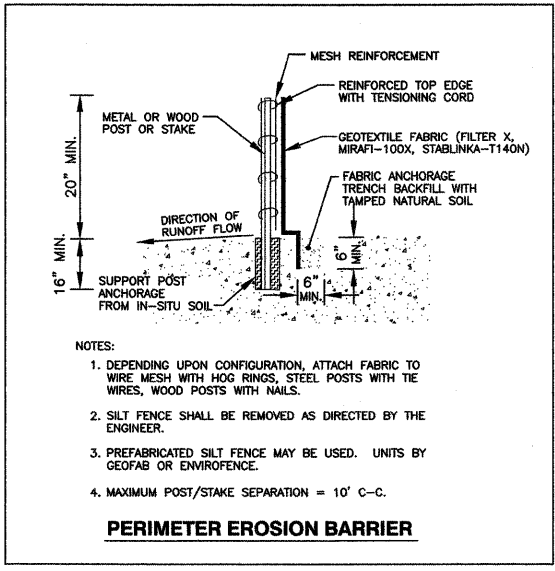

PERIMETER EROSION BARRIER

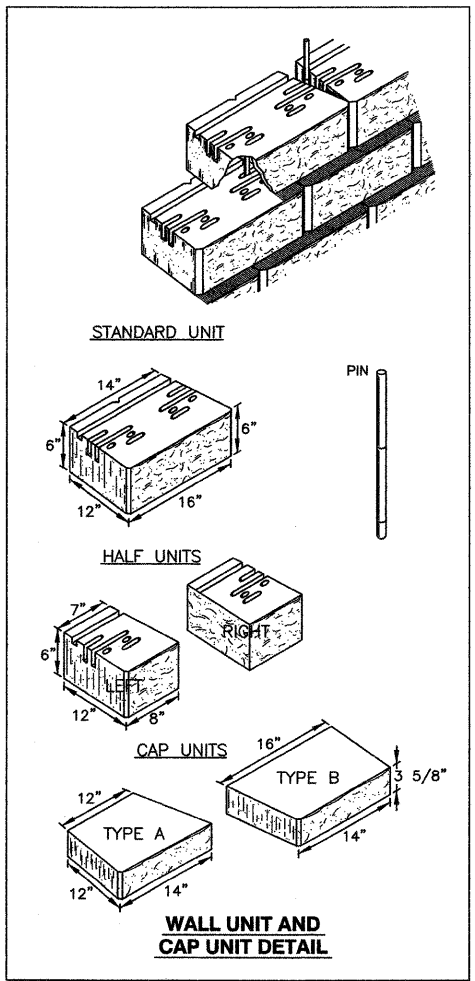

WALL UNIT AND CAP UNIT DETAIL

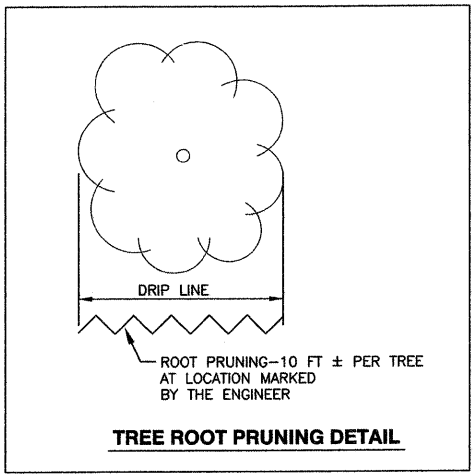

TREE ROOT PRUNING DETAIL

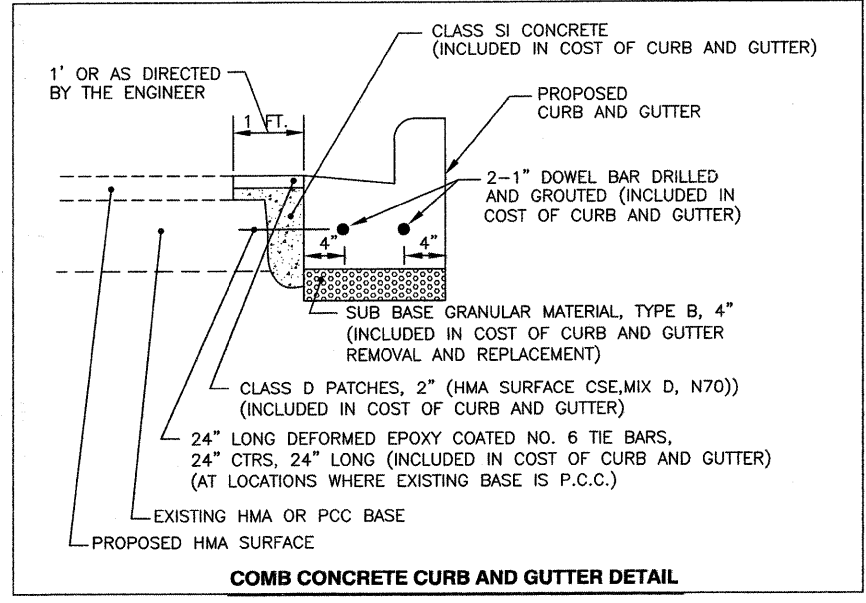

COMB CONCRETE CURB AND GUTTER DETAIL

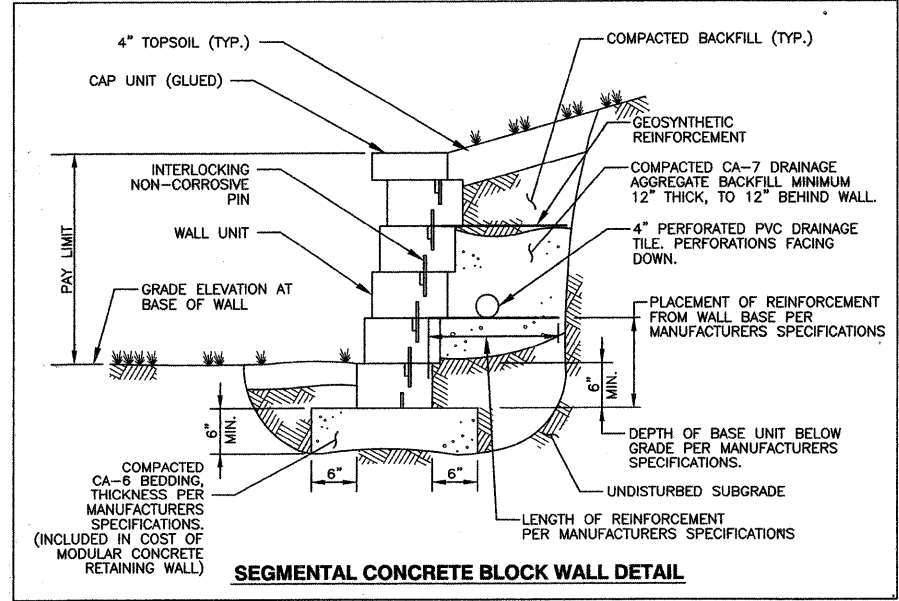

SEGMENTAL CONCRETE BLOCK WALL DETAIL

JJB JAMES J. BENES & ASSOCIATES, INC.
 950 Warrenville Road, Suite 101, Lisle, Illinois 60532
 Tel. (630) 719-7570 • Fax (630) 719-7589

FILE NAME =	USER NAME =	DESIGNED -- BDH	REVISED --	STATE OF ILLINOIS DEPARTMENT OF TRANSPORTATION	CONSTRUCTION DETAILS F.A.P. ROUTE 351 (IL ROUTE 7)		F.A.P. RTE.	SECTION	COUNTY	TOTAL SHEETS	SHEET NO.
		DRAWN -- SMP	REVISED --		351	09-00063-00-SW	WILL	41	15		
		CHECKED -- BDH	REVISED --		SCALE: NONE SHEET NO. 15 OF 41 SHEETS STA. _____ TO STA. _____		CONTRACT NO. 63438		ILLINOIS FED. AID PROJECT		
		DATE -- 11-06-09	REVISED --								