

STATE OF ILLINOIS  
DEPARTMENT OF TRANSPORTATION

F.A.P. RTE.	SECTION	COUNTY	TOTAL SHEETS	SHEET NO.
VAR.	(17, 110, 111)RS-5; 18RS-6	FULTON	52	1
		ILLINOIS	CONTRACT NO. 68K17	

FOR INDEX OF SHEETS, SEE SHEET NO. 2  
HIGHWAY STANDARDS

000001-09	631031-18	701301-04	780001-05
001006	635001-02	701306-04	781001-04
482011-03	642011	701311-03	
606301-04	701006-05	701901-11	
630001-13	701011-04	720001-01	
630301-09	701201-05	720006-04	

DISTRICT STANDARDS

406101-D4	630101-D4
406201-D4	780001-D4
406402-D4	780002-D4

# PROPOSED HIGHWAY PLANS

FAP ROUTE 0317 / FAP ROUTE 0315 (US 24 )  
SECTION: (17, 110, 111)RS-5; 18RS-6  
PROJECT NHPP-13QV(934)  
RESURFACING (3P)  
FULTON COUNTY  
C-94-066-25

D-94-052-25

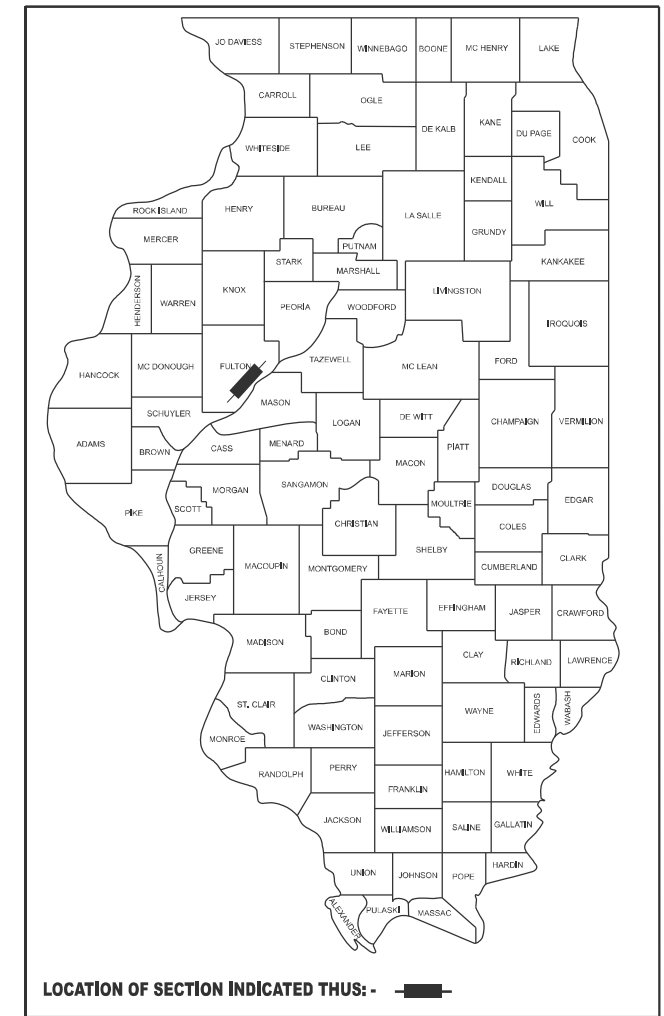

PROJECT DESCRIPTION: IMPROVEMENTS INCLUDE STANDARD OVERLAY, SMART OVERLAY, PROPOSED HMA SHOULDERS, PAVEMENT MARKINGS, AND ALL OTHER RELATED COLLATERAL WORK ON US 24 BETWEEN IZAACK WALTON RD AND NORTH OF RUT RD

FUNCTIONAL CLASS = OTHER PRINCIPAL ARTERIAL

US 24 ADT = 1700-2500(2023)

STATION EQUATIONS(US 24)

STA. 84+51.98(BK) = STA. 85+00.00(AH)  
STA. 274+73.10(BK) = STA. 275+06.66(AH)  
STA. 447+60.51(BK) = STA. 447+40.82(AH)  
STA. 514+96.62(BK) = STA. 653+01.18(AH)

STATION EQUATIONS(US 136 / IL 100)

STA. 106+21.42(BK) = STA 8+19.42(AH)

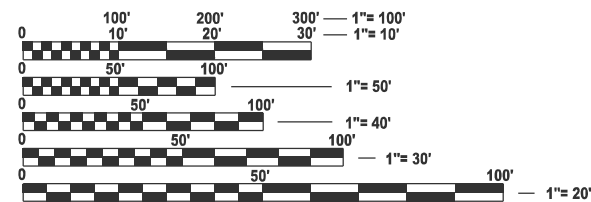

FULL SIZE PLANS HAVE BEEN PREPARED USING STANDARD ENGINEERING SCALES. REDUCED SIZED PLANS WILL NOT CONFORM TO STANDARD SCALES. IN MAKING MEASUREMENTS ON REDUCED PLANS, THE ABOVE SCALES MAY BE USED.

J.U.L.I.E.  
JOINT UTILITY LOCATION INFORMATION FOR EXCAVATION  
1-800-892-0123  
OR 811

PROJECT ENGINEER: DAVID BROVIK, PE  
PROJECT MANAGER: MICHAEL WITTKOP, PE

CONTRACT NO. 68K17

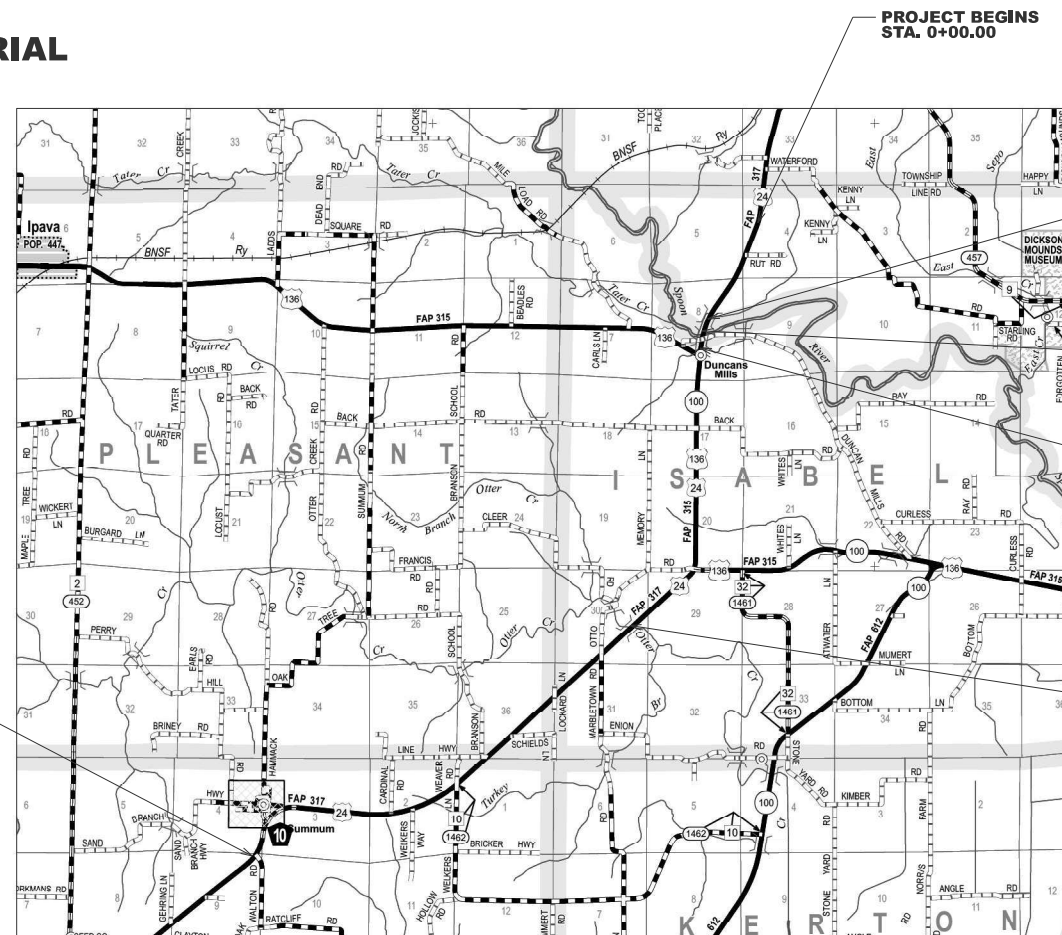

PROJECT BEGINS  
STA. 0+00.00

BRIDGE OMISSION  
SN 029-0067  
STA. 64+27.41 TO  
STA. 65+80.21

BRIDGE OMISSION  
SN 029-0068  
STA. 70+25.37 TO  
STA. 78+01.29

BRIDGE OMISSION  
SN 029-0060  
STA. 83+60.77 TO STA. 84+51.98  
STA. EQN STA. 84+51.98(BK) = STA. 85+00.00(AH)  
STA. 85+00.00 TO 85+29.77

BRIDGE OMISSION  
SN 029-0005  
STA. 255+73.57 TO  
STA. 258+92.86

PROJECT ENDS  
STA. 663+60.76

GROSS LENGTH = 52495 FT. = 9.94 MILE  
NET LENGTH = 51126 FT. = 9.68 MILE



Justin L. Godwin 1-27-2026  
ILLINOIS P.E. NO. 062-055333  
EXPIRES: 11-30-2027

STATE OF ILLINOIS  
DEPARTMENT OF TRANSPORTATION

SUBMITTED Jan. 29, 2026

*Kensil A. Garnett KSD*  
REGIONAL ENGINEER

March 20, 2026  
*See E.A. [Signature]*  
ENGINEER OF DESIGN AND ENVIRONMENT

March 20, 2026  
*[Signature]*  
DIRECTOR OF HIGHWAYS PROJECT IMPLEMENTATION

PRINTED BY THE AUTHORITY  
OF THE STATE OF ILLINOIS

# INDEX OF SHEETS

SHEET NO.	ITEM
1	COVER SHEET
2	GENERAL NOTES
3-4	SUMMARY OF QUANTITIES
5-13	TYPICAL SECTIONS
14-18	SCHEDULE OF QUANTITIES
19-38	PLAN SHEETS
39-41	DETAIL SHEETS
42-52	DISTRICT STANDARD DETAILS

## GENERAL NOTES

### AVAILABILITY OF ELECTRONIC FILES

OpenRoads Designer files of this project will be made available to the Contractor after contract award. If there is a conflict between the electronic files and the printed contract plans and documents, the printed contract plans and documents shall take precedence over the electronic files. The Contractor shall accept all risk associated with using the electronic files and shall hold the Department harmless for any errors or omissions in the electronic files and the data contained therein. Errors or delays resulting from the use of the electronic files by the Contractor shall not result in an extension of time for any interim or final completion date or shall not be considered cause for additional compensation. The Contractor shall not use, share, or distribute these electronic files except for the purpose of constructing this contract. Any claims by third parties due to use or errors shall be the sole responsibility of the Contractor. The Contractor shall include this disclaimer with the transfer of these electronic files to any other parties and shall include appropriate language binding them to similar responsibilities.

### COMMITMENTS

Commitments are not to be altered without the written approval of all parties to which the commitment was made.

### TEMPORARY MATERIAL REQUIREMENTS - UTILITY AND DRIVEWAY CLOSURES

Incidental hot-mix asphalt surface shall be used for all temporary side road crossings. Aggregate surface course may be used for all driveway crossings except during winter shutdown in accordance with Article 107.09.

### WINTER SHUTDOWN RESTRICTIONS ON COLD MILLED PROJECTS

Prior to winter shutdown manholes, where applicable, shall be adjusted to the elevation of the binder course/leveling binder to ease in plowing snow, and re-adjusted to finished grade in the Spring. The initial manhole adjustment will be paid for at the contract unit price and any re-adjustment, as directed by the Engineer, will be paid for in accordance with Article 109.04

### ENVIRONMENTAL REVIEWS

Prior to the use of any proposed borrow areas, use areas (temporary access roads, detours, run-arounds, etc.) and/or waste areas, the Contractor shall file the required environmental resource request surveys according to Section 107.22 of the Standard Specifications. These surveys are required in order for the Department to conduct cultural and biological resource surveys for the proposed site. The required environmental resource documentation shall include the following:

- BDE Form 2289 (Borrow Site Review)
- BDE Form 2290 (Waste/Use Area Review)
- A location map showing the size limits and location of the use area
- Color photographs depicting the use area
- Borrow Area Entry Agreement form – D4 PI0101

Prior to any waste materials being removed from the construction site the required environmental resource surveys shall be obtained and filed by the Contractor. Excess waste products removed from the construction site shall be disposed of as required in Section 202.03 of the Standard Specifications. Any protruding metal bars shall be removed prior to the disposal of broken concrete at approved disposal sites. Please note that a minimum of four weeks shall be allowed for the District to obtain the required waste site environmental clearances and six weeks for the required borrow site environmental clearances

### PAVEMENT STATION NUMBERS & PLACEMENT

The Contractor shall provide labor and materials required to imprint pavement station numbers in the finished surface of the pavement and/or overlay. The numbers shall be approximately 3/4 inch (20 mm) wide, 5 inches (125 mm) high and 5/8 inch (15 mm) deep.

The pavement station numbers shall be installed as specified herein:

Interval - 200 feet (English stationing) or 100 meters (metric stationing)

Bottom of Numbers - 6 inches (150 mm) from the inside edge of the pavement marking Location:

- 2, 3, & 5 Lane Pavements - right edge of pavement in direction of increasing stations

- Multi-Lane Divided Roadways - outside edge of pavement in both directions  
- Ramps - along baseline edge of pavement

Position - stations shall be placed so they can be read from the adjacent shoulder

Format - English (Metric) pavement stations shall use this format "XXX (XX+X00)", where X represents the pavement station

This work will not be paid for separately, but will be included in the cost of the associated pavement and/or overlay pay items.

### POLYMERIZED BITUMINOUS MATERIALS (TACK COAT) RATES

Surface Type	Residual Rate
Milled (HMA or PCC)	0.08 lb/sf
Existing Pavement	0.08 lb/sf
Fog Coat (between lifts)	0.08 lb/sf

### PAVING SURFACE COURSE

Continuous paving operations on the main roadway shall be maintained at all times during the construction of the hot-mix asphalt surface. No interruptions for side roads, entrances, turn lanes, etc. will be allowed.

### CROSSING EXISTING STRUCTURES WITH EQUIPMENT

The following structures, SN 029-0005, SN 029-0060, SN 029-0067, SN 029-0068, may be crossed with the empty Material Transfer Device (MTD) with a maximum gross weight restriction of 40 tons.

### ADDITIONAL SUPPLEMENTAL TRAFFIC CONTROL

The Department reserves the right at any time to add additional Traffic Control Systems or devices within the active contract limits, by means of an additional contract. All terms of Article 105.08 of the Standard Specifications shall be followed by each Contractor.

### NO PASSING ZONE VERIFICATION

The resident shall contact Operations to verify the location of no passing zones prior to placement of centerline striping

## PROJECT SPECIFIC NOTES

### EXISTING CENTERLINE ALIGNMENT

The existing centerline alignment provided in the plans was approximated using available aerial imagery. Stationing was estimated from stamped pavement markings located in the field. Provided station and offset callouts in the plans are intended to provide relative location of elements estimated from the aerial imagery and is not intended to match monuments found in the field.

The use of reclaimed asphalt pavement (RAP) as Aggregate Shoulders, or Aggregate Wedge Shoulder, Type B is not allowed on this project.

### HOT-MIX ASPHALT MIXTURE REQUIREMENTS

The following mixture requirements are applicable for this project:

Location(s):	Mainline	Mainline	Mainline	Shoulders	Shoulders		Mainline	Incidental
Mixture Use(s):	Polymer Surface 1.5"	Polymer Surface 1.75"	Polymer Level Binder 1"	Shoulder Surface Lift 1.5"	Shoulder Binder Lift 1.25"		Class D Patching	Incidental Surface
AC/PG:	SBS or SBR 70-28	SBS or SBR 70-28	SBS or SBR 70-28	PG 58-28	PG 58-28		PG 58-28	PG 58-28
Design Air Voids:	4.0% @ N=50	4.0% @ N=50	4.0% @ N=50	4.0% @ N=50	4.0% @ N=50		4.0% @ N=50	4.0% @ N=50
Mixture Composition: (Mixture Gradation)	IL 9.5	IL 9.5	IL 4.75	IL 9.5 FG	IL 9.5 FG		IL 19.0	IL 9.5
Friction Aggregate:	Mix D	Mix D	N/A	Mix C	N/A		N/A	Mix C
Quality Management Program:	PFP	PFP	QCP	QCQA	QCQA		QCQA	QCQA
MTD:	YES	Yes	YES	Yes	Yes		NO	No

Note: 1) Individual lift thickness of each mix type will be no less than 3 times nominal maximum aggregate size and no more than 6 times nominal maximum aggregate size, unless otherwise approved by the Engineer.  
2) For design purposes, mixture weight for all mixes is determined to be 112.0 lb/s.y./in., unless otherwise noted.  
3) Sublot sizes for PFP and QCP mixes will be 1000 tons, unless otherwise agreed to by the Engineer and the paving contractor.

MODEL: General notes (Sheet)  
FILE NAME: X:\Projects\Current\1132-1215 IDOT D4 PTB216-036 W03 US 24\DMN\Sheet Files\D468K17-shi-genote.dgn



USER NAME = Cblackery	DESIGNED CB	REVISED -
	DRAWN CB	REVISED -
	CHECKED JG	REVISED -
PLOT DATE = 1/28/2026	DATE -	REVISED -

STATE OF ILLINOIS  
DEPARTMENT OF TRANSPORTATION

### GENERAL NOTES

SCALE: SHEET 1 OF 1 SHEETS STA. TO STA.

F.A.P. RTE.	SECTION	COUNTY	TOTAL SHEETS	SHEET NO.
VAR.	(17, 110, 111)RS-5; 18RS-6	FULTON	52	2
CONTRACT NO. 68K17			ILLINOIS FED. AID PROJECT	

MODEL: I:\Projects\Current\132-1215 IDOT D4 PTB216-036 W03 US 24\DCM\Sheet Files\468K17-sh-SOO.dgn

CODE NO.	ITEM	UNIT	TOTAL QUANTITY	CONSTRUCTION CODE	
				80/20	100
				FED/STATE	STATE
				0005	0047
				ROADWAY	BRIDGE
20200600	EXCAVATING AND GRADING EXISTING SHOULDER	UNIT	790	790	
28100805	STONE DUMPED RIPRAP, CLASS A3	TON	239	239	
40200800	AGGREGATE SURFACE COURSE, TYPE B	TON	51	51	
40600295	POLYMERIZED BITUMINOUS MATERIALS (TACK COAT)	POUND	175290	175290	
40600405	MATERIAL TRANSFER DEVICE	TON	14261	14261	
40600982	HOT-MIX SURFACE REMOVAL - BUTT JOINT	SQ YD	5751	5751	
40600990	TEMPORARY RAMP	SQ YD	296	296	
40603200	POLYMERIZED HOT-MIX ASPHALT BINDER COURSE, 1L 4.75, N50	TON	2894	2894	
40604160	POLYMERIZED HOT-MIX ASPHALT SURFACE COURSE, 1L-9.5, MIX "D", N50	TON	14680	14680	
40800050	INCIDENTAL HOT-MIX ASPHALT SURFACING	TON	411	411	
44000153	HOT-MIX ASPHALT SURFACE REMOVAL, 1"	SQ YD	158941	158941	
44000160	HOT-MIX ASPHALT SURFACE REMOVAL, 2 3/4"	SQ YD	1182	1182	
44003100	MEDIAN REMOVAL	SQ FT	856	856	
44201798	CLASS D PATCHES, TYPE I, 13 INCH	SQ YD	4277	4277	
48102100	AGGREGATE WEDGE SHOULDER, TYPE B	TON	1404	1404	
48203029	HOT-MIX ASPHALT SHOULDERS, 8"	SQ YD	22694	22694	
60622320	CONCRETE MEDIAN, TYPE SM-4.24	SQ FT	156	156	
60622400	CONCRETE MEDIAN, TYPE SM-6.06	SQ FT	700	700	
* 63000001	STEEL PLATE BEAM GUARDRAIL, TYPE A, 6 FOOT POST	FOOT	2950	2950	
* 63100085	TRAFFIC BARRIER TERMINAL, TYPE 6	EACH	10	10	
* 63100087	TRAFFIC BARRIER TERMINAL, TYPE 6A	EACH	1	1	
* 63100167	TRAFFIC BARRIER TERMINAL, TYPE 1 (SPECIAL) TANGENT	EACH	16	16	
* 63100169	TRAFFIC BARRIER TERMINAL, TYPE 1 (SPECIAL) FLARED	EACH	3	3	
63200310	GUARDRAIL REMOVAL	FOOT	6239	6329	
64200108	SHOULDER RUMBLE STRIPS, 8 INCH	FOOT	94915	94915	
64200214	SINUSOIDAL RUMBLE STRIPS, 14"	FOOT	43002	43002	
67000400	ENGINEER'S FIELD OFFICE, TYPE A	CAL MO	7	7	
67100100	MOBILIZATION	L SUM	1	1	
70100450	TRAFFIC CONTROL AND PROTECTION, STANDARD 701201	L SUM	1	1	
70100460	TRAFFIC CONTROL AND PROTECTION, STANDARD 701306	L SUM	1	1	
70107025	CHANGEABLE MESSAGE SIGN	CAL DA	28	28	
70300100	SHORT TERM PAVEMENT MARKING	FOOT	12626	12626	

SPECIALTY ITEM



USER NAME = Cblackerby  
 DESIGNED CB  
 DRAWN CB  
 CHECKED JG  
 PLOT DATE = 1/29/2026

REVISIED -  
 REVISIED -  
 REVISIED -  
 DATE -

STATE OF ILLINOIS  
 DEPARTMENT OF TRANSPORTATION

SUMMARY OF QUANTITIES

SCALE: SHEET 1 OF 2 SHEETS STA. TO STA.

F.A.P. RTE.	SECTION	COUNTY	TOTAL SHEETS	SHEET NO.
VAR.	(17, 110, 111)RS-5; 18RS-6	FULTON	52	3
CONTRACT NO. 68K17				
ILLINOIS FED. AID PROJECT				

MODEL: Unlited-1 [Sheet]  
 FILE NAME: X:\Projects\Current\132-1215 IDOT D4 PTB215-036 W03 US 24\DCN(Sheet Files)\D468K17-sh-SQC.dgn

CODE	NO.	ITEM	UNIT	TOTAL QUANTITY	CONSTRUCTION CODE	
					80/20	100
					FED/STATE	STATE
					0005	0047
					ROADWAY	BRIDGE
70300150		SHORT TERM PAVEMENT MARKING REMOVAL	SQ FT	4209	4209	
70300211		TEMPORARY PAVEMENT MARKING LETTERS AND SYMBOLS - PAINT	SQ FT	111	111	
70300221		TEMPORARY PAVEMENT MARKING - LINE 4" - PAINT	FOOT	52169	52169	
70300241		TEMPORARY PAVEMENT MARKING - LINE 6" - PAINT	FOOT	102564	102564	
70300251		TEMPORARY PAVEMENT MARKING - LINE 8" - PAINT	FOOT	957	957	
70300261		TEMPORARY PAVEMENT MARKING - LINE 12" - PAINT	FOOT	570	570	
70300281		TEMPORARY PAVEMENT MARKING - LINE 24" - PAINT	FOOT	60	60	
* 72000100		SIGN PANEL - TYPE 1	SQ FT	17	17	
* 73000100		WOOD SIGN SUPPORT	FOOT	28	28	
* 78009000		MODIFIED URETHANE PAVEMENT MARKING LETTERS AND SYMBOLS	SQ FT	111	111	
* 78009004		MODIFIED URETHANE PAVEMENT MARKING - LINE 4"	FOOT	52169	52169	
* 78009006		MODIFIED URETHANE PAVEMENT MARKING - LINE 6"	FOOT	102564	102564	
* 78009008		MODIFIED URETHANE PAVEMENT MARKING - LINE 8"	FOOT	957	957	
* 78009012		MODIFIED URETHANE PAVEMENT MARKING - LINE 12"	FOOT	570	570	
* 78009024		MODIFIED URETHANE PAVEMENT MARKING - LINE 24"	FOOT	60	60	
* 78011000		GROOVING FOR RECESSED PAVEMENT MARKING, LETTERS AND SYMBOLS	SQ FT	154	154	
* 78011025		GROOVING FOR RECESSED PAVEMENT MARKING 5"	FOOT	52169	52169	
* 78011035		GROOVING FOR RECESSED PAVEMENT MARKING 7"	FOOT	102564	102564	
* 78011045		GROOVING FOR RECESSED PAVEMENT MARKING 9"	FOOT	957	957	
* 78011065		GROOVING FOR RECESSED PAVEMENT MARKING 13"	FOOT	570	570	
* 78011125		GROOVING FOR RECESSED PAVEMENT MARKING 25"	FOOT	60	60	
* 78100100		RAISED REFLECTIVE PAVEMENT MARKER	EACH	766	766	
		RAISED REFLECTIVE PAVEMENT MARKER REMOVAL	EACH	766	766	
		GUARDRAIL AGGREGATE EROSION CONTROL	TON	390	390	
		CONSTRUCTION LAYOUT	L SUM	1	1	
		EROSION CONTROL CURB REMOVAL	FOOT	1867	1867	
		RUMBLE STRIP	SQ YD	117	117	
		STRIP SEAL GLAND REPLACEMENT	FOOT	40		40
		HOT-MIX ASPHALT SURFACE REMOVAL, SPECIAL	SQ YD	3005	3005	
		CLEANING DRAINAGE SYSTEM	L SUM	1		1
		LINEAR DELINEATOR PANELS, 4 INCH	EACH	70	70	
Ø	Ø 0042	Ø Z0076600	Ø TRAINÉES	Ø HOUR	Ø 2,000	Ø 2,000
		Ø XZ013798	Ø CONSTRUCTION STATION LAYOUT	Ø L SUM	Ø 1	Ø 1
		Ø Z0076604	Ø TRAINÉES - TRAINING PROGRAM GRADUATE	Ø HOUR	Ø 2,000	Ø 2,000

\* SPECIALTY ITEM

Ø 0042

Ø  
Ø



USER NAME = Cblackery  
 PLOT DATE = 1/29/2026

DESIGNED CB  
 DRAWN CB  
 CHECKED JG  
 DATE -

REVISED -  
 REVISED -  
 REVISED -  
 REVISED -

STATE OF ILLINOIS  
 DEPARTMENT OF TRANSPORTATION

SUMMARY OF QUANTITIES

SCALE: SHEET 2 OF 2 SHEETS STA. TO STA.

F.A.P. RTE.	SECTION	COUNTY	TOTAL SHEETS	SHEET NO.
VAR	(17, 110, 111)RS-5; 18RS-6	FULTON	52	4
CONTRACT NO. 68K17				
ILLINOIS   FED. AID PROJECT				

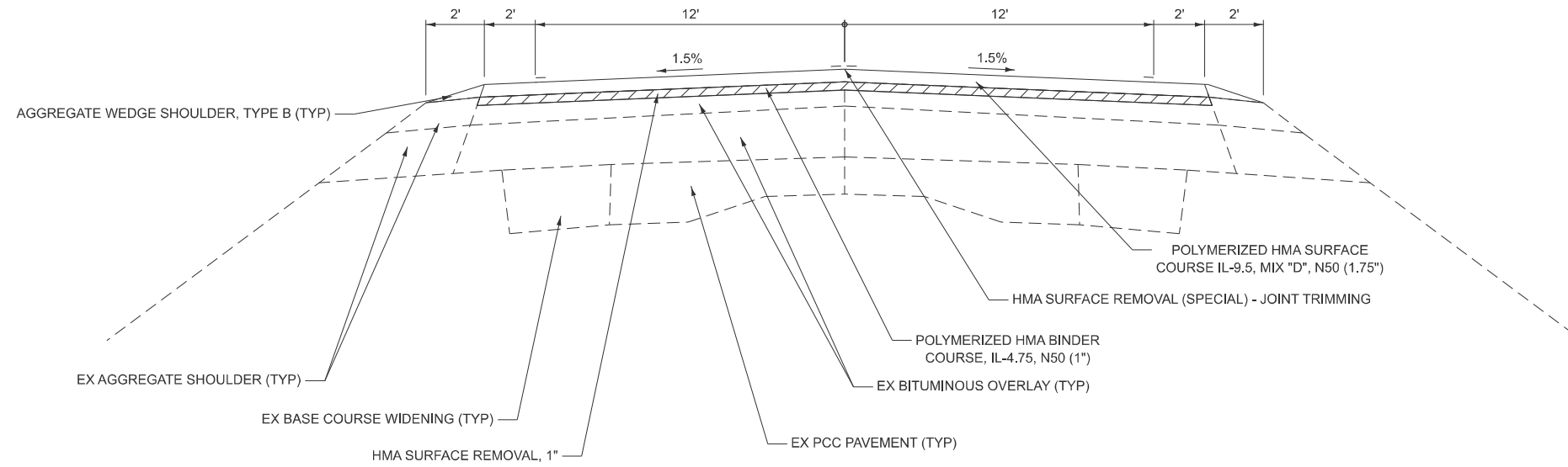

**PROPOSED TYPICAL SECTION**

STA. 0+00 TO STA. 30+00  
 STA. 111+86 TO STA. 132+00

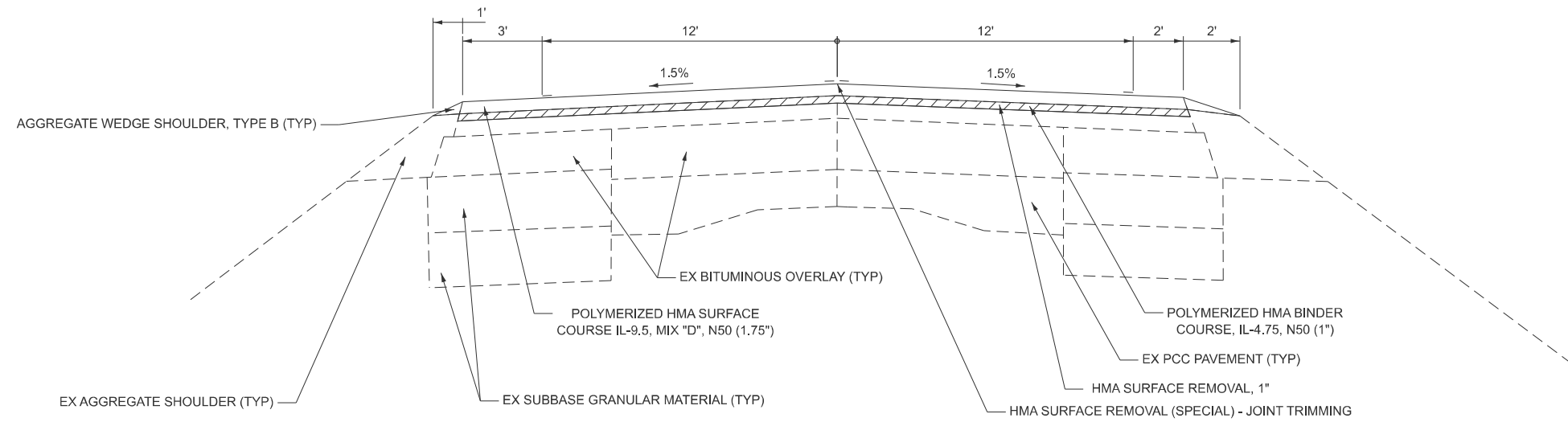

**PROPOSED TYPICAL SECTION**

STA. 97+60(LT) & STA. 96+00(RT) TO STA. 111+86

MODEL: TYP\_1 (Sheet)  
 FILE NAME: X:\Projects\Current\132-1215 IDOT D4 PTB216-036 W03 US 24\DWG\Sheet Files\68K17-sh-typical.dgn



USER NAME = Cblackery	DESIGNED CB	REVISIONS
	DRAWN CB	REVISIONS
	CHECKED JG	REVISIONS
PLOT DATE = 1/28/2026	DATE -	REVISIONS

**STATE OF ILLINOIS  
 DEPARTMENT OF TRANSPORTATION**

**TYPICAL SECTIONS**

SCALE: SHEET 1 OF 9 SHEETS STA. TO STA.

F.A.P. RTE.	SECTION	COUNTY	TOTAL SHEETS	SHEET NO.
VAR.	(17, 110, 111)RS-5; 18RS-6	FULTON	52	5
CONTRACT NO. 68K17				
ILLINOIS FED. AID PROJECT				

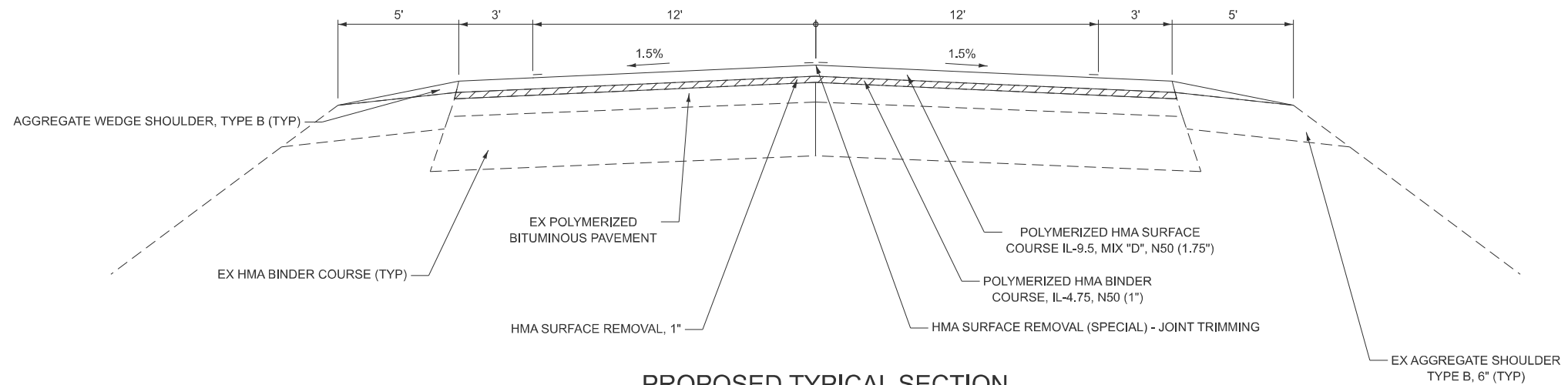

**PROPOSED TYPICAL SECTION**

STA. 30+00 TO STA. 32+80.28  
 STA 41+48.15 TO STA. 59+59.68

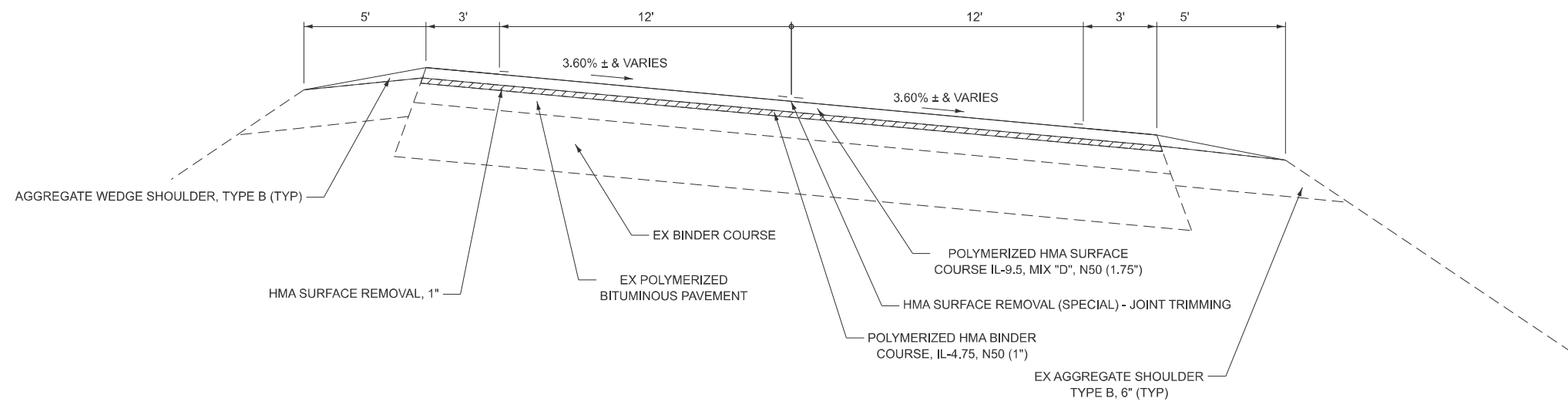

**PROPOSED TYPICAL SECTION**

STA. 32+80.28 TO STA. 41+48.15

MODEL: TYP 2 (Sheet)  
 FILE NAME: X:\Projects\Current\132-1215 IDOT D4 PTB216-036.W03 US 24\Drawn\Sheet Files\0468K17-sh-typical.dgn



USER NAME = Cblackery	DESIGNED CB	REVISD -
	DRAWN CB	REVISD -
	CHECKED JG	REVISD -
PLOT DATE = 1/29/2026	DATE -	REVISD -

DESIGNED CB	REVISD -
DRAWN CB	REVISD -
CHECKED JG	REVISD -
DATE -	REVISD -

**STATE OF ILLINOIS  
 DEPARTMENT OF TRANSPORTATION**

**TYPICAL SECTIONS**

SCALE: SHEET 2 OF 9 SHEETS STA. TO STA.

F.A.P. RTE.	SECTION	COUNTY	TOTAL SHEETS	SHEET NO.
VAR.	(17, 110, 111)RS-5; 18RS-6	FULTON	52	6
CONTRACT NO. 68K17				
ILLINOIS FED. AID PROJECT				

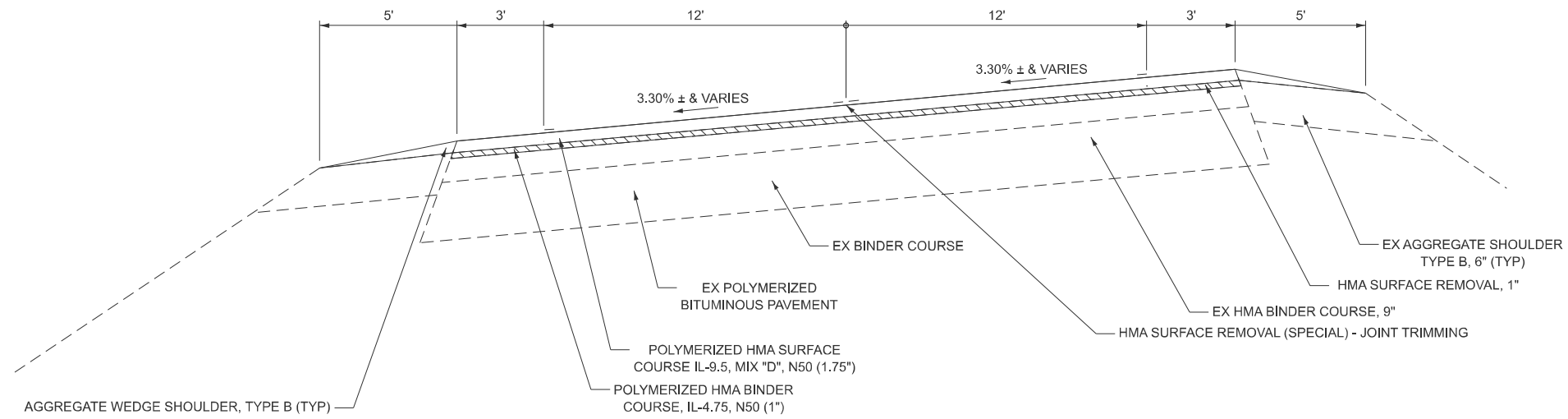

**PROPOSED TYPICAL SECTION**

STA 59+59.68 TO STA 60+88(RT) & 63+57(LT)

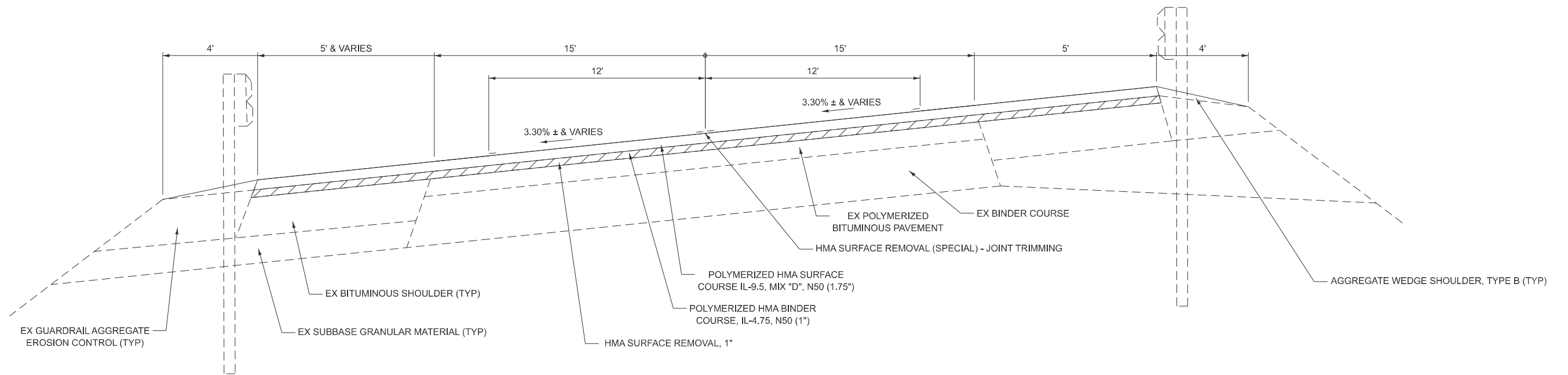

**PROPOSED TYPICAL SECTION**

STA. 60+88(RT) & STA. 63+57(LT) TO STA. 64+27.41  
STA. 65+80.21 TO STA. 70+21

MODEL: TYP 3 (Sheet)  
FILE NAME: X:\Projects\Current\132-1215 IDOT D4 PTB216-036 W03 US 24\Drawings\Sheet Files\68K17-sh-typical.dgn



USER NAME = Cblackery	DESIGNED CB	REVISED -
	DRAWN CB	REVISED -
	CHECKED JG	REVISED -
PLOT DATE = 1/29/2026	DATE -	REVISED -

**STATE OF ILLINOIS  
DEPARTMENT OF TRANSPORTATION**

**TYPICAL SECTIONS**

SCALE: SHEET 3 OF 9 SHEETS STA. TO STA.

F.A.P. RTE.	SECTION	COUNTY	TOTAL SHEETS	SHEET NO.
VAR.	(17, 110, 111)RS-5; 18RS-6	FULTON	52	7
CONTRACT NO. 68K17				
ILLINOIS FED. AID PROJECT				

MODEL: TYP 4 (Sheet)  
 FILE NAME: X:\Projects\Current\132-1215 IDOT D4 PTB216-036 I\03 US 24\IDGN\Sheet Files\0468K17-sh-typical.dgn

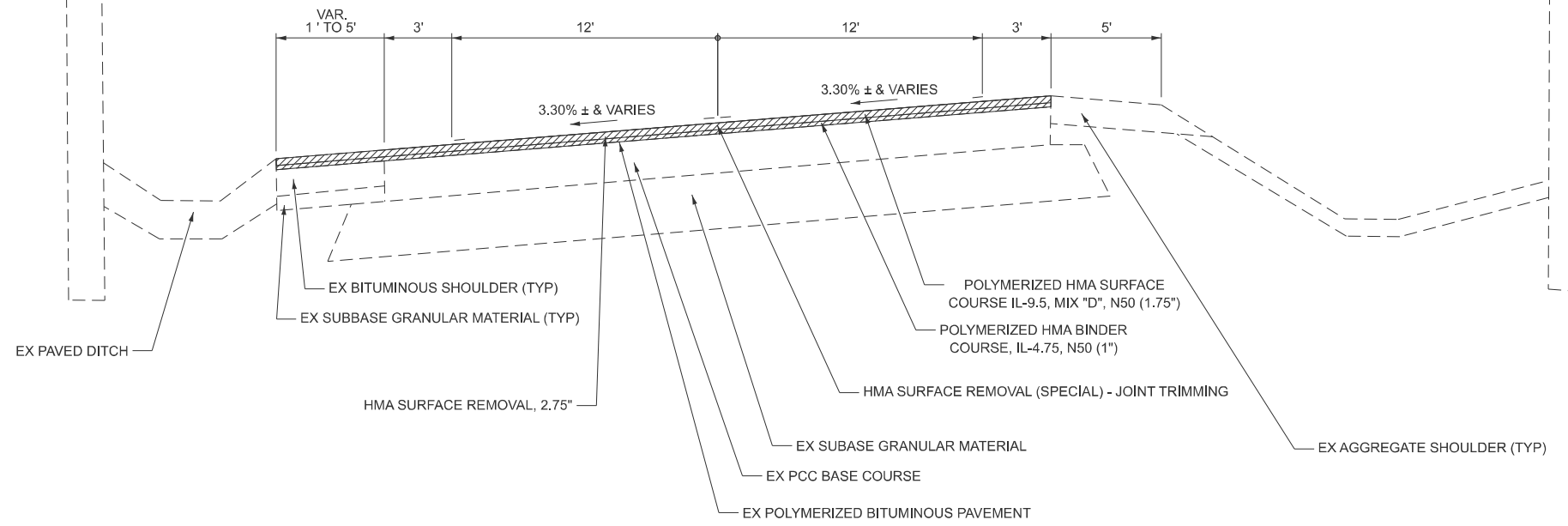

**PROPOSED TYPICAL SECTION**  
 STA. 78+01 TO STA. 81+90(LT) & STA. 82+10(RT)

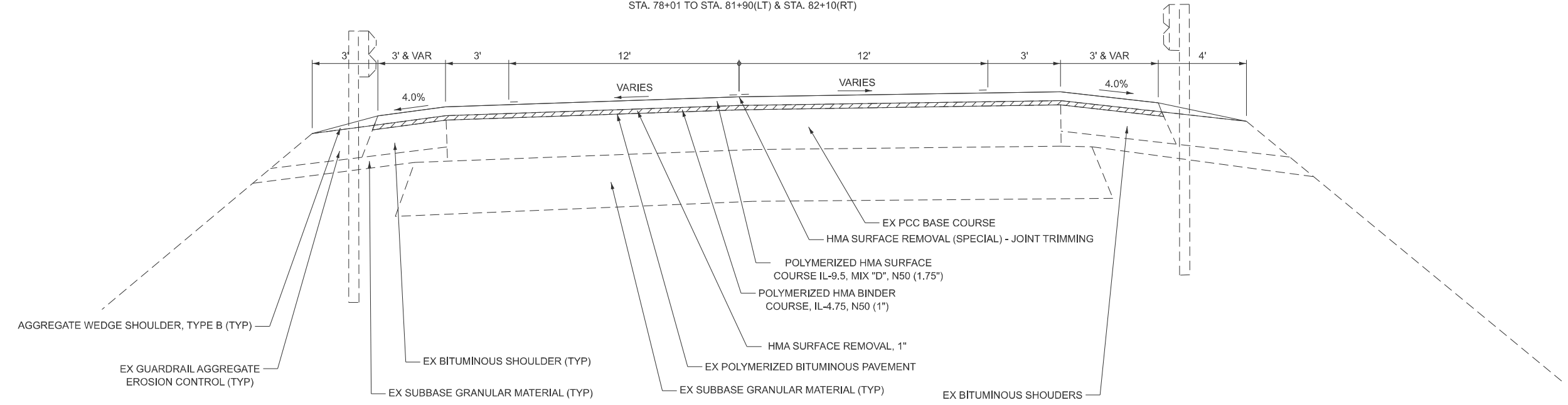

**PROPOSED TYPICAL SECTION**  
 STA. 81+90(LT) & STA. 82+10(RT) TO STA. 83+61



USER NAME = Cblackery	DESIGNED CB	REVISED -
	DRAWN CB	REVISED -
	CHECKED JG	REVISED -
PLOT DATE = 1/29/2026	DATE -	REVISED -

**STATE OF ILLINOIS**  
**DEPARTMENT OF TRANSPORTATION**

**TYPICAL SECTIONS**

SCALE: SHEET 4 OF 9 SHEETS STA. TO STA.

F.A.P. RTE.	SECTION	COUNTY	TOTAL SHEETS	SHEET NO.
VAR.	(17, 110, 111)RS-5; 18RS-6	FULTON	52	8
CONTRACT NO. 68K17				
ILLINOIS FED. AID PROJECT				

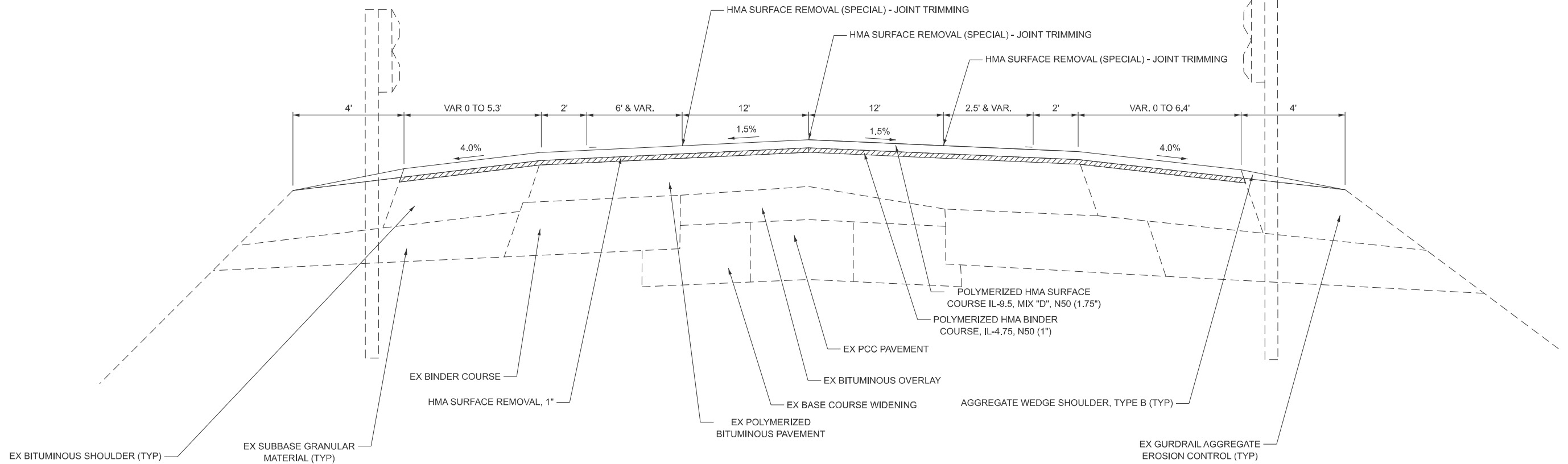

**PROPOSED TYPICAL SECTION**

STA. 85+29(LT) TO 88+21(LT)  
 STA. 85+29(RT) TO 86+27(RT)

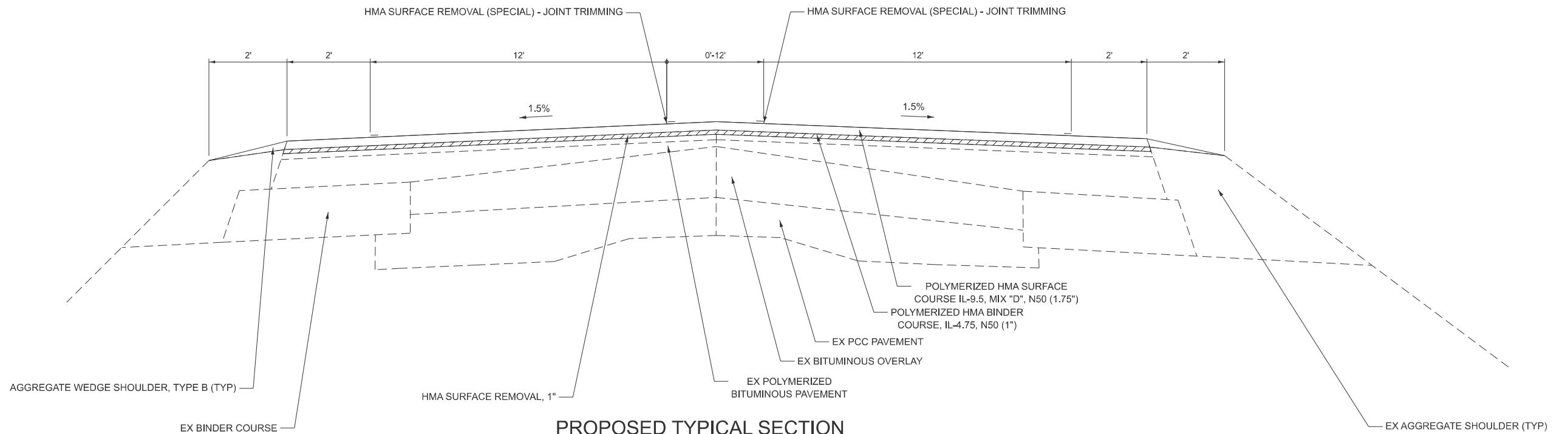

**PROPOSED TYPICAL SECTION**

STA. 88+21(LT) TO STA. 97+60(LT)  
 STA. 86+27(RT) TO STA. 96+00(RT)

MODEL: TYP 5 (Sheet)  
 FILE NAME: X:\Projects\Current\132-1215 IDOT D4 PTB216-036 I\03 US 24\Drawings\Sheet Files\0468K17-sh-typical.dgn



USER NAME = Cblackery	DESIGNED CB
	DRAWN CB
	CHECKED JG
PLOT DATE = 1/29/2026	DATE -

REVISION	DATE	BY
REVIS		
REVIS		
REVIS		
REVIS		

DESIGNED	REVISION
DRAWN	REVISION
CHECKED	REVISION
DATE	REVISION

**STATE OF ILLINOIS  
 DEPARTMENT OF TRANSPORTATION**

**TYPICAL SECTIONS**

SCALE: SHEET 5 OF 9 SHEETS STA. TO STA.

F.A.P. RTE.	SECTION	COUNTY	TOTAL SHEETS	SHEET NO.
VAR.	(17, 111, 110)RS-5; 18RS-6	FULTON	52	9
CONTRACT NO. 68K17				
ILLINOIS FED. AID PROJECT				

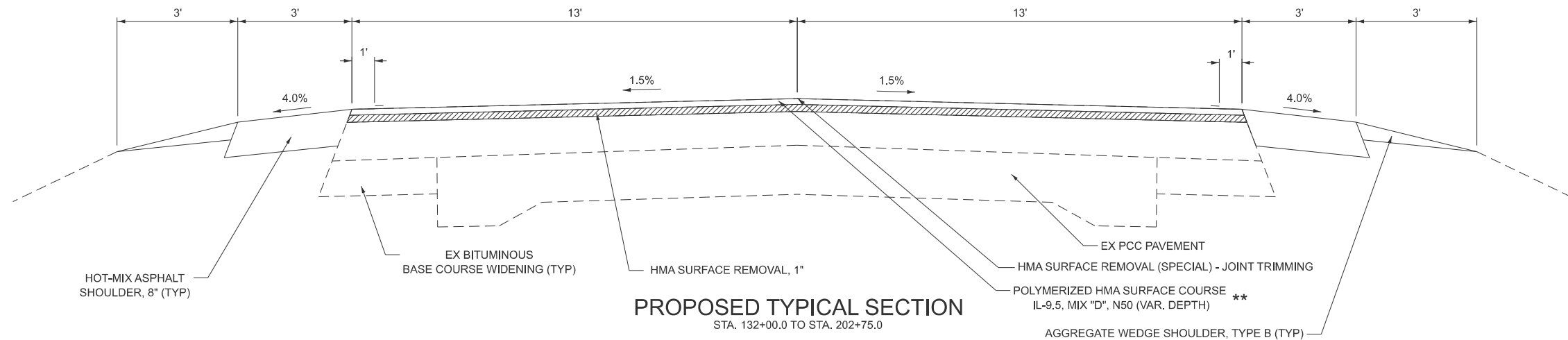

**PROPOSED TYPICAL SECTION**  
STA. 132+00.0 TO STA. 202+75.0

\*\* STA. 202+59.10 TO STA. 202+84.14 TRANSITION FROM SMART OVERLAY (1.5") TO STANDARD OVERLAY (2.75")

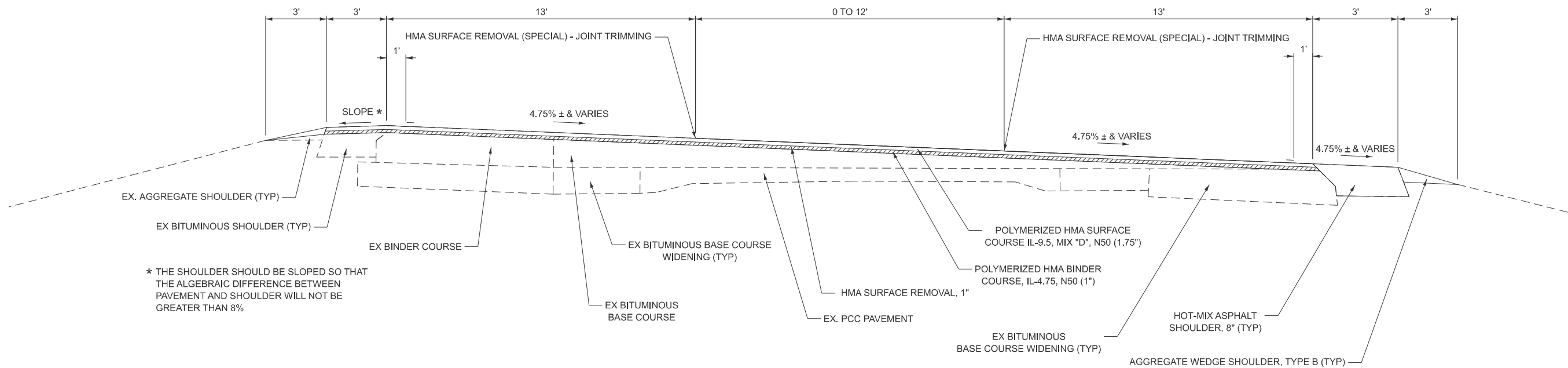

**PROPOSED TYPICAL SECTION**  
STA. 202+75.0 TO STA. 209+07.0

\* THE SHOULDER SHOULD BE SLOPED SO THAT THE ALGEBRAIC DIFFERENCE BETWEEN PAVEMENT AND SHOULDER WILL NOT BE GREATER THAN 8%

MODEL: TYP 6 (Sheet) FILE NAME: X:\Projects\Current\132-1215 IDOT D4 PTB216-036.W03 US 24\DWG\Sheet Files\132-1215-036-TYPICAL.dgn



USER NAME = Cblackery	DESIGNED CB	REVISED -
	DRAWN CB	REVISED -
	CHECKED JG	REVISED -
PLOT DATE = 1/29/2026	DATE -	REVISED -

**STATE OF ILLINOIS  
DEPARTMENT OF TRANSPORTATION**

**TYPICAL SECTIONS**

SCALE: SHEET 6 OF 9 SHEETS STA. TO STA.

F.A.P. RTE.	SECTION	COUNTY	TOTAL SHEETS	SHEET NO.
VAR.	(17, 110, 111)RS-5; 18RS-6	FULTON	52	10
CONTRACT NO. 68K17				
ILLINOIS FED. AID PROJECT				

MODEL: TYP 7 (Sheet)  
 FILE NAME: X:\Projects\Current\132-1215 IDOT D4 PTB216-036 W03 US 24\DWG\Sheet Files\D468K17-sh1-typical.dgn

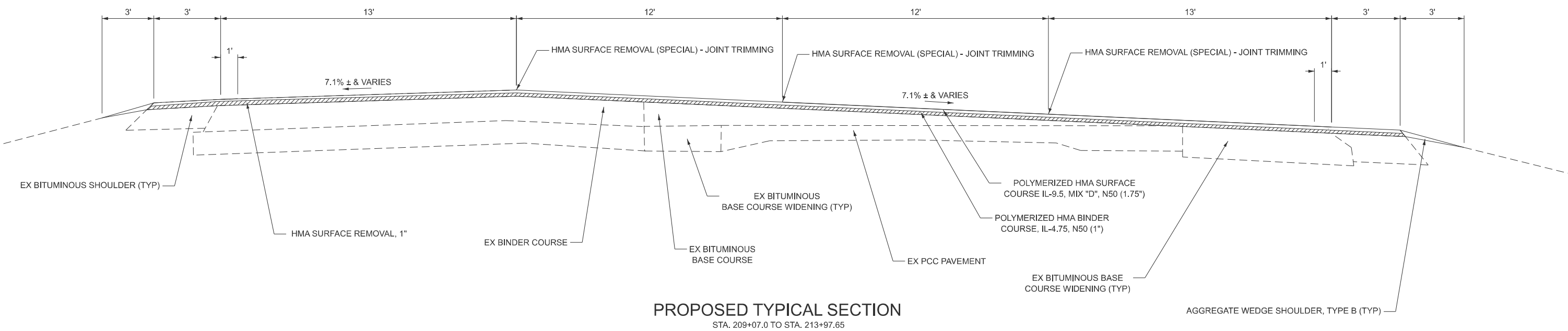

**PROPOSED TYPICAL SECTION**  
 STA. 209+07.0 TO STA. 213+97.65

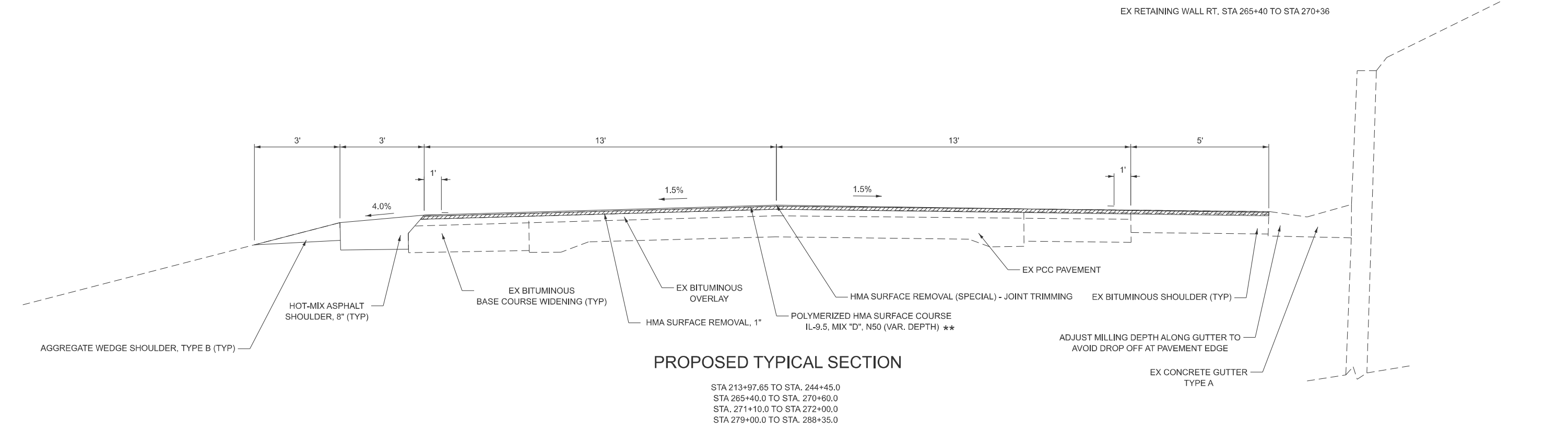

**PROPOSED TYPICAL SECTION**  
 STA. 213+97.65 TO STA. 244+45.0  
 STA. 265+40.0 TO STA. 270+60.0  
 STA. 271+10.0 TO STA. 272+00.0  
 STA. 279+00.0 TO STA. 288+35.0

\*\* STA. 214+94.41 TO STA. 215+19.41 TRANSITION FROM STANDARD OVERLAY (2.75") TO SMART OVERLAY (1.5")



USER NAME = Cblackerby	DESIGNED CB	REVISED -
	DRAWN CB	REVISED -
	CHECKED JG	REVISED -
PLOT DATE = 1/29/2026	DATE -	REVISED -

**STATE OF ILLINOIS**  
**DEPARTMENT OF TRANSPORTATION**

SCALE: SHEET 7 OF 9 SHEETS STA. TO STA.

**TYPICAL SECTIONS**

F.A.P. RTE.	SECTION	COUNTY	TOTAL SHEETS	SHEET NO.
VAR.	(17, 110, 111)RS-5; 15RS-6	FULTON	52	11
CONTRACT NO. 68K17				
ILLINOIS FED. AID PROJECT				

MODEL: TYP 8 (Sheet)  
 FILE NAME: X:\Projects\Current\132-1215 IDOT D4 PTB216-036.W03 US 24\DWG\Sheet Files\468K17-sh-typical.dgn

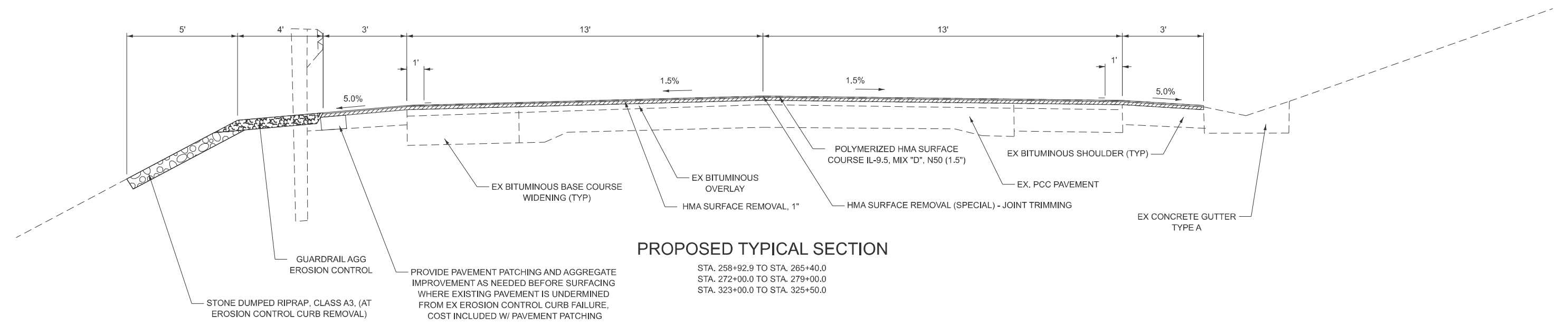

**PROPOSED TYPICAL SECTION**

STA. 258+92.9 TO STA. 265+40.0  
 STA. 272+00.0 TO STA. 279+00.0  
 STA. 323+00.0 TO STA. 325+50.0

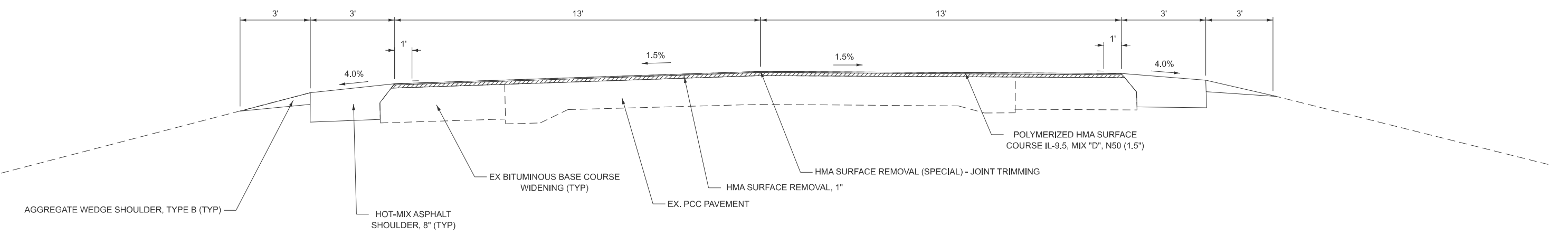

**PROPOSED TYPICAL SECTION**

STA. 244+45.0 TO STA 255+73.57  
 STA. 270+60.0 TO STA. 271+10.0  
 STA. 288+35.0 TO STA. 323+00.0  
 STA 325+50.0 TO STA. 387+18.33  
 STA 449+00.82 TO STA. 486+18.81



USER NAME = Cblackerby	DESIGNED CB	REVISED -
	DRAWN CB	REVISED -
	CHECKED JG	REVISED -
PLOT DATE = 1/29/2026	DATE -	REVISED -

**STATE OF ILLINOIS  
 DEPARTMENT OF TRANSPORTATION**

**TYPICAL SECTIONS**

SCALE: SHEET 8 OF 9 SHEETS STA. TO STA.

F.A.P. RTE.	SECTION	COUNTY	TOTAL SHEETS	SHEET NO.
VAR.	(17, 110, 111)RS-5; 18RS-6	FULTON	52	12
CONTRACT NO. 68K17				
ILLINOIS FED. AID PROJECT				

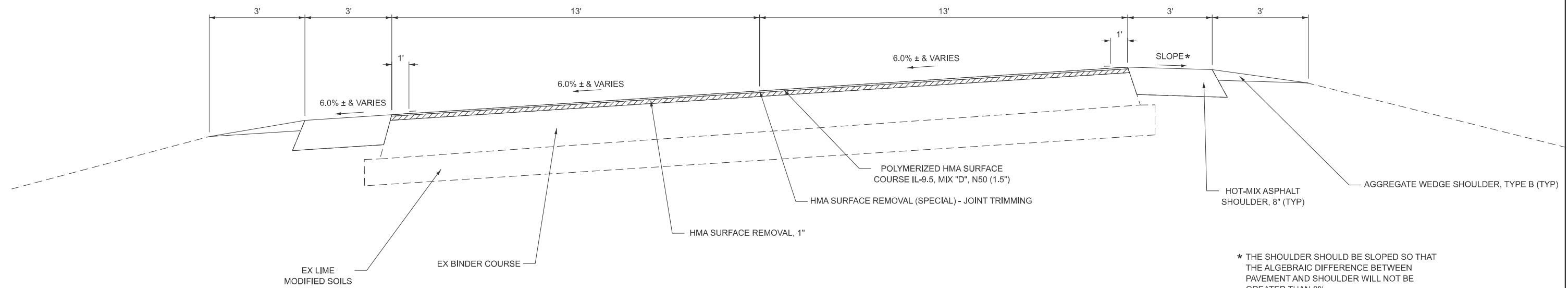

**PROPOSED TYPICAL SECTION**

STA. 486+18.81 TO STA. 514+96.62

\* THE SHOULDER SHOULD BE SLOPED SO THAT THE ALGEBRAIC DIFFERENCE BETWEEN PAVEMENT AND SHOULDER WILL NOT BE GREATER THAN 8%

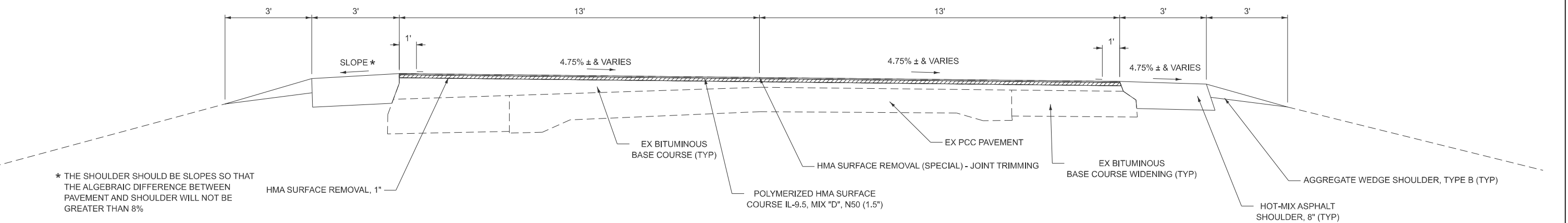

**PROPOSED TYPICAL SECTION**

STA. 387+18.33 TO STA. 449+00.82  
STA. 514+96.62 TO STA. 663+60.76

\* THE SHOULDER SHOULD BE SLOPED SO THAT THE ALGEBRAIC DIFFERENCE BETWEEN PAVEMENT AND SHOULDER WILL NOT BE GREATER THAN 8%

MODEL: TYP 9 (Sheet)  
FILE NAME: X:\Projects\Current\132-1215 IDOT D4 PTB216-036 I\03 US 24\Drawn\Sheet Files\0468K17-sh-typical.dgn



USER NAME = Cblackerby	DESIGNED CB	REVISED -
	DRAWN CB	REVISED -
	CHECKED JG	REVISED -
PLOT DATE = 1/29/2026	DATE -	REVISED -

**STATE OF ILLINOIS  
DEPARTMENT OF TRANSPORTATION**

**TYPICAL SECTIONS**

SCALE: SHEET 9 OF 9 SHEETS STA. TO STA.

F.A.P. RTE.	SECTION	COUNTY	TOTAL SHEETS	SHEET NO.
VAR.	(17, 110, 111)RS-5; 18RS-6	FULTON	52	13
CONTRACT NO. 68K17				
ILLINOIS FED. AID PROJECT				

MAINLINE RESURFACING SCHEDULE												
LOCATION		WIDTH	LENGTH	AREA	HOT- MIX ASPHALT SURFACE REMOVAL, 1"	HOT- MIX ASPHALT SURFACE REMOVAL, 2.75"	POLYMERIZED BITUMINOUS MATERIALS (TACK COAT)	POLYMERIZED HMA BINDER COURSE, IL 4.75, N50	POLYMERIZED HMA SURFACE COURSE, IL 9.5, MIX D, N50	HOT-MIX ASPHALT SURFACE REMOVAL - BUTT JOINT	TEMPORARY RAMP	MATERIAL TRANSFER DEVICE
STATION TO STATION		FOOT	FOOT	SQ FT	SQ YD	SQ YD	POUND	TON	TON	SQ YD	SQ YD	TON
+ .0	+35.0	24.0	35.0	840.0	-	-	135	6	10	104	19	16
+35.0	63+90.5	24.0	6355.5	152532.0	16948	-	24406	950	1661	-	-	2611
63+90.5	64+27.4	24.0	36.9	885.6	-	-	142	6	10	164	26	16
BRIDGE OMISSION												
65+80.2	66+12.3	24.0	32.1	770.4	-	-	124	5	9	146	32	14
66+12.3	69+90.5	24.0	378.2	9076.8	1009	-	1453	57	99	-	-	156
69+90.5	70+25.4	24.0	34.9	837.6	-	-	135	6	10	155	27	16
BRIDGE OMISSION												
78+01.3	78+36.3	24.0	35.0	840.0	-	-	135	6	10	162	29	16
78+36.3	79+13.4	24.0	77.1	1851.1	206	-	297	12	21	-	-	33
79+13.4	82+24.0	24.0	310.6	7454.4	-	829	1193	47	82	-	-	129
82+24.0	83+25.7	24.0	101.7	2440.8	272	-	391	16	27	-	-	43
83+25.7	83+60.8	24.0	35.1	841.7	-	-	135	6	10	145	25	16
BRIDGE OMISSION												
STATION EQUATION												
BRIDGE OMISSION												
85+29.7	85+64.7	VARIES	35.0	859.3	-	-	138	6	10	146	25	16
85+64.7	94+67.9	VARIES	903.2	28109.5	3124	-	4498	175	307	-	-	482
94+67.9	132+25.0	24.0	3757.1	90170.4	10019	-	14428	562	982	-	-	1544
132+25.0	202+59.1	24.0	7034.1	168818.4	18758	-	13506	-	1576	-	-	1576
202+59.1	215+19.4	VARIES	1260.3	40054.4	4451	-	6409	250	437	-	-	687
215+19.4	227+43.8	24.0	1224.4	29385.6	3266	-	2351	-	275	-	-	275
227+43.8	228+15.8	24.0	72.0	1728.0	192	-	139	-	17	-	-	17
228+15.8	232+29.9	24.0	414.1	9938.4	1105	-	796	-	93	-	-	93
232+29.9	253+99.8	24.0	2169.9	52077.6	5787	-	4167	-	487	-	-	487
253+99.8	254+18.6	24.0	18.8	451.2	51	-	37	-	5	-	-	5
254+18.6	255+43.3	24.0	124.7	2992.8	333	-	240	-	28	-	-	28
255+43.3	255+73.6	24.0	30.3	727.2	-	-	59	-	7	111	30	7
BRIDGE OMISSION												
258+92.9	259+22.5	24.0	29.6	710.4	-	-	57	-	7	101	28	7
259+22.5	270+54.1	24.0	1131.6	27157.9	3018	-	2173	-	254	-	-	254
270+54.1	274+73.1	24.0	419.0	10056.5	-	-	805	-	94	-	-	94
STATION EQUATION												
275+06.7	280+13.7	24.0	507.0	12168.0	1352	-	974	-	114	-	-	114
280+13.7	288+27.2	24.0	813.5	19524.0	2170	-	1562	-	183	-	-	183
288+07.2	477+60.5	24.0	18953.3	454879.2	50543	-	36391	-	4246	-	-	4246
STATION EQUATION												
477+40.8	514+96.6	24.0	3755.8	90139.2	10016	-	7212	-	842	-	-	842
514+96.6	663+30.8	24.0	1029.6	24710.4	2746	-	1977	-	231	-	-	231
663+30.8	663+60.8	24.0	30.0	720.0	-	-	58	-	7	104	18	7
SIDEROADS												
US 136/ IL 100		VARIES		24530.9	2726	-	3925	153	268	88	17	-
US 136		VARIES		14678.5	1631	-	2349	92	160	117	20	-
TOTALS					139723	829	132797	2355	12579	1543	296	14261

MODEL: Untitled (Sheet)  
 FILE NAME: X:\Projects\Current\132-1215 IDOT D4 PTB216-036 W03 US 24\DWG\Sheet Files\0468K17-sh-schedule.dgn



USER NAME = Cblackery	DESIGNED CB	REVISED -
	DRAWN CB	REVISED -
	CHECKED JG	REVISED -
PLOT DATE = 1/28/2026	DATE -	REVISED -

**STATE OF ILLINOIS  
DEPARTMENT OF TRANSPORTATION**

**SCHEDULE OF QUANTITIES**

SCALE: SHEET 1 OF 5 SHEETS STA. TO STA.

F.A.P. RTE.	SECTION	COUNTY	TOTAL SHEETS	SHEET NO.
VAR.	(17, 110, 111)RS-5; 18RS-6	FULTON	52	14
CONTRACT NO. 68K17				
ILLINOIS FED. AID PROJECT				

PAVEMENT MARKING SCHEDULE

LOCATION	LENGTH	CENTERLINE CONFIGURATION	LENGTH OF EDGELINE (RT)	LENGTH OF EDGELINE (LT)	MODIFIED URETHANE PAVEMENT MARKING - LINE 6" (WHITE EDGELINE)	GROOVING FOR RECESSED PAVEMENT MARKING - 7"	MODIFIED URETHANE PAVEMENT MARKING - LINE 4" (YELLOW)	GROOVING FOR RECESSED PAVEMENT MARKING - 5"	MODIFIED URETHANE PAVEMENT MARKING - LINE 8" (WHITE)	GROOVING FOR RECESSED PAVEMENT MARKING - 9"	MODIFIED URETHANE PAVEMENT MARKING - LINE 12" (YELLOW)	MODIFIED URETHANE PAVEMENT MARKING - LINE 12" (WHITE)	GROOVING FOR RECESSED PAVEMENT MARKING - 13"	MODIFIED URETHANE PAVEMENT MARKING - LINE 24" (WHITE)	GROOVING FOR RECESSED PAVEMENT MARKING - 25"	MODIFIED URETHANE PAVEMENT MARKING - LETTERS AND SYMBOLS (WHITE)	GROOVING FOR RECESSED PAVEMENT MARKING - LETTERS AND SYMBOLS	RAISED REFLECTIVE PAVEMENT MARKER	RAISED REFLECTIVE PAVEMENT MARKER REMOVAL	TEMPORARY PAVEMENT MARKING - LINE 4" - PAINT	TEMPORARY PAVEMENT MARKING - LINE 6" - PAINT	TEMPORARY PAVEMENT MARKING - LINE 8" - PAINT	TEMPORARY PAVEMENT MARKING - LINE 12" - PAINT	TEMPORARY PAVEMENT MARKING - LINE 24" - PAINT	TEMPORARY PAVEMENT MARKING - LETTERS AND SYMBOLS - PAINT
STATION TO STATION	FOOT		FOOT	FOOT	FOOT	FOOT	FOOT	FOOT	FOOT	FOOT	FOOT	FOOT	FOOT	FOOT	FOOT	SQ FT	SQ FT	EACH	EACH	FOOT	FOOT	FOOT	FOOT	FOOT	SQ FT
+ .0	2+78.2	278.2	DNPZ/SKIPDASH	278	278	557	557	348	348	-	-	-	-	-	-	-	-	4	4	348	557	-	-	-	-
2+70.2	7+01.0	422.0	DNPZ	423	423	846	846	846	846	-	-	-	-	-	-	-	-	6	6	846	846	-	-	-	-
7+01.0	17+40.0	1039.0	DNPZ/SKIPDASH	1039	1039	2078	2078	1299	1299	-	-	-	-	-	-	-	-	13	13	1299	2078	-	-	-	-
17+40.0	28+55.8	1115.8	SKIPDASH	1116	1072	2188	2188	279	279	-	-	-	-	-	-	-	-	14	14	279	2188	-	-	-	-
28+55.8	30+50.0	194.2	DNPZ/SKIPDASH	194	194	389	389	243	243	-	-	-	-	-	-	-	-	3	3	243	389	-	-	-	-
30+50.0	41+48.2	1098.2	DNPZ	1098	1098	2197	2197	2197	2197	-	-	-	-	-	-	-	-	14	14	2197	2197	-	-	-	-
41+48.2	46+00.0	451.8	DNPZ/SKIPDASH	452	452	904	904	565	565	-	-	-	-	-	-	-	-	6	6	565	904	-	-	-	-
46+00.0	64+27.4	1827.4	SKIPDASH	1827	1827	3655	3655	457	457	-	-	-	-	-	-	-	-	23	23	457	3655	-	-	-	-
BRIDGE OMISSION																									
65+80.2	70+00.0	419.8	SKIPDASH	420	420	840	840	105	105	-	-	-	-	-	-	-	-	6	6	105	840	-	-	-	-
70+00.0	70+25.4	25.4	DNPZ	25	25	51	51	51	51	-	-	-	-	-	-	-	-	1	1	51	51	-	-	-	-
BRIDGE OMISSION																									
78+01.3	83+60.8	559.5	DNPZ	494	491	986	986	1119	1119	-	-	-	-	-	-	-	-	7	7	1119	986	-	-	-	-
BRIDGE OMISSION																									
STATION EQUATION																									
BRIDGE OMISSION																									
85+29.8	88+32.5	302.66	MED.	215.80	300.00	516	516	1211	1211	-	-	70	-	70	-	-	-	18	18	1211	516	-	70	-	-
88+32.5	89+87.8	155.29	LTL.	16.50	158.00	175	175	230	230	115	115	-	-	-	-	-	-	10	10	230	175	115	-	-	32
89+87.8	94+67.9	480.10	MED.	480.10	480.10	961	961	1921	1921	-	-	83	-	83	-	-	-	24	24	1921	961	-	83	-	-
94+67.9	99+67.8	500.00	DNPZ	500.00	500.00	1000	1000	1000	1000	-	-	-	-	-	-	-	-	7	7	1000	1000	-	-	-	-
99+67.8	111+73.2	1205.40	DNPZ	1205.40	1205.40	2411	2411	2411	2411	-	-	-	-	-	-	-	-	16	16	2411	2411	-	-	-	-
111+73.2	122+00.0	1026.80	DNPZ/SKIPDASH	1026.80	1026.80	2054	2054	1284	1284	-	-	-	-	-	-	-	-	13	13	1284	2054	-	-	-	-
122+00.0	163+22.5	4122.50	SKIPDASH	4038.50	4038.50	8077	8077	1031	1031	-	-	-	-	-	-	-	-	52	52	1031	8077	-	-	-	-
163+22.5	183+40.2	2017.70	DNPZ/SKIPDASH	2017.70	2017.70	4036	4036	2523	2523	-	-	-	-	-	-	-	-	26	26	2523	4036	-	-	-	-
183+40.2	197+75.8	1435.55	SKIPDASH	1435.55	1435.55	2872	2872	359	359	-	-	-	-	-	-	-	-	18	18	359.0	2872	-	-	-	-
197+75.8	202+75.0	499.26	DNPZ	499.26	499.26	999	999	999	999	-	-	-	-	-	-	-	-	7	7	999.0	999	-	-	-	-
202+75.0	206+67.3	392.30	MED.	392.30	392.30	785	785	1570	1570	-	-	94	-	94	-	-	-	18	18	1570	785	-	94	-	-
206+67.3	208+75.0	207.70	LTL	80.00	163.00	243	243	415	415	173	173	-	-	-	-	-	-	17	17	415	243	173	-	-	47
208+75.0	209+89.9	114.90	LTL	35.00	-	35	35	120	120	60	60	-	-	-	-	-	-	7	7	120	35	60	-	-	32
209+89.9	211+99.9	210.00	MED.	-	210.00	210	210	840	840	-	-	62	-	62	-	-	-	18	18	840	210	-	62	-	-
211+99.9	213+11.7	111.80	DNPZ	111.80	111.80	224	224	224	224	-	-	-	-	-	-	-	-	2	2	224	224	-	-	-	-
213+11.7	218+00.0	488.30	DNPZ	488.30	488.30	977	977	977	977	-	-	-	-	-	-	-	-	7	7	977	977	-	-	-	-
218+00.0	227+96.9	996.90	DNPZ/SKIPDASH	996.90	996.90	1994	1994	1247	1247	-	-	-	-	-	-	-	-	13	13	1247	1994	-	-	-	-
227+96.9	255+73.6	2776.70	SKIPDASH	2776.70	2776.70	5554	5554	695	695	-	-	-	-	-	-	-	-	35	35	695	5554	-	-	-	-
BRIDGE OMISSION																									
258+92.9	259+22.5	29.6	SKIPDASH	30	30	60	60	8	8	-	-	-	-	-	-	-	-	1	1	8	60	-	-	-	-
259+22.5	269+00.0	977.50	DNPZ/SKIPDASH	978	978	1955	1955	1222	1222	-	-	-	-	-	-	-	-	13	13	1222	1955	-	-	-	-
269+00.0	271+00.0	200.00	DNPZ	200	200	400	400	400	400	-	-	-	-	-	-	-	-	3	3	400	400	-	-	-	-
271+00.0	274+73.1	373.10	DNPZ/SKIPDASH	373	373	747	747	467	467	-	-	-	-	-	-	-	-	5	5	467	747	-	-	-	-
STATION EQUATION																									
275+06.7	282+19.8	713.14	DNPZ/SKIPDASH	608	633	1242	1242	892	892	-	-	-	-	-	-	-	-	9	9	892	1242	-	-	-	-
282+19.8	307+76.8	2557.00	SKIPDASH	2557	2557	5114	5114	640	640	-	-	-	-	-	-	-	-	32	32	640	5114	-	-	-	-
307+76.8	315+91.4	814.60	DNPZ/SKIPDASH	815	815	1630	1630	1019	1019	-	-	-	-	-	-	-	-	11	11	1019	1630	-	-	-	-
315+91.4	350+70.8	3479.40	DNPZ	3359	3429	6789	6789	6959	6959	-	-	-	-	-	-	-	-	44	44	6959	6789	-	-	-	-
350+70.8	358+36.7	765.90	DNPZ/SKIPDASH	766	766	1532	1532	958	958	-	-	-	-	-	-	-	-	10	10	958	1532	-	-	-	-
358+36.7	416+37.8	5801.10	SKIPDASH	5671	5681	11353	11353	1451	1451	-	-	-	-	-	-	-	-	73	73	1451	11353	-	-	-	-
416+37.8	419+00.0	262.20	SKIPDASH/DNPZ	262	262	525	525	320	320	-	-	-	-	-	-	-	-	4	4	320	525	-	-	-	-
419+00.0	432+17.9	1317.90	DNPZ	1265	1258	2523	2523	2636	2636	-	-	-	-	-	-	-	-	17	17	2636	2523	-	-	-	-
432+17.9	436+17.6	399.68	SKIPDASH/DNPZ	400	400	800	800	500	500	-	-	-	-	-	-	-	-	5	5	500	800	-	-	-	-
436+17.6	447+60.5	1142.92	SKIPDASH	1143	1143	2286	2286	286	286	-	-	-	-	-	-	-	-	15	15	286	2286	-	-	-	-
STATION EQUATION																									
447+40.8	480+49.7	3308.9	SKIPDASH	3269	3309	6578	6578	828	828	-	-	-	-	-	-	-	-	42	42	828	6578	-	-	-	-
480+49.7	503+00.0	2250.3	SKIPDASH/DNPZ	2250	2250	4501	4501	2813	2813	-	-	-	-	-	-	-	-	29	29	2813	4501	-	-	-	-
503+00.0	506+82.2	382.2	DNPZ	192	382	575	575	765	765	-	-	-	-	-	-	-	-	5	5	765	575	-	-	-	-
506+82.2	514+96.6	814.4	DNPZ/SKIPDASH	814	814	1629	1629	1018	1018	-	-	-	-	-	-	-	-	11	11	1018	1629	-	-	-	-
STATION EQUATION																									
653+01.2	660+00.0	698.8	DNPZ/SKIPDASH	699	699	1398	1398	874	874	-	-	-	-	-	-	-	-	9	9	874	1398	-	-	-	-
660+00.0	663+60.8	360.8	DNPZ	361	261	622	622	722	722	-	-	-	-	-	-	-	-	5	5	722	622	-	-	-	-
US 136																									
US 136/IL 100																									
TOTALS:																									
					102564	102564	52169	52169	957	957	570	570	60	60	111	154	766	766	52169	102564	957	570	60	111	

MODEL: Untitled-1 [Sheet]  
FILE NAME: X:\Projects\Current\132-12-15 IDOT D4 PTB216-036 W03 US 24\DCM\Sheet Files\68K17-sh-schedule.dgn



USER NAME = Cblackery	DESIGNED CB	REVISED -
	DRAWN CB	

SHORT TERM PAVEMENT MARKING					
LOCATION	LENGTH	NUMBER OF APPLICATIONS	QUANTITY	QUANTITY	
STATION TO STATION	FOOT		4" YELLOW	4" WHITE	
+0	64+27.4	6427.4	3	1929	0
BRIDGE OMISSION					
65+80.2	70+25.4	445.2	3	134	0
BRIDGE OMISSION					
78+01.3	83+60.8	559.5	3	168	0
BRIDGE OMISSION					
STATION EQUATION					
BRIDGE OMISSION					
85+29.8	89+87.8	458.0	3	483	31
89+87.8	132+25.0	4237.2	3	1272	0
132+25.0	202+59.1	7034.1	2	1407	0
202+59.1	215+19.4	1260.3	2	952	107
215+19.4	255+73.6	4054.2	2	811	0
BRIDGE OMISSION					
258+92.9	274+73.1	1580.2	2	317	0
STATION EQUATION					
275+06.7	447+60.5	17253.8	2	3451	0
STATION EQUATION					
447+40.8	514+96.6	6755.8	2	1352	0
STATION EQUATION					
653+01.2	663+60.8	1059.6	2	212	0
SUBTOTALS(FOOT):				12488	138
TOTAL(FOOT):				12626	

SHORT TERM PAVEMENT MARKING REMOVAL		
LOCATION	LENGTH APPLIED	AREA REMOVED
STATION TO STATION	FOOT	SQ FT
+0	663+60.8	12626.0
TOTAL(SQ FT):		4209

SINUSOIDAL RUMBLE STRIPS, 14"		
LOCATION	LENGTH	
STATION TO STATION	FOOT	
+0	22+62.8	2263
26+62.8	63+65.1	3703
66+37.8	69+65.1	328
94+93.0	127+49.5	3257
131+43.9	133+55.8	212
135+54.3	202+50.7	6697
212+25.1	255+18.4	4294
259+48.0	274+73.1	1526
STATION EQUATION		
275+06.6	279+02.5	396
283+01.9	314+36.3	3135
318+36.5	347+84.5	2948
351+84.1	365+72.0	1388
369+71.5	371+20.4	149
373+18.4	388+49.9	1532
393+05.1	416+37.8	2333
421+44.7	429+79.6	835
433+80.0	447+60.5	1381
STATION EQUATION		
447+40.8	471+56.1	2416
476+93.9	502+76.4	2583
506+77.2	514+96.6	820
STATION EQUATION		
653+01.1	661+07.0	806
TOTAL :		43002

LONGITUDINAL JOINT TRIMMING QUANTITIES								
LOCATION	LENGTH	NOTES	AREA	HOT-MIX ASPHALT SURFACE REMOVAL SPECIAL	POLYMERIZED BITUMINOUS MATERIALS (TACK COAT)	SURFACE COURSE THICKNESS	POLYMERIZED HOT-MIX ASPHALT SURFACE COURSE 1L 9.5, MIX D, N50	
STATION TO STATION	FOOT		SQ FT	SQ YD	POUND	INCH	TON	
+0	64+27.4	6427.4	2 LANES - 1 JOINT	3213.71	358	258	1.75	35
BRIDGE OMISSION								
65+80.2	70+25.4	445.2	2 LANES - 1 JOINT	222.60	25	18	1.75	3
BRIDGE OMISSION								
78+01.3	83+60.8	559.5	2 LANES - 1 JOINT	279.75	32	23	1.75	4
BRIDGE OMISSION								
STATION EQUATION								
BRIDGE OMISSION								
85+29.8	88+21.0	291.2	3 LANES - 3 JOINTS	436.80	49	35	1.75	5
88+21.0	94+67.9	646.9	3 LANES - 2 JOINTS	646.90	72	52	2.75	12
94+67.9	132+25.0	3757.1	2 LANES - 1 JOINT	1878.55	209	151	1.75	21
132+25.0	202+59.0	7034.0	2 LANES - 1 JOINT	3517.00	391	282	1.50	33
202+59.0	202+75.0	16.0	2 LANES - 1 JOINT	8.00	1	1	1.75	1
202+75.0	209+07.0	632.0	3 LANES - 2 JOINTS	632.00	71	51	1.75	7
209+07.0	213+97.7	490.7	4 LANES - 3 JOINTS	735.98	82	59	1.75	9
213+97.7	215+19.4	121.7	2 LANES - 1 JOINT	60.85	7	5	1.75	1
215+19.4	255+73.6	4054.2	2 LANES - 1 JOINT	2027.10	226	163	1.50	19
BRIDGE OMISSION								
258+92.9	274+73.1	1580.2	2 LANES - 1 JOINT	790.10	88	64	1.50	8
STATION EQUATION								
275+06.7	447+60.5	17253.8	2 LANES - 1 JOINT	8626.90	959	691	1.50	81
STATION EQUATION								
447+40.8	514+96.6	6755.8	2 LANES - 1 JOINT	3377.90	376	271	1.50	32
STATION EQUATION								
653+01.2	663+60.8	1059.6	2 LANES - 1 JOINT	529.80	59	43	1.50	5
TOTAL :				3005	2167			276

STEEL PLATE BEAM GUARDRAIL, TYPE A, 5 FOOT POSTS					
BEGIN STATION		END STATION	SIDE		LENGTH (FT)
62+18.00	to	64+18.00	RT		200
65+80.00	to	66+92.50	RT		113
65+90.00	to	67+27.50	LT		138
68+90.50	to	70+03.00	LT		113
68+90.50	to	70+03.00	RT		113
83+28.00	to	83+53.00	LT		25
83+28.00	to	83+53.00	RT		25
85+37.00	to	85+87.00	RT		50
85+37.00	to	87+12.00	LT		175
259+45.00	to	264+33.50	RT		489
260+20.00	to	262+20.00	LT		200
274+34.00	to	277+80.00	RT		346
275+45.50	to	279+58.00	LT		413
320+58.00	to	326+08.00	RT		550
TOTAL					2950

TRAFFIC BARRIER TERMINAL, TYPE 6A			
STATION	SIDE		EACH
259+08.00	RT		1
TOTAL			1

TRAFFIC BARRIER TERMINAL, TYPE 1 (SPECIAL) FLARED			
STATION	SIDE		EACH
63+75.00	LT		1
82+78.00	RT		1
86+37.00	RT		1
TOTAL			3

SIGN PANEL - TYPE 1				
STATION	SIDE	TYPE	AREA (SQ FT)	WOOD POST(FT)
271+25.00	RT	W2-1	6.25	14
		W16-9P	2	
290+25.00	LT	W2-1	6.25	14
		W16-9P	2	
TOTAL			17	28

TRAFFIC BARRIER TERMINAL, TYPE 6			
STATION	SIDE		EACH
64+55.00	RT		1
64+62.00	LT		1
65+43.00	RT		1
65+53.00	LT		1
70+40.00	LT		1
70+40.00	RT		1
83+90.00	LT		1
83+90.00	RT		1
85+00.00	LT		1
85+00.00	RT		1
TOTAL			10

TRAFFIC BARRIER TERMINAL, TYPE 1 (SPECIAL) TANGENT			
STATION	SIDE		EACH
61+68.00	RT		1
67+42.50	RT		1
67+77.50	LI		1
68+40.50	LT		1
68+40.50	RT		1
82+78.00	LT		1
87+62.00	LT		1
259+70.00	LT		1
262+70.00	LT		1
264+83.50	RT		1
273+84.00	RT		1
274+62.00	LT		1
278+30.00	RT		1
280+08.00	LT		1
321+08.00	RT		1
326+58.00	RT		1
TOTAL			16

MODEL: Unlited-2 (Sheet)  
FILE NAME: X:\Projects\Current\132-1215 IDOT D4 PTB216-036 W03 US 24\DCM\Sheet Files\68K17-sh-chedule.dgn



USER NAME = Cblackery	DESIGNED CB	REVISED -
	DRAWN CB	REVISED -
	CHECKED JG	REVISED -
PLOT DATE = 1/30/2026	DATE -	REVISED -

STATE OF ILLINOIS  
DEPARTMENT OF TRANSPORTATION

SCHEDULE OF QUANTITIES

SCALE: SHEET 3 OF 5 SHEETS STA. TO STA.

F.A.P. RTE.	SECTION	COUNTY	TOTAL SHEETS	SHEET NO.
VAR.	(17, 110, 111)RS-5; 18RS-6	FULTON	52	16
CONTRACT NO. 68K17				
ILLINOIS FED. AID PROJECT				

GUARDRAIL REMOVAL				
BEGIN STATION		END STATION	SIDE	FOOT
61+68.00	to	64+55.00	RT	287
63+75.00	to	64+62.00	LT	87
65+43.00	to	67+42.50	RT	200
65+53.00	to	67+77.50	LT	225
68+40.50	to	70+40.00	LT	200
68+40.50	to	70+40.00	RT	200
82+78.00	to	83+90.00	LT	112
82+78.00	to	83+90.00	RT	2112
85+00.00	to	86+37.00	RT	87
85+00.00	to	87+62.00	LT	262
259+08.00	to	264+83.50	RT	425
259+70.00	to	262+70.00	LT	500
273+84.00	to	278+30.00	RT	446
274+62.00	to	280+08.00	LT	546
321+08.00	to	326+58.00	RT	550
TOTAL				6239

RUMBLE STRIP				
LOCATION	LENGTH (FT)	WIDTH (FT)	NUMBER OF RUMBLE STIPS (EACH)	PAY AREA (SQ FT)
US 136	25	16	1	400
US 136 / IL 100	25	13	2	650
TOTAL (SQ FT):				1050

MEDIAN SCHEDULE				
STATION	SIDE	MEDIAN REMOVAL	CONCRETE MEDIAN, TYPE SM-4.24	CONCRETE MEDIAN, TYPE SM-6.06
		SQ FT	SQ FT	SQ FT
88+68.24	RT	156	156	-
208+57.86	LT	444	-	444
504+94.64	RT	256	-	256
TOTAL		856	156	700

HMA SHOULDERS SCHEDULE														
LOCATION	LENGTH	HMA SHOULDER WIDTH		AREA	HOT-MIX ASPHALT SURFACE REMOVAL, 1"	HOT-MIX ASPHALT SURFACE REMOVAL, 2.75"	POLYMERIZED BITUMINOUS MATERIALS (TACK COAT)	HOT-MIX ASPHALT SHOULDERS, 8"	POLYMERIZED HOT-MIX ASPHALT BINDER COURSE, IL 4.75, N50	POLYMERIZED HOT-MIX ASPHALT SURFACE COURSE, IL 9.5, MIX "D", N50	EXCAVATING AND GRADING EXISTING SHOULDER	SHOULDER RUMBLE STRIPS, 8 INCH		
		LT (FT)	RT(FT)										SQ YD	SQ YD
0+00.00	0+35.00	35.0	2	2	15.6	-	-	23	-	1	2	-	70	
+35.0	30+00.0	2965.0	2	2	1317.8	1318	-	1898	-	74	130	-	5544	
30+00.0	30+50.0	50.0	VARIES	VARIES	27.8	28	-	40	-	2	3	-	100	
30+50.0	60+87.0	3037.0	3	3	2024.7	2025	-	2916	-	114	199	-	5650	
60+87.0	63+90.5	303.5	VARIES	VARIES	375.5	376	-	541	-	22	37	-	547	
63+90.5	64+27.4	36.9	VARIES	8	64.7	-	-	94	-	4	7	-	74	
BRIDGE OMISSION														
65+80.2	66+12.3	32.1	8	8	57.1	-	-	83	-	4	6	-	65	
66+12.3	69+90.5	378.2	8	8	672.4	673	-	969	-	38	66	-	657	
69+90.5	70+25.4	34.9	8	8	62.0	-	-	90	-	4	7	-	70	
BRIDGE OMISSION														
78+01.3	78+36.3	35.0	3	3	23.3	-	-	34	-	2	3	-	-	
78+36.3	79+13.4	77.1	VARIES	VARIES	53.6	54	-	78	-	4	6	-	40	
79+13.4	82+24.0	310.6	VARIES	VARIES	352.4	-	353	508	-	20	35	-	559	
82+24.0	83+25.7	101.7	VARIES	VARIES	101.0	102	-	146	-	6	10	-	152	
83+25.7	83+60.7	35.0	6	VARIES	51.5	-	-	75	-	3	6	-	70	
BRIDGE OMISSION														
STATION EQUATION														
BRIDGE OMISSION														
85+29.8	85+64.7	34.9	VARIES	VARIES	50.1	-	-	73	-	3	5	-	70	
85+64.7	94+67.9	903.2	VARIES	VARIES	612.9	613	-	883	-	35	61	-	1400	
94+67.9	97+10.0	242.1	2	2	107.6	108	-	155	-	7	11	-	485	
97+10.0	97+60.0	50.0	VARIES	2.0	25.0	25	-	36	-	2	3	-	100	
97+60.0	111+86.0	1426.0	3.0	2.0	792.2	793	-	1141	-	45	78	-	2852	
111+86.0	112+36.0	50.0	VARIES	2.0	24.8	25	-	36	-	2	3	-	100	
112+36.0	132+00.0	1964.0	2.0	2.0	872.9	873	-	1257	-	49	86	-	3449	
132+00.0	132+25.0	25.0	4.0	4.0	22.2	6.0	-	16	17	-	1	1	50	
132+25.0	202+84.1	7059.1	4.0	4.0	6274.8	1567	-	4518	4700	-	132	142	13696	
202+84.1	215+19.4	1235.3	4.0	4.0	1098.0	448	-	1582	196	67	44	25	1741	
215+19.4	224+30.5	911.1	4.0	4.0	809.9	955	-	584	40	-	81	19	1823	
224+30.5	228+15.8	385.3	4.0	4.0	342.5	110	-	247	234	-	10	8	771	
228+15.8	232+29.9	414.1	4.0	4.0	368.1	367	-	266	-	-	31	9	829	
232+29.9	253+99.8	2169.9	4.0	4.0	1928.8	482	-	1389	1447	-	41	44	4140	
253+99.8	255+43.2	143.4	4.0	4.0	127.5	122	-	92	7	-	11	3	287	
255+43.2	255+73.6	30.4	4.0	4.0	27.0	-	-	20	-	-	3	1	61	
BRIDGE OMISSION														
258+92.9	259+22.5	29.6	4.0	4.0	26.3	-	-	19	-	-	3	1	60	
259+22.5	270+54.1	1131.6	4.0	4.0	1005.9	1006	-	725	-	-	85	23	2224	
270+54.1	274+73.1	419.0	4.0	4.0	372.4	205	-	269	168	-	18	9	838	
STATION EQUATION														
275+06.7	288+27.2	1320.5	4.0	4.0	1173.8	902	-	846	228	-	76	27	1046	
288+27.2	321+06.1	3278.9	4.0	4.0	2914.6	729	-	2099	2186	-	62	66	6341	
321+06.1	326+36.8	530.7	4.0	4.0	471.7	294	-	340	177	-	25	11	1062	
326+36.8	447+60.5	12123.7	4.0	4.0	10776.6	2695	-	7760	8083	-	227	243	23122	
STATION EQUATION														
447+40.8	514+96.6	6755.8	4.0	4.0	6005.2	1502	-	4324	4504	-	127	136	12856	
STATION EQUATION														
653+01.2	663+30.8	1029.6	4.0	4.0	915.2	229	-	659	687	-	20	21	1884	
663+30.8	663+60.8	30.0	4.0	4.0	26.7	-	-	20	20	-	3	1	30	
US 136/IL 100/US 24 INTERSECTIONS														
US 136/IL 100			VARIES	VARIES	419.3	413	-	302	-	24	42	-	-	
US 136			VARIES	VARIES	188.3	173	-	136	-	11	19	-	-	
TOTAL :						19218		353	37289	22694	538	1825	790	94915

MODEL: Unlited-3 [Sheet]  
FILE NAME: X:\Projects\Current\132-1215 IDOT D4 PTB216-036 W03 US 24\IDGN\Sheet Files\468K17-shd-schedule.dgn



USER NAME = Cblackery  
DESIGNED CB  
DRAWN CB  
CHECKED JG  
PLOT DATE = 1/30/2026

DESIGNED CB  
DRAWN CB  
CHECKED JG  
DATE -

REVISED -  
REVISED -  
REVISED -  
REVISED -

STATE OF ILLINOIS  
DEPARTMENT OF TRANSPORTATION

SCHEDULE OF QUANTITIES

SCALE: SHEET 4 OF 5 SHEETS STA. TO STA.

F.A.P. RTE.	SECTION	COUNTY	TOTAL SHEETS	SHEET NO.
VAR.	(17, 110, 111)RS-5; 18RS-6	FULTON	52	17
CONTRACT NO. 68K17				
ILLINOIS FED. AID PROJECT				

EROSION CONTROL CURB REMOVAL				
BEGIN STATION		END STATION	SIDE	FOOT
273+84.00	to	278+30.00	RT	446
274+62.00	to	280+08.00	LT	546
259+08.00	to	264+83.00	RT	575
259+70.00	to	262+70.00	LT	300
TOTAL				1867

GUARDRAIL AGGREGATE EROSION CONTROL						RIPRAP, CLASS A3
BEGIN STATION		END STATION	SIDE	FOOT	TONS	TONS
273+74.00	to	278+40.00	RT	466.0	95	58
274+52.00	to	280+08.00	LT	556.0	113	69
259+08.00	to	264+93.00	RT	585.0	119	73
259+60.00	to	262+70.00	LT	310.0	63	39
TOTAL					390	239

ENTRANCE SCHEDULE									
DESCR.	NOTE	STATION	LT/RT	MATL.	AREA (SF)	INCIDENTAL HOT-MIX ASPHALT SURFACING (TON)	HOT-MIX ASPHALT SURFACE REMOVAL - BUTT JOINT (SQ YD)	AGGREGATE SURFACE COURSE, TYPE B (TON)	POLYMERIZED BITUMINOUS MATERIAL (TACK COAT) (POUND)
MBTO		2+38.0	RT	HMA	293.2	4	33	-	24
PE		2+59.1	LT	HMA	320.0	4	36	-	26
PE		21+15.5	RT	HMA	227.7	3	26	-	19
PRA	E. RUT RD.	24+58.7	LT	HMA	237.1	3	27	-	19
PE/MBTO		24+94.4	RT	HMA	439.1	5	49	-	36
PE		26+16.4	LT	HMA	233.9	3	26	-	19
FE		29+26.5	RT	HMA	232.3	3	26	-	19
MBTO		32+10.2	RT	HMA	230.0	3	26	-	19
PE		32+22.6	LT	HMA	240.0	3	27	-	20
MBTO		38+60.1	RT	AGG	240.3	-	-	3	-
PE		38+89.9	LT	HMA	186.4	3	21	-	15
FE		44+54.9	RT	HMA	273.7	3	31	-	22
FE		45+57.8	LT	HMA	279.7	4	32	-	23
FE		54+19.9	RT	HMA	273.7	3	31	-	22
FE		63+47.1	LT	HMA	273.7	3	31	-	22
FE		67+90.6	RT	AGG	396.5	-	-	5	-
FE		68+08.1	LT	AGG	396.9	-	-	5	-
PRA	CH 11	78+46.6	RT	HMA	1363.9	15	152	-	110
PRA	CH 11	78+46.6	LT	HMA	1342.2	15	150	-	108
FE		82+19.4	LT	AGG	340.0	-	-	4	-
PE		82+31.9	RT	HMA	1114.0	13	124	-	90
FE		88+55.2	RT	HMA	386.4	5	43	-	31
FE	US HWY 136	658+76.0	RT	HMA	228.0	3	26	-	19
PE	US HWY 136	658+90.8	LT	HMA	299.0	4	34	-	24
CE	US HWY 136	659+88.5	RT	HMA	300.4	4	34	-	25
CE		90+71.7	RT	HMA	995.0	11	111	-	80
PE		112+64.5	LT	HMA	232.8	3	26	-	19
MBTO		113+40.5	LT	HMA	287.7	4	32	-	24
PE		113+55.5	RT	HMA	226.6	3	26	-	19
PE/MBTO		118+80.8	RT	HMA	311.1	4	35	-	25
PRA	E. BACK RD.	129+47.8	RT	HMA	1492.0	17	166	-	120
PRA	E. BACK RD.	129+47.8	LT	HMA	2248.8	25	250	-	180
CE	ISABEL	134+55.2	RT	HMA	167.6	2	19	-	14
MBTO		156+15.3	LT	AGG	286.7	-	-	3	-
PE		156+41.7	RT	HMA	218.9	3	25	-	18
PE/MBTO		164+06.2	LT	HMA	148.8	2	17	-	12
PE/MBTO		168+14.0	LT	HMA	150.4	2	17	-	13
PE/MBTO		169+48.1	LT	AGG	149.2	-	-	2	-
PE		191+62.9	RT	HMA	223.0	3	25	-	18
MBTO		191+75.1	LT	AGG	206.3	-	-	2	-
PE		205+17.9	RT	HMA	223.0	3	25	-	18
PRA	E. OTTO RD.	208+90.2	RT	HMA	2147.9	21	239	-	172
FE		243+12.7	LT	AGG	234.0	-	-	3	-
TOTALS:						209	1998	27	1444

ENTRANCE SCHEDULE									
DESCR.	NOTE	STATION	LT/RT	MATL.	AREA (SF)	INCIDENTAL HOT-MIX ASPHALT SURFACING (TON)	HOT-MIX ASPHALT SURFACE REMOVAL - BUTT JOINT (SQ YD)	AGGREGATE SURFACE COURSE, TYPE B (TON)	POLYMERIZED BITUMINOUS MATERIAL (TACK COAT) (POUND)
FE		243+72.2	RT	AGG	237.0	-	-	3	-
FE		248+30.2	LT	AGG	234.0	-	-	3	-
FE		248+54.9	RT	AGG	234.0	-	-	3	-
FE		259+49.3	LT	AGG	145.2	-	-	2	-
PE		280+37.5	LT	HMA	252.4	3	29	-	21
PRA	N. MARBLETON RD.	281+20.9	LT	HMA	1823.6	18	203	-	146
PE/MBTO		303+25.0	LT	HMA	140.6	2	16	-	12
FE		308+03.2	RT	AGG	184.8	-	-	2	-
PRA	N. LOCKARD LN.	316+12.8	RT	HMA	790.7	8	88	-	64
PRA	N. LOCKARD LN.	316+78.9	LT	HMA	898.5	9	100	-	72
PRA	E. SHIELDS LN.	349+83.1	LT	HMA	996.6	10	111	-	80
PE		350+49.1	RT	HMA	147.3	2	17	-	12
PE		352+17.6	RT	HMA	147.2	2	17	-	12
PE		353+72.5	LT	HMA	189.4	2	22	-	16
PRA	LINE RD.	367+74.9	RT	HMA	1187.3	12	132	-	95
PE		370+98.4	LT	HMA	136.2	2	16	-	11
CE		372+19.1	LT	AGG	184.2	-	-	-	-
FE		381+19.2	RT	AGG	170.6	-	-	-	-
FE		381+38.4	LT	AGG	167.6	-	-	2	-
FE		382+40.7	RT	HMA	178.6	2	20	-	15
PRA	WEAVER RD.	390+41.7	RT	HMA	175.4	2	20	-	15
PRA	CH 10	391+05.6	LT	HMA	1993.5	19	222	-	160
PE/MBTO		408+41.1	LT	HMA	365.7	4	41	-	30
FE		411+98.9	RT	HMA	224.5	3	25	-	18
PRA	N. WELKERS RD.	419+46.0	LT	HMA	824.9	8	92	-	66
PE		422+78.4	RT	HMA	187.2	2	21	-	15
PRA	CARDINAL LN.	431+79.6	RT	HMA	845.2	8	94	-	68
PE		437+35.0	LT	HMA	232.6	3	26	-	19
FE		444+16.4	RT	HMA	184.2	2	21	-	15
PE		444+83.2	LT	HMA	220.5	3	25	-	18
PE		459+56.7	RT	AGG	234.7	-	-	3	-
FE		460+38.1	LT	HMA	171.8	2	20	-	14
FE		473+54.7	LT	HMA	195.6	2	22	-	16
PE/PRA	N. HAMBLIN RD.	473+55.9	RT	HMA	265.4	3	30	-	22
PE		474+41.0	RT	HMA	212.3	2	24	-	17
CE		475+93.9	RT	HMA	254.7	3	29	-	21
PE/MBTO		483+35.2	LT	HMA	296.4	3	33	-	24
PRA	N. HAMMACK RD.	504+72.6	RT	HMA	4078.2	39	454	-	327
FE		504+82.7	LT	AGG	230.3	-	-	3	-
PE/MBTO		514+41.2	LT	HMA	536.5	6	60	-	43
PE/MBTO		660+81.0	LT	HMA	284.1	3	32	-	23
FE		661+22.1	RT	AGG	231.5	-	-	3	-
PRA	N. IZAACK WALTON RD.	663+18.1	LT	HMA	1323.6	13	148	-	106
TOTALS:						202	2210	24	1593

MODEL: Untitled4 [Sheet]  
 FILE NAME: X:\Projects\Current\1132-1215 IDOT D4 PTB216-036 W03 US 24\IDGN\Schedule Files\ID68K17-sht-schedule.dgn



USER NAME = Cblackery	DESIGNED CB	REVISED -
	DRAWN CB	REVISED -
	CHECKED JG	REVISED -
PLOT DATE = 1/29/2026	DATE -	REVISED -

**STATE OF ILLINOIS  
DEPARTMENT OF TRANSPORTATION**

**SCHEDULE OF QUANTITIES**

SCALE: SHEET 5 OF 5 SHEETS STA. TO STA.

F.A.P. RTE.	SECTION	COUNTY	TOTAL SHEETS	SHEET NO.
VAR.	(17, 110, 111)RS-5; 18RS-6	FULTON	52	18
CONTRACT NO. 68K17				
ILLINOIS FED. AID PROJECT				

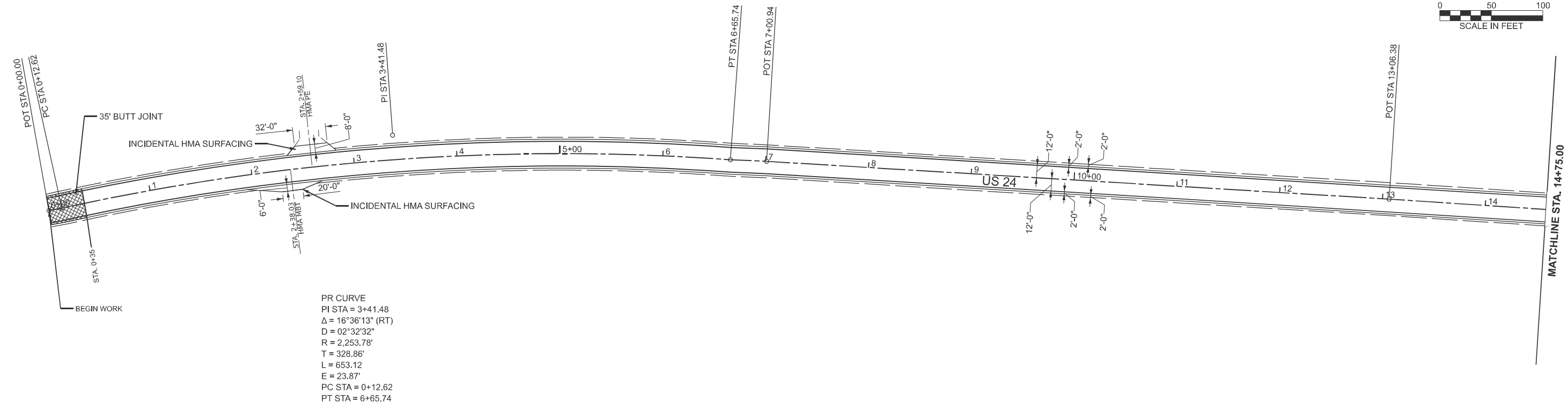
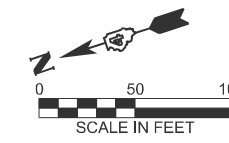

PR CURVE  
 PI STA = 3+41.48  
 $\Delta = 16^\circ 36' 13''$  (RT)  
 $D = 02^\circ 32' 32''$   
 $R = 2,253.78'$   
 $T = 328.86'$   
 $L = 653.12'$   
 $E = 23.87'$   
 PC STA = 0+12.62  
 PT STA = 6+65.74

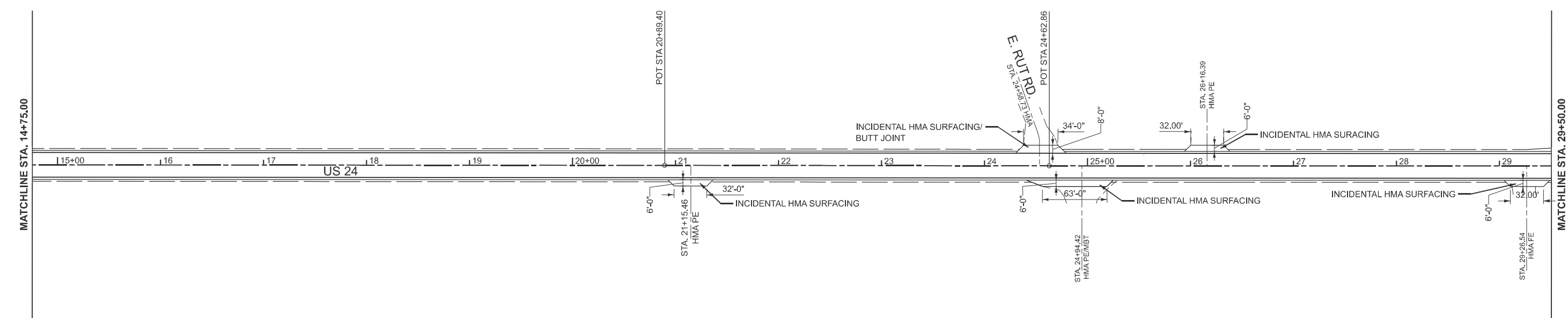
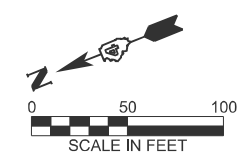

MODEL: P:\C\20 - Plan 1 [Sheet]  
 FILE NAME: X:\Projects\Current\132-1215 IDOT D4 PTB216-036.W03 US 24\Drawn\Sheet Files\468K17-sh-Plan.dgn



USER NAME = Cblackery	DESIGNED CB	REVISED -
	DRAWN CB	REVISED -
	CHECKED JG	REVISED -
PLOT DATE = 1/28/2026	DATE -	REVISED -

**STATE OF ILLINOIS  
 DEPARTMENT OF TRANSPORTATION**

**PLAN SHEET**

SCALE: 1"=50'      SHEET 1      OF 20      SHEETS      STA. 0+00.00      TO STA. 29+50.00

F.A.P. RTE.	SECTION	COUNTY	TOTAL SHEETS	SHEET NO.
VAR.	(17, 110, 111)RS-5; 18RS-6	FULTON	52	19
CONTRACT NO. 68K17				
ILLINOIS FED. AID PROJECT				

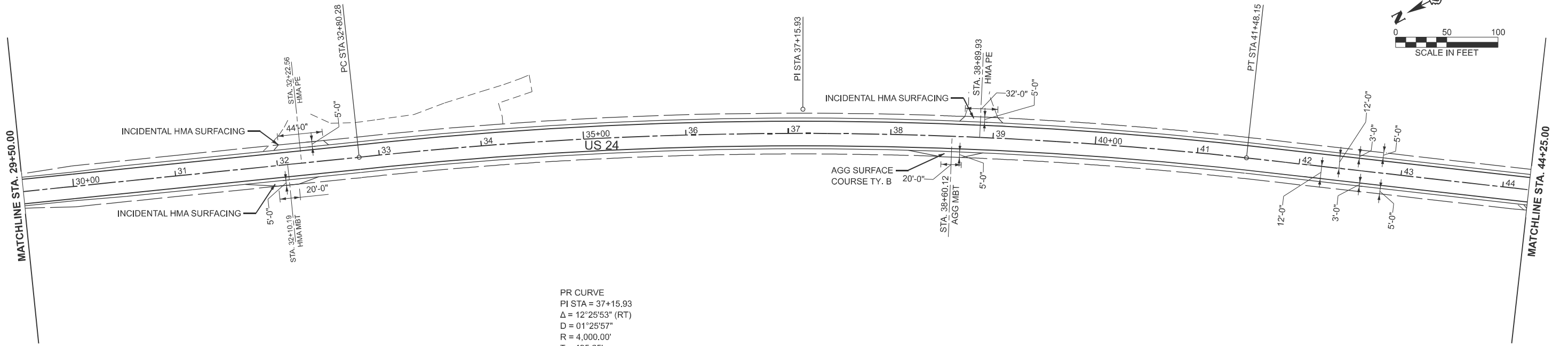

PR CURVE  
 PI STA = 37+15.93  
 $\Delta = 12^{\circ}25'53"$  (RT)  
 $D = 01^{\circ}25'57"$   
 $R = 4,000.00'$   
 $T = 435.65'$   
 $L = 867.87'$   
 $E = 23.65'$   
 $e = 3.6\%$   
 $TR = 40.00'$   
 $SE\ RUN = 200.00'$   
 $PC\ STA = 32+80.28$   
 $PT\ STA = 41+48.15$

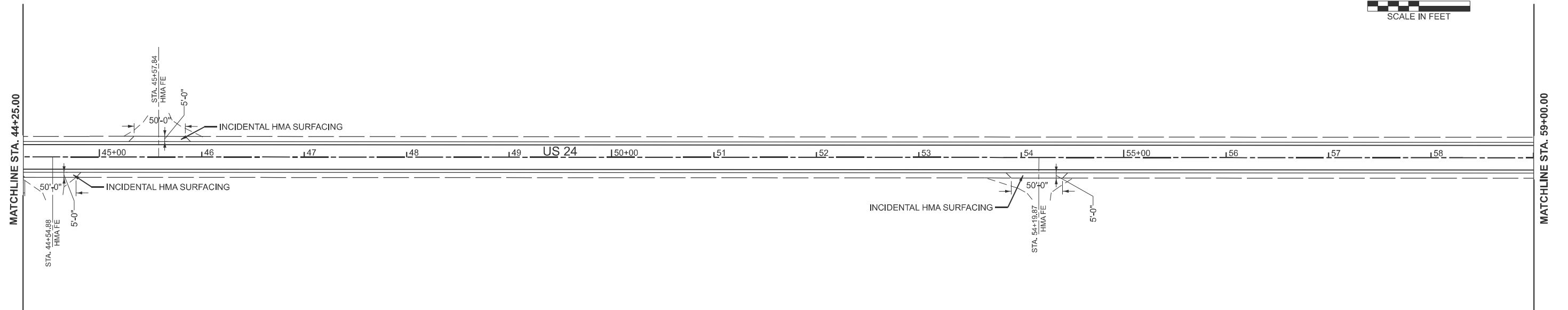

MODEL: P:\C120 - Plan 3 (Sheet)  
 FILE NAME: X:\Projects\Current\132-1215 IDOT D4 PTB216-036 1W03 US 24\DGN\Sheet Files\132-1215-sh-Plan.dgn



USER NAME = Cblackerby	DESIGNED CB	REVISED -
	DRAWN CB	REVISED -
	CHECKED JG	REVISED -
PLOT DATE = 1/29/2026	DATE -	REVISED -

**STATE OF ILLINOIS  
 DEPARTMENT OF TRANSPORTATION**

**PLAN SHEET**

SCALE: 1"=50' SHEET 2 OF 20 SHEETS STA. 29+50.00 TO STA. 59+00.00

F.A.P. RTE.	SECTION	COUNTY	TOTAL SHEETS	SHEET NO.
VAR.	(17, 110, 111)RS-5; 18RS-6	FULTON	52	20
CONTRACT NO. 68K17				
ILLINOIS FED. AID PROJECT				

PR CURVE  
 PI STA = 71+34.68  
 $\Delta = 28^{\circ}53'56''$  (LT)  
 $D = 01^{\circ}15'23''$   
 $R = 4,560.00'$   
 $T = 1,175.00'$   
 $L = 2299.97'$   
 $E = 148.95'$   
 $e = 3.3\%$   
 $TR = 41.28'$   
 $SE RUN = 196.85'$   
 $PC STA = 59+59.68$   
 $PT STA = 82+59.65$

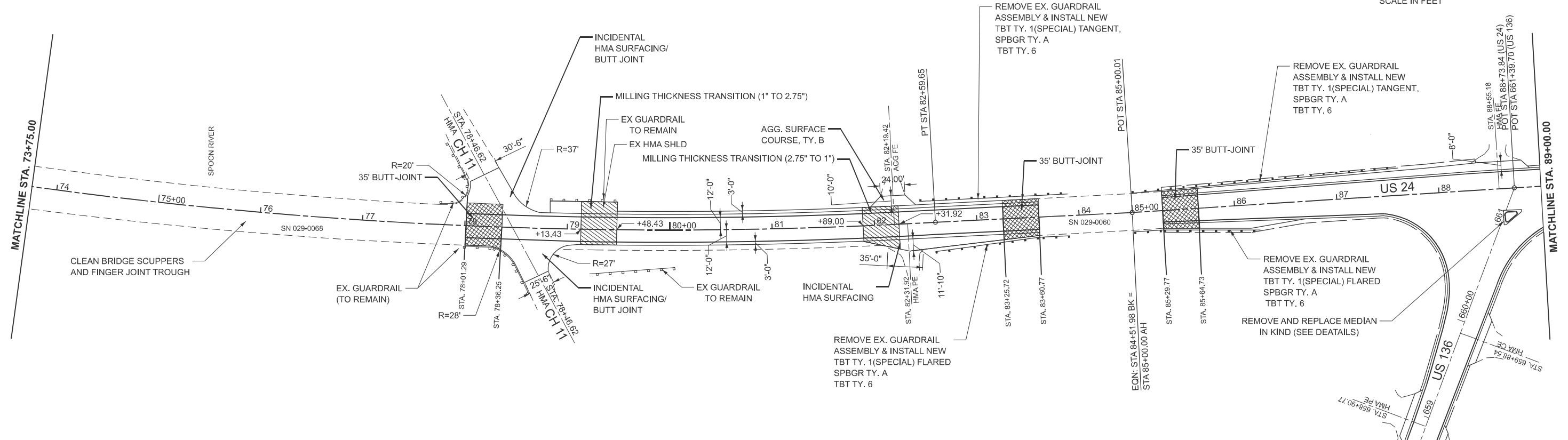
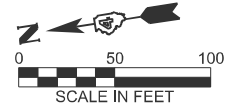
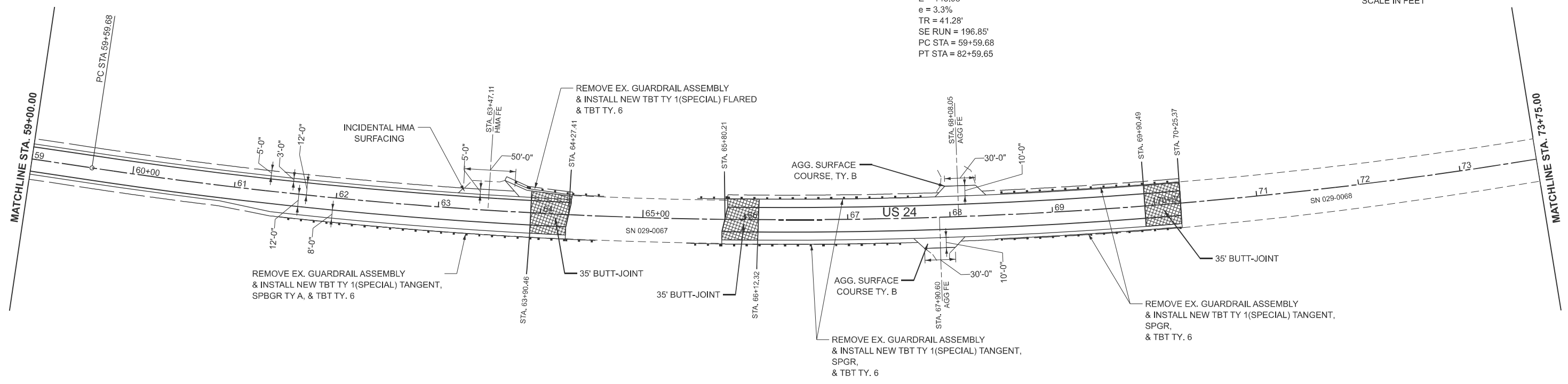
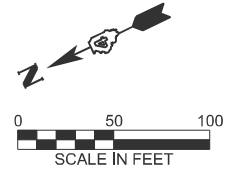

MODEL: P:\C120 - Plan 5 (Sheet)  
 FILE NAME: X:\Projects\Current\132-1215 IDOT D4 PTB216-036 W03 US 24\DWG\Sheet Files\68K17-sh1-plan.dgn



USER NAME = Cblackery	DESIGNED CB	REVISED -
	DRAWN CB	REVISED -
	CHECKED JG	REVISED -
PLOT DATE = 1/29/2026	DATE -	REVISED -

**STATE OF ILLINOIS  
 DEPARTMENT OF TRANSPORTATION**

**PLAN SHEET**

SCALE: 1"=50' SHEET 3 OF 20 SHEETS STA. 59+00.00 TO STA. 89+00.00

F.A.P. RTE.	SECTION	COUNTY	TOTAL SHEETS	SHEET NO.
VAR. (17, 110, 111)RS-5; 18RS-6		FULTON	52	21
CONTRACT NO. 68K17				

ILLINOIS FED. AID PROJECT

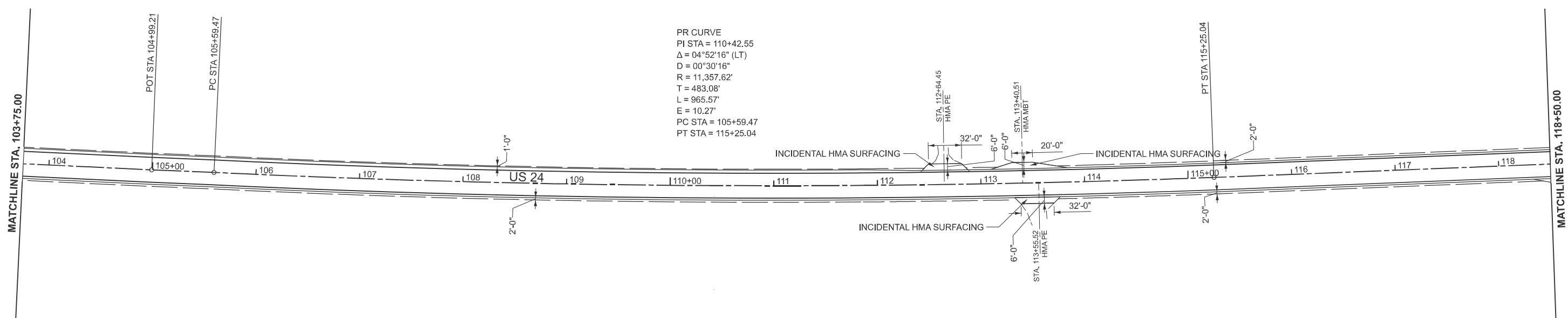
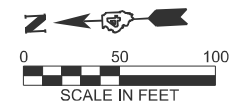
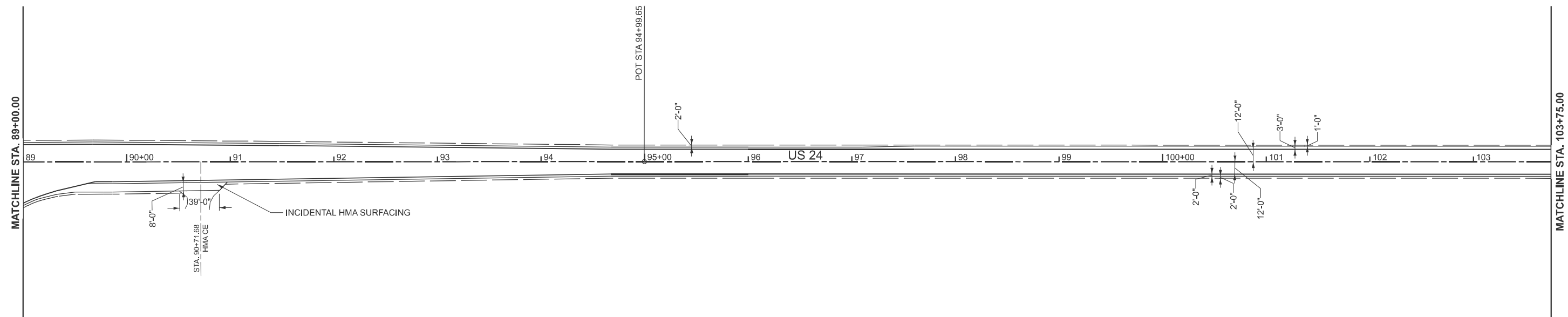
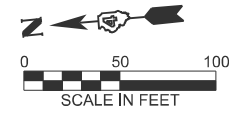

MODEL: P:\C120 - Plan 7 (Sheet)  
 FILE NAME: X:\Projects\Current\132-1215 IDOT D4 PTB216-036 W03 US 24\DWG\Sheet Files\68K17-sh-Plan.dgn



USER NAME = Cblackery	DESIGNED CB	REVISED -
	DRAWN CB	REVISED -
	CHECKED JG	REVISED -
PLOT DATE = 1/29/2026	DATE -	REVISED -

**STATE OF ILLINOIS  
 DEPARTMENT OF TRANSPORTATION**

**PLAN SHEET**

SCALE: 1"=50'      SHEET 4      OF 20      SHEETS      STA. 89+00.00      TO STA. 118+50.00

F.A.P. RTE.	SECTION	COUNTY	TOTAL SHEETS	SHEET NO.
VAR.	(17, 110, 111)RS-5; 18RS-6	FULTON	52	22
CONTRACT NO. 68K17				
ILLINOIS FED. AID PROJECT				

MODEL: P:\C120 - Plan 9 [Sheet]  
 FILE NAME: X:\Projects\Current\132-1215 IDOT D4 PTB216-036 1W03 US 24\DGNSheet Files\468K17-sh-Plan.dgn

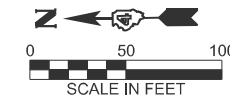
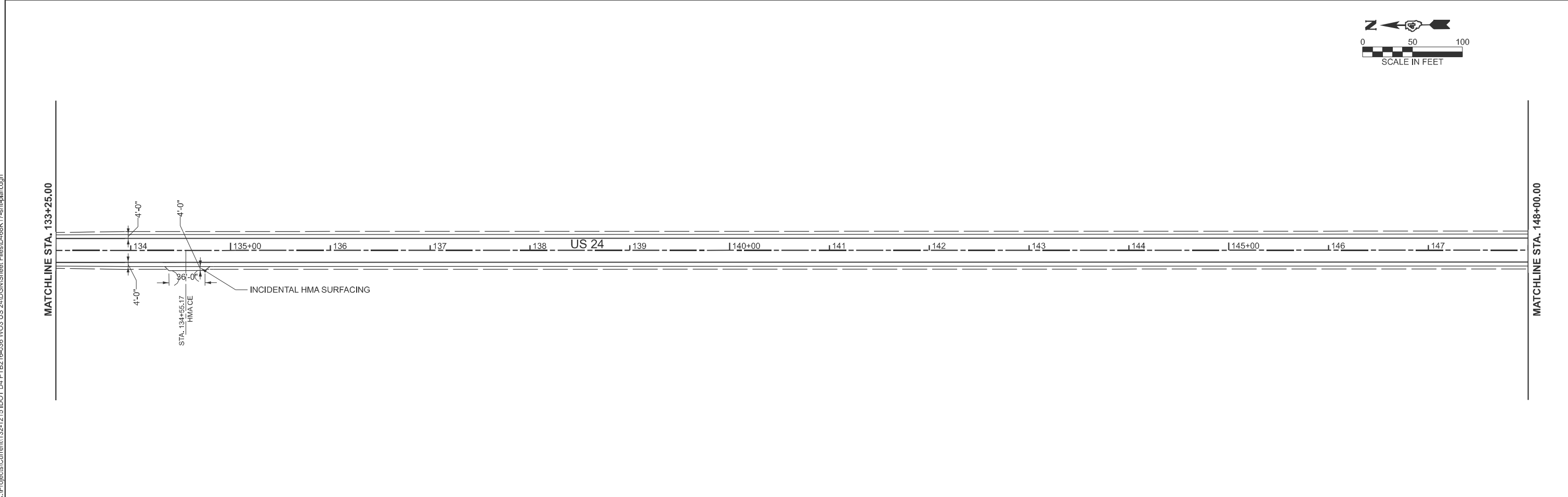
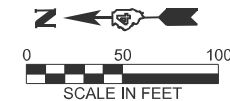
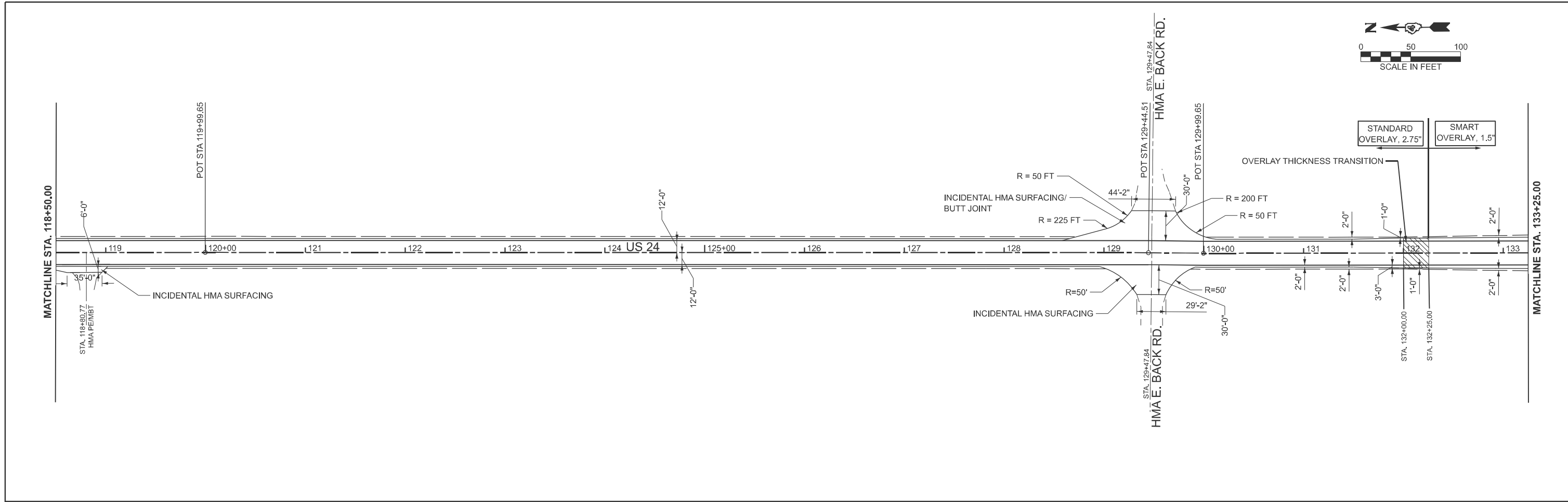

USER NAME = Cblackerby	DESIGNED CB	REVISED -
	DRAWN CB	REVISED -
	CHECKED JG	REVISED -
PLOT DATE = 1/29/2026	DATE -	REVISED -

**STATE OF ILLINOIS  
 DEPARTMENT OF TRANSPORTATION**

**PLAN SHEET**

SCALE: 1"=50' SHEET 5 OF 20 SHEETS STA. 118+50.00 TO STA. 148+00.00

F.A.P. RTE.	SECTION	COUNTY	TOTAL SHEETS	SHEET NO.
VAR.	(17, 110, 111)RS-5; 18RS-6	FULTON	52	23
CONTRACT NO. 68K17				
ILLINOIS FED. AID PROJECT				

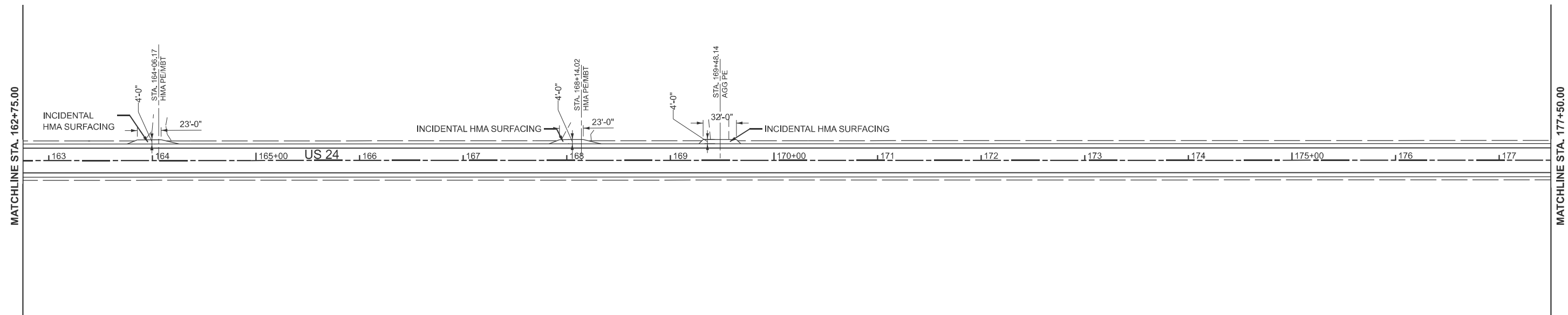
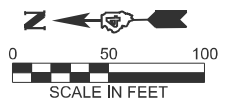
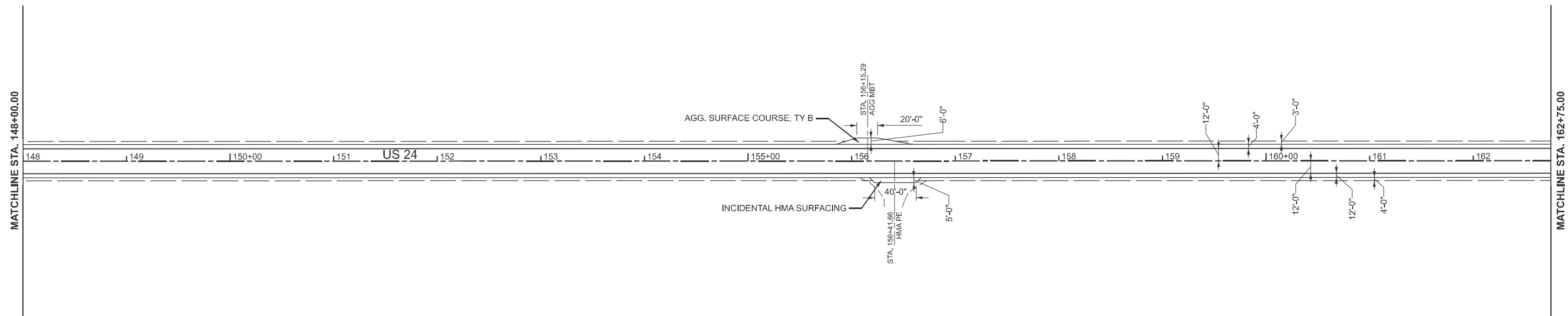
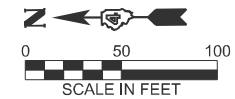

MODEL: P:\C\20 - Plan 11 (Sheet)  
 FILE NAME: X:\Projects\Current\132-1215 IDOT D4 PTB216-036.W03 US 24\DGNSheet Files\0468K17-sh-plan.dgn



USER NAME = Cblackery	DESIGNED CB	REVISED -
	DRAWN CB	REVISED -
	CHECKED JG	REVISED -
PLOT DATE = 1/29/2026	DATE -	REVISED -

**STATE OF ILLINOIS  
 DEPARTMENT OF TRANSPORTATION**

**PLAN SHEET**

SCALE: 1"=50' SHEET 6 OF 20 SHEETS STA. 148+00.00 TO STA. 177+50.00

F.A.P. RTE.	SECTION	COUNTY	TOTAL SHEETS	SHEET NO.
VAR.	(17, 110, 111)RS-5; 18RS-6	FULTON	52	24
CONTRACT NO. 68K17				
ILLINOIS FED. AID PROJECT				

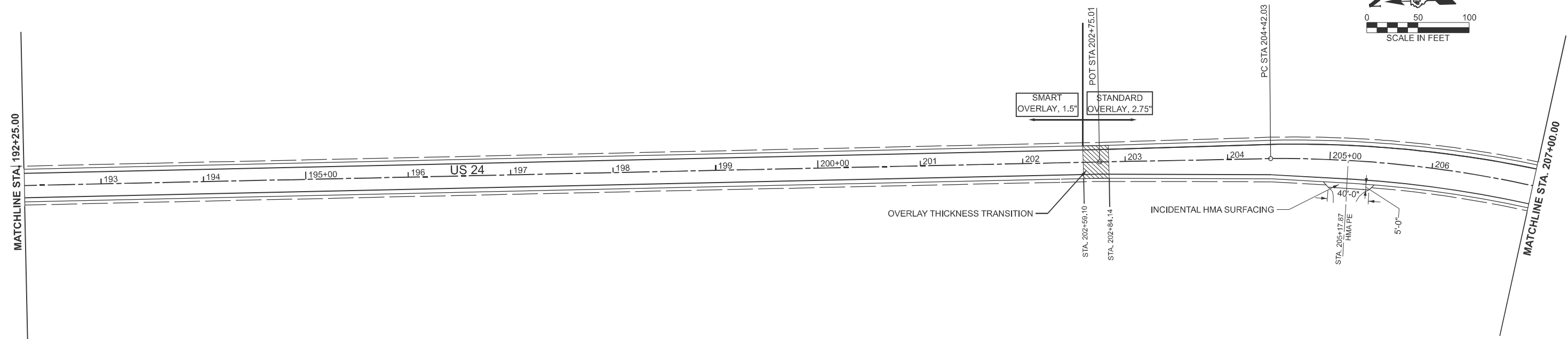
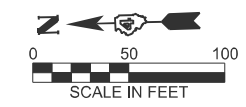
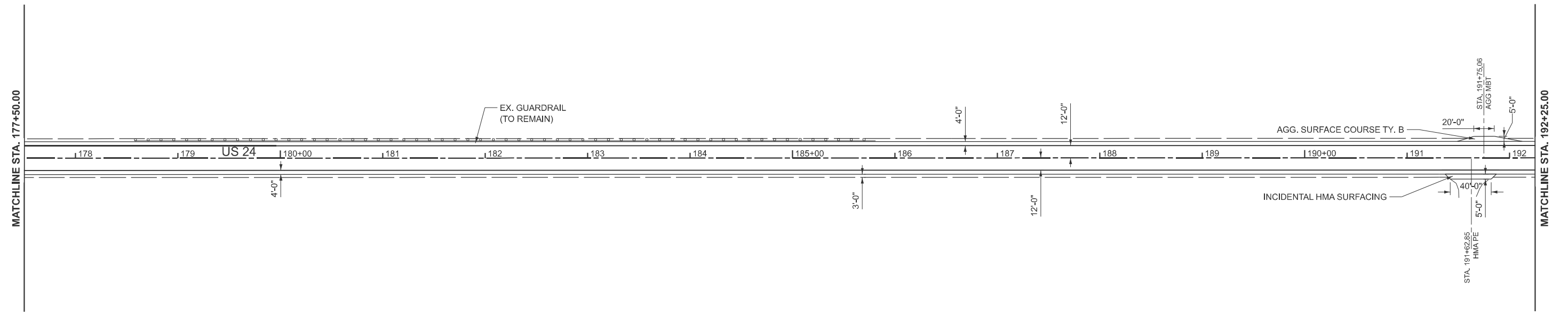
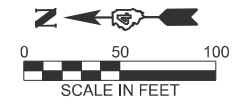

MODEL: PC120 - Plan 13 (Sheet)  
 FILE NAME: X:\Projects\Current\132-1215 IDOT D4 PTB216-036.W03 US 24\DGN\Sheet Files\132-1215-Plan.dgn



USER NAME = Cblackery	DESIGNED CB	REVISED -
	DRAWN CB	REVISED -
	CHECKED JG	REVISED -
PLOT DATE = 1/29/2026	DATE -	REVISED -

**STATE OF ILLINOIS  
DEPARTMENT OF TRANSPORTATION**

**PLAN SHEET**

SCALE: 1"=50'    SHEET 7    OF 20    SHEETS    STA. 177+50.00    TO STA. 207+00.00

F.A.P. RTE.	SECTION	COUNTY	TOTAL SHEETS	SHEET NO.
VAR.	(17, 110, 111)RS-5; 18RS-6	FULTON	52	25
CONTRACT NO. 68K17				
ILLINOIS FED. AID PROJECT				

MODEL: P:\C\20 - Plan 15 (Sheet)  
 FILE NAME: X:\Projects\Current\132-1215 IDOT D4 PTB216-036 I\03 US 24\DWG\Sheet Files\132-1215-sh-Plan.dgn

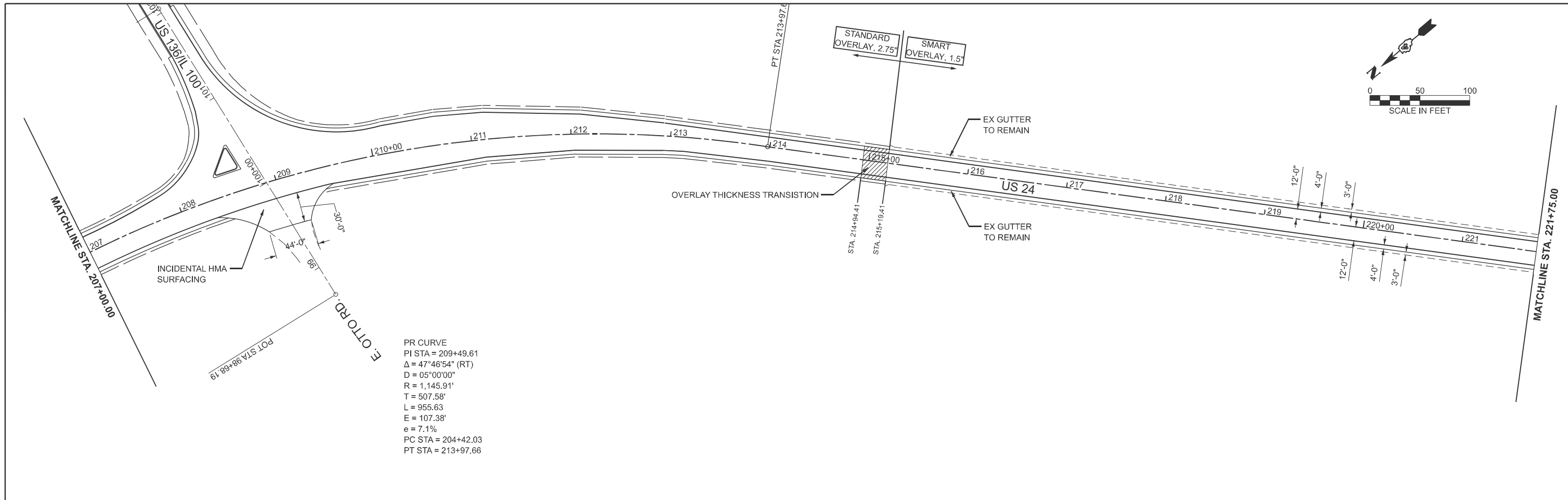

PR CURVE  
 PI STA = 209+49.61  
 $\Delta = 47^{\circ}46'54''$  (RT)  
 $D = 05^{\circ}00'00''$   
 $R = 1,145.91'$   
 $T = 507.58'$   
 $L = 955.63'$   
 $E = 107.38'$   
 $e = 7.1\%$   
 PC STA = 204+42.03  
 PT STA = 213+97.66

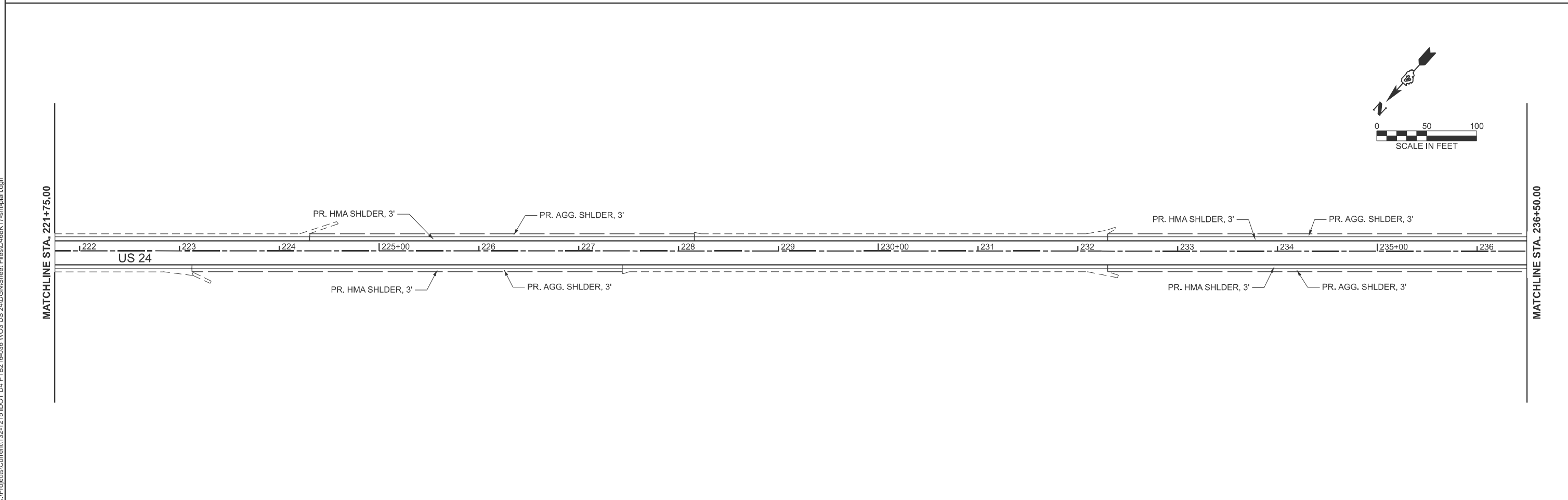

USER NAME = Cblackery	DESIGNED CB	REVISED -
	DRAWN CB	REVISED -
	CHECKED JG	REVISED -
PLOT DATE = 1/29/2026	DATE -	REVISED -

**STATE OF ILLINOIS  
 DEPARTMENT OF TRANSPORTATION**

<b>PLAN SHEET</b>	
SCALE: 1"=50'	SHEET 8 OF 20 SHEETS
STA. 207+00.00	TO STA. 236+50.00

F.A.P. RTE.	SECTION	COUNTY	TOTAL SHEETS	SHEET NO.
VAR.	(17, 110, 111)RS-5; 18RS-6	FULTON	52	26
CONTRACT NO. 68K17				
ILLINOIS FED. AID PROJECT				

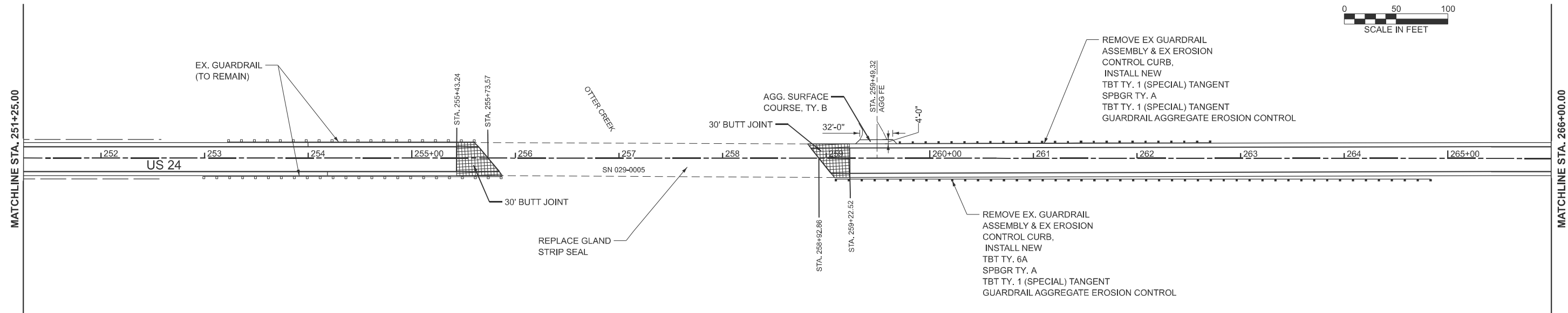
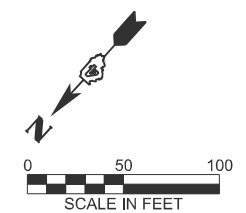
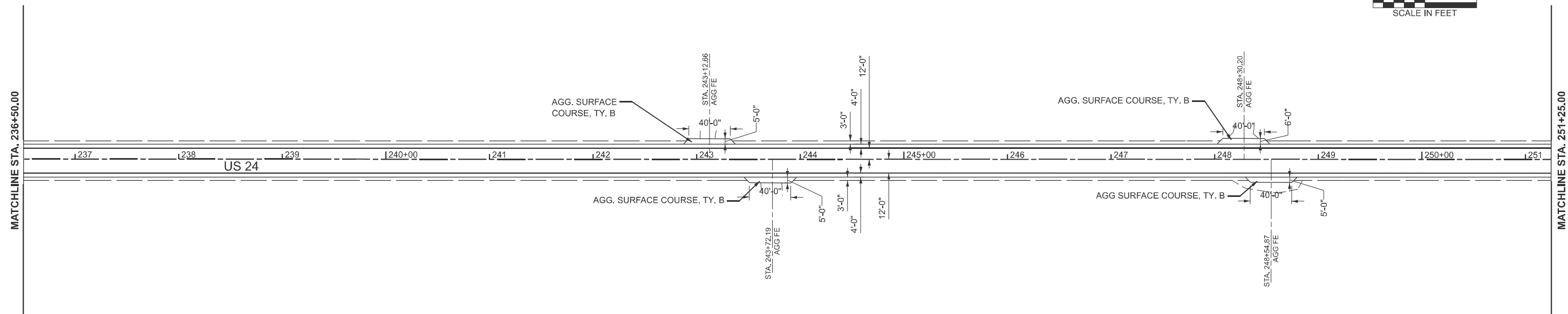
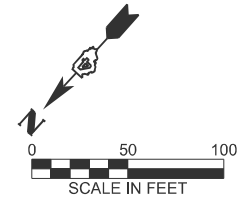

MODEL: P:\C\20 - Plan 17 (Sheet)  
 FILE NAME: X:\Projects\Current\132-1215 IDOT D4 PTB216-036 1W03 US 24\DWG\Sheet Files\68K17-sh-Plan.dgn



USER NAME = Cblackery	DESIGNED CB	REVISED -
	DRAWN CB	REVISED -
	CHECKED JG	REVISED -
PLOT DATE = 1/29/2026	DATE -	REVISED -

**STATE OF ILLINOIS**  
**DEPARTMENT OF TRANSPORTATION**

**PLAN SHEET**  
 SCALE: 1"=50'    SHEET 9 OF 20 SHEETS    STA. 236+50.00 TO STA. 266+00.00

F.A.P. RTE.	SECTION	COUNTY	TOTAL SHEETS	SHEET NO.
VAR.	(17, 110, 111)RS-5; 18RS-6	FULTON	52	27
CONTRACT NO. 68K17				
ILLINOIS FED. AID PROJECT				

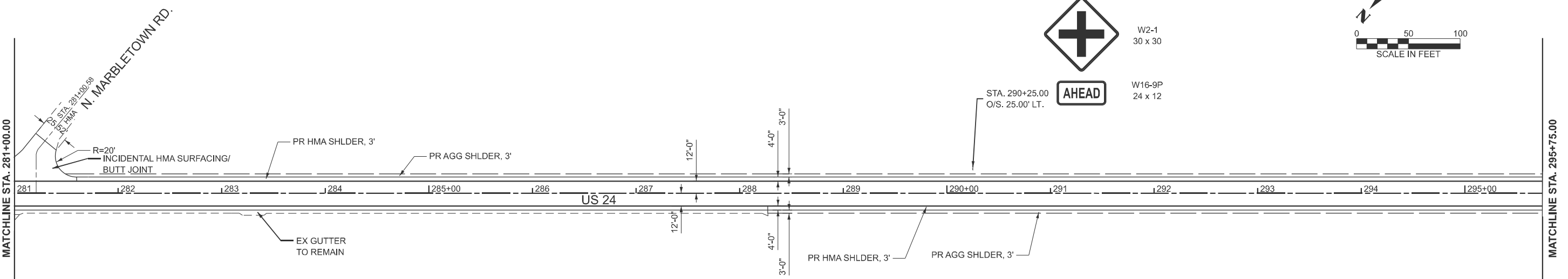
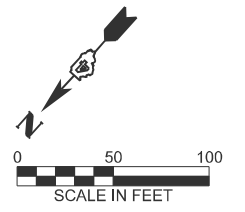
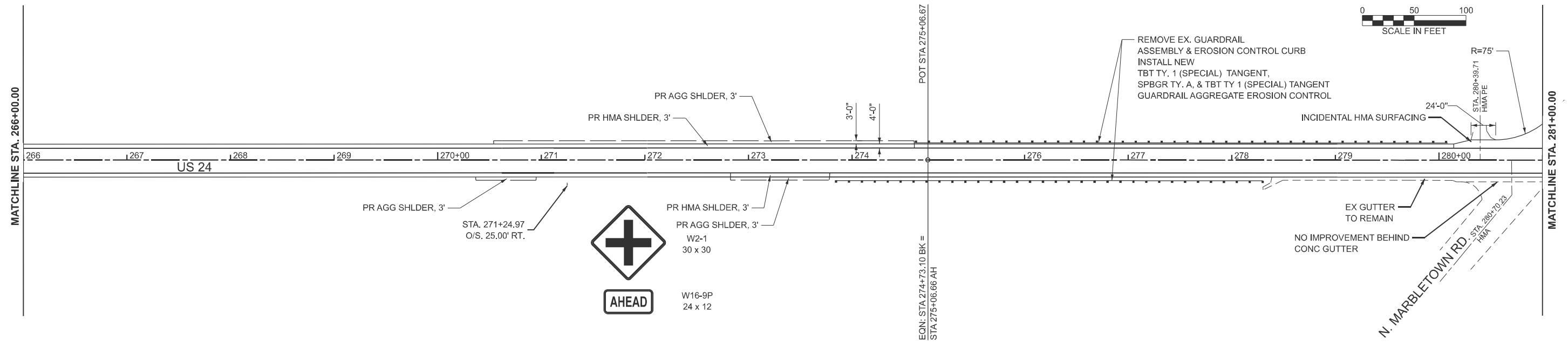
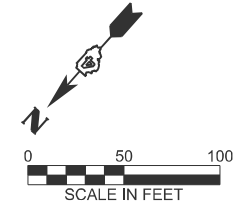

MODEL: P:\C\20 - Plan 19 (Sheet)  
 FILE NAME: X:\Projects\Current\132-1215 IDOT D4 PTB216-036.W03 US 24\DCN\Sheet Files\ID68K17-sh-plan.dgn



USER NAME = Cblackerby	DESIGNED CB	REVISED -
	DRAWN CB	REVISED -
	CHECKED JG	REVISED -
PLOT DATE = 1/29/2026	DATE -	REVISED -

**STATE OF ILLINOIS  
DEPARTMENT OF TRANSPORTATION**

**PLAN SHEET**

SCALE: 1"=50'      SHEET 10 OF 20 SHEETS      STA. 266+00.00 TO STA. 295+75.00

F.A.P. RTE.	SECTION	COUNTY	TOTAL SHEETS	SHEET NO.
VAR.	(17, 110, 111)RS-5; 18RS-6	FULTON	52	28
CONTRACT NO. 68K17				
ILLINOIS FED. AID PROJECT				

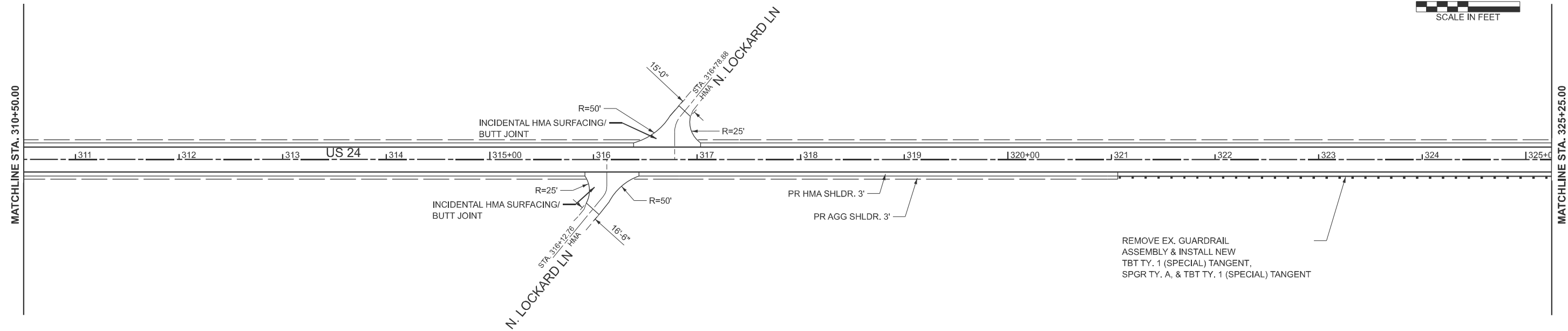
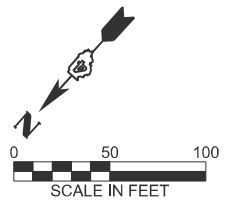
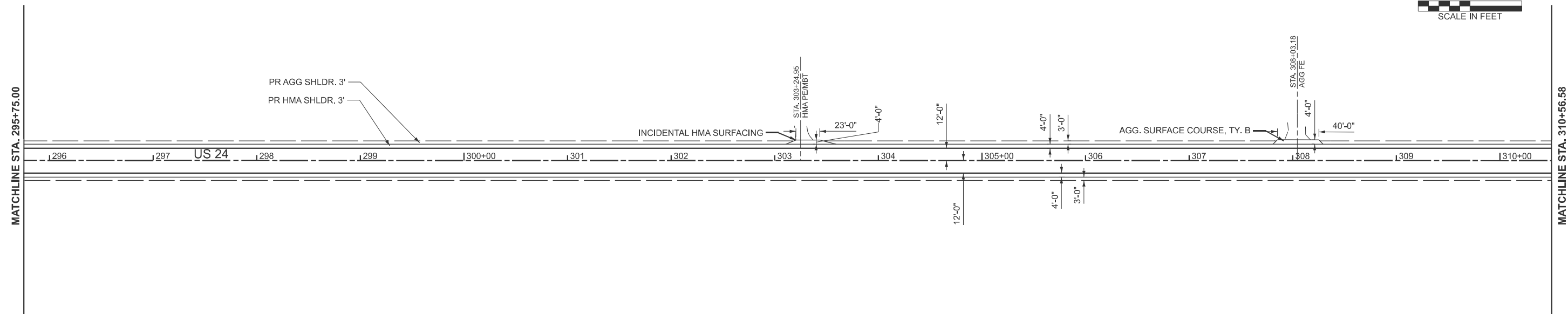
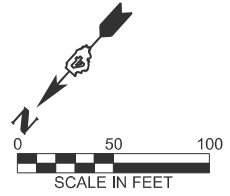

MODEL: P:\C120 - Plan 21 (Sheet)  
 FILE NAME: X:\Projects\Current\132-1215 IDOT D4 PTB216-036 W03 US 24\DWG\Sheet Files\0468K17-sh1-plan.dgn



USER NAME = Cblackerby	DESIGNED CB	REVISED -
	DRAWN CB	REVISED -
	CHECKED JG	REVISED -
PLOT DATE = 1/29/2026	DATE -	REVISED -

**STATE OF ILLINOIS  
DEPARTMENT OF TRANSPORTATION**

**PLAN SHEET**

SCALE: 1"=50'      SHEET 11 OF 20 SHEETS      STA. 295+75.00 TO STA. 325+25.00

F.A.P. RTE.	SECTION	COUNTY	TOTAL SHEETS	SHEET NO.
VAR.	(17, 110, 111)RS-5; 18RS-6	FULTON	52	29
CONTRACT NO. 68K17				
ILLINOIS FED. AID PROJECT				

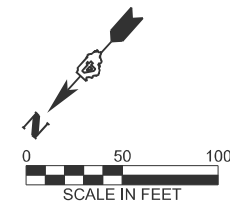

MATCHLINE STA. 325+25.00

MATCHLINE STA. 340+00.00

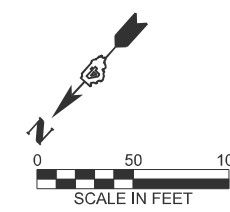
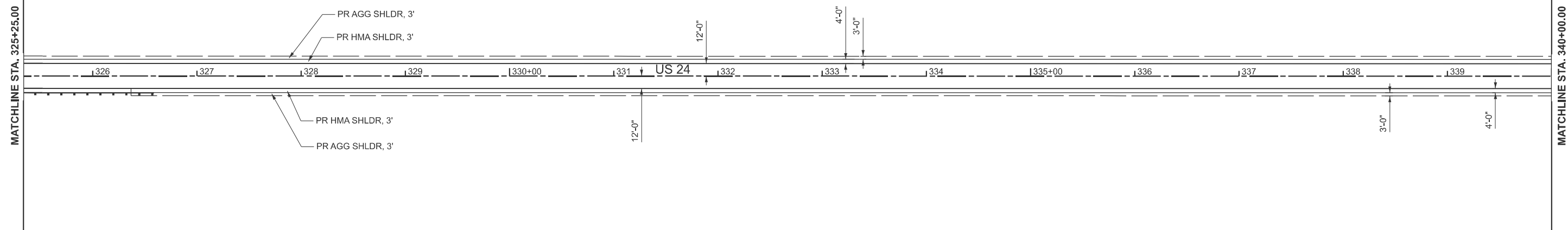

MATCHLINE STA. 340+00.00

MATCHLINE STA. 354+75.00

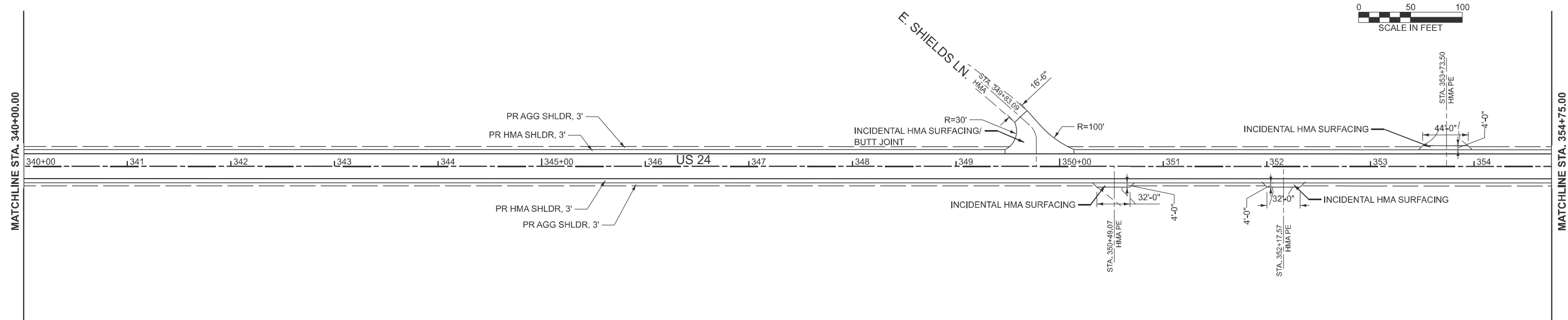

MODEL: P:\C\20 - Plan 23 (Sheet)  
 FILE NAME: X:\Projects\Current\132-1215 IDOT D4 PTB216-036 1\03 US 24\DWG\Sheet Files\0468K17-sh1-plan.dgn



USER NAME = Cblackerby	DESIGNED CB	REVISED -
	DRAWN CB	REVISED -
	CHECKED JG	REVISED -
PLOT DATE = 1/29/2026	DATE -	REVISED -

**STATE OF ILLINOIS  
 DEPARTMENT OF TRANSPORTATION**

**PLAN SHEET**

SCALE: 1"=50' SHEET 12 OF 20 SHEETS STA. 325+25.00 TO STA. 354+75.00

F.A.P. RTE.	SECTION	COUNTY	TOTAL SHEETS	SHEET NO.
VAR.	(17, 110, 111)RS-5; 18RS-6	FULTON	52	30
CONTRACT NO. 68K17				
ILLINOIS FED. AID PROJECT				

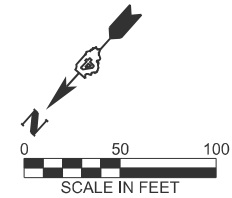

MATCHLINE STA. 354+75.00

MATCHLINE STA. 369+50.00

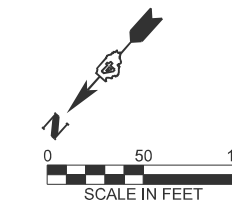
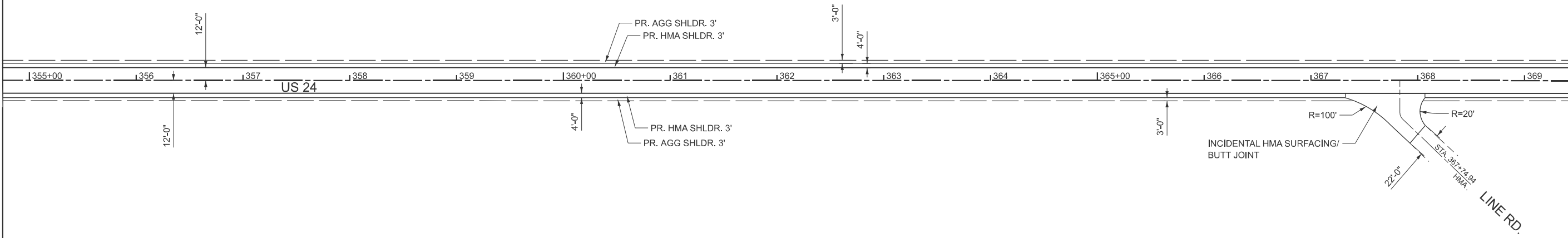

MATCHLINE STA. 369+50.00

MATCHLINE STA. 384+25.00

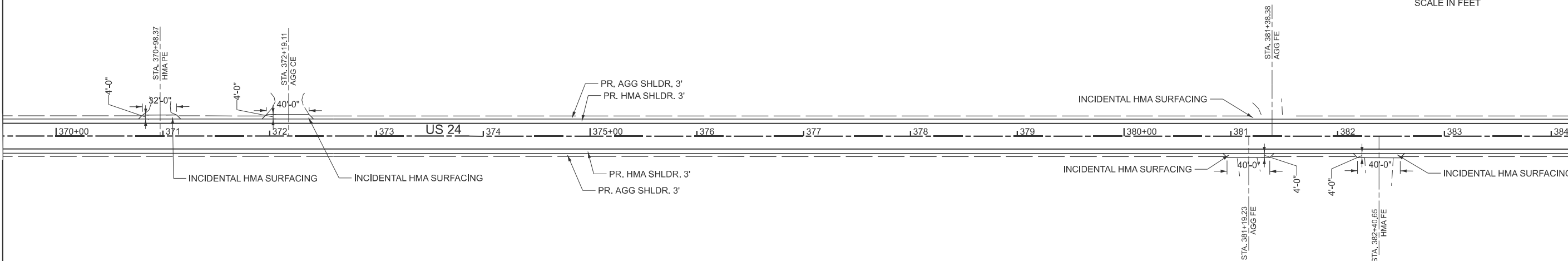

MODEL: PCI20 - Plan 25 (Sheet)  
FILE NAME: X:\Projects\Current\132-1215 IDOT D4 PTB216-036 1W03 US 24\DWG\Sheet Files\468K17-sh1-plan.dgn



USER NAME = Cblackerby	DESIGNED CB	REVISED -
	DRAWN CB	REVISED -
	CHECKED JG	REVISED -
PLOT DATE = 1/29/2026	DATE -	REVISED -

**STATE OF ILLINOIS  
DEPARTMENT OF TRANSPORTATION**

**PLAN SHEET**

SCALE: 1"=50' SHEET 13 OF 20 SHEETS STA. 354+75.00 TO STA. 384+25.00

F.A.P. RTE.	SECTION	COUNTY	TOTAL SHEETS	SHEET NO.
VAR.	(17, 110, 111)RS-5; 18RS-6	FULTON	52	31
CONTRACT NO. 68K17				
ILLINOIS FED. AID PROJECT				

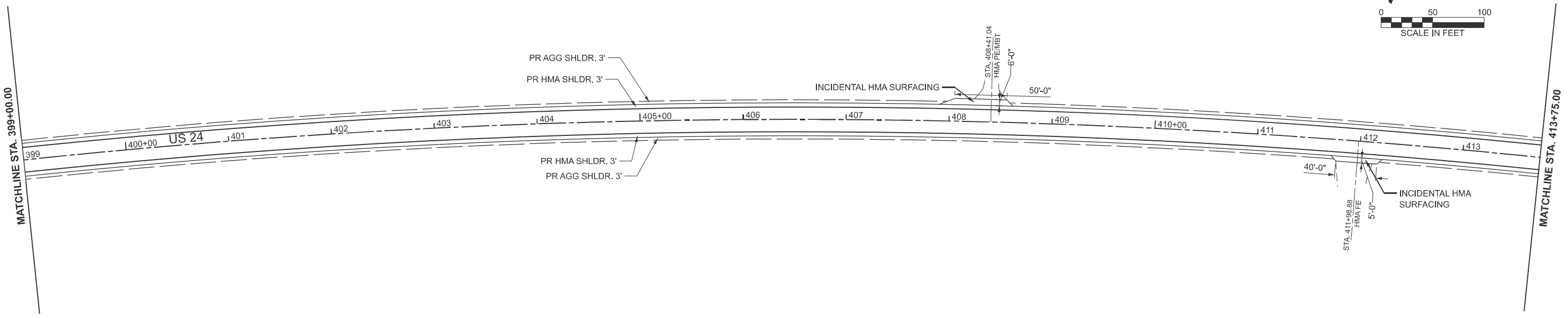
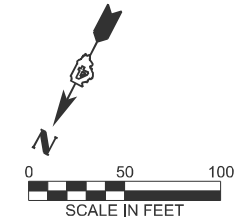
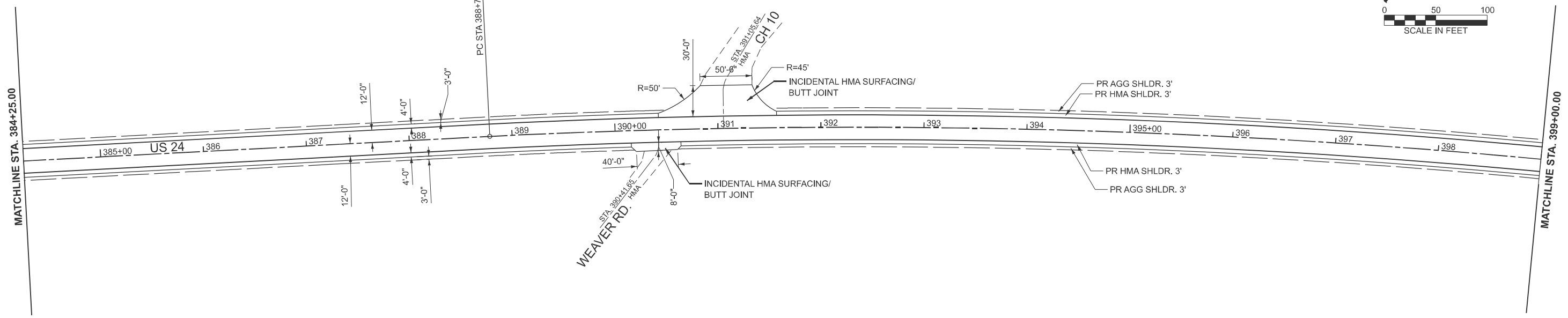
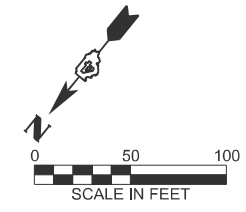

MODEL: P:\C\20 - Plan 27 (Sheet)  
 FILE NAME: X:\Projects\Current\132-1215 IDOT D4 PTB216-036.W03 US 24\DWG\Sheet Files\68K17-sht-plan.dgn



USER NAME = Cblackery	DESIGNED CB	REVISED -
	DRAWN CB	REVISED -
	CHECKED JG	REVISED -
PLOT DATE = 1/29/2026	DATE -	REVISED -

**STATE OF ILLINOIS  
DEPARTMENT OF TRANSPORTATION**

**PLAN SHEET**

SCALE: 1"=50'      SHEET 14    OF 20    SHEETS    STA. 384+25.00    TO STA. 413+75.00

F.A.P. RTE.	SECTION	COUNTY	TOTAL SHEETS	SHEET NO.
VAR.	(17, 110, 111)RS-5; 18RS-6	FULTON	52	32
CONTRACT NO. 68K17				

ILLINOIS FED. AID PROJECT

MODEL: P:\C\20 - Plan 29 (Sheet)  
 FILE NAME: X:\Projects\Current\132-1215 IDOT D4 PTB216-036.W03 US 24\DGN\Sheet Files\468K17-sht-plan.dgn

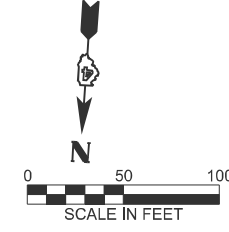
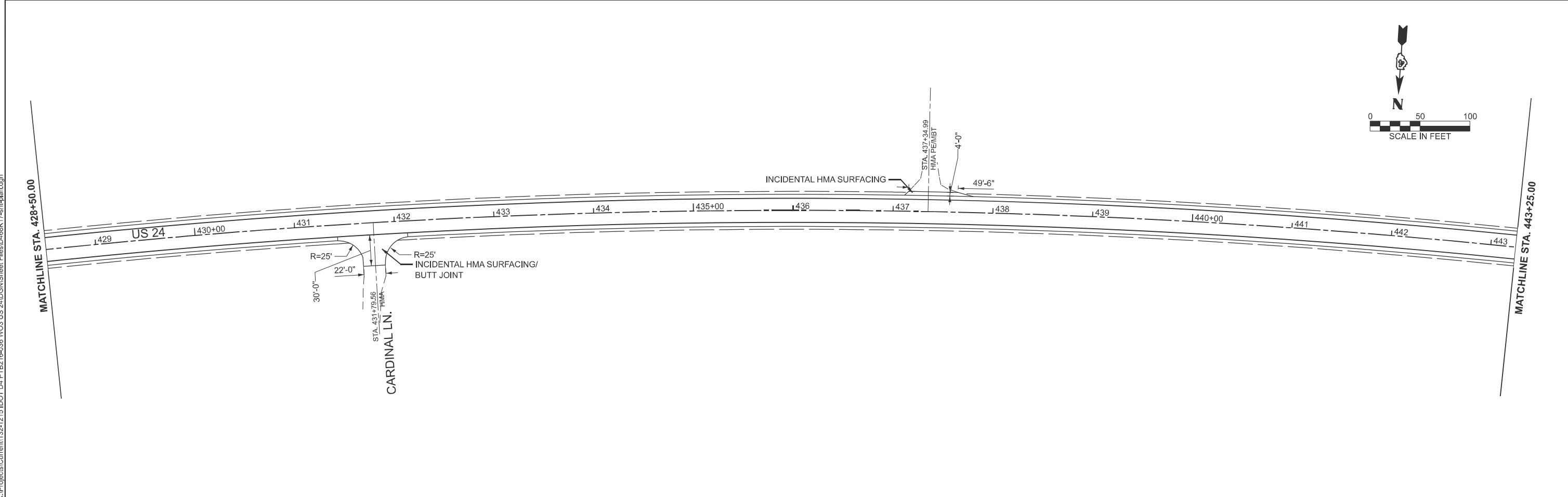
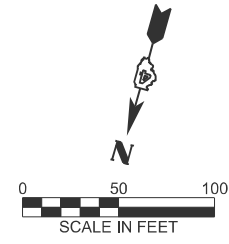
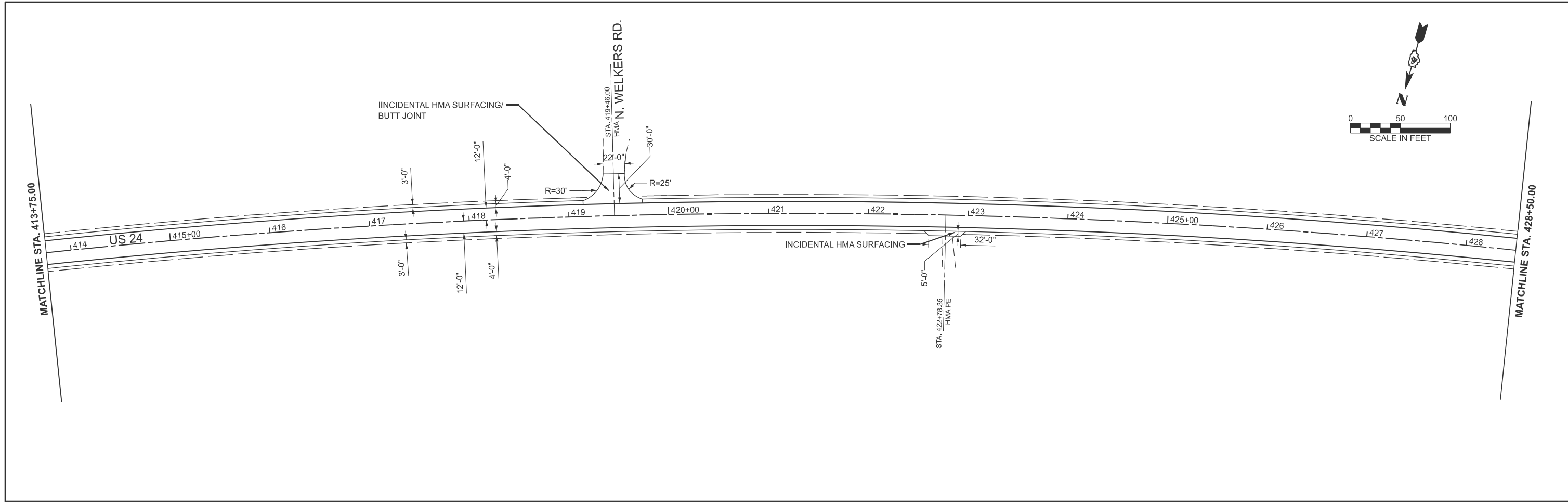

USER NAME = Cblackerby	DESIGNED CB	REVISED -
	DRAWN CB	REVISED -
	CHECKED JG	REVISED -
PLOT DATE = 1/29/2026	DATE -	REVISED -

**STATE OF ILLINOIS  
 DEPARTMENT OF TRANSPORTATION**

**PLAN SHEET**

SCALE: 1"=50' SHEET 15 OF 20 SHEETS STA. 413+75.00 TO STA. 443+25.00

F.A.P. RTE.	SECTION	COUNTY	TOTAL SHEETS	SHEET NO.
VAR.	(17, 110, 111)RS-5; 18RS-6	FULTON	52	33
CONTRACT NO. 68K17				
ILLINOIS FED. AID PROJECT				

MODEL: P:\C120 - Plan 31 (Sheet)  
 FILE NAME: X:\Projects\Current\132-1215 IDOT D4 PTB216-036 1W03 US 24\DWG\Sheet Files\168K17-sh1-plan.dgn

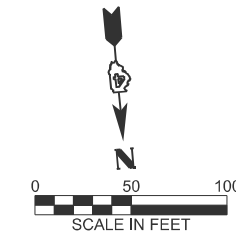
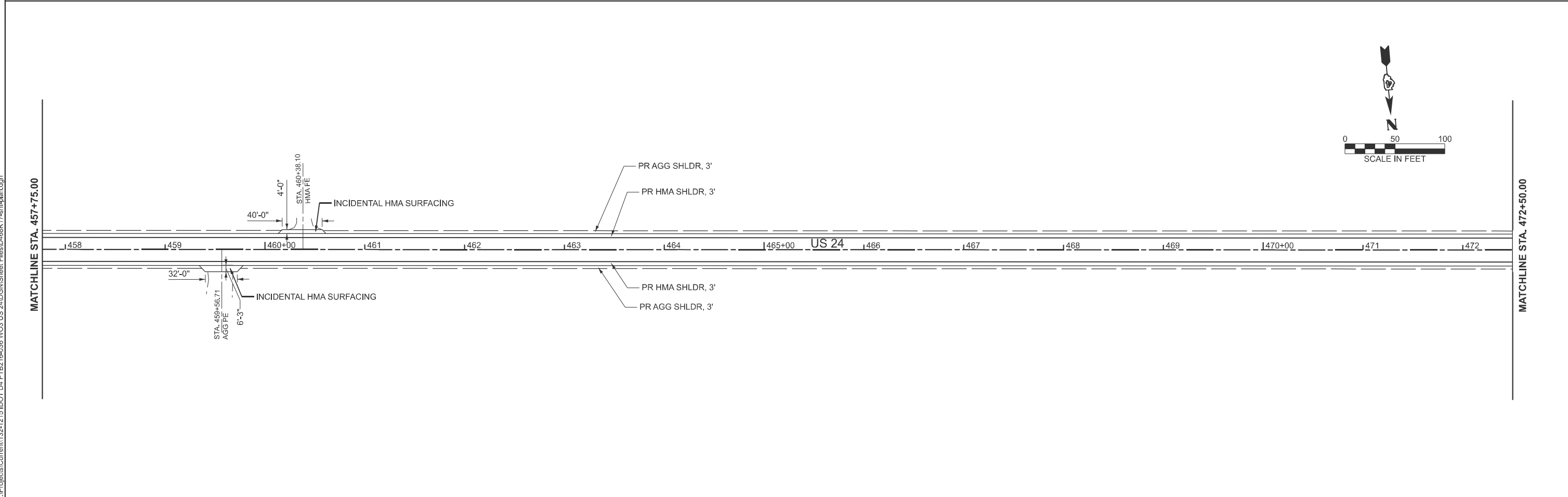
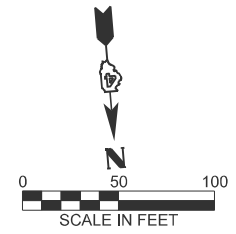
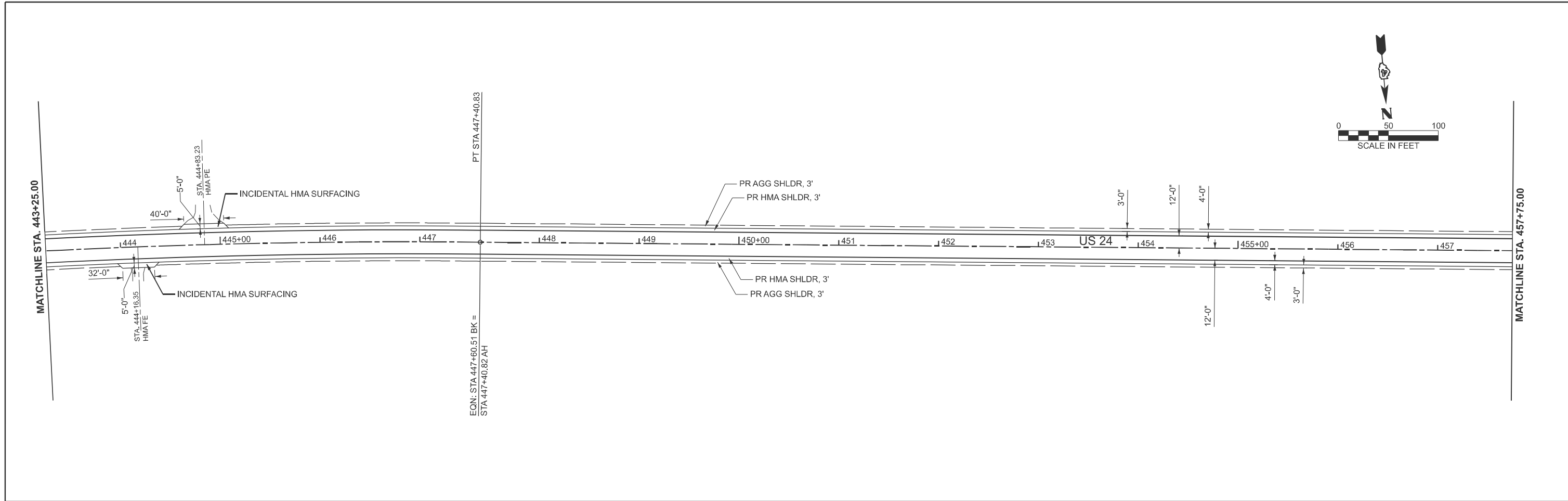

USER NAME = Cblackery	DESIGNED CB	REVISD -
	DRAWN CB	REVISD -
	CHECKED JG	REVISD -
PLOT DATE = 1/29/2026	DATE -	REVISD -

DESIGNED CB	REVISD -
DRAWN CB	REVISD -
CHECKED JG	REVISD -
DATE -	REVISD -

**STATE OF ILLINOIS  
 DEPARTMENT OF TRANSPORTATION**

**PLAN SHEET**

SCALE: 1"=50' SHEET 16 OF 20 SHEETS STA. 443+25.00 TO STA. 472+50.00

F.A.P. RTE.	SECTION	COUNTY	TOTAL SHEETS	SHEET NO.
VAR.	(17, 110, 111)RS-5; 18RS-6	FULTON	52	34
CONTRACT NO. 68K17				
ILLINOIS FED. AID PROJECT				

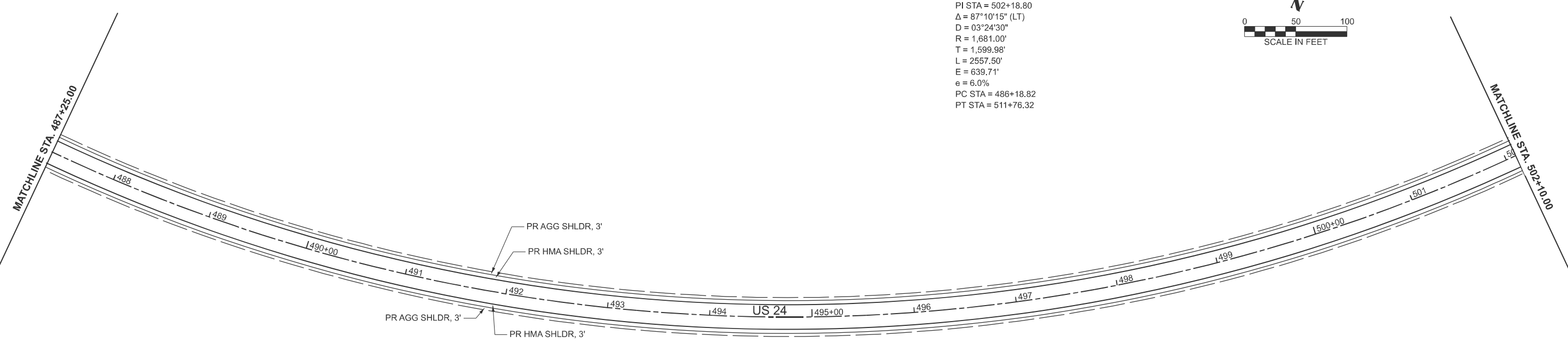
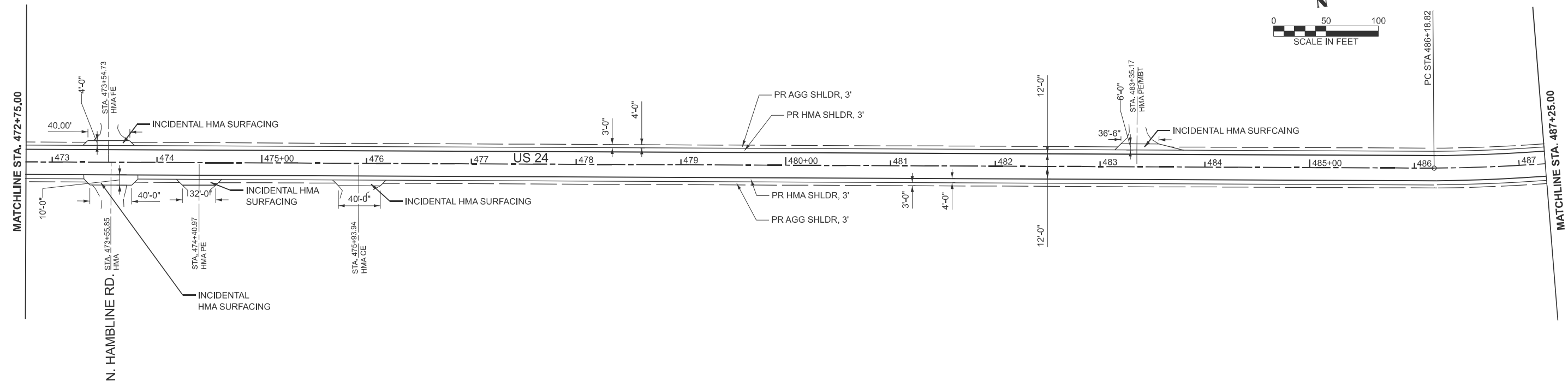

PR CURVE  
 PI STA = 502+18.80  
 $\Delta = 87^{\circ}10'15''$  (LT)  
 $D = 03^{\circ}24'30''$   
 $R = 1,681.00'$   
 $T = 1,599.98'$   
 $L = 2557.50'$   
 $E = 639.71'$   
 $e = 6.0\%$   
 PC STA = 486+18.82  
 PT STA = 511+76.32

MODEL: P:\C\20 - Plan 33 (Sheet)  
 FILE NAME: X:\Projects\Current\132-1215 IDOT D4 PTB216-036 W03 US 24\DGN\Sheet Files\468K17-sh-ham.dgn



USER NAME = Cblackerby	DESIGNED CB	REVISED -
	DRAWN CB	REVISED -
	CHECKED JG	REVISED -
PLOT DATE = 1/29/2026	DATE -	REVISED -

**STATE OF ILLINOIS  
 DEPARTMENT OF TRANSPORTATION**

**PLAN SHEET**

SCALE: 1"=50' SHEET 17 OF 20 SHEETS STA. 472+75.00 TO STA. 502+10.00

F.A.P. RTE.	SECTION	COUNTY	TOTAL SHEETS	SHEET NO.
VAR.	(17, 110, 111)RS-5; 18RS-6	FULTON	52	35
CONTRACT NO. 68K17				

ILLINOIS FED. AID PROJECT

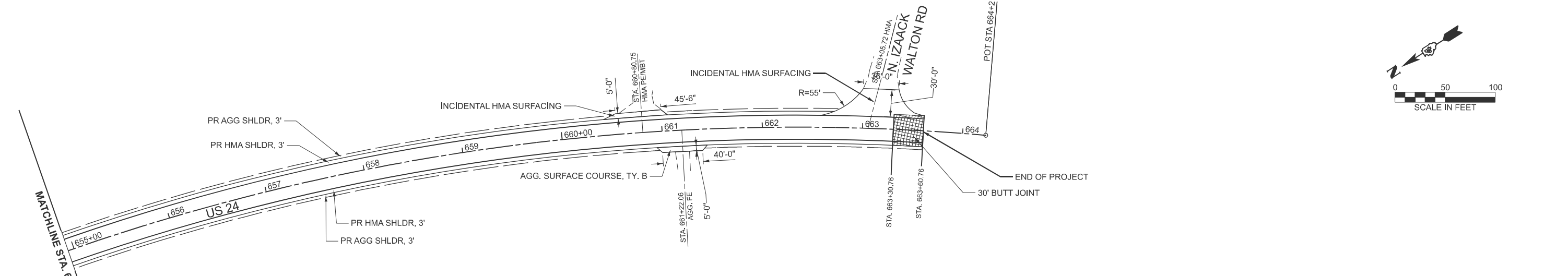
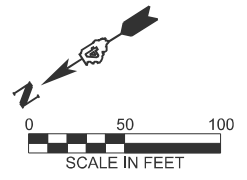
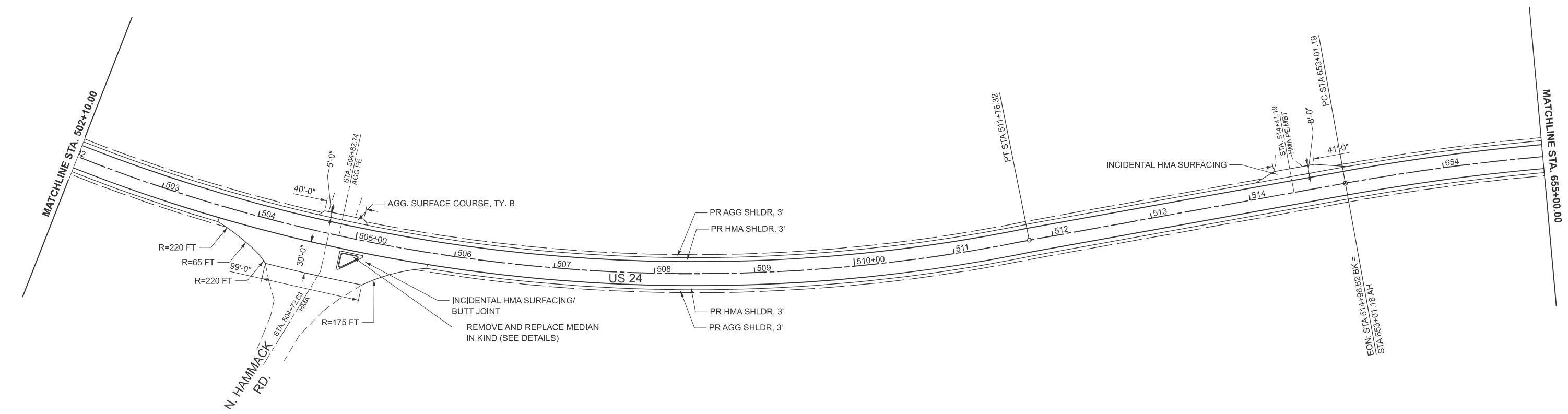
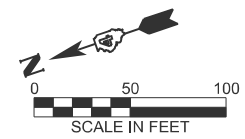

PR CURVE  
 PI STA = 658+74.60  
 $\Delta = 29^{\circ}10'05''$  (RT)  
 $D = 02^{\circ}35'59''$   
 $R = 2,203.87'$   
 $T = 573.41'$   
 $L = 1121.94$   
 $E = 73.37'$   
 $e = 4.75$   
 PC STA = 653+01.19  
 PT STA = 664+23.13

MODEL: P:\C120 - Plan 35 (Sheet)  
 FILE NAME: X:\Projects\Current\132-1215 IDOT D4 PTB216-036 I\03 US 24\DGN\Sheet Files\D468K17-sht-plan.dgn



USER NAME = Cblackerby	DESIGNED CB	REVISED -
	DRAWN CB	REVISED -
	CHECKED JG	REVISED -
PLOT DATE = 1/29/2026	DATE -	REVISED -

**STATE OF ILLINOIS  
 DEPARTMENT OF TRANSPORTATION**

**PLAN SHEET**

SCALE: 1"=50'      SHEET 18    OF 20    SHEETS    STA. 502+10.00    TO STA. 663+60.76

F.A.P. RTE.	SECTION	COUNTY	TOTAL SHEETS	SHEET NO.
VAR.	(17, 110, 111)RS-5; 18RS-6	FULTON	52	36
CONTRACT NO. 68K17				
ILLINOIS FED. AID PROJECT				

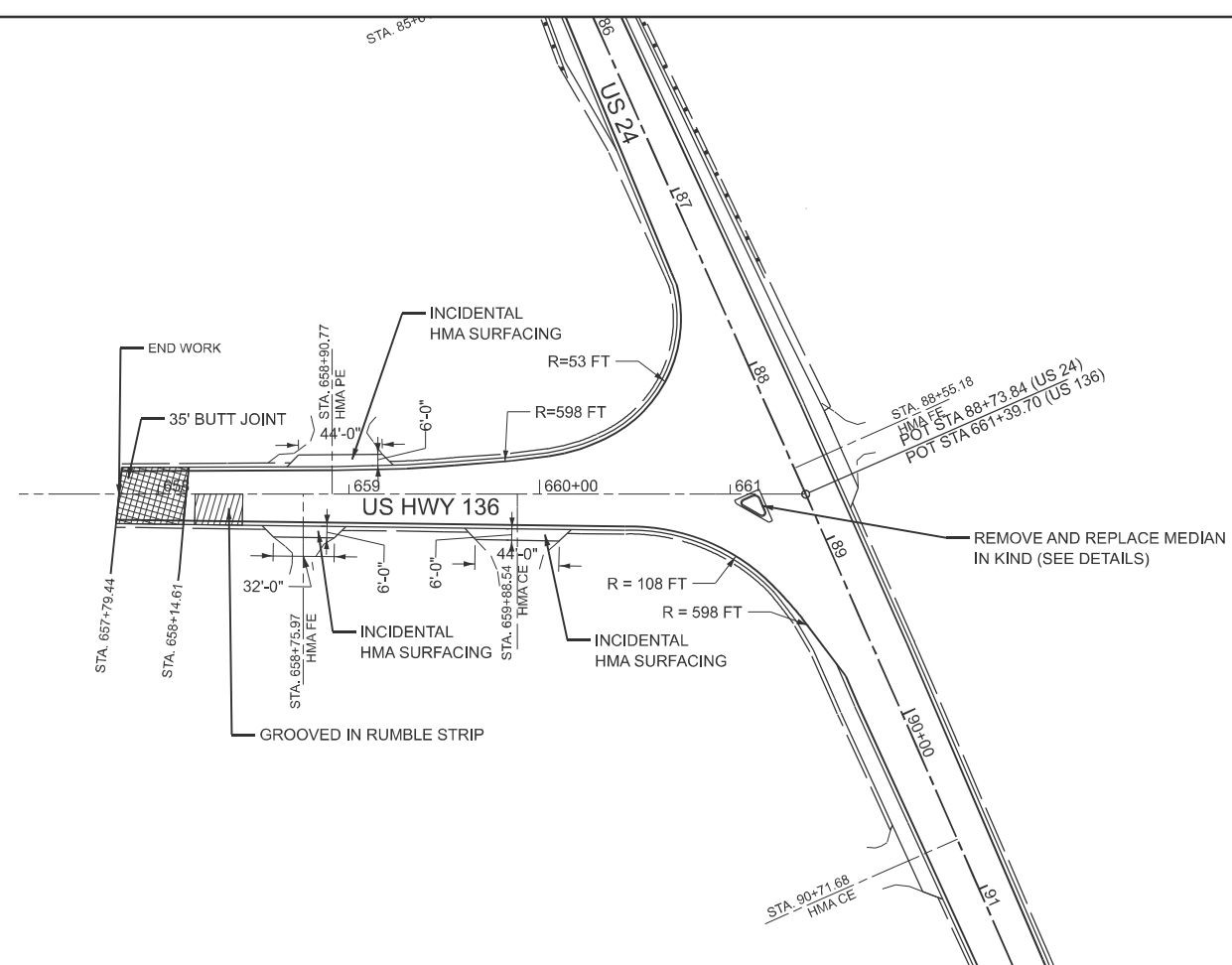
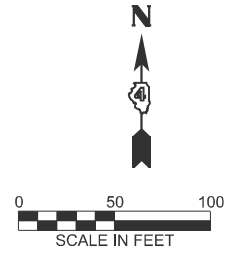

MODEL: EXCL - 106 N (Sheet)  
 FILE NAME: X:\Projects\Current\132-1215 IDOT D4 PTB216-036.W03 US 24\DWG\Sheet Files\468K17-sh-plan.dgn



USER NAME = Cblackerby	DESIGNED CB	REVISED -
	DRAWN CB	REVISED -
	CHECKED JG	REVISED -
PLOT DATE = 1/29/2026	DATE -	REVISED -

**STATE OF ILLINOIS  
DEPARTMENT OF TRANSPORTATION**

**PLAN SHEET**

SCALE: 1"=50'      SHEET 19 OF 20 SHEETS      STA. 657+79.44 TO STA. 661+39.70

F.A.P. RTE.	SECTION	COUNTY	TOTAL SHEETS	SHEET NO.
VAR.	(17, 110, 111)RS-5; 18RS-6	FULTON	52	37
CONTRACT NO. 68K17				
ILLINOIS FED. AID PROJECT				

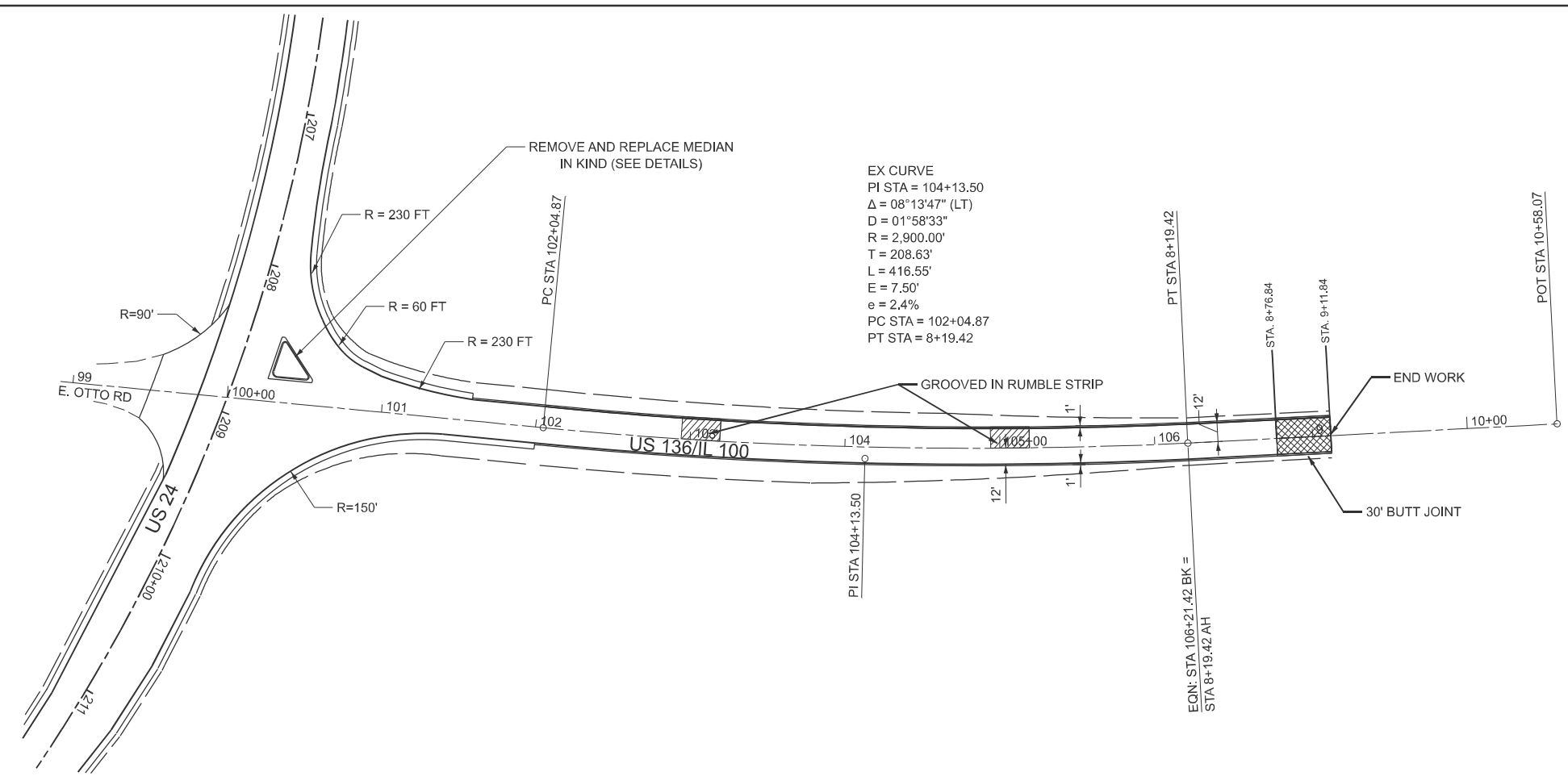
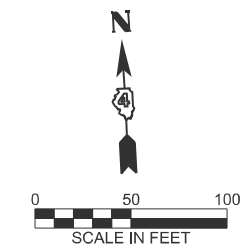

MODEL: EXCL9 - 136 N-1 (Sheet)  
 FILE NAME: X:\Projects\Current\132-1215 IDOT D4 PTB216-036.W03 US 24\DWG\Sheet Files\68K17-sh-Plan.dgn



USER NAME = Cblackerby	DESIGNED CB	REVISED -
	DRAWN CB	REVISED -
	CHECKED JG	REVISED -
PLOT DATE = 1/29/2026	DATE -	REVISED -

**STATE OF ILLINOIS  
DEPARTMENT OF TRANSPORTATION**

**PLAN SHEET**

SCALE: 1"=50'      SHEET 20    OF   20   SHEETS    STA. 100+00.00    TO STA. 9+11.84

F.A.P. RTE.	SECTION	COUNTY	TOTAL SHEETS	SHEET NO.
VAR.	(17, 110, 111)RS-5; 18RS-6	FULTON	52	38
CONTRACT NO. 68K17				
ILLINOIS FED. AID PROJECT				

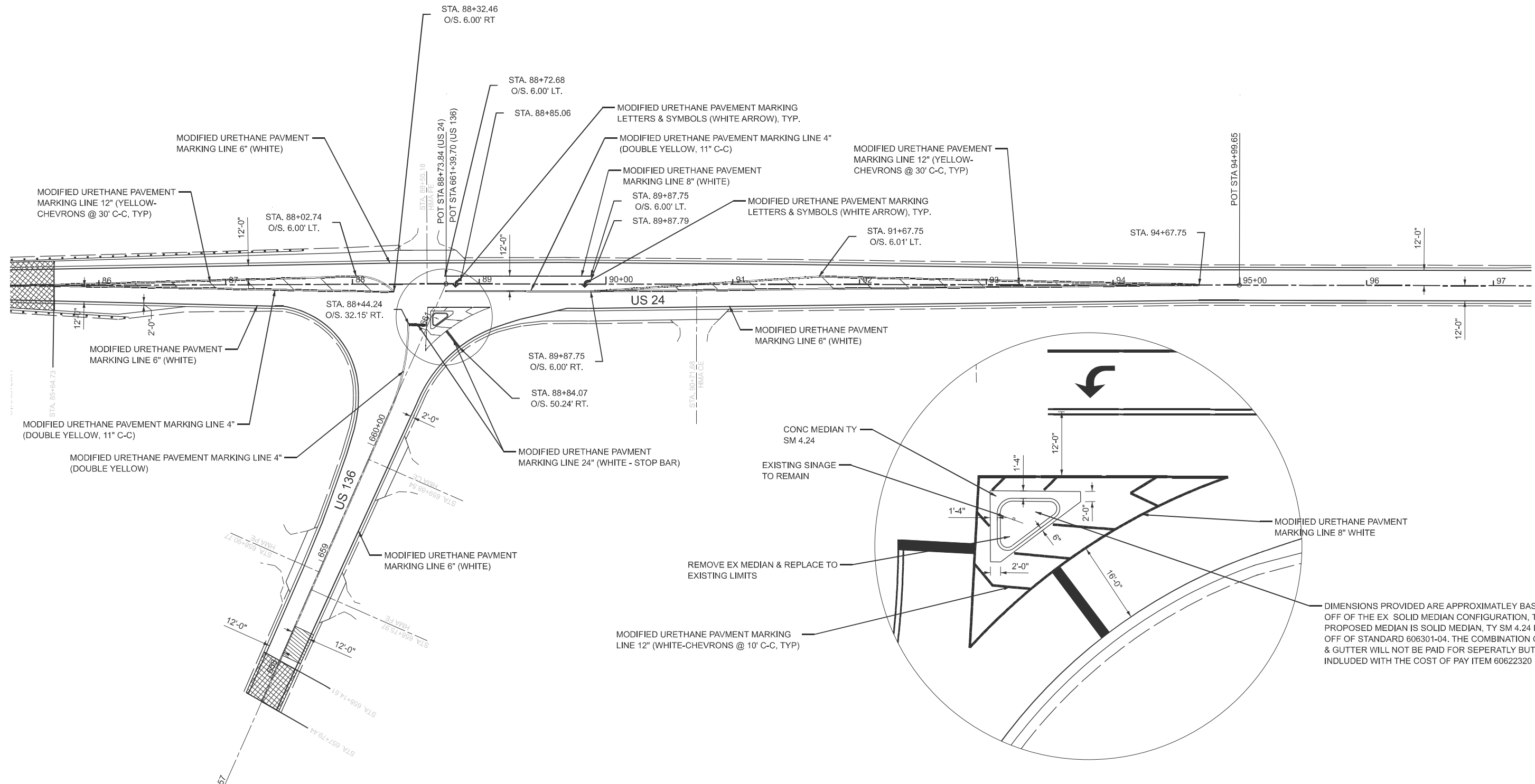
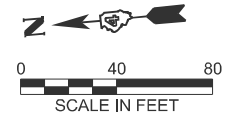

MODEL: P:\C17 - Plan 1 (Sheet)  
 FILE NAME: X:\Projects\Current\132-1215 IDOT D4 PTB216-036 W03 US 24\DWG\Sheet Files\68K17-sh1-details.dwg



USER NAME = Cblackery	DESIGNED CB	REVISED -
	DRAWN CB	REVISED -
	CHECKED JG	REVISED -
PLOT DATE = 1/29/2026	DATE -	REVISED -

**STATE OF ILLINOIS**  
**DEPARTMENT OF TRANSPORTATION**

<b>DETAILS</b>		
SCALE: 1"=40'	SHEET 1	OF 3 SHEETS
STA. 85+29.77		TO STA. 97+29.77

F.A.P. RTE.	SECTION	COUNTY	TOTAL SHEETS	SHEET NO.
VAR.	(17, 110, 111)RS-5; 18RS-6	FULTON	52	39
CONTRACT NO. 68K17				
ILLINOIS FED. AID PROJECT				

DIMENSIONS PROVIDED ARE APPROXIMATELY BASED OFF OF THE EX. SOLID MEDIAN CONFIGURATION, THE PROPOSED MEDIAN IS SOLID MEDIAN, TY SM 4.24 BASED OFF OF STANDARD 606301-04. THE COMBINATION CURB & GUTTER WILL NOT BE PAID FOR SEPERATLY BUT IS INCLUDED WITH THE COST OF PAY ITEM 60622320

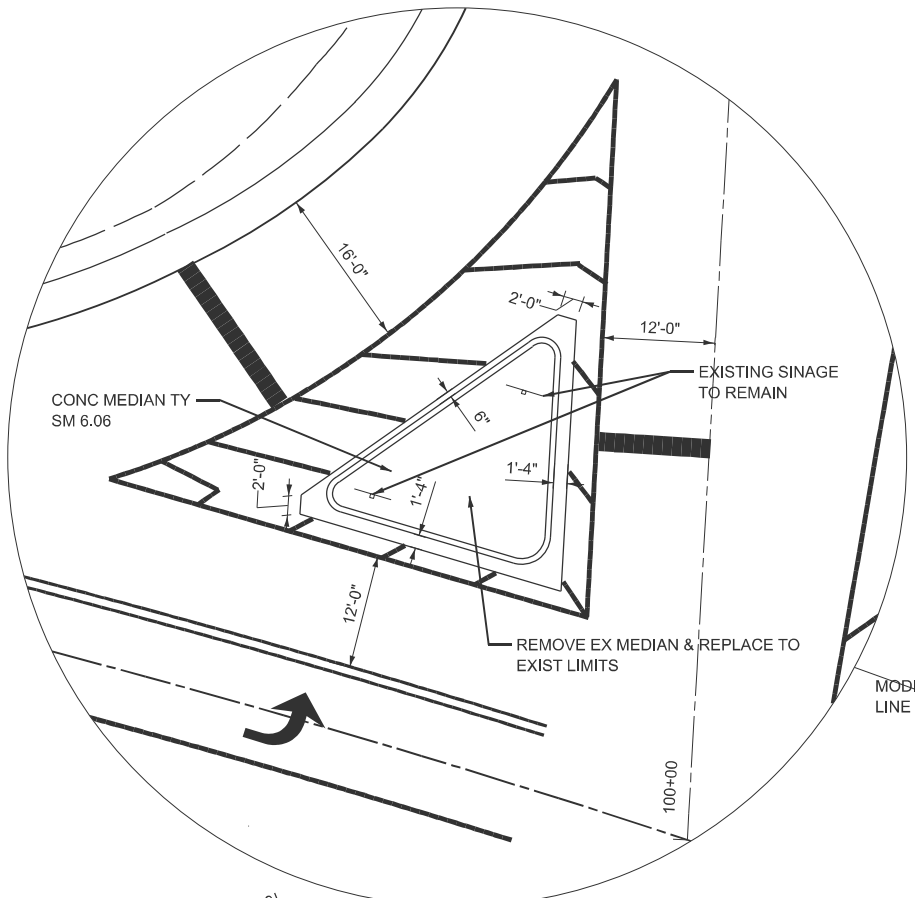
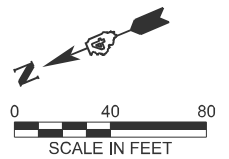

PC STA = 102+04.87  
PT STA = 8+19.42

MODIFIED URETHANE PAVEMENT MARKING LINE 24" (WHITE - STOP BAR)

DIMENSIONS PROVIDED ARE APPROXIMATELY BASED OFF OF THE EX SOLID MEDIAN CONFIGURATION, THE PROPOSED MEDIAN IS A SOLID MEDIAN, TY SM 6.06 BASED OFF OF STANDARD 606301-04. THE COMBINATION CURB & GUTTER WILL NOT BE PAID FOR SEPERATLY BUT IS INCLUDED WITH THE COST OF PAY ITEM 60622400

MODIFIED URETHANE PAVEMENT MARKING LINE 24" (WHITE - STOP BAR)

STA. 208+94.43  
O/S. 56.22' LT.

STA. 208+99.86  
O/S. 18.00' LT.

MODIFIED URETHANE PAVMENT MARKING LINE 8" WHITE

MODIFIED URETHANE PAVMENT MARKING LINE 12" (WHITE CHEVRONS @ 10'C-C, TYP)

STA. 209+57.55  
O/S. 18.00' LT

STA. 209+89.94  
O/S. 6.00' LT.

MODIFIED URETHANE PAVEMENT MARKING LINE 8" (WHITE)

STA. 210+69.15  
O/S. 18.00' LT.

STA. 210+57.22  
O/S. 6.00' LT.

STA. 211+00.83  
O/S. 6.00' LT.

STA. 211+99.88

STA. 205+75.18  
O/S. 8.00' RT

STA. 206+66.95  
O/S. 6.00' LT.

STA. 208+72.53  
O/S. 6.00' LT.

STA. 208+72.56  
O/S. 6.00' RT

STA. 206+98.47  
O/S. 6.00' RT

MODIFIED URETHANE PAVEMENT MARKING LINE 8" (WHITE)

MODIFIED URETHANE PAVEMENT MARKING LINE 12" (YELLOW CHEVRONS @ 30' C-C, TYP)

STA. 209+31.78  
O/S. 6.00' LT.

STA. 209+31.75  
O/S. 6.00' RT.

STA. 211+01.10  
O/S. 6.00' RT.

MODIFIED URETHANE PAVEMENT MARKING LINE 4" (DOUBLE YELLOW)

MODIFIED URETHANE PAVEMENT MARKING LINE 4" (DOUBLE YELLOW)

MODIFIED URETHANE PAVEMENT MARKING LINE 12" (YELLOW CHEVRONS @ 30' C-C, TYP)

MODIFIED URETHANE PAVEMENT MARKING LETTERS & SYMBOLS (WHITE ARROW, TYP)

PR CURVE  
PI STA = 209+49.61  
Δ = 47°46'54" (RT)  
D = 05°00'00"  
R = 1,145.91'  
T = 507.58'  
L = 955.63  
E = 107.38'  
e = 7.1%  
PC STA = 204+42.03  
PT STA = 213+97.66

E. OTTORD

MODEL: P:\C118 - Plan 2 (Sheet) FILE NAME: X:\Projects\Current\1132-1215 IDOT D4 PTB216-036 W03 US 24\Drawn\Sheet Files\68K17-sh-detailed.dgn



USER NAME = Cblackery	DESIGNED CB	REVISED -
	DRAWN CB	REVISED -
	CHECKED JG	REVISED -
PLOT DATE = 1/29/2026	DATE -	REVISED -

**STATE OF ILLINOIS  
DEPARTMENT OF TRANSPORTATION**

**DETAILS**

SCALE: 1"=40' SHEET 2 OF 3 SHEETS STA. 202+69.26 TO STA. 214+69.26

F.A.P. RTE.	SECTION	COUNTY	TOTAL SHEETS	SHEET NO.
VAR.	(17, 110, 111)RS-5; 18RS-6	FULTON	52	40
CONTRACT NO. 68K17				
ILLINOIS FED. AID PROJECT				

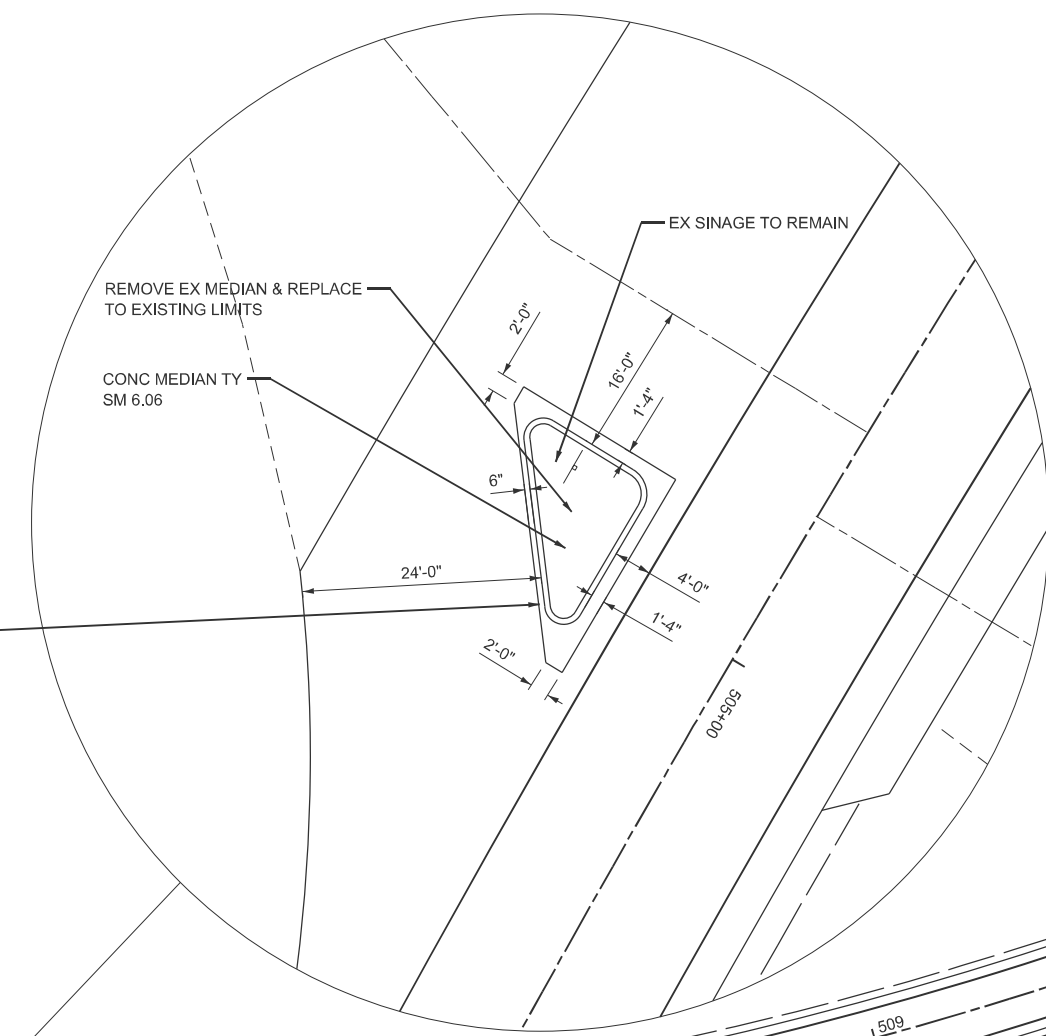
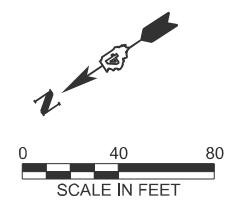

DIMENSIONS PROVIDED ARE APPROXIMATELY BASED OFF OF THE EX SOLID MEDIAN CONFIGURATION, THE PROPOSED MEDIAN IS SOLID MEDIAN, TY SM 6.06 BASED OFF OF STANDARD 606301-04. THE COMBINATION CURB & GUTTER WILL NOT BE PAID FOR SEPERATLY BUT IS INCLUDED WITH THE COST OF PAY ITEM 60622400

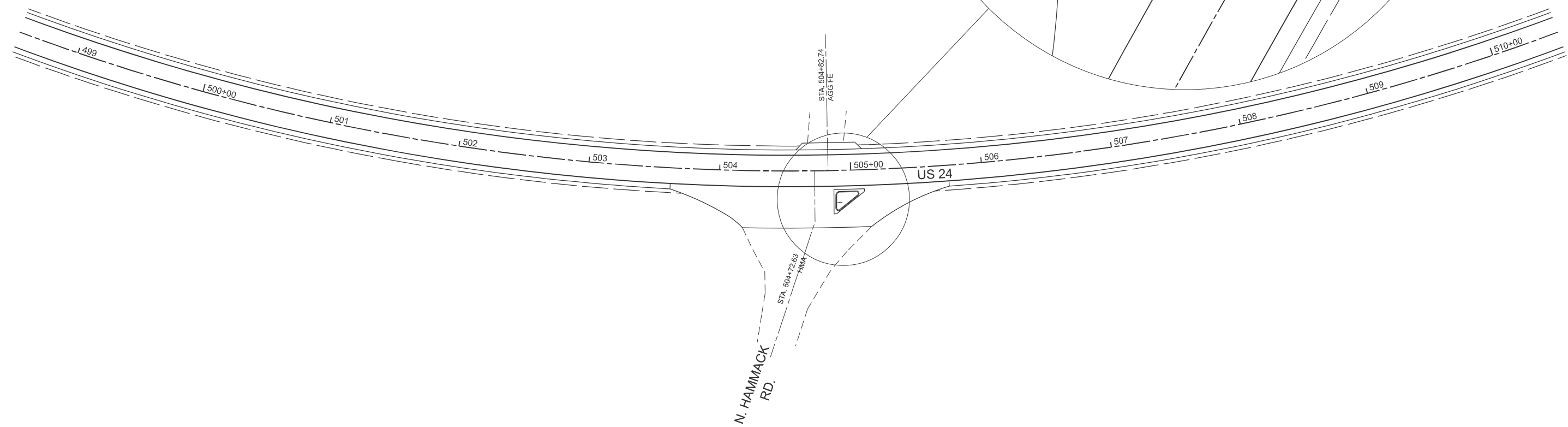

MODEL: P:\C119 - Plan 3 (Sheet)  
 FILE NAME: X:\Projects\Current\1132-1215 IDOT D4 PTB216-036.W03 US 24\DWG\Sheet Files\068K17-sh1-details.dgn



USER NAME = Cblackery	DESIGNED CB	REVISED -
	DRAWN CB	REVISED -
	CHECKED JG	REVISED -
PLOT DATE = 1/29/2026	DATE -	REVISED -

**STATE OF ILLINOIS  
 DEPARTMENT OF TRANSPORTATION**

<b>DETAILS</b>	
SCALE: 1"=40'	SHEET 3 OF 3 SHEETS
STA. 498+52.85	TO STA. 510+52.85

F.A.P. RTE.	SECTION	COUNTY	TOTAL SHEETS	SHEET NO.
VAR.	(17, 110, 111)RS-5; 18RS-6	FULTON	52	41
CONTRACT NO. 68K17				
ILLINOIS FED. AID PROJECT				

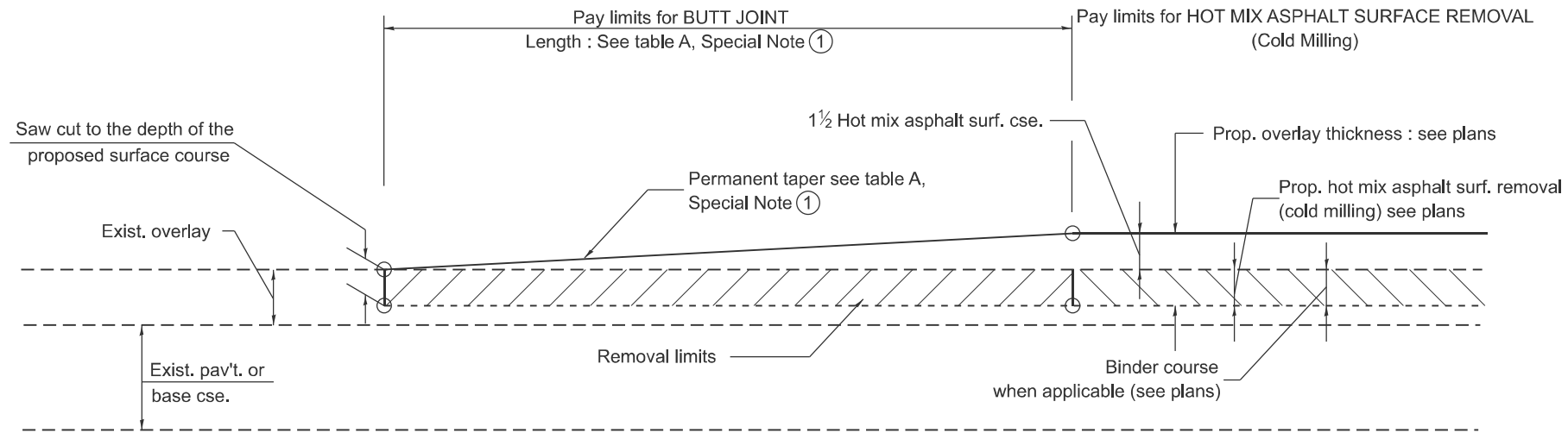

**CASE 1 : WITH HOT MIX ASPHALT SURFACE REMOVAL (COLD MILLING)**

**TABLE A  
TAPER RATES**

SPECIAL NOTE NUMBER	ELEMENT	MAINLINE INTERSTATES & 4-LANE EXPRESSWAYS	ALL OTHERS
①	BUTT JOINT TAPER RATE	1:480	1:240
②	TEMPORARY RAMP TAPER RATE	1:80	1:40

**GENERAL NOTES**

1. The work shall be done in accordance with Article 406.08 and the Special Provision for Butt Joints.
2. The pavement surface to be removed may be either bituminous or P.C. concrete. The work shall be performed in accordance with Article 440.04 and the Special Provisions for Butt Joints.
3. The saw cut joints shall be primed just prior to the placing of bituminous material. The work will be in accordance with the applicable portions of Article 406.05.
4. The length of butt joint is based on the taper rate times change in cold milling depth within the butt joint pay limits, unless otherwise indicated.
5. Temporary ramps are paid for separately and not included in the cost of the butt joints.

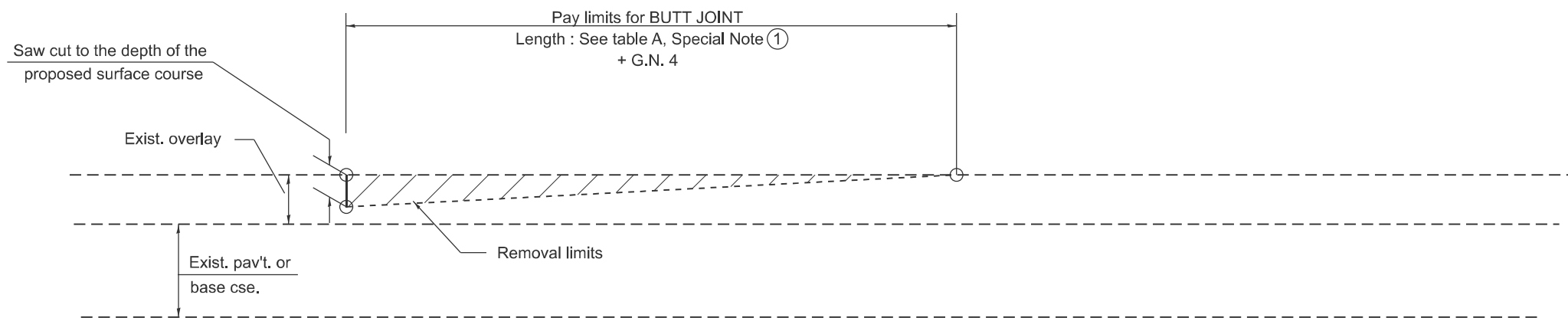

**CASE 2 : NO HOT MIX ASPHALT SURFACE REMOVAL (COLD MILLING)**

All dimensions are in inches unless otherwise noted.

MODEL: D4-06101-01  
FILE NAME: c:\p\work\pav\illinois.gov\thomas.cox\illinois.gov\10559441D4-06101.dgn

USER NAME = thomas.cox	DESIGNED -	REVISED -
	DRAWN -	REVISED -
	CHECKED -	REVISED -
PLOT DATE = 9/17/2025	DATE -	REVISED -

**STATE OF ILLINOIS  
DEPARTMENT OF TRANSPORTATION**

**BUTT JOINTS**

SCALE: NOT TO SCALE SHEET 000 1 OF 3 SHEETS STA. TO STA.

F.A.P. RTE.	SECTION	COUNTY	TOTAL SHEETS	SHEET NO.
VAR.	(17, 110, 111)RS-5; 18RS-6	FULTON	52	42
DISTRICT 4 STANDARD NO. 406101		CONTRACT NO. 68K17		
ILLINOIS FED. AID PROJECT				

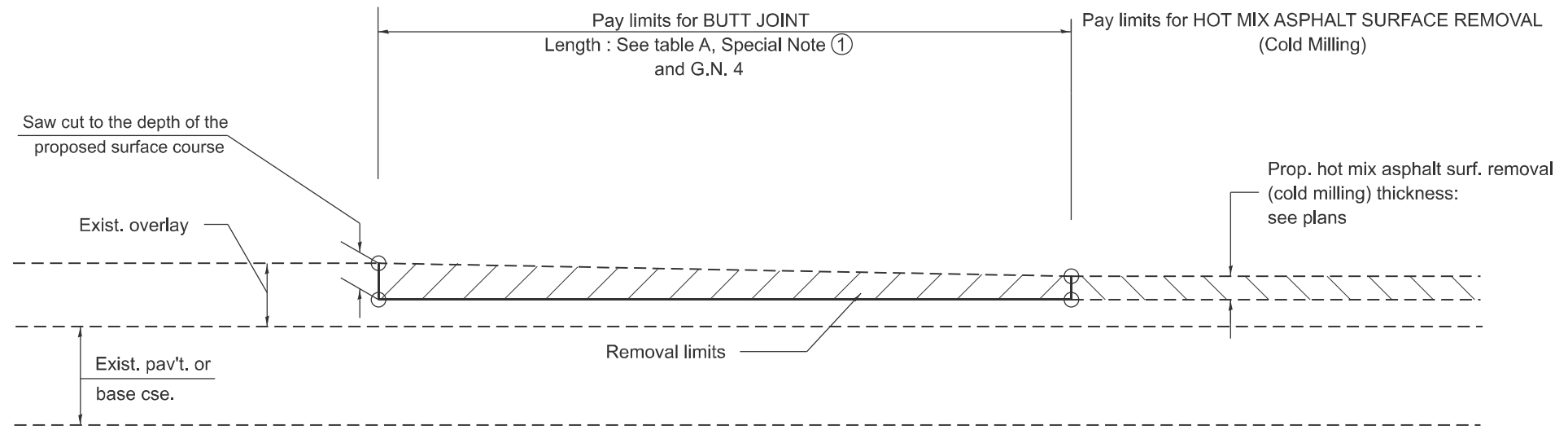

**CASE 3 : HOT MIX ASPHALT SURFACE REMOVAL (COLD MILLING)  
TIE-IN TO EXISTING BITUMINOUS TAPER**

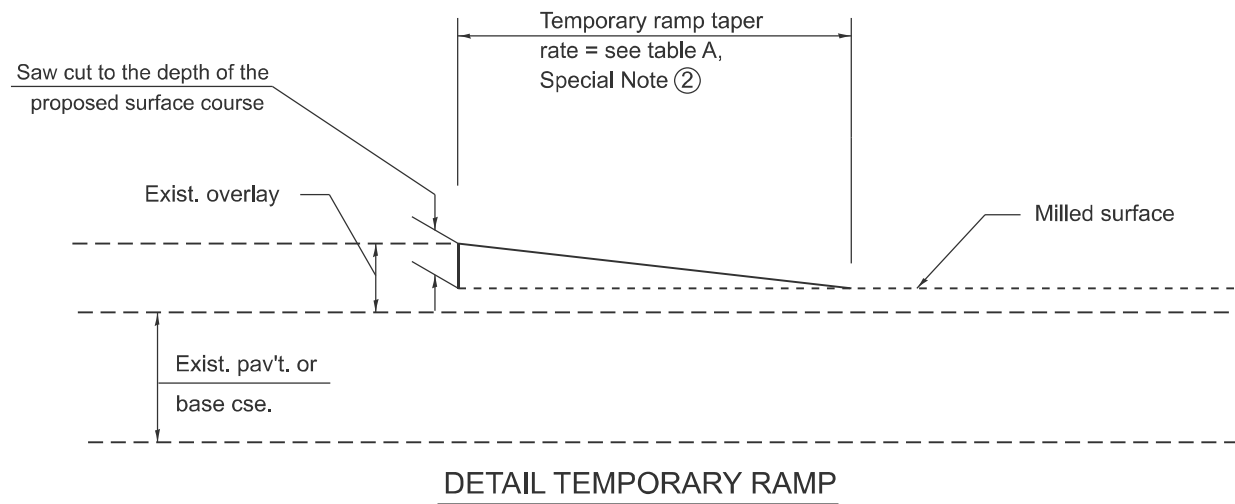

All dimensions are in inches unless otherwise noted.

MODEL: D4-06101-02  
FILE NAME: c:\p\work\pav\illinois.gov\thomas.cox\illinois.gov\td\0559441D4-06101.dgn

USER NAME = thomas.cox	DESIGNED -	REVISED -
	DRAWN -	REVISED -
	CHECKED -	REVISED -
PLOT DATE = 9/17/2025	DATE -	REVISED -

**STATE OF ILLINOIS  
DEPARTMENT OF TRANSPORTATION**

**BUTT JOINTS**

SCALE: NOT TO SCALE SHEET 000 2 OF 3 SHEETS STA. TO STA.

F.A.P. RTE.	SECTION	COUNTY	TOTAL SHEETS	SHEET NO.
VAR.	(17, 110, 111)RS-5; 18RS-6	FULTON	52	43
DISTRICT 4 STANDARD NO. 406101			CONTRACT NO. 68K17	
ILLINOIS FED. AID PROJECT				

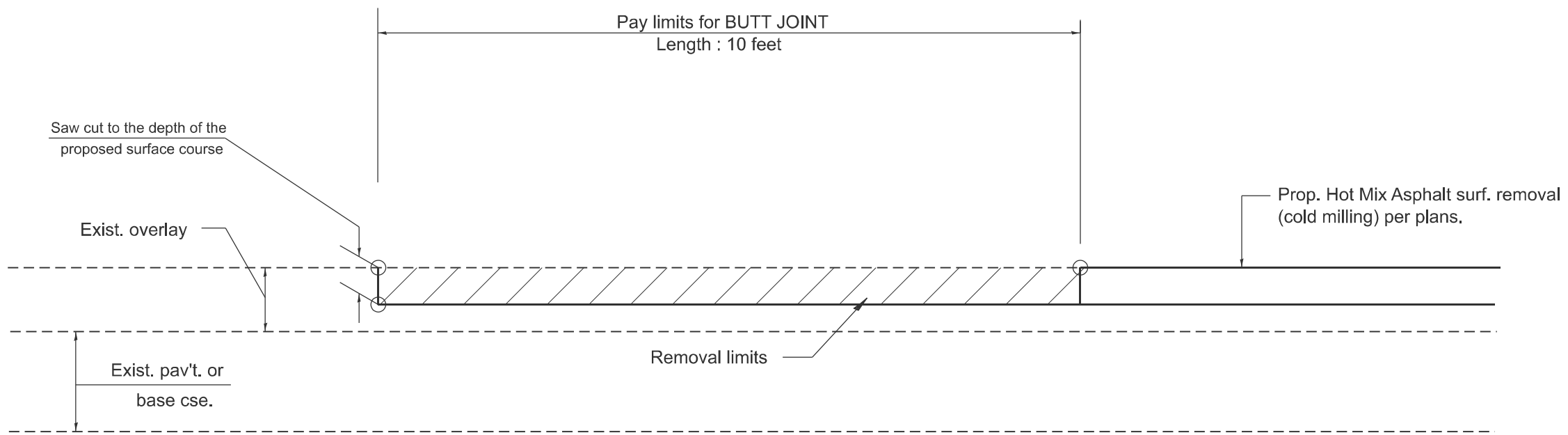

**CASE 4 : SINGLE LIFT OVERLAY WITH EQUIVALENT DEPTH**  
**HOT MIX ASPHALT SURFACE REMOVAL (COLD MILLING)**  
**TIE-IN TO EXISTING BITUMINOUS TAPER**

MODEL: D4-06101-03  
 FILE NAME: c:\p\work\pwr\illinois.gov\thomas.cox\illinois.gov\id1055944\D4-06101.dgn

All dimensions are in inches unless otherwise noted.

USER NAME = thomas.cox	DESIGNED -	REVISED -
	DRAWN -	REVISED -
	CHECKED -	REVISED -
PLOT DATE = 9/17/2025	DATE -	REVISED -

**STATE OF ILLINOIS**  
**DEPARTMENT OF TRANSPORTATION**

**BUTT JOINTS**

SCALE: NOT TO SCALE SHEET 000 3 OF 3 SHEETS STA. TO STA.

F.A.P. RTE.	SECTION	COUNTY	TOTAL SHEETS	SHEET NO.
VAR. (17, 110, 111)	RS-5; 18RS-6	FULTON	52	44
DISTRICT 4 STANDARD NO. 406101			CONTRACT NO. 68K17	
ILLINOIS FED. AID PROJECT				

DESIGNER NOTES:  
 1. THIS DRAWING REPLACES STATE STANDARD 406201  
 MODEL: D4-406201-2- DESIGNER SHOULD CONSULT CHAPTER 49 OF THE BDE MANUAL  
 FILE NAME: c:\pdx\_wor\k\pdx\illinois.gov\thomas.cox\10559441D4-406201.dgn

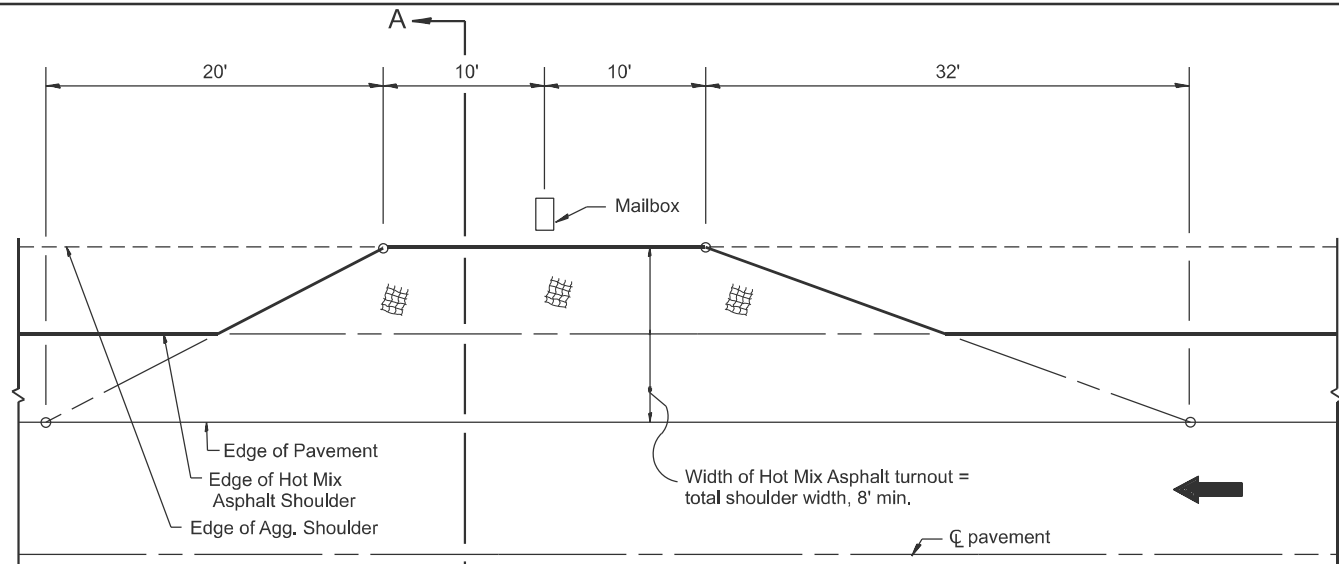

**METHOD "T"**  
 Typical Application

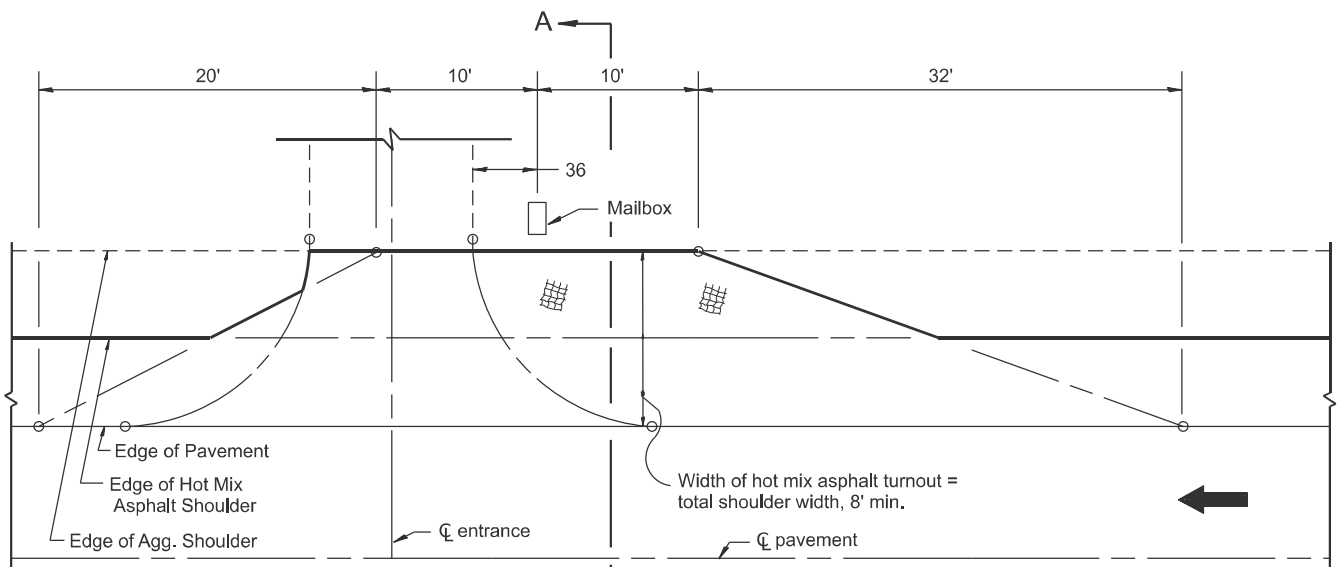

**METHOD "N"**  
 Mailbox on near side of entrance

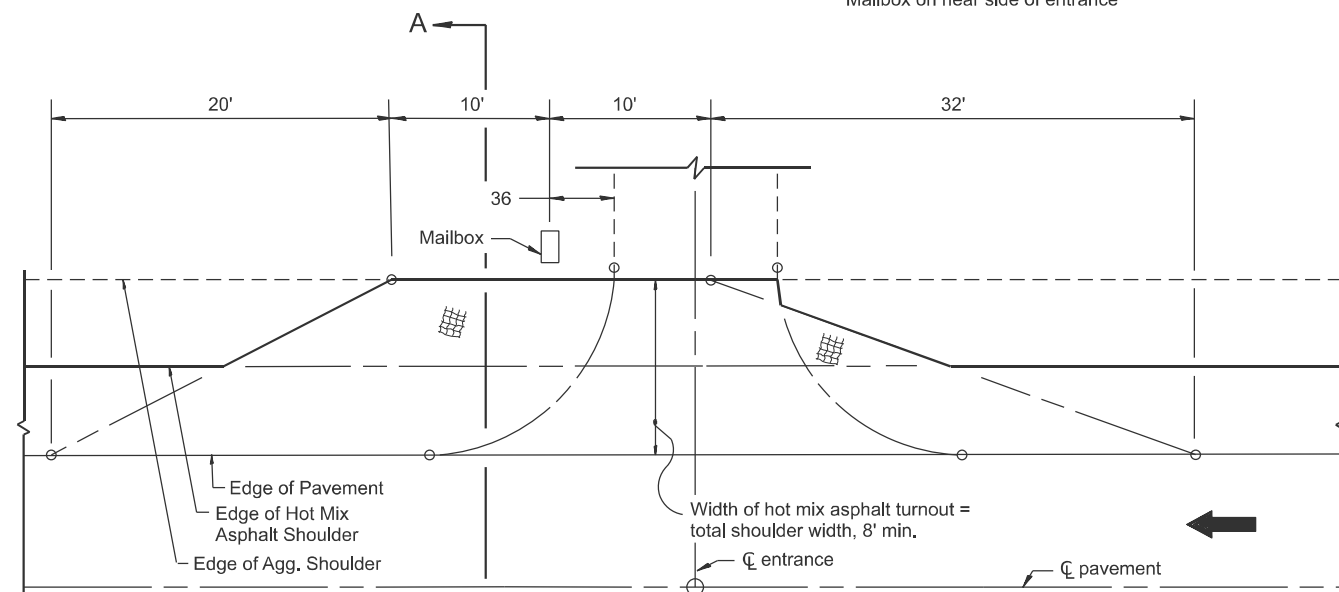

**METHOD "F"**  
 Mailbox on far side of entrance

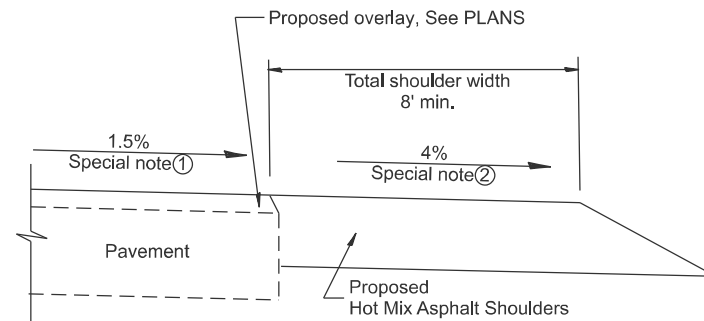

**SECTION A-A**

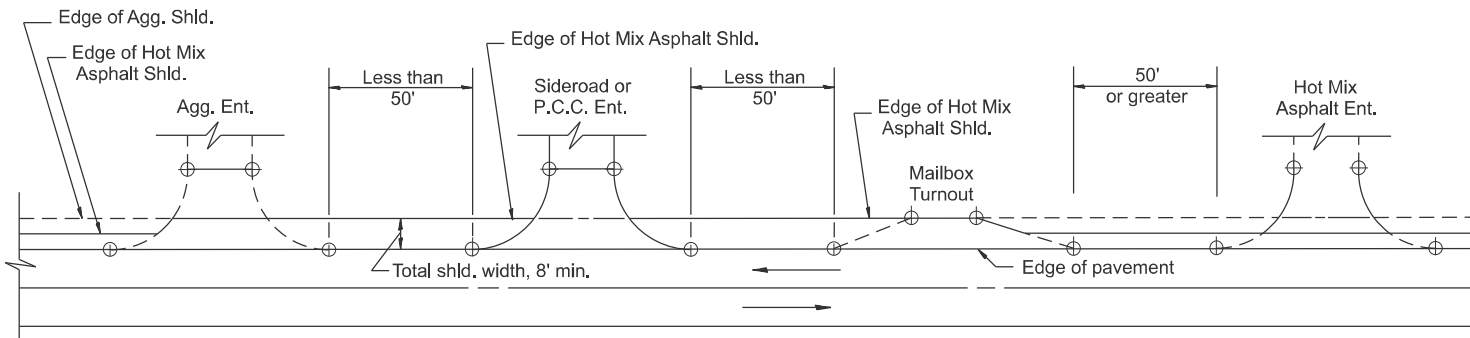

**DETAIL A**

SHOULDER TREATMENT FOR CLOSELY SPACED SIDEROADS, ENTRANCES, AND/OR MAILBOX TURNOUTS

**GENERAL NOTES**

- Mailbox turnouts shall slope away from the pavement edge at a rate equal to the shoulder slope. See SECTION A-A.
- The total shoulder width, 8' minimum, shall be paved between sideroads entrances and/or mailbox turnouts at locations where the distance between radius or taper control points is less than 50'. See DETAIL A.
- Mailboxes shall be mounted such that the face of the mailbox is 6 to 12 and the post a minimum of 24 from the edge of the turnout surfacing.

**SPECIAL NOTES**

- The mainline pavement cross-slope is 1.5% for tangent alignment. See PLANS for cross-slope on superelevated horizontal curves.
- The shoulder slope shall control the turnout slope. The standard cross-slope is 4% for tangent alignment. Through superelevated curves, the maximum pavement-shoulder breakover should not be greater than 10% for shoulders 6' and wider and 12% for shoulders 4' and less. Where 12 paved shoulders are provided, the breakover should be at the edge of the paved shoulder rather than at the pavement edge.

All dimensions are in inches unless otherwise noted.

USER NAME = thomas.cox	DESIGNED -	REVISED -
	DRAWN -	REVISED -
	CHECKED -	REVISED -
PLOT DATE = 9/17/2025	DATE -	REVISED -

**STATE OF ILLINOIS**  
**DEPARTMENT OF TRANSPORTATION**

**MAILBOX TURNOUTS FOR "3R" PROJECTS**

SCALE: NOT TO SCALE SHEET 000 OF SHEETS STA. TO STA.

F.A.P. RTE.	SECTION	COUNTY	TOTAL SHEETS	SHEET NO.
VAR. (17, 110, 111)RS-5; 18RS-6		FULTON	52	45
DISTRICT 4 STANDARD NO. 406201			CONTRACT NO. 68K17	
ILLINOIS FED. AID PROJECT				

DESIGNER NOTES:  
 1. DESIGNER SHOULD CONSULT CHAPTER 53 OF THE BDE MANUAL.  
 2. THIS CADD STANDARD IS FOR PPP PROJECTS.  
 MODEL: D:\406402\406402.dgn  
 FILE NAME: C:\Users\David.broviak\OneDrive - State of Illinois\PD&P\General notes\_Specials\_CADD\_Details\D-406402.dgn

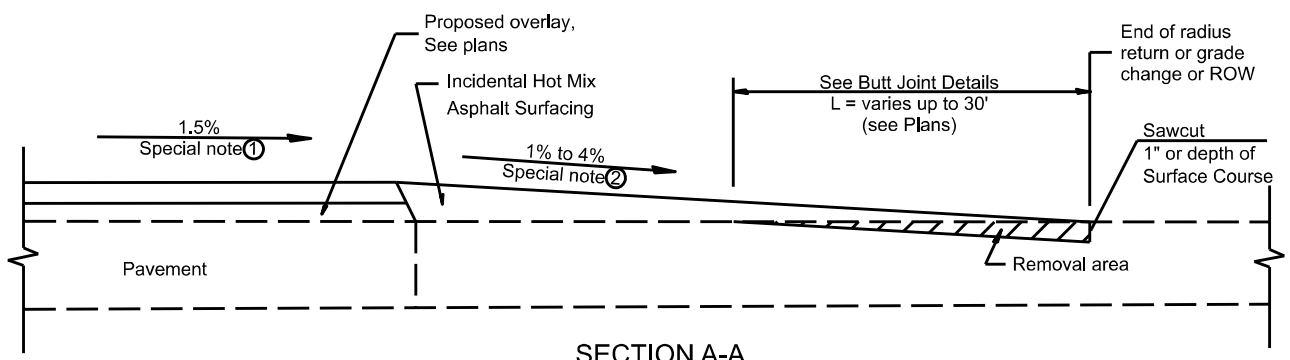

SECTION A-A  
 EXISTING PCC OR HOT MIX ASPHALT SIDEROAD

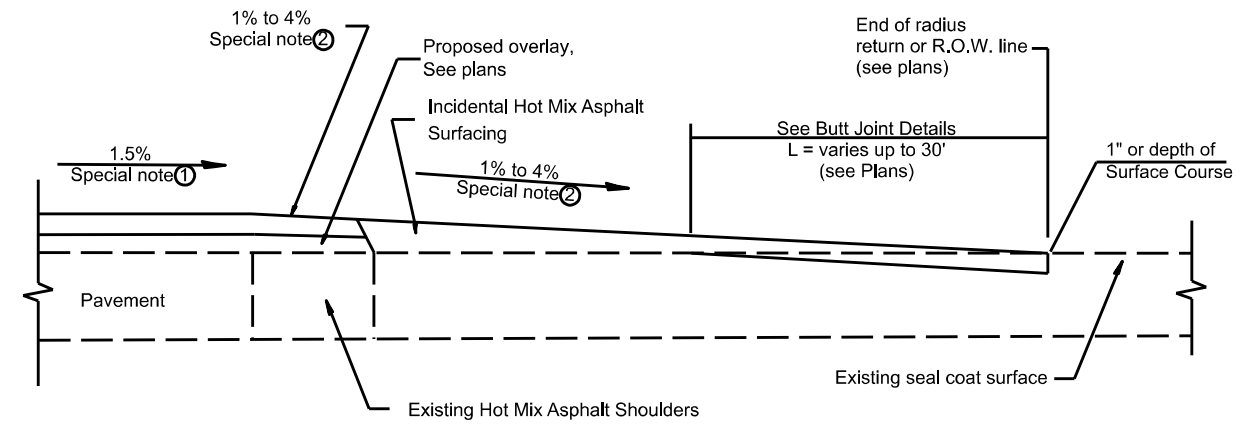

SECTION A-A  
 EXISTING SEAL COAT SIDEROAD

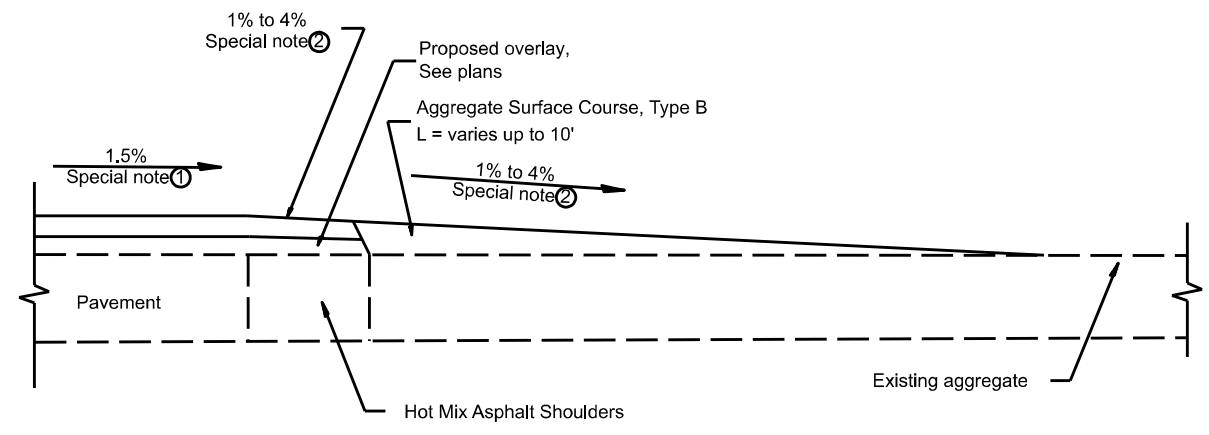

SECTION A-A  
 EXISTING AGGREGATE SIDEROAD

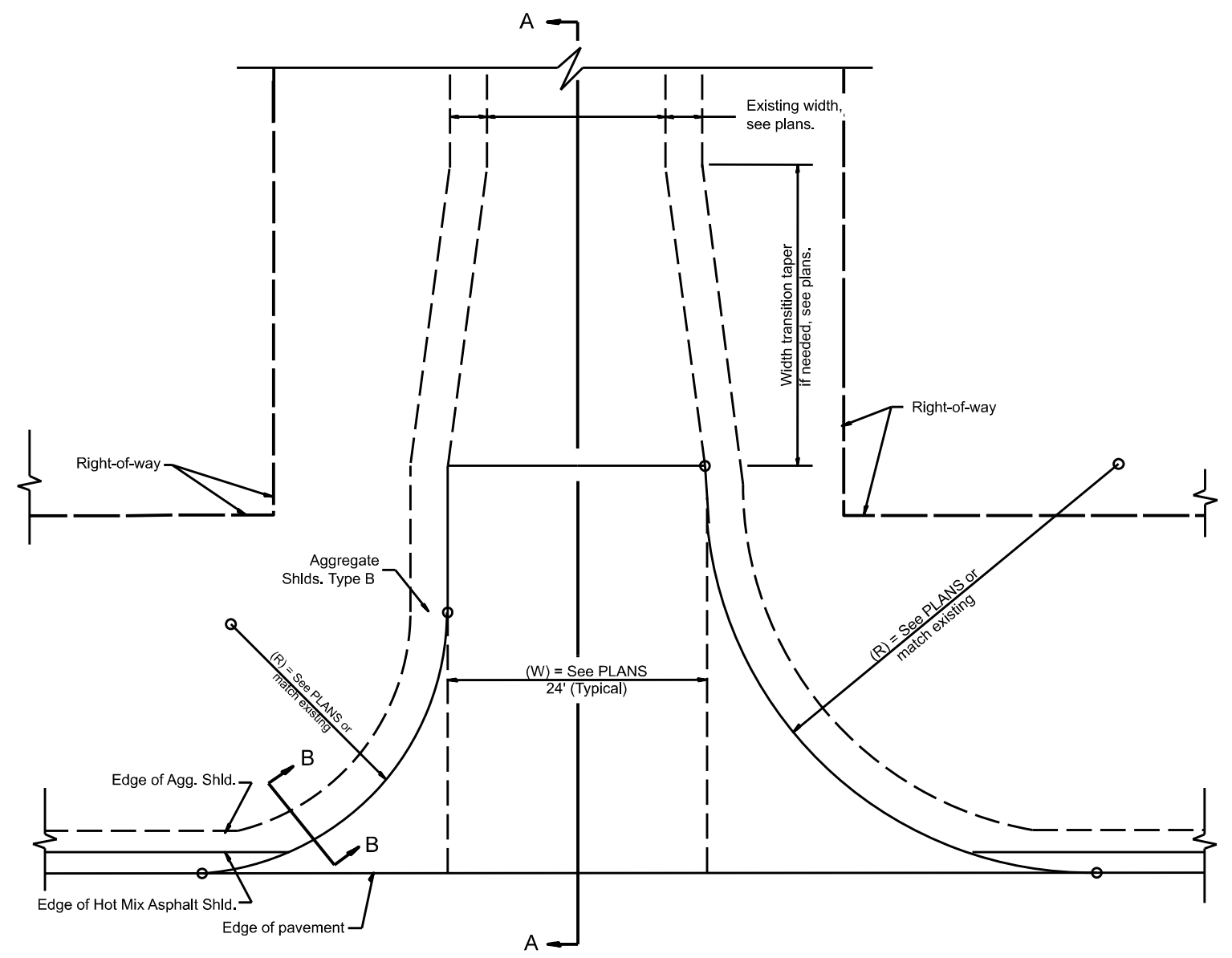

PLAN

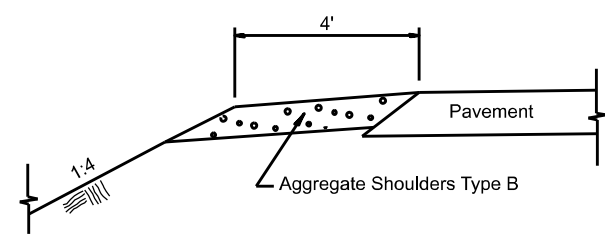

SECTION B-B  
 SIDEROAD SHOULDER TREATMENT

**SPECIAL NOTES**

- ① The mainline pavement cross-slope is 1.5% for tangent alignment. See Plans for cross-slope on superelevated horizontal curves.
- ② The sideroad profile should drain away from the mainline at 1% to 4% for 50' to 100', or as a minimum to the end of the radius return. When the sideroad is on the high side of a mainline superelevated curve, -2% maximum should be provided in order to minimize breakover at the pavement edge. See plans for sideroad profiles.

All dimensions are in inches unless otherwise noted.

USER NAME = david.broviak	DESIGNED -	REVISED -
	DRAWN -	REVISED -
	CHECKED -	REVISED -
PLOT DATE = 1/18/2026	DATE -	REVISED -

**STATE OF ILLINOIS**  
**DEPARTMENT OF TRANSPORTATION**

**RURAL SIDEROADS FOR "PPP" PROJECTS**

SCALE: NOT TO SCALE SHEET 000 OF SHEETS STA. TO STA.

F.A.P. RTE.	SECTION	COUNTY	TOTAL SHEETS	SHEET NO.
(17, 110, 111)RS-5, 18RS-6		FULTON	52	46
DISTRICT 4 DETAIL NO. 406402			CONTRACT NO. 68K17	
ILLINOIS FED. AID PROJECT				



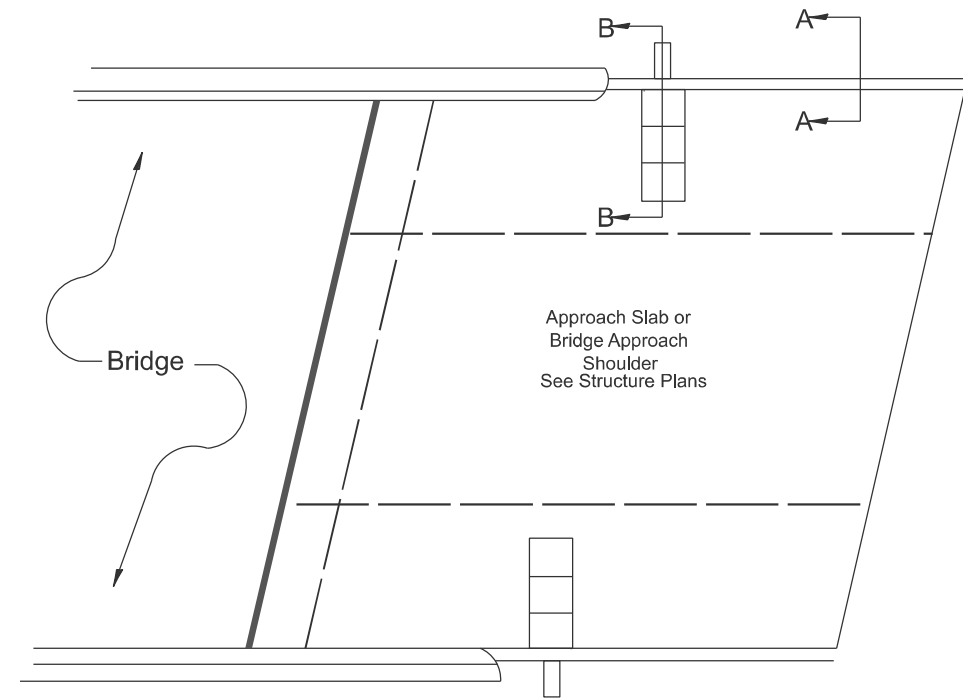
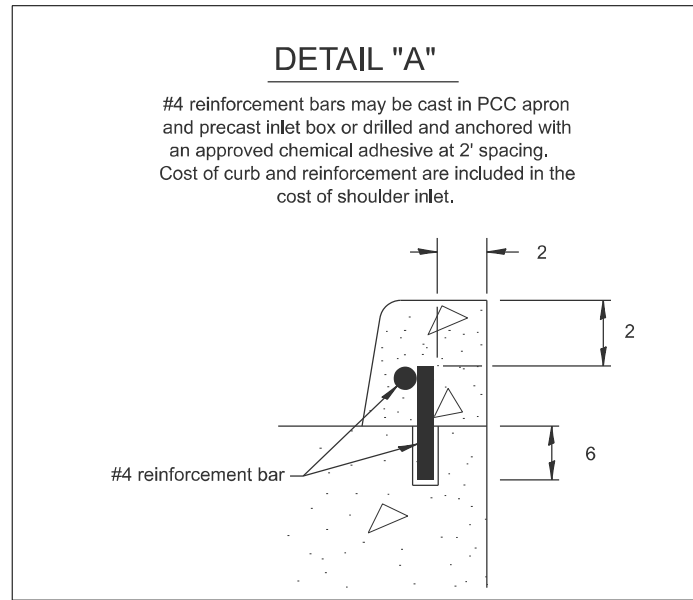

**PLAN VIEW**  
**APPROACH SLAB OR SHOULDER PLACEMENT**

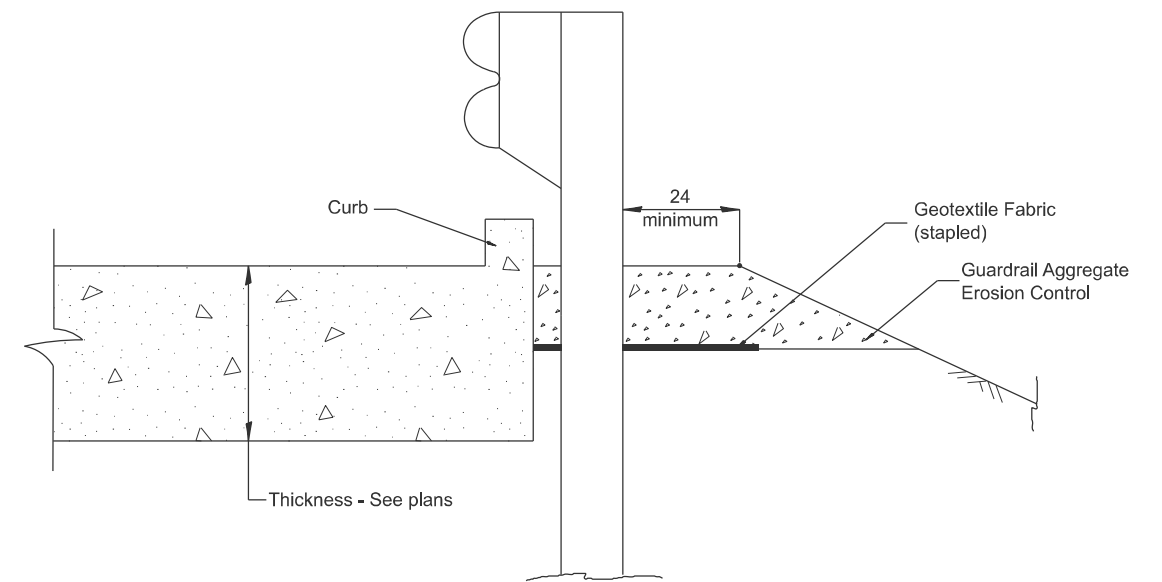
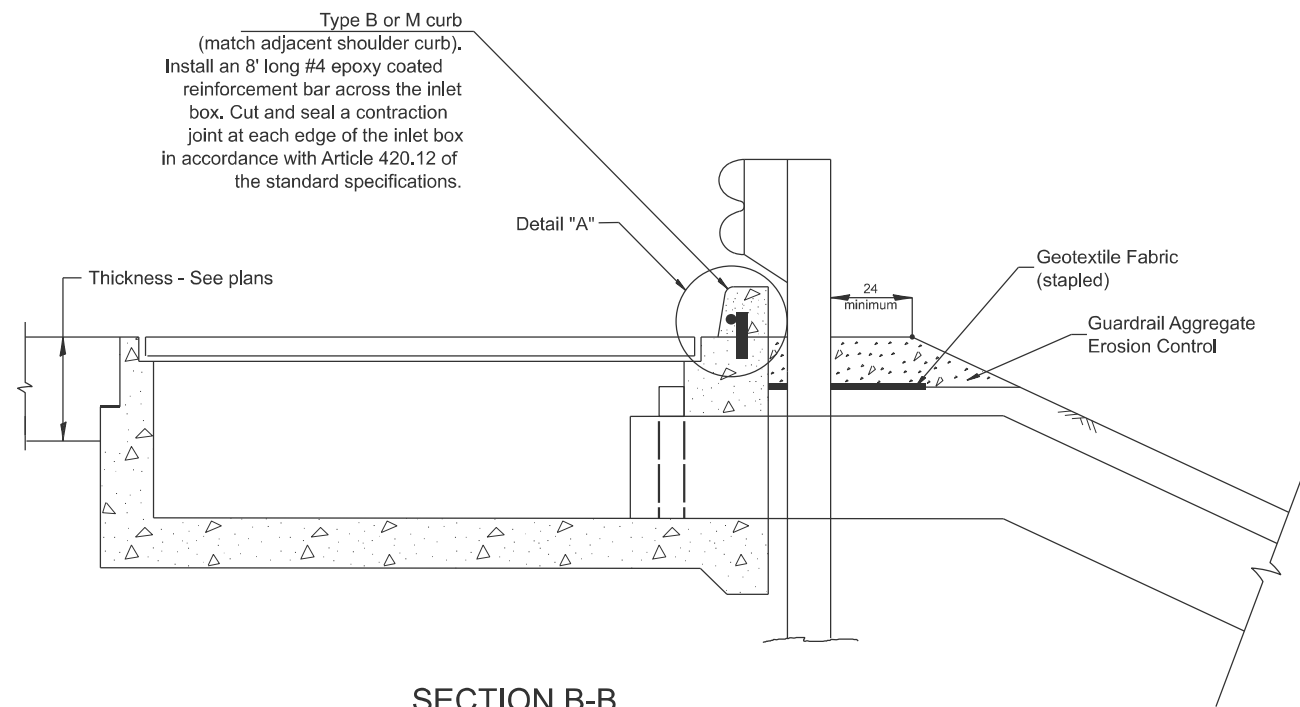

All dimensions are in inches unless otherwise noted.

MODEL: D4-630101-02  
FILE NAME: X:\Projects\Current\132-1215 IDOT D4 PTB216-036 W03 US 24\PS&E\Prefinal\PSSE Review\D4-630101.dgn

USER NAME = Cblackery	DESIGNED -	REVISED -
	DRAWN -	REVISED -
	CHECKED -	REVISED -
PLOT DATE = 1/12/2026	DATE -	REVISED -

**STATE OF ILLINOIS**  
**DEPARTMENT OF TRANSPORTATION**

**GUARDRAIL EROSION CONTROL TREATMENTS**

SCALE: NOT TO SCALE SHEET 0002 OF 2 SHEETS STA. TO STA.

F.A.P. RTE.	SECTION	COUNTY	TOTAL SHEETS	SHEET NO.
VAR. (17, 110, 111)RS-5; 18RS-6		FULTON	52	48
DISTRICT 4 DETAIL NO. 630101			CONTRACT NO. 68K17	
ILLINOIS FED. AID PROJECT				

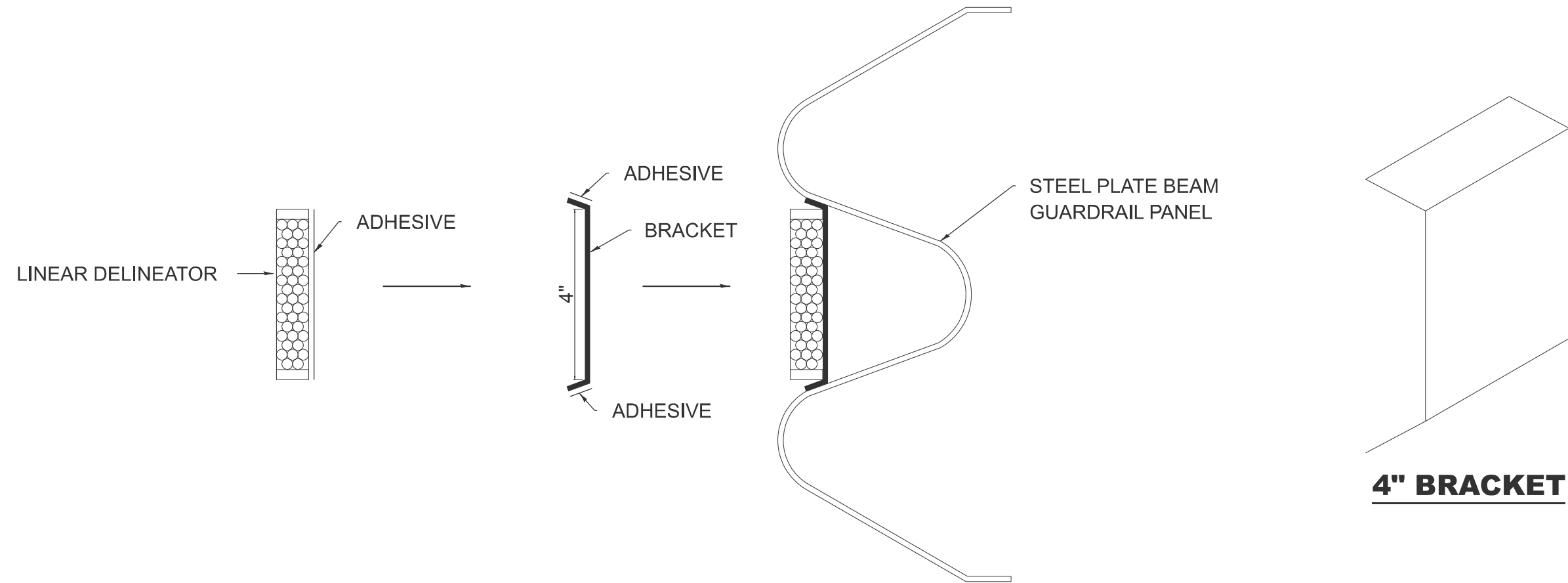

# LINEAR DELINEATOR APPLICATION TO STANDARD GALVANIZED GUARDRAIL

LINEAR DELINEATOR SHALL BE APPLIED ACCORDING TO THE MANUFACTURER'S RECOMMENDATIONS

MODEL: D4-635003  
 FILE NAME: c:\p\work\pvt\illinois.gov\thomas.cox\id1055944\D4-635003.dgn

USER NAME = thomas.cox	DESIGNED -	REVISED -
	DRAWN -	REVISED -
	CHECKED -	REVISED -
PLOT DATE = 9/23/2025	DATE -	REVISED -

**STATE OF ILLINOIS  
DEPARTMENT OF TRANSPORTATION**

SCALE: NOT TO SCALE SHEET 000 OF SHEETS STA. TO STA.

F.A.P. RTE.	SECTION	COUNTY	TOTAL SHEETS	SHEET NO.
VAR.	(17, 110, 111)RS-5; 18RS-6	FULTON	52	49
DISTRICT 4 DETAIL NO. 635003			CONTRACT NO. 68K17	
ILLINOIS FED. AID PROJECT				



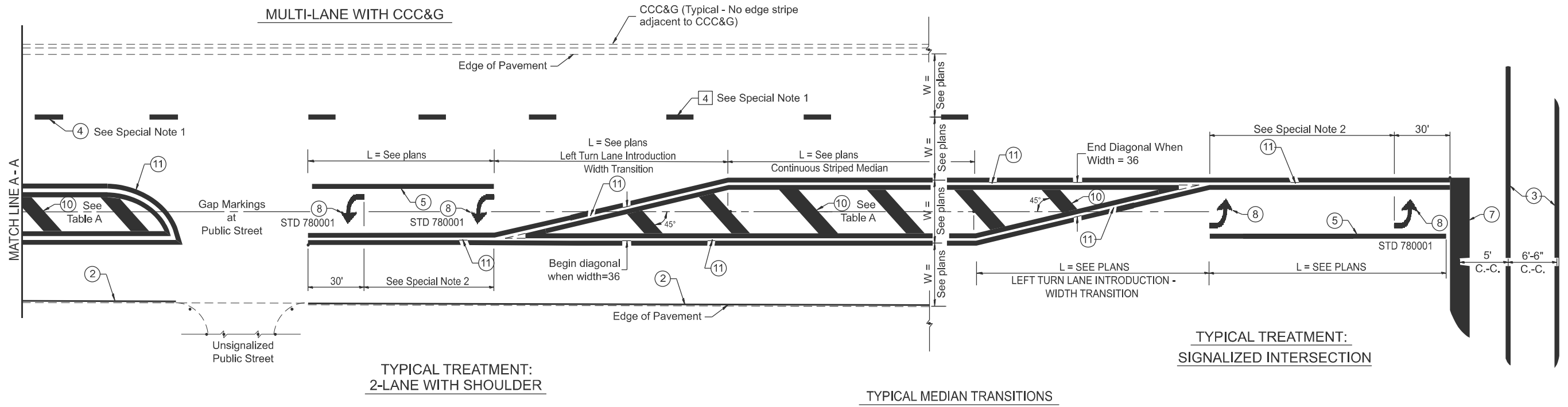

**FLUSH PAVED MEDIAN: RESTRICTED LEFT TURN LANE**

**TABLE A**  
RECOMMENDED SPACING BETWEEN DIAGONAL LINES

SPEED LIMIT RANGE	INTERSECTION CHANNELIZATION (Includes Width Transitions for Median and Left Turn Lane Introductions)	
	CONTINUOUS	
Less Than 30 mph	50'	15'
30 - 45 mph	75'	20'
Over 45 mph	150'	30'

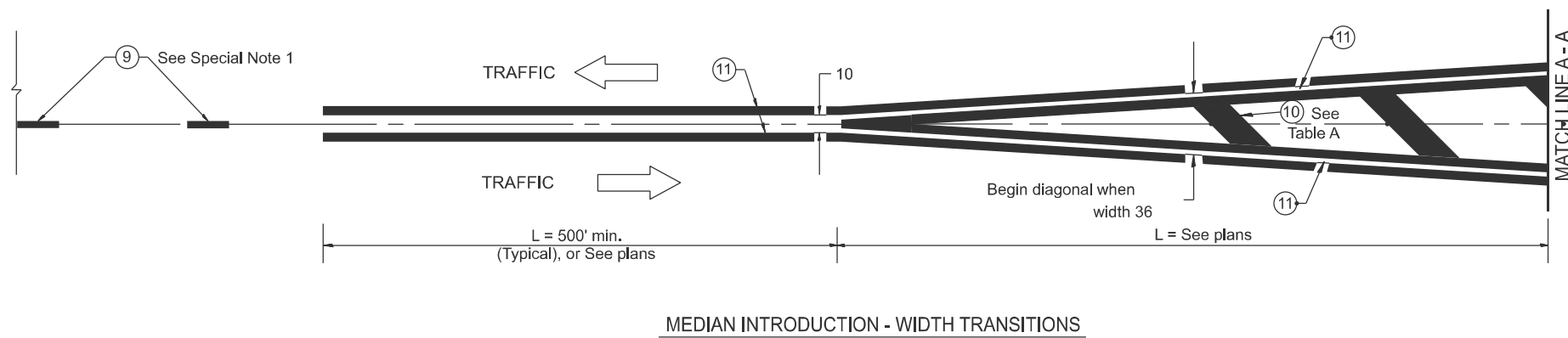

All dimensions are in inches unless otherwise noted.

MODEL: D4-780001-02  
FILE NAME: X:\Projects\Current\132-1215 IDOT D4 PTB216-036.W03 US 24\PS&E\Prefinal\PSSE Review\D4-780001.dgn

USER NAME = Cblackerby	DESIGNED -	REVISED -
	DRAWN -	REVISED -
	CHECKED -	REVISED -
PLOT DATE = 1/12/2026	DATE -	REVISED -

**STATE OF ILLINOIS**  
**DEPARTMENT OF TRANSPORTATION**

**TYPICAL PAVEMENT MARKINGS**

SCALE: NOT TO SCALE SHEET 002 OF 2 SHEETS STA. TO STA.

F.A.P. RTE.	SECTION	COUNTY	TOTAL SHEETS	SHEET NO.
VAR. (17, 110, 111)RS-5; 18RS-6		FULTON	52	51
DISTRICT 4 DETAIL NO. 780001			CONTRACT NO. 68K17	
ILLINOIS FED. AID PROJECT				

PLAN

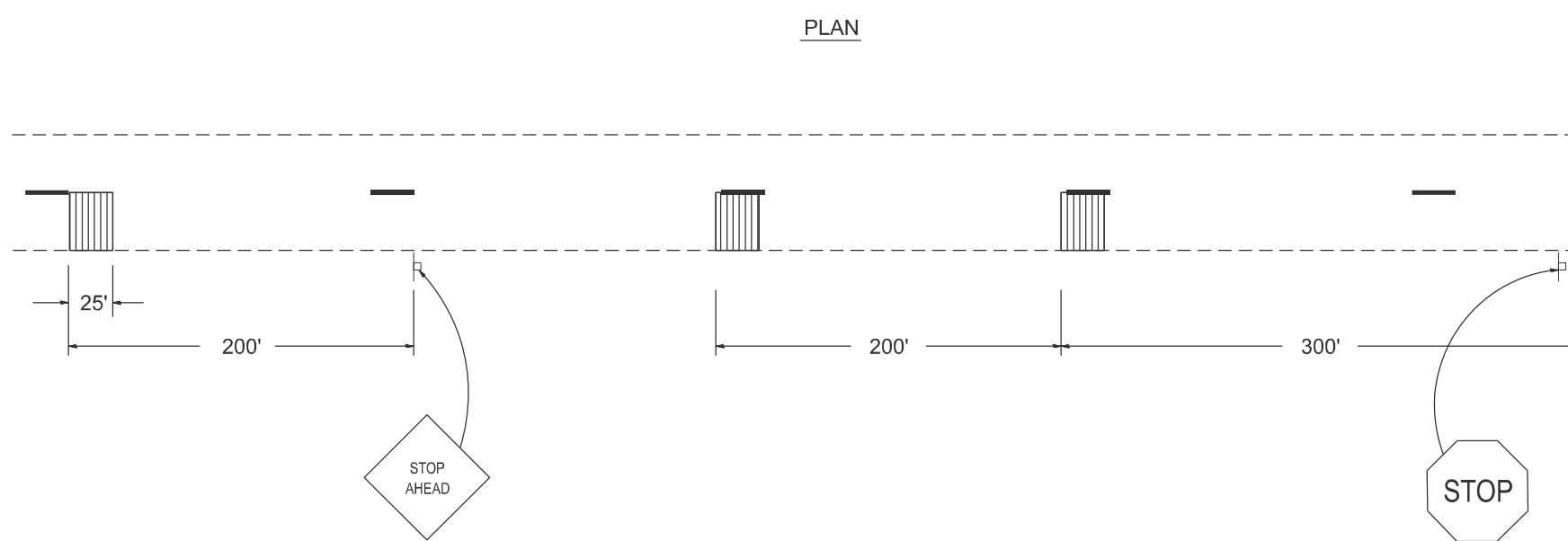

GROOVING DETAIL

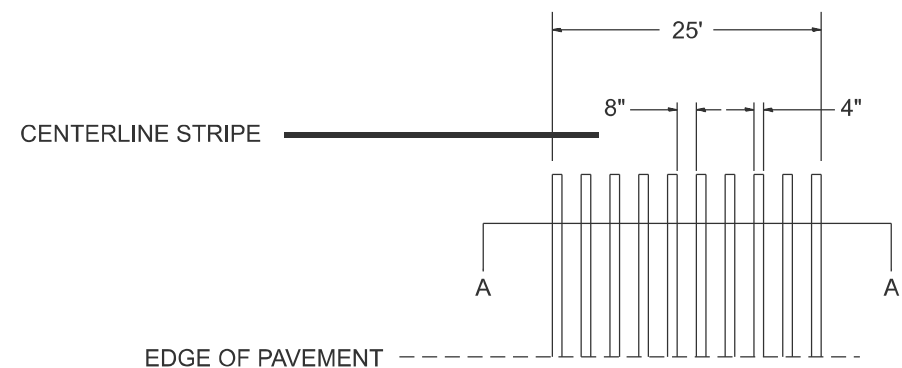

SECTION A-A

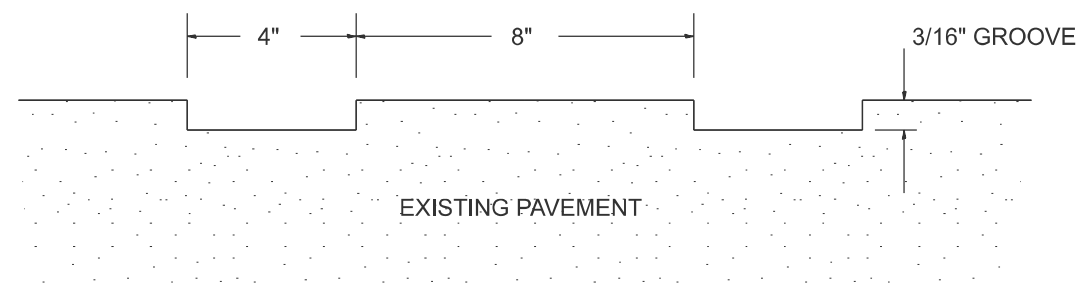

MODEL: D4-780002  
FILE NAME: c:\p\work\pav\illinois.gov\thomas.cox\td1055944\D4-780002.dgn

USER NAME = thomas.cox	DESIGNED -	REVISED -
	DRAWN -	REVISED -
	CHECKED -	REVISED -
PLOT DATE = 11/11/2024	DATE -	REVISED -

STATE OF ILLINOIS  
DEPARTMENT OF TRANSPORTATION

GROOVED-IN RUMBLE STRIP

SCALE: NOT TO SCALE SHEET 000 OF SHEETS STA. TO STA.

F.A.P. RTE.	SECTION	COUNTY	TOTAL SHEETS	SHEET NO.
VAR. (17, 110, 111)RS-5; 18RS-6		FULTON	52	52
DISTRICT 4 DETAIL NO. 780002		CONTRACT NO. 68K17		
ILLINOIS FED. AID PROJECT				