













**INDEX OF SHEETS**

- 1 COVER SHEET
- 2-3 GENERAL NOTES, INDEX OF SHEETS, HIGHWAY STANDARDS
- 4 LOCATION MAP
- 5-9 SUMMARY OF QUANTITIES
- 10-11 TRAFFIC SIGNALS - IL 159 AND LUDWIG DRIVE/SALEM PLACE
- 12-13 SOIL - IL 159 AND LUDWIG DRIVE/SALEM PLACE
- 14-15 TRAFFIC SIGNALS - IL 159 AND I-64 WB RAMP
- 16 SOIL - IL 159 AND I-64 WB RAMP
- 17-18 TRAFFIC SIGNALS - IL 159 AND I-64 EB RAMP
- 19-21 SOIL - IL 159 AND I-64 EB RAMP
- 22-23 TRAFFIC SIGNALS - IL 159 AND MARKET PLACE/ST. CLAIR SQUARE
- 24 SOIL - IL 159 AND MARKET PLACE/ST. CLAIR SQUARE
- 25-26 TRAFFIC SIGNALS - IL 159 AND FAIRVIEW HEIGHTS CENTER
- 27 SOIL - IL 159 AND FAIRVIEW HEIGHTS CENTER
- 28-30 TRAFFIC SIGNALS - IL 159 AND LINCOLN HIGHWAY/LINCOLN TRAIL
- 31-32 SOIL - IL 159 AND LINCOLN HIGHWAY/LINCOLN TRAIL
- 33-35 TRAFFIC SIGNALS - IL 159 AND LINCOLN PLACE SHOPPING CENTER
- 36-37 SOIL - IL 159 AND LINCOLN PLACE SHOPPING CENTER
- 38-40 TRAFFIC SIGNALS - IL 159 AND LONGACRE DRIVE/ASHLAND AVENUE
- 41 SOIL - IL 159 AND LONGACRE DRIVE/ASHLAND AVENUE
- 42-44 FIBER OPTIC INSTALLATION PLAN - IL 159
- 45 SYSTEM TOPO
- 46 NETWORK SCHEMATIC
- 47 PEDESTRIAN PUSH BUTTON POST DETAIL

**HIGHWAY STANDARDS**

000001-09	701301-04	720016-04
001001-02	701601-09	873001-02
001006	701602-10	877001-08
	701701-10	877002-04
701001-02	701801-06	877006-06
701006-05	701901-11	878001-11
701106-02	720001-01	880006-01
		814006-03
		862001-01

**TRAFFIC SIGNAL LEGEND**

-  PROP. TRAFFIC SIGNAL CONTROLLER
-  PROP. GROUNDING
-  PROP. NO. OF CONDUCTORS IN CABLE
-  PROP. 12" SIGNAL HEAD
-  EX. VEHICLE DETECTOR, INDUCTION LOOP
-  EX. NO. OF CONDUCTORS IN CABLE
-  EX. 12" SIGNAL HEAD
-  EX. GROUND MOUNT SERVICE
-  EX. GROUNDING
-  EX. EMERGENCY VEHICLE PREEMPTION

**GENERAL NOTES:**

1. THE CONTRACTOR SHALL VERIFY ALL DIMENSIONS AND CONDITIONS IN THE FIELD PRIOR TO CONSTRUCTION AND ORDERING MATERIALS.
2. NO SURVEY WAS PERFORMED FOR THIS PROJECT AND THE PLANS WERE CREATED USING AERIAL IMAGERY AND FIELD MEASUREMENTS.
3. ABANDONED UNDERGROUND UTILITIES THAT CONFLICT WITH CONSTRUCTION SHALL BE DISPOSED OF OUTSIDE THE LIMITS OF THE RIGHT OF WAY, ACCORDING TO THE ARTICLE 202.30 OF THE STANDARD SPECIFICATION AND AS DIRECTED BY THE ENGINEER. THIS WORK WILL NOT BE PAID FOR SEPARATELY BUT SHALL BE INCLUDED IN THE COSTS OF THE UNDERGROUND CONDUIT.
4. THE DEPARTMENT STRONGLY ENCOURAGES THE PRIME CONTRACTOR AND THEIR APPROVED SUBCONTRACTORS TO HIRE MINORITY, WOMEN AND DISADVANTAGED INDIVIDUALS FROM ITS FEDERALLY FUNDED HIGHWAY CONSTRUCTION CAREERS TRAINING PROGRAM (HCCTP) TO HELP MEET WORKFORCE AND TRAINEE GOALS. THIS PROGRAM IS TRAINING MINORITIES, WOMEN AND DISADVANTAGED INDIVIDUALS IN HIGHWAY CONSTRUCTION RELATED SKILLS, E.G. MATH FOR THE TRADES, JOB READINESS, TECHNICAL SKILLS COURSE WORK (CARPENTRY, CONCRETE FLATWORK, BLUEPRINT READING, SITE PLAN, SITE WORK, TOOLS USE, ETC.) AND OSHA 10 HOUR CERTIFICATION. TO PREPARE THEM FOR A CAREER IN THE HIGHWAY CONSTRUCTION TRADES, GRADUATES ARE WELL TRAINED AND READY TO BECOME PRODUCTIVE ENTRY-LEVEL CONSTRUCTION WORKERS. CONTACT THE DISTRICT 8 EEO OFFICE AT (618) 346-3360 AND/OR THE HCCTP COORDINATOR AT (618) 874-6528 TO LEARN MORE ABOUT THE PROGRAM AND FOR ASSISTANCE IN MEETING WORKFORCE AND TRAINEE GOALS.
5. EXISTING UTILITY LOCATIONS SHOWN ON THESE PLANS WERE COMPILED FROM THE BEST AVAILABLE RECORDS. EXACT DISTANCES AND LOCATIONS OF UTILITIES TO BE RELOCATED HAVE NOT BEEN DETERMINED. ALL UTILITIES, EITHER SHOWN OR NOT SHOWN, IN DIRECT CONFLICT WITH THE CONSTRUCTION SHALL BE RELOCATED BY OTHERS (RESPECTIVE UTILITY COMPANY). CONTRACTORS SHALL COORDINATE WITH THE VARIOUS TO ESTABLISH EXACT LOCATIONS AND DEPTHS PRIOR TO EXCAVATING. CONTRACTOR SHALL BE RESPONSIBLE FOR PROTECTING AND SUPPORTING ALL UTILITIES DURING CONSTRUCTION OPERATIONS. CONTRACTOR SHALL CONTACT THE JOINT UTILITY LOCATING INFORMATION FOR EXCAVATORS (JULIE) AT 1-800-892-0123 FOR LOCATING THE VARIOUS UTILITIES DURING CONSTRUCTION.
6. THE CONTRACTOR SHALL NOTIFY EACH AFFECTED PROPERTY OWNER A MINIMUM OF 48 HOURS PRIOR TO COMMENCEMENT OF ANY CONSTRUCTION AND/ OR GRADING.

**LOCATION 1**

**IL ROUTE 159 AT LUDWIG DRIVE/ SALEM PLACE**

AMEREN ILLINOIS  
AT&T ILLINOIS  
CHARTER SPECTRUM  
CLEARWAVE COMMUNICATIONS  
CASEYVILLE TOWNSHIP SEWER SYSTEM  
EVERSTREAM GLC HOLDING CO  
EXTENENT SYSTEMS LLC  
CITY OF FAIRVIEW HEIGHTS  
MCI/ VERIZON  
LEVEL 3/ LUMEN  
CITY OF O'FALLON  
BUCKEYE PARTNERS

GAS & ELECTRIC  
COMMUNICATIONS  
CABLE TV  
COMMUNICATIONS  
SEWER  
COMMUNICATIONS  
COMMUNICATIONS  
SEWER  
COMMUNICATIONS  
COMMUNICATIONS  
SEWER & WATER  
PIPELINE

**LOCATION 2**

**IL ROUTE 159 AT I-64 WB RAMP**

AMEREN ILLINOIS  
AT&T ILLINOIS  
CHARTER SPECTRUM  
CLEARWAVE COMMUNICATIONS  
CASEYVILLE TOWNSHIP SEWER SYSTEM  
EVERSTREAM GLC HOLDING CO  
EXTENENT SYSTEMS LLC  
CITY OF FAIRVIEW HEIGHTS  
MCI/ VERIZON  
CITY OF O'FALLON  
BUCKEYE PARTNERS

GAS & ELECTRIC  
COMMUNICATIONS  
CABLE TV  
COMMUNICATIONS  
SEWER  
COMMUNICATIONS  
COMMUNICATIONS  
SEWER  
COMMUNICATIONS  
SEWER & WATER  
PIPELINE

**LOCATION 3**

**IL ROUTE 159 AT I-64 EB RAMP**

AMEREN ILLINOIS  
AT&T ILLINOIS  
CHARTER SPECTRUM  
CLEARWAVE COMMUNICATIONS  
CASEYVILLE TOWNSHIP SEWER SYSTEM  
EVERSTREAM GLC HOLDING CO  
EXTENENT SYSTEMS LLC  
CITY OF FAIRVIEW HEIGHTS  
MCI/ VERIZON  
CITY OF O'FALLON  
BUCKEYE PARTNERS

GAS & ELECTRIC  
COMMUNICATIONS  
CABLE TV  
COMMUNICATIONS  
SEWER  
COMMUNICATIONS  
COMMUNICATIONS  
COMMUNICATIONS  
COMMUNICATIONS  
SEWER & WATER  
PIPELINE

**LOCATION 4**

**IL ROUTE 159 AT MARKET PLACE/ ST. CLAIR SQUARE**

AMEREN ILLINOIS  
AT&T ILLINOIS  
CHARTER SPECTRUM  
CLEARWAVE COMMUNICATIONS  
CASEYVILLE TOWNSHIP SEWER SYSTEM  
EVERSTREAM GLC HOLDING CO  
EXTENENT SYSTEMS LLC  
CITY OF FAIRVIEW HEIGHTS  
MCI/ VERIZON  
CITY OF O'FALLON  
BUCKEYE PARTNERS

GAS & ELECTRIC  
COMMUNICATIONS  
CABLE TV  
COMMUNICATIONS  
SEWER  
COMMUNICATIONS  
COMMUNICATIONS  
SEWER  
COMMUNICATIONS  
SEWER & WATER  
PIPELINE

**LOCATION 5**

**IL ROUTE 159 AT FAIRVIEW HEIGHTS CENTRE**

AMEREN ILLINOIS  
AT&T ILLINOIS  
CHARTER SPECTRUM  
CLEARWAVE COMMUNICATIONS  
CASEYVILLE TOWNSHIP SEWER SYSTEM  
EVERSTREAM GLC HOLDING CO  
EXTENENT SYSTEMS LLC  
FIDELITY COMMUNICATIONS SERVICES INC  
MCI/ VERIZON  
CITY OF O'FALLON  
BUCKEYE PARTNERS

GAS & ELECTRIC  
COMMUNICATIONS  
CABLE TV  
COMMUNICATIONS  
SEWER  
COMMUNICATIONS  
COMMUNICATIONS  
COMMUNICATIONS  
COMMUNICATIONS  
SEWER & WATER  
PIPELINE

**LOCATION 6**

**IL ROUTE 159 AT LINCOLN HIGHWAY/LINCOLN TRAIL**

AMEREN ILLINOIS  
AT&T ILLINOIS  
I-3 BROADBAND  
CHARTER SPECTRUM  
CLEARWAVE COMMUNICATIONS  
CASEYVILLE TOWNSHIP SEWER SYSTEM  
EVERSTREAM  
EXTENENT SYSTEMS LLC  
FIDELITY COMMUNICATIONS SERVICES INC  
CITY OF FAIRVIEW HEIGHTS  
VERIZON  
CITY OF O'FALLON  
BUCKEYE PARTNERS

GAS & ELECTRIC  
COMMUNICATIONS  
COMMUNICATIONS  
CABLE TV  
COMMUNICATIONS  
SEWER  
COMMUNICATIONS  
COMMUNICATIONS  
SEWER  
COMMUNICATIONS  
SEWER & WATER  
PIPELINE

REV - MS

MODEL: Default  
FILE NAME: C:\Sharepoint\ITERIS, INC\Systems - Midwest - Chicago Construction\DOT\_PFB\_201-041\_D8 ITS\12082 - IL 159 Signal & Interconnect\CADD\Draws File\11\_159-std-standards\_01.dwg



USER NAME = bfunk	DESIGNED - BF	REVISED -
	DRAWN - BF	REVISED -
PLOT SCALE = 2,000 ' / in.	CHECKED - AD	REVISED -
PLOT DATE = 8/5/2025	DATE - 8/5/25	REVISED -

**STATE OF ILLINOIS  
DEPARTMENT OF TRANSPORTATION**

**GENERAL NOTES, INDEX OF SHEETS  
HIGHWAY STANDARDS, TRAFFIC SIGNALS LEGEND**

SCALE: SHEET OF SHEETS STA. TO STA.

F.A.P. RTE.	SECTION	COUNTY	TOTAL SHEETS	SHEET NO.
600	(130, 130-1, 130-2)/75-3, 82-575	ST. CLAIR	47	2
CONTRACT NO. 76R78				
ILLINOIS		FED. AID PROJECT		

LOCATION 7

IL ROUTE 159 AT LINCOLN PLACE SHOPPING CENTER

AMEREN ILLINOIS  
 AT&T ILLINOIS  
 CHARTER SPECTRUM  
 CLEARWAVE COMMUNICATIONS  
 CASEYVILLE TOWNSHIP SEWER SYSTEM  
 EXTENENT SYSTEMS LLC  
 FIDELITY COMMUNICATIONS SERVICES INC  
 CITY OF FAIRVIEW HEIGHTS  
 MCI/ VERIZON  
 CITY OF O'FALLON  
 BUCKEYE PARTNERS

GAS & ELECTRIC  
 COMMUNICATIONS  
 CABLE TV  
 COMMUNICATIONS  
 SEWER  
 COMMUNICATIONS  
 COMMUNICATIONS  
 SEWER  
 COMMUNICATIONS  
 SEWER & WATER  
 PIPELINE

LOCATION 8

IL ROUTE 159 AT LONGACRE DRIVE/ ASHLAND AVENUE

AMEREN ILLINOIS  
 AT&T ILLINOIS  
 CHARTER SPECTRUM  
 CLEARWAVE COMMUNICATIONS  
 CASEYVILLE TOWNSHIP SEWER SYSTEM  
 EVERSTREAM GLC HOLDING CO  
 FIDELITY COMMUNICATIONS SERVICES INC  
 CITY OF FAIRVIEW HEIGHTS  
 MCI/ VERIZON  
 CITY OF O'FALLON

GAS & ELECTRIC  
 COMMUNICATIONS  
 CABLE TV  
 COMMUNICATIONS  
 SEWER  
 COMMUNICATIONS  
 COMMUNICATIONS  
 SEWER  
 COMMUNICATIONS  
 SEWER & WATER

MODEL: D:\default  
 FILE NAME: C:\Sharepoint\ITERIS, INC\Systems - Midwest - Chicago Construction\DOT\_PFB\_201-041\_DB ITS\12082 - IL 159 Signal & Interconnect\CAD\Draws Files\IL\_159-signal\rate\_02.dwg



USER NAME = bfunk	DESIGNED - BF	REVISED -
	DRAWN - BF	REVISED -
PLOT SCALE = 2,0000' / in.	CHECKED - AD	REVISED -
PLOT DATE = 8/5/2025	DATE - 8/5/25	REVISED -

**STATE OF ILLINOIS  
 DEPARTMENT OF TRANSPORTATION**

**GENERAL NOTES, INDEX OF SHEETS  
 HIGHWAY STANDARDS, TRAFFIC SIGNALS LEGEND**

SCALE: SHEET OF SHEETS STA. TO STA.

F.A.P. RTE.	SECTION	COUNTY	TOTAL SHEETS	SHEET NO.
600	(130, 130-1, 130-2)TS-3, 82-575	ST. CLAIR	47	3
				CONTRACT NO. 76R78
		ILLINOIS	FED. AID PROJECT	

### LOCATION MAP



### SUMMARY OF LOCATIONS

NO.	SHEET	INTERSECTION/INTERCONNECT
1	12-15	IL ROUTE 159 AND LUDWIG DRIVE/SALEM PLACE
2	16-18	IL ROUTE 159 AND I-64 N RAMP
3	19-23	IL ROUTE 159 AND I-64 S RAMP
4	24-26	IL ROUTE 159 AND MARKET PLACE/ST CLAIR SQUARE
5	27-29	IL ROUTE 159 AND FAIRVIEW HEIGHTS CENTRE
6	30-34	IL ROUTE 159 AND LINCOLN HIGHWAY
7	35-39	IL ROUTE 159 AND LINCOLN PLACE SC
8	40-44	IL ROUTE 159 AND LONGACRE DRIVE/ASHLAND AVENUE

MODEL: Default  
 FILE NAME: C:\Sharepoint\ITERIS, INC\Systems - Midwest - Chicago Construction\DOT\_PFB\_201-041\_DB ITS\12082 - IL 159 Signal & Interconnect\CADD\Sheet Files\0812082\_IL\_Route 159\_Location.dgn



USER NAME = bfunk	DESIGNED - BF	REVISED -
	DRAWN - BF	REVISED -
PLOT SCALE = 100,0000' / in.	CHECKED - AD	REVISED -
PLOT DATE = 8/5/2025	DATE - 7/14/24	REVISED -

**STATE OF ILLINOIS  
DEPARTMENT OF TRANSPORTATION**

**LOCATION MAP**

SCALE: SHEET OF SHEETS STA. TO STA.

F.A.P. RTE.	SECTION	COUNTY	TOTAL SHEETS	SHEET NO.
600	(130, 130-1, 130-2)TS-3, 82-575	ST. CLAIR	47	4
CONTRACT NO. 76R78				
ILLINOIS FED. AID PROJECT				

CODE NUMBER	ITEM DESCRIPTION	UNIT	80% FED 20% STATE TOTAL QUANTITY	CONSTRUCTION CODE	
				FAP 600	FAP 600
				TRAFFIC SIGNALS 0021 URBAN CMAQ	TRAFFIC SIGNALS 0021 URBAN HSIP
* 66900200	NON-SPECIAL WASTE DISPOSAL	CU YD	22		22
* 66900210	HAZARDOUS WASTE DISPOSAL	CU YD	32		32
* 66900530	SOIL DISPOSAL ANALYSIS	EACH	8		8
* 66901001	REGULATED SUBSTANCES PRE-CONSTRUCTION PLAN	L SUM	1		1
* 66901003	REGULATED SUBSTANCES FINAL CONSTRUCTION REPORT	L SUM	1		1
* 66901006	REGULATED SUBSTANCES MONITORING	CAL DA	20		20
67000400	ENGINEER'S FIELD OFFICE, TYPE A	CAL MO	12	2	10
67100100	MOBILIZATION	L SUM	1	0.2	0.8
70102630	TRAFFIC CONTROL AND PROTECTION, STANDARD 701601	L SUM	1	0.1	0.9
70102632	TRAFFIC CONTROL AND PROTECTION, STANDARD 701602	L SUM	1	0.1	0.9
70102635	TRAFFIC CONTROL AND PROTECTION, STANDARD 701701	L SUM	1	0.1	0.9
70102640	TRAFFIC CONTROL AND PROTECTION, STANDARD 701801	L SUM	1	0.1	0.9
70200100	NIGHTTIME WORK ZONE LIGHTING	L SUM	1		1
* 72000100	SIGN PANEL - TYPE 1	SQ FT	120		120
* 72400710	RELOCATE SIGN PANEL - TYPE 1	SQ FT	133		133
80300100	LOCATING UNDERGROUND CABLE	FOOT	80		80

\* SPECIALTY ITEM

REV - MS

MODEL Path: C:\Sharepoint\ITERIS, INC\Systems - Midwest - Chicago Construction\DOT\_PFB\_201-041\_DB ITS\12082 - IL 159-Signal & Interconnect\CAD\Drawings File\11\_159-srch-01\_500\_ITERIS.dgn



USER NAME = bfunk
PLOT SCALE = 100,0000 ' / in.
PLOT DATE = 8/5/2025

DESIGNED - BF	REVISOR -
DRAWN - BF	REVISION -
CHECKED - AD	REVISION -
DATE - 8/5/25	REVISION -

**STATE OF ILLINOIS  
DEPARTMENT OF TRANSPORTATION**

**SUMMARY OF QUANTITIES**

SCALE:	SHEET	OF	SHEETS	STA.	TO STA.
--------	-------	----	--------	------	---------

F.A.P. RTE.	SECTION	COUNTY	TOTAL SHEETS	SHEET NO.
600	(130, 130-1, 130-2)TS-3	ST. CLAIR	47	5
			CONTRACT NO. 76R78	
		ILLINOIS	FED. AID PROJECT	

CODE NUMBER	ITEM DESCRIPTION	UNIT	80% FED 20% STATE TOTAL QUANTITY	CONSTRUCTION CODE	
				FAP 600	FAP 600
				TRAFFIC SIGNALS 0021 URBAN CMAQ	TRAFFIC SIGNALS 0021 URBAN HSIP
81028350	UNDERGROUND CONDUIT, PVC, 2" DIA.	FOOT	209		209
81028370	UNDERGROUND CONDUIT, PVC, 3" DIA.	FOOT	497		497
81028390	UNDERGROUND CONDUIT, PVC, 4" DIA.	FOOT	1097		1097
81028740	UNDERGROUND CONDUIT, COILABLE NONMETALLIC CONDUIT, 1 1/2" DIA.	FOOT	2533	2533	
85000200	MAINTENANCE OF EXISTING TRAFFIC SIGNAL INSTALLATION	EACH	8		8
85700200	FULL-ACTUATED CONTROLLER AND TYPE IV CABINET	EACH	7	7	
85700300	FULL-ACTUATED CONTROLLER AND TYPE V CABINET	EACH	1	1	
86200300	UNINTERRUPTABLE POWER SUPPLY, EXTENDED	EACH	5		5
87301215	ELECTRIC CABLE IN CONDUIT, SIGNAL NO. 14 2C	FOOT	2175		2175
87301225	ELECTRIC CABLE IN CONDUIT, SIGNAL NO. 14 3C	FOOT	6097		6097
87301245	ELECTRIC CABLE IN CONDUIT, SIGNAL NO. 14 5C	FOOT	21759		21759
87301255	ELECTRIC CABLE IN CONDUIT, SIGNAL NO. 14 7C	FOOT	8008		8008
87301900	ELECTRIC CABLE IN CONDUIT, EQUIPMENT GROUNDING CONDUCTOR, NO. 6 1C	FOOT	1381		1381
87700170	STEEL MAST ARM ASSEMBLY AND POLE, 26 FT.	EACH	1		1
87700210	STEEL MAST ARM ASSEMBLY AND POLE, 34 FT.	EACH	1		1
87700230	STEEL MAST ARM ASSEMBLY AND POLE, 38 FT.	EACH	1		1

REV - MS

MODEL: Default  
 FILE NAME: C:\Sharepoint\ITERIS, INC\Systems - Midwest - Chicago Construction\DOT\_PFB\_201-041\_DB ITS\12082 - IL 159-Signal & Interconnect\CAD\Draws File\11\_159-sht-01\_500\_ITERIS.dgn



USER NAME = bfunk
PLOT SCALE = 100,0000 ' / in.
PLOT DATE = 8/5/2025

DESIGNED - BF	REVISOR -
DRAWN - BF	REVISIONS -
CHECKED - AD	REVISIONS -
DATE - 8/5/25	REVISIONS -

**STATE OF ILLINOIS  
DEPARTMENT OF TRANSPORTATION**

**SUMMARY OF QUANTITIES**

SCALE: SHEET OF SHEETS STA. TO STA.

F.A.P. RTE.	SECTION	COUNTY	TOTAL SHEETS	SHEET NO.
600	(130, 130-1, 130-2)TS-3, 82-575	ST. CLAIR	47	6
CONTRACT NO. 76R78				
ILLINOIS FED. AID PROJECT				

CODE NUMBER	ITEM DESCRIPTION	UNIT	TOTAL QUANTITY	CONSTRUCTION CODE	
				FAP 600	FAP 600
				TRAFFIC SIGNALS	TRAFFIC SIGNALS
				0021 URBAN CMAQ	0021 URBAN HSIP
87700240	STEEL MAST ARM ASSEMBLY AND POLE, 40 FT.	EACH	1		1
87700250	STEEL MAST ARM ASSEMBLY AND POLE, 42 FT.	EACH	3		3
87700260	STEEL MAST ARM ASSEMBLY AND POLE, 44 FT.	EACH	1		1
87700270	STEEL MAST ARM ASSEMBLY AND POLE, 46 FT.	EACH	9		9
87700280	STEEL MAST ARM ASSEMBLY AND POLE, 48 FT.	EACH	1		1
87700300	STEEL MAST ARM ASSEMBLY AND POLE, 52 FT.	EACH	1		1
87700310	STEEL MAST ARM ASSEMBLY AND POLE, 54 FT.	EACH	2		2
87700330	STEEL MAST ARM ASSEMBLY AND POLE, 56 FT.	EACH	1		1
87700340	STEEL MAST ARM ASSEMBLY AND POLE, 58 FT.	EACH	1		1
87700400	STEEL MAST ARM ASSEMBLY AND POLE, 60 FT.	EACH	1		1
87700404	STEEL MAST ARM ASSEMBLY AND POLE, 62 FT.	EACH	1		1
87700418	STEEL MAST ARM ASSEMBLY AND POLE, 68 FT.	EACH	2		2
87700420	STEEL MAST ARM ASSEMBLY AND POLE, 70 FT.	EACH	1		1
87700428	STEEL MAST ARM ASSEMBLY AND POLE, 74 FT.	EACH	1		1
87800400	CONCRETE FOUNDATION, TYPE E 30-INCH DIAMETER	FOOT	38		38
87800415	CONCRETE FOUNDATION, TYPE E 36-INCH DIAMETER	FOOT	255		255

REV - MS

MODEL Path: C:\Sharepoint\ITERIS - Midwest - Chicago Construction\DOT - ILL 159-Signal & Interconnect\CAD\Draws - File\Ill\_159-sig-co\_500\_ITERIS.dgn



USER NAME = bfunk
PLOT SCALE = 100,0000 ' / in.
PLOT DATE = 8/5/2025

DESIGNED - BF	REVISIED -
DRAWN - BF	REVISIED -
CHECKED - AD	REVISIED -
DATE - 8/5/25	REVISIED -

**STATE OF ILLINOIS  
DEPARTMENT OF TRANSPORTATION**

**SUMMARY OF QUANTITIES**

SCALE: SHEET OF SHEETS STA. TO STA.

F.A.P. RTE.	SECTION	COUNTY	TOTAL SHEETS	SHEET NO.
600	(130, 130-1, 130-2)TS-3, 82-575	ST. CLAIR	47	7
CONTRACT NO. 76R78				
ILLINOIS FED. AID PROJECT				

CODE NUMBER	ITEM DESCRIPTION	UNIT	TOTAL QUANTITY	CONSTRUCTION CODE	
				FAP 600	FAP 600
				TRAFFIC SIGNALS	TRAFFIC SIGNALS
				0021 URBAN CMAQ	0021 URBAN HSIP
87800420	CONCRETE FOUNDATION, TYPE E 42-INCH DIAMETER	FOOT	164		164
87900100	DRILL EXISTING FOUNDATION	EACH	2	2	
87900200	DRILL EXISTING HANDHOLE	EACH	68		68
88030020	SIGNAL HEAD, LED, 1-FACE, 3-SECTION, MAST-ARM MOUNTED	EACH	68		68
88030050	SIGNAL HEAD, LED, 1-FACE, 3-SECTION, BRACKET MOUNTED	EACH	36		36
88030070	SIGNAL HEAD, LED, 1-FACE, 4-SECTION, BRACKET MOUNTED	EACH	14		14
88030080	SIGNAL HEAD, LED, 1-FACE, 4-SECTION, MAST ARM MOUNTED	EACH	17		17
88030100	SIGNAL HEAD, LED, 1-FACE, 5-SECTION, BRACKET MOUNTED	EACH	2		2
88030110	SIGNAL HEAD, LED, 1-FACE, 5-SECTION, MAST-ARM MOUNTED	EACH	2		2
88102717	PEDESTRIAN SIGNAL HEAD, LED, 1-FACE, BRACKET MOUNTED WITH COUNTDOWN TIMER	EACH	2		2
88102747	PEDESTRIAN SIGNAL HEAD, LED, 2-FACE, BRACKET MOUNTED WITH COUNTDOWN TIMER	EACH	6		6
88200510	TRAFFIC SIGNAL BACKPLATE, RETROREFLECTIVE	EACH	86		86
89501250	RELOCATE EXISTING TRAFFIC SIGNAL EQUIPMENT	EACH	8		8
89502300	REMOVE ELECTRIC CABLE FROM CONDUIT	FOOT	4000		4000
89502375	REMOVE EXISTING TRAFFIC SIGNAL EQUIPMENT	EACH	8		8
89502385	REMOVE EXISTING CONCRETE FOUNDATION	EACH	34		34

REV - MS

MODEL: Default  
 FILE NAME: C:\Sharepoint\ITERIS - INC\Systems - Midwest - Chicago Construction\DOT - PFB - 201-041 DB ITS\12082 - IL 159-Signal & Interconnect\CAD\Drawings - Files\159-sig-c01\_500\_ITERIS.dgn



USER NAME = bfunk
PLOT SCALE = 100,0000 ' / in.
PLOT DATE = 8/5/2025

DESIGNED - BF	REVISIED -
DRAWN - BF	REVISIED -
CHECKED - AD	REVISIED -
DATE - 8/5/25	REVISIED -

**STATE OF ILLINOIS  
DEPARTMENT OF TRANSPORTATION**

**SUMMARY OF QUANTITIES**

SCALE: SHEET OF SHEETS STA. TO STA.

F.A.P. RTE.	SECTION	COUNTY	TOTAL SHEETS	SHEET NO.
600	(130, 130-1, 130-2)TS-3, 82-575	ST. CLAIR	47	8
			CONTRACT NO. 76R78	
		ILLINOIS FED. AID PROJECT		

CODE NUMBER	ITEM DESCRIPTION	UNIT	TOTAL QUANTITY	CONSTRUCTION CODE	
				FAP 600	FAP 600
				TRAFFIC SIGNALS	TRAFFIC SIGNALS
				0021 URBAN CMAQ	0021 URBAN HSIP
X0324085	EMERGENCY VEHICLE PRIORITY SYSTEM LINE SENSOR CABLE, NO. 20 3/C	FOOT	4904		4904
X8891007	VIDEO VEHICLE DETECTION SYSTEM COMPLETE	EACH	2		2
X8710010	FIBER LAYOUT	L SUM	1	1	
X1400500	COMMUNICATIONS VAULT, 24"X36"	EACH	3	3	
X8710036	FIBER OPTIC CABLE 12 FIBERS, SINGLE MODE	FOOT	540	540	
X8710039	FIBER OPTIC CABLE 144 FIBERS, SINGLE MODE	FOOT	7155	7155	
X8710101	ETHERNET MANAGE SWITCH	EACH	1	1	
X8710103	ETHERNET SWITCH	EACH	7	7	
X8710304	FIBER OPTIC CABLE SPLICE - LATERAL	EACH	7	7	
X8760200	ACCESSIBLE PEDESTRIAN SIGNALS	EACH	18		18
X8760201	PEDESTRIAN PUSH-BUTTON POST	EACH	16		16
X8780012	CONCRETE FOUNDATION, TYPE A 12-INCH DIAMETER	FOOT	68		68
XP000212	CLOSED CIRCUIT TELEVISION DOME CAMERA, HD	EACH	2	2	
Ø Z0076600	TRAINEES	HOUR	1500	1500	
Ø Z0076604	TRAINEES TRAINING PROGRAM GRADUATE	HOUR	1500	1500	

Ø 0042

REV - MS

MODEL: Default  
 FILE NAME: C:\Sharepoint\ITERIS - INC\Systems - Midwest - Chicago Construction\DOT\_PFB\_201-041\_DB ITS\12082 - IL 139-Signal & Interconnect\CAD\Drawings - Files\IL\_139-SH-C01\_500\_ITERIS.dgn



USER NAME = bfunk	DESIGNED - BF	REVISED -
PLOT SCALE = 100,0000 ' / in.	DRAWN - BF	REVISED -
PLOT DATE = 8/11/2025	CHECKED - AD	REVISED -
	DATE - 8/5/25	REVISED -

**STATE OF ILLINOIS  
DEPARTMENT OF TRANSPORTATION**

**SUMMARY OF QUANTITIES**

SCALE: SHEET OF SHEETS STA. TO STA.

F.A.P. RTE.	SECTION	COUNTY	TOTAL SHEETS	SHEET NO.
600	(130, 130-1, 130-2)TS-3, 82-575	ST. CLAIR	47	9
			CONTRACT NO. 76R78	
		ILLINOIS FED. AID PROJECT		

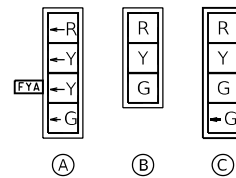

### TRAFFIC SIGNAL LEGEND

- PROPOSED CONTROLLER CABINET
- CCTV CAMERA
- PROPOSED CONDUIT

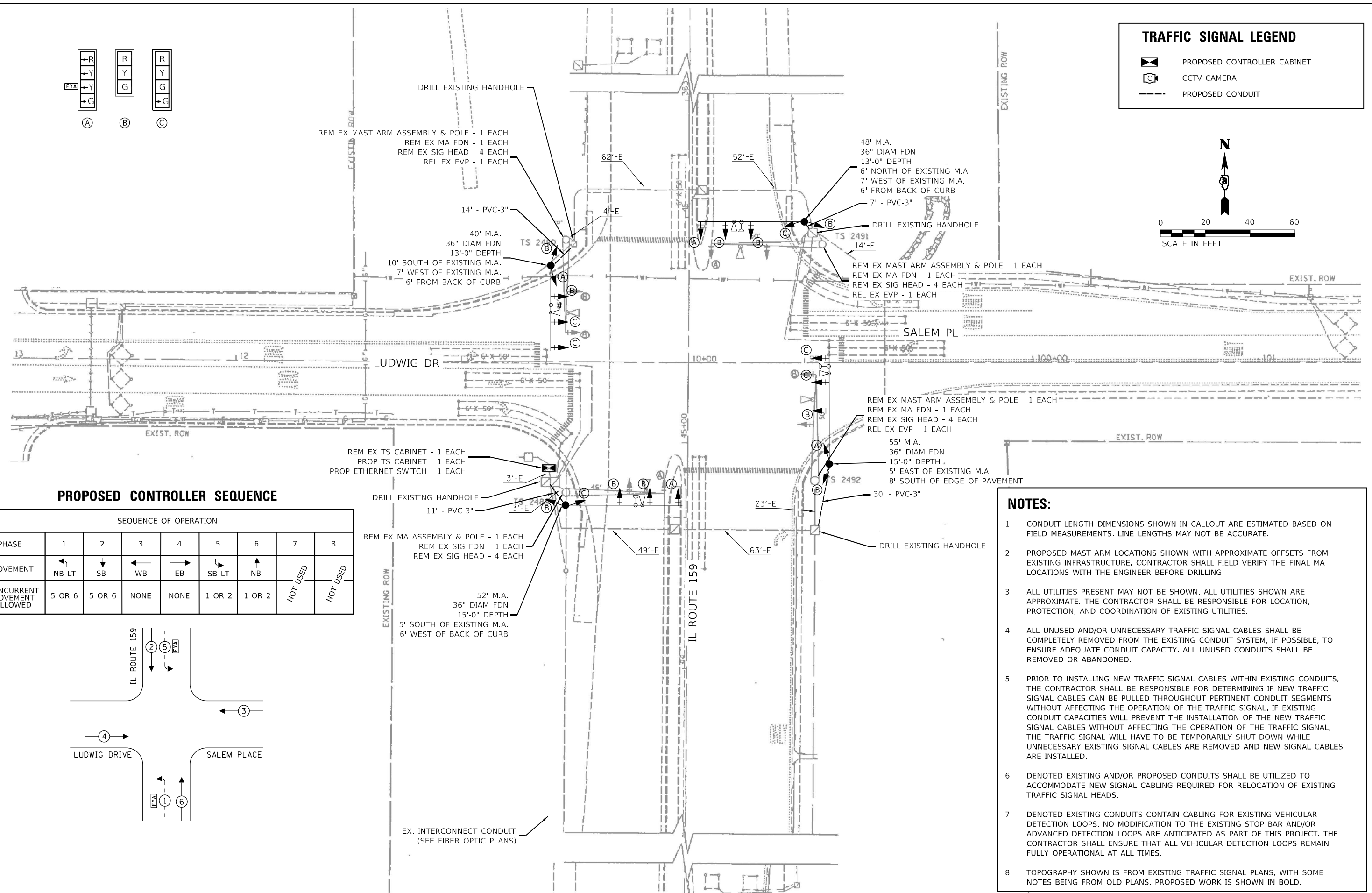
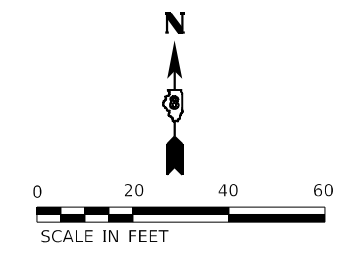

### PROPOSED CONTROLLER SEQUENCE

SEQUENCE OF OPERATION								
PHASE	1	2	3	4	5	6	7	8
MOVEMENT	NB LT	SB	WB	EB	SB LT	NB	NOT USED	NOT USED
CONCURRENT MOVEMENT ALLOWED	5 OR 6	5 OR 6	NONE	NONE	1 OR 2	1 OR 2	NOT USED	NOT USED

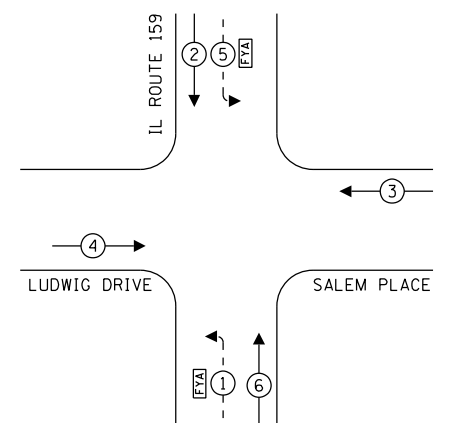

- ### NOTES:
- CONDUIT LENGTH DIMENSIONS SHOWN IN CALLOUT ARE ESTIMATED BASED ON FIELD MEASUREMENTS. LINE LENGTHS MAY NOT BE ACCURATE.
  - PROPOSED MAST ARM LOCATIONS SHOWN WITH APPROXIMATE OFFSETS FROM EXISTING INFRASTRUCTURE. CONTRACTOR SHALL FIELD VERIFY THE FINAL MA LOCATIONS WITH THE ENGINEER BEFORE DRILLING.
  - ALL UTILITIES PRESENT MAY NOT BE SHOWN. ALL UTILITIES SHOWN ARE APPROXIMATE. THE CONTRACTOR SHALL BE RESPONSIBLE FOR LOCATION, PROTECTION, AND COORDINATION OF EXISTING UTILITIES.
  - ALL UNUSED AND/OR UNNECESSARY TRAFFIC SIGNAL CABLES SHALL BE COMPLETELY REMOVED FROM THE EXISTING CONDUIT SYSTEM, IF POSSIBLE, TO ENSURE ADEQUATE CONDUIT CAPACITY. ALL UNUSED CONDUITS SHALL BE REMOVED OR ABANDONED.
  - PRIOR TO INSTALLING NEW TRAFFIC SIGNAL CABLES WITHIN EXISTING CONDUITS, THE CONTRACTOR SHALL BE RESPONSIBLE FOR DETERMINING IF NEW TRAFFIC SIGNAL CABLES CAN BE PULLED THROUGHOUT PERTINENT CONDUIT SEGMENTS WITHOUT AFFECTING THE OPERATION OF THE TRAFFIC SIGNAL, IF EXISTING CONDUIT CAPACITIES WILL PREVENT THE INSTALLATION OF THE NEW TRAFFIC SIGNAL CABLES WITHOUT AFFECTING THE OPERATION OF THE TRAFFIC SIGNAL, THE TRAFFIC SIGNAL WILL HAVE TO BE TEMPORARILY SHUT DOWN WHILE UNNECESSARY EXISTING SIGNAL CABLES ARE REMOVED AND NEW SIGNAL CABLES ARE INSTALLED.
  - DENOTED EXISTING AND/OR PROPOSED CONDUITS SHALL BE UTILIZED TO ACCOMMODATE NEW SIGNAL CABLING REQUIRED FOR RELOCATION OF EXISTING TRAFFIC SIGNAL HEADS.
  - DENOTED EXISTING CONDUITS CONTAIN CABLING FOR EXISTING VEHICULAR DETECTION LOOPS. NO MODIFICATION TO THE EXISTING STOP BAR AND/OR ADVANCED DETECTION LOOPS ARE ANTICIPATED AS PART OF THIS PROJECT. THE CONTRACTOR SHALL ENSURE THAT ALL VEHICULAR DETECTION LOOPS REMAIN FULLY OPERATIONAL AT ALL TIMES.
  - TOPOGRAPHY SHOWN IS FROM EXISTING TRAFFIC SIGNAL PLANS, WITH SOME NOTES BEING FROM OLD PLANS. PROPOSED WORK IS SHOWN IN BOLD.

MODEL: Default  
 FILE NAME: C:\Sharepoint\ITERIS, INC\Systems - Midwest - Chicago Construction\DOT\_PFB\_201-041\_DB ITS\12082 - IL 159 Signal & Interconnect\CADD\Sheet Files\0812082\_ILRoute159\_TS\_SHT\_01-Ludwig.dgn  
 MODEL: Default  
 FILE NAME: C:\Sharepoint\ITERIS, INC\Systems - Midwest - Chicago Construction\DOT\_PFB\_201-041\_DB ITS\12082 - IL 159 Signal & Interconnect\CADD\Sheet Files\0812082\_ILRoute159\_TS\_SHT\_01-Ludwig.dgn



USER NAME = bfunk	DESIGNED - AD	REVISED -
PLOT SCALE = 100,0000' / in.	DRAWN - AD	REVISED -
PLOT DATE = 2/27/2024	CHECKED - BF	REVISED -
	DATE - 2/26/24	REVISED -

STATE OF ILLINOIS  
DEPARTMENT OF TRANSPORTATION

TRAFFIC SIGNAL MODIFICATION PLAN  
IL ROUTE 159 AND LUDWIG DRIVE / SALEM PLACE

SCALE: SHEET OF SHEETS STA. TO STA.

F.A.P. RTE.	SECTION	COUNTY	TOTAL SHEETS	SHEET NO.
600	(130, 130-1, 130-2)TS-3, 82-575	ST. CLAIR	47	10
CONTRACT NO. 76R78				
ILLINOIS FED. AID PROJECT				

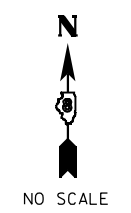

TRAFFIC SIGNAL LEGEND	
	PROP. TRAFFIC SIGNAL CONTROLLER
	PROP. CCTV CAMERA
	PROP. GROUNDING
	PROP. NO. OF CONDUCTORS IN CABLE
	PROP. CCTV CABLE
	PROP. 12" SIGNAL HEAD
	EX. VEHICLE DETECTOR, INDUCTION LOOP
	EX. NO. OF CONDUCTORS IN CABLE
	EX. 12" SIGNAL HEAD
	EX. GROUND MOUNT SERVICE
	EX. GROUNDING
	EX. EMERGENCY VEHICLE PREEMPTION
	EX. CONFIRMATION BEACON

**SCHEDULE OF QUANTITIES**

ITEM DESCRIPTION	UNIT	QTY.
SIGN PANEL - TYPE 1	SQ FT	30
RELOCATE SIGN PANEL - TYPE 1	SQ FT	32
LOCATING UNDERGROUND CABLE	FOOT	10
UNDERGROUND CONDUIT, PVC, 3" DIA.	FOOT	62
MAINTENANCE OF EXISTING TRAFFIC SIGNAL INSTALLATION	EACH	1
FULL-ACTUATED CONTROLLER AND TYPE IV CABINET	EACH	1
ELECTRIC CABLE IN CONDUIT, SIGNAL NO. 14 3C	FOOT	1182
ELECTRIC CABLE IN CONDUIT, SIGNAL NO. 14 5C	FOOT	2635
ELECTRIC CABLE IN CONDUIT, SIGNAL NO. 14 7C	FOOT	3004
ELECTRIC CABLE IN CONDUIT, EQUIPMENT GROUNDING CONDUCTOR, NO. 6 1C	FOOT	105
STEEL MAST ARM ASSEMBLY AND POLE, 40 FT.	EACH	1
STEEL MAST ARM ASSEMBLY AND POLE, 48 FT.	EACH	1
STEEL MAST ARM ASSEMBLY AND POLE, 52 FT.	EACH	1
STEEL MAST ARM ASSEMBLY AND POLE, 58 FT.	EACH	1
CONCRETE FOUNDATION, TYPE E 36-INCH DIAMETER	FOOT	56
DRILL EXISTING HANDHOLE	EACH	4
SIGNAL HEAD, LED, 1-FACE, 3-SECTION, MAST-ARM MOUNTED	EACH	6
SIGNAL HEAD, LED, 1-FACE, 3-SECTION, BRACKET MOUNTED	EACH	4
SIGNAL HEAD, LED, 1-FACE, 4-SECTION, BRACKET MOUNTED	EACH	4
SIGNAL HEAD, LED, 1-FACE, 4-SECTION, MAST ARM MOUNTED	EACH	6
TRAFFIC SIGNAL BACKPLATE, RETROREFLECTIVE	EACH	12
RELOCATE EXISTING TRAFFIC SIGNAL EQUIPMENT	EACH	1
* REMOVE ELECTRIC CABLE FROM CONDUIT	FOOT	500
REMOVE EXISTING TRAFFIC SIGNAL EQUIPMENT	EACH	1
REMOVE EXISTING CONCRETE FOUNDATION	EACH	4
EMERGENCY VEHICLE PRIORITY SYSTEM LINE SENSOR CABLE, NO. 20 3/C	FOOT	1182
ETHERNET SWITCH	EACH	1

\* NOMINAL QUANTITY TO BE USED AS NEEDED AND AS APPROVED BY ENGINEER

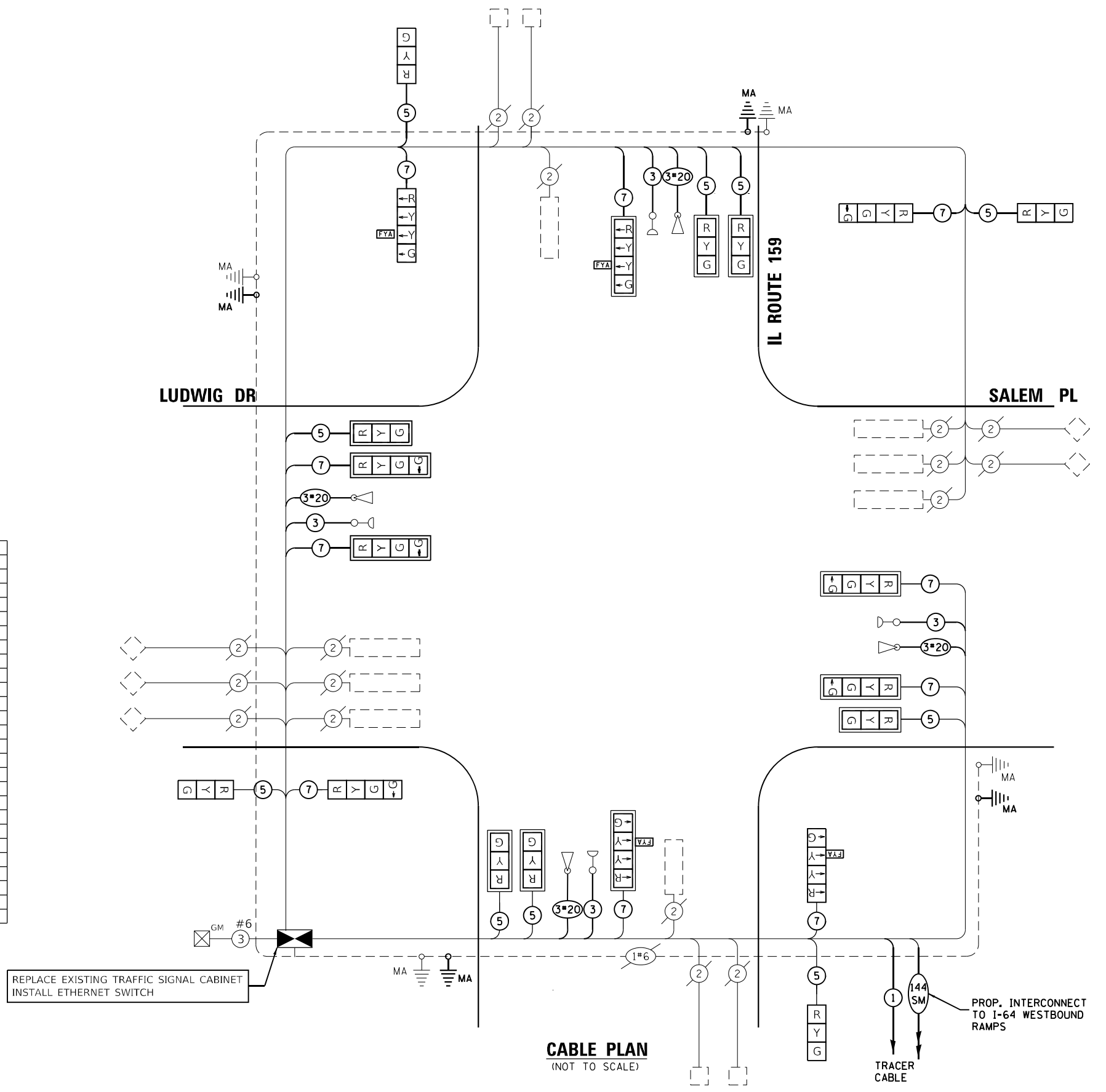

**CABLE PLAN**  
(NOT TO SCALE)

MODEL: Default  
 FILE NAME: C:\Sharepoint\ITERIS - Midwest - Chicago Construction\BIDD\TBE\_201-041\_DB ITS\12082 - IL 159 Signal & Interconnect\CADD\Sheet Files\DS12082\_IL-Route 159\_Cable\_Sht\_01-Ludwig.dgn



USER NAME = bfunck	DESIGNED - AD	REVISED -
	DRAWN - AD	REVISED -
PLOT SCALE = 100,0000' / in.	CHECKED - BF	REVISED -
PLOT DATE = 2/27/2024	DATE - 2/26/24	REVISED -

**STATE OF ILLINOIS**  
**DEPARTMENT OF TRANSPORTATION**

**TRAFFIC SIGNAL CABLE PLAN**  
**IL ROUTE 159 AND LUDWIG DRIVE / SALEM PLACE**

F.A.P. RTE.	SECTION	COUNTY	TOTAL SHEETS	SHEET NO.
600	(130, 130-1, 130-2/75-3, 82-575)	ST. CLAIR	47	11
CONTRACT NO. 76R78				
ILLINOIS FED. AID PROJECT				

SCALE: SHEET OF SHEETS STA. TO STA.





# SOIL BORING LOG

Page 1 of 1  
Date 5/29/84

ROUTE FAP 600 DESCRIPTION Traffic Signals at IL 159 and Ludwig Dr / Salem Pl LOGGED BY J. King  
SECTION 130TS LOCATION SE 1/4, SEC. 21, TWP. 2N, RNG. 8W, 3 PM  
COUNTY St. Clair DRILLING METHOD Hollow Stem Auger HAMMER TYPE 140# Automatic

STRUCT. NO. Station	D E P T H (ft)	B L O W S (/6")	U C S Qu (tsf)	M O I S T (%)	Surface Water Elev. _____ ft	Stream Bed Elev. _____ ft	Groundwater Elev.: First Encounter _____ ft	Upon Completion _____ ft	After _____ Hrs. _____ ft	D E P T H (ft)	B L O W S (/6")	U C S Qu (tsf)	M O I S T (%)
											10	2.0	26
												S	
		25	3.1	16							8	1.6	27
												B	
		25	2.7	17					562.0		6	1.3	27
												B	
		32	3.2	16									
												S	
		35	3.9	19									
												S	
		23	3.7	24									
												S	
		11	2.6	23									
												S	
		8	0.8	27									
												S	

The Unconfined Compressive Strength (UCS) Failure Mode is indicated by (B-Bulge, S-Shear, P-Penetrometer)  
The SPT (N value) is the sum of the last two blow values in each sampling zone (AASHTO T206)  
BBS, from 137 (Rev. 8-99)



# SOIL BORING LOG

Page 1 of 1  
Date 5/29/84

ROUTE FAP 600 DESCRIPTION Traffic Signals at IL 159 and Ludwig Dr / Salem Pl LOGGED BY J. King  
SECTION 130TS LOCATION SE 1/4, SEC. 21, TWP. 2N, RNG. 8W, 3 PM  
COUNTY St. Clair DRILLING METHOD Hollow Stem Auger HAMMER TYPE 140# Automatic

STRUCT. NO. Station	D E P T H (ft)	B L O W S (/6")	U C S Qu (tsf)	M O I S T (%)	Surface Water Elev. _____ ft	Stream Bed Elev. _____ ft	Groundwater Elev.: First Encounter _____ ft	Upon Completion _____ ft	After _____ Hrs. _____ ft	D E P T H (ft)	B L O W S (/6")	U C S Qu (tsf)	M O I S T (%)
											7	1.4	25
												B	
		7	1.3	23							13	1.5	29
												B	
		4	1.3	20					562.9		8	1.2	28
												B	
		2	0.7	23									
												S	
		12	3.0	24									
												S	
		23	2.4	23									
												S	
		18	4.2	24									
												S	
		8	3.3	25									
												S	

The Unconfined Compressive Strength (UCS) Failure Mode is indicated by (B-Bulge, S-Shear, P-Penetrometer)  
The SPT (N value) is the sum of the last two blow values in each sampling zone (AASHTO T206)  
BBS, from 137 (Rev. 8-99)

MODEL: D:\soft\iteris\inc\systems\midwest - Chicago Construction\DOT\_PFB\_201-041\_DB ITS\12082 - IL 159 Signal & Interconnect\CADD\Sheet Files\0912082\_IL-Route 159\_Soil\_Borings.dgn



USER NAME = bfunk	DESIGNED - BF	REVISED -
	DRAWN - BF	REVISED -
PLOT SCALE = 100,0000' / in.	CHECKED - AD	REVISED -
PLOT DATE = 12/21/2023	DATE - 11/10/23	REVISED -

STATE OF ILLINOIS  
DEPARTMENT OF TRANSPORTATION

SOIL BORING LOGS  
IL ROUTE 159 AND LUDWIG DRIVE / SALEM PLACE

F.A.P. RTE.	SECTION	COUNTY	TOTAL SHEETS	SHEET NO.
600	(130, 130-1, 130-2/75-3, 82-575)	ST. CLAIR	47	13
CONTRACT NO. 76R78				
ILLINOIS FED. AID PROJECT				

**NOTES:**

- CONDUIT LENGTH DIMENSIONS SHOWN IN CALLOUT ARE ESTIMATED BASED ON FIELD MEASUREMENTS. LINE LENGTHS MAY NOT BE ACCURATE.
- PROPOSED MAST ARM LOCATIONS SHOWN WITH APPROXIMATE OFFSETS FROM EXISTING INFRASTRUCTURE. CONTRACTOR SHALL FIELD VERIFY THE FINAL MA LOCATIONS WITH THE ENGINEER BEFORE DRILLING.
- ALL UTILITIES PRESENT MAY NOT BE SHOWN. ALL UTILITIES SHOWN ARE APPROXIMATE. THE CONTRACTOR SHALL BE RESPONSIBLE FOR LOCATION, PROTECTION, AND COORDINATION OF EXISTING UTILITIES.
- ALL UNUSED AND/OR UNNECESSARY TRAFFIC SIGNAL CABLES SHALL BE COMPLETELY REMOVED FROM THE EXISTING CONDUIT SYSTEM, IF POSSIBLE, TO ENSURE ADEQUATE CONDUIT CAPACITY. ALL UNUSED CONDUITS SHALL BE REMOVED OR ABANDONED.
- PRIOR TO INSTALLING NEW TRAFFIC SIGNAL CABLES WITHIN EXISTING CONDUITS, THE CONTRACTOR SHALL BE RESPONSIBLE FOR DETERMINING IF NEW TRAFFIC SIGNAL CABLES CAN BE PULLED THROUGHOUT PERTINENT CONDUIT SEGMENTS WITHOUT AFFECTING THE OPERATION OF THE TRAFFIC SIGNAL. IF EXISTING CONDUIT CAPACITIES WILL PREVENT THE INSTALLATION OF THE NEW TRAFFIC SIGNAL CABLES WITHOUT AFFECTING THE OPERATION OF THE TRAFFIC SIGNAL, THE TRAFFIC SIGNAL WILL HAVE TO BE TEMPORARILY SHUT DOWN WHILE UNNECESSARY EXISTING SIGNAL CABLES ARE REMOVED AND NEW SIGNAL CABLES ARE INSTALLED.
- DENOTED EXISTING AND/OR PROPOSED CONDUITS SHALL BE UTILIZED TO ACCOMMODATE NEW SIGNAL CABLING REQUIRED FOR RELOCATION OF EXISTING TRAFFIC SIGNAL HEADS.
- DENOTED EXISTING CONDUITS CONTAIN CABLING FOR EXISTING VEHICULAR DETECTION LOOPS. NO MODIFICATION TO THE EXISTING STOP BAR AND/OR ADVANCED DETECTION LOOPS ARE ANTICIPATED AS PART OF THIS PROJECT. THE CONTRACTOR SHALL ENSURE THAT ALL VEHICULAR DETECTION LOOPS REMAIN FULLY OPERATIONAL AT ALL TIMES.
- TOPOGRAPHY SHOWN IS FROM EXISTING TRAFFIC SIGNAL PLANS, WITH SOME NOTES BEING FROM OLD PLANS. PROPOSED WORK IS SHOWN IN BOLD.

EX. INTERCONNECT CONDUIT TO LUDWIG DR / SALEM PL (SEE FIBER OPTIC PLANS)

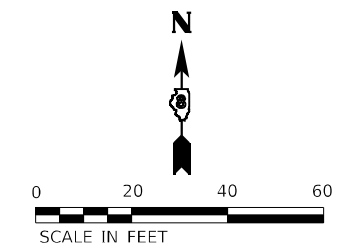
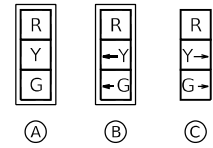

**PROPOSED CONTROLLER SEQUENCE**

SEQUENCE OF OPERATION								
PHASE	1	2	3	4	5	6	7	8
MOVEMENT	NOT USED	SB ↓	NOT USED	WB ↕	NOT USED	NB ↑	NOT USED	NOT USED
CONCURRENT MOVEMENT ALLOWED	NOT USED	6	NOT USED	NONE	NOT USED	2	NOT USED	NOT USED

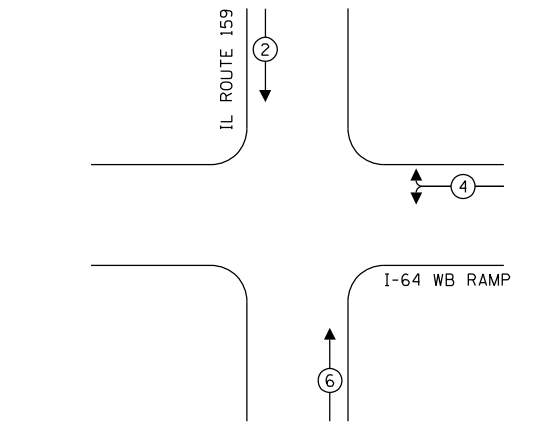
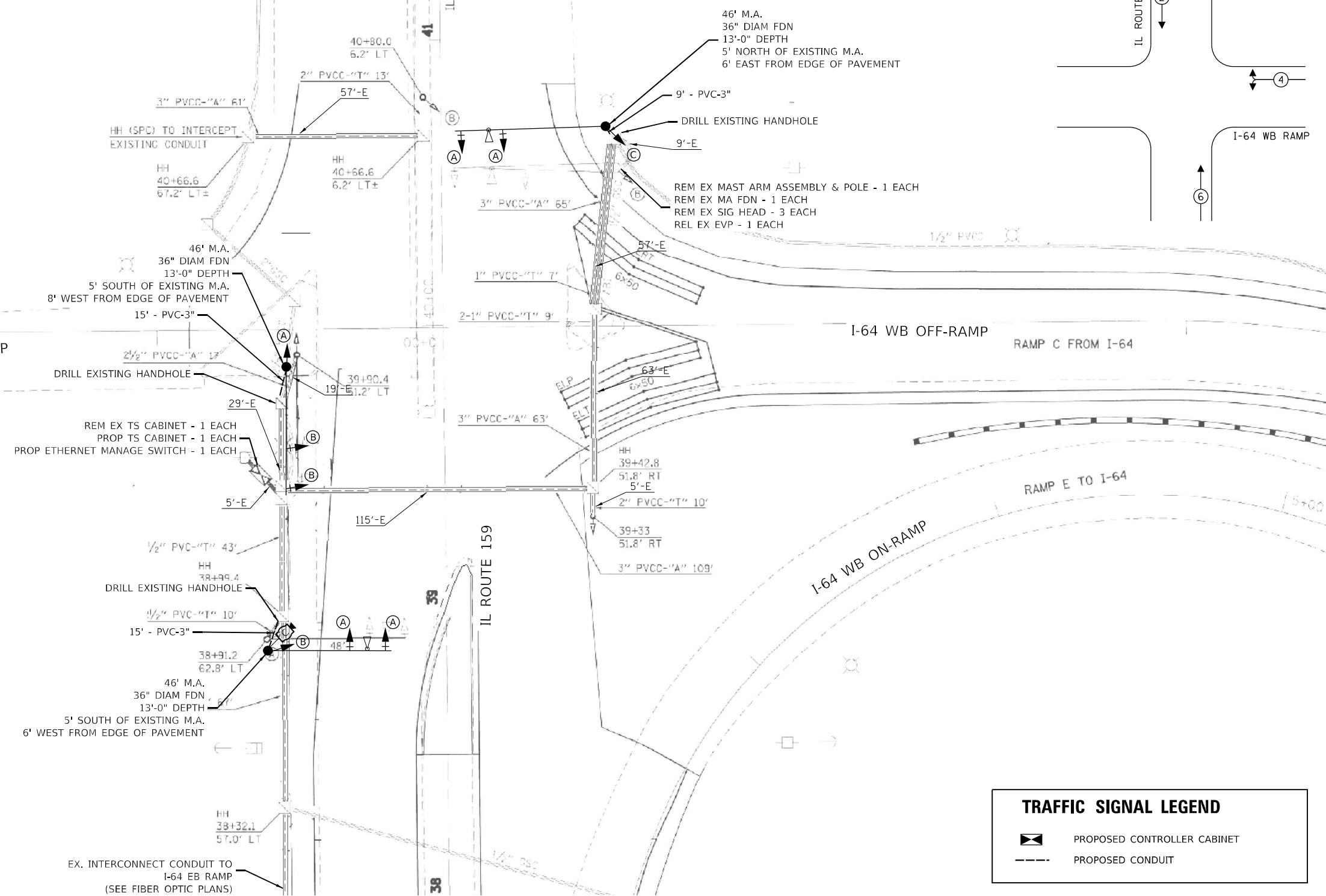

**TRAFFIC SIGNAL LEGEND**

- PROPOSED CONTROLLER CABINET
- PROPOSED CONDUIT

MODEL: D:\p\h\... FILE NAME: C:\Sharepoint\ITERIS, INC\Systems - Midwest - Chicago Construction\DOT\_PFB\_201-041\_DB ITS\12082 - IL 159 Signal & Interconnect\CADD\Sheet Files\0212082\_IL-Route 159\_TS\_SHT\_02184\_WB Ramps.dgn



USER NAME = bfunck	DESIGNED - AD	REVISED -
PLOT SCALE = 100,0000' / in.	DRAWN - AD	REVISED -
PLOT DATE = 12/21/2023	CHECKED - BF	REVISED -
	DATE - 11/6/23	REVISED -

**STATE OF ILLINOIS  
DEPARTMENT OF TRANSPORTATION**

**TRAFFIC SIGNAL MODIFICATION PLAN  
IL ROUTE 159 AND I-64 WB RAMPS**

SCALE: SHEET OF SHEETS STA. TO STA.

F.A.P. RTE.	SECTION	COUNTY	TOTAL SHEETS	SHEET NO.
600	(130, 130-1, 130-2)TS-3, 82-575	ST. CLAIR	47	14
ILLINOIS FED. AID PROJECT			CONTRACT NO. 76R78	

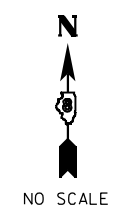

TRAFFIC SIGNAL LEGEND	
	PROP. TRAFFIC SIGNAL CONTROLLER
	PROP. CCTV CAMERA
	PROP. GROUNDING
	PROP. NO. OF CONDUCTORS IN CABLE
	PROP. CCTV CABLE
	PROP. 12" SIGNAL HEAD
	EX. VEHICLE DETECTOR, INDUCTION LOOP
	EX. NO. OF CONDUCTORS IN CABLE
	EX. 12" SIGNAL HEAD
	EX. GROUND MOUNT SERVICE
	EX. GROUNDING
	EX. EMERGENCY VEHICLE PREEMPTION
	EX. CONFIRMATION BEACON

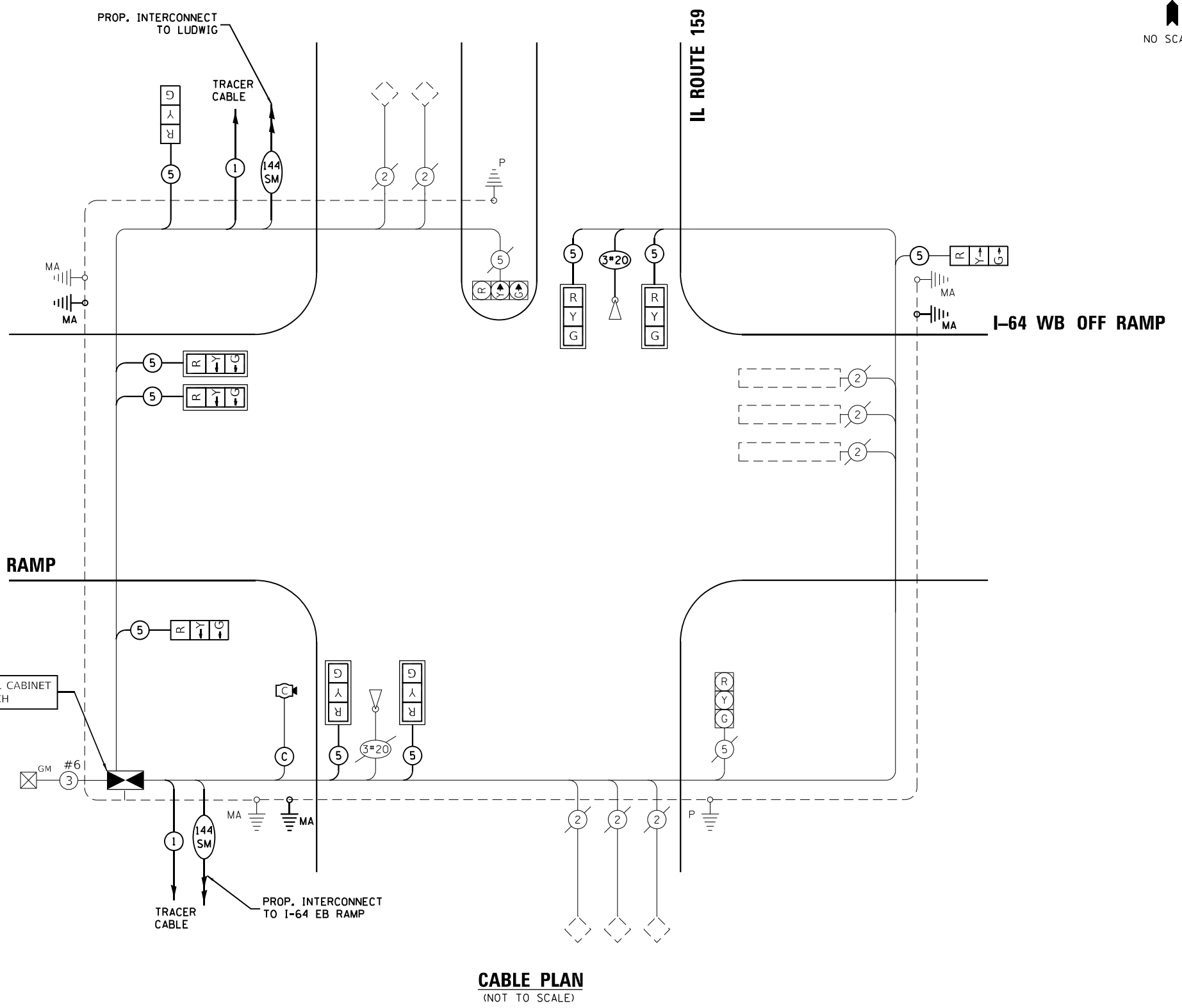

**SCHEDULE OF QUANTITIES**

ITEM DESCRIPTION	UNIT	QTY.
LOCATING UNDERGROUND CABLE	FOOT	10
UNDERGROUND CONDUIT, PVC, 3" DIA.	FOOT	39
MAINTENANCE OF EXISTING TRAFFIC SIGNAL INSTALLATION	EACH	1
FULL-ACTUATED CONTROLLER AND TYPE IV CABINET	EACH	1
UNINTERRUPTABLE POWER SUPPLY, EXTENDED	EACH	1
ELECTRIC CABLE IN CONDUIT, SIGNAL NO. 14 5C	FOOT	1737
ELECTRIC CABLE IN CONDUIT, EQUIPMENT GROUNDING CONDUCTOR, NO. 6 1C	FOOT	50
STEEL MAST ARM ASSEMBLY AND POLE, 46 FT.	EACH	3
CONCRETE FOUNDATION, TYPE E 36-INCH DIAMETER	FOOT	39
DRILL EXISTING HANDHOLE	EACH	3
SIGNAL HEAD, LED, 1-FACE, 3-SECTION, MAST-ARM MOUNTED	EACH	6
TRAFFIC SIGNAL BACKPLATE, RETROREFLECTIVE	EACH	6
RELOCATE EXISTING TRAFFIC SIGNAL EQUIPMENT	EACH	1
* REMOVE ELECTRIC CABLE FROM CONDUIT	FOOT	500
REMOVE EXISTING TRAFFIC SIGNAL EQUIPMENT	EACH	1
REMOVE EXISTING CONCRETE FOUNDATION	EACH	3
EMERGENCY VEHICLE PRIORITY SYSTEM LINE SENSOR CABLE, NO. 20 3/C	FOOT	490
ETHERNET MANAGE SWITCH	EACH	1
CLOSED CIRCUIT TELEVISION DOME CAMERA, HD	EACH	1

\* NOMINAL QUANTITY TO BE USED AS NEEDED AND AS APPROVED BY ENGINEER

**CABLE PLAN**  
(NOT TO SCALE)

MODEL: Default  
 FILE NAME: C:\Sharepoint\ITERIS - INC\Systems - Midwest - Chicago Construction\DOT PBE\_201-041\_DB ITS\12082 - IL 159 Signal & Interconnect\CADD\Sheet Files\IL159\_Cable\_SHT\_02.R64\_V18\_Ramps.dgn



USER NAME = bfunck	DESIGNED - AD	REVISED -
PLOT SCALE = 100,0000' / in.	DRAWN - AD	REVISED -
PLOT DATE = 12/22/2023	CHECKED - BF	REVISED -
	DATE - 12/22/23	REVISED -

**STATE OF ILLINOIS**  
**DEPARTMENT OF TRANSPORTATION**

**TRAFFIC SIGNAL CABLE PLAN**  
**IL ROUTE 159 AND I-64 WB RAMPS**

F.A.P. RTE.	SECTION	COUNTY	TOTAL SHEETS	SHEET NO.
600	(130, 130-1, 130-2)TS-3, 82-575	ST. CLAIR	47	15
CONTRACT NO. 76R78				
ILLINOIS FED. AID PROJECT				

SCALE: SHEET OF SHEETS STA. TO STA.



### TRAFFIC SIGNAL LEGEND

- PROPOSED CONTROLLER CABINET
- VIDEO DETECTION UNIT
- VIDEO/RADAR DETECTION ZONE
- PROPOSED CONDUIT

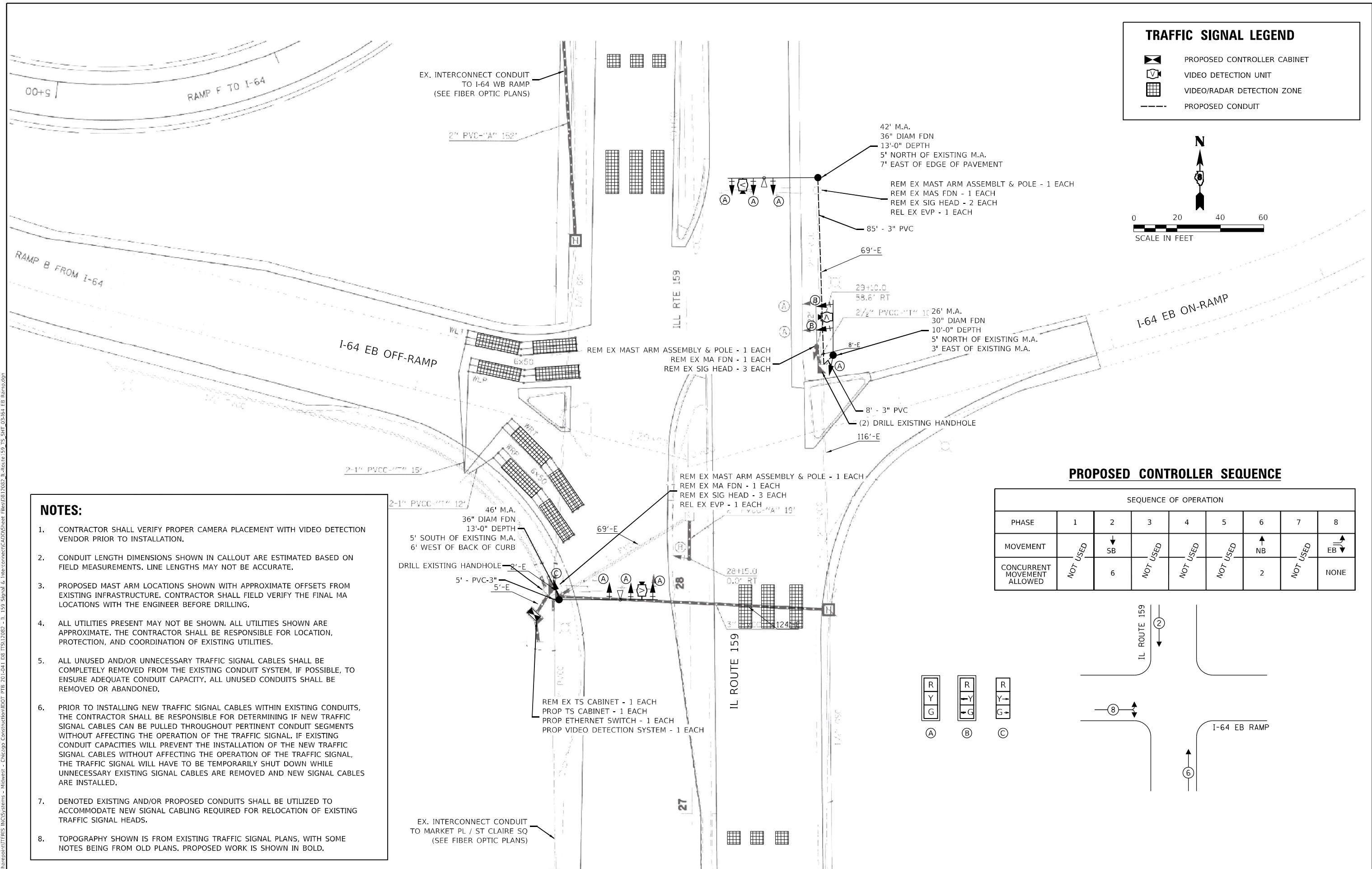
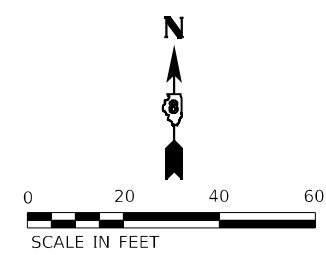

- ### NOTES:
- CONTRACTOR SHALL VERIFY PROPER CAMERA PLACEMENT WITH VIDEO DETECTION VENDOR PRIOR TO INSTALLATION.
  - CONDUIT LENGTH DIMENSIONS SHOWN IN CALLOUT ARE ESTIMATED BASED ON FIELD MEASUREMENTS. LINE LENGTHS MAY NOT BE ACCURATE.
  - PROPOSED MAST ARM LOCATIONS SHOWN WITH APPROXIMATE OFFSETS FROM EXISTING INFRASTRUCTURE. CONTRACTOR SHALL FIELD VERIFY THE FINAL MA LOCATIONS WITH THE ENGINEER BEFORE DRILLING.
  - ALL UTILITIES PRESENT MAY NOT BE SHOWN. ALL UTILITIES SHOWN ARE APPROXIMATE. THE CONTRACTOR SHALL BE RESPONSIBLE FOR LOCATION, PROTECTION, AND COORDINATION OF EXISTING UTILITIES.
  - ALL UNUSED AND/OR UNNECESSARY TRAFFIC SIGNAL CABLES SHALL BE COMPLETELY REMOVED FROM THE EXISTING CONDUIT SYSTEM, IF POSSIBLE, TO ENSURE ADEQUATE CONDUIT CAPACITY. ALL UNUSED CONDUITS SHALL BE REMOVED OR ABANDONED.
  - PRIOR TO INSTALLING NEW TRAFFIC SIGNAL CABLES WITHIN EXISTING CONDUITS, THE CONTRACTOR SHALL BE RESPONSIBLE FOR DETERMINING IF NEW TRAFFIC SIGNAL CABLES CAN BE PULLED THROUGHOUT PERTINENT CONDUIT SEGMENTS WITHOUT AFFECTING THE OPERATION OF THE TRAFFIC SIGNAL. IF EXISTING CONDUIT CAPACITIES WILL PREVENT THE INSTALLATION OF THE NEW TRAFFIC SIGNAL CABLES WITHOUT AFFECTING THE OPERATION OF THE TRAFFIC SIGNAL, THE TRAFFIC SIGNAL WILL HAVE TO BE TEMPORARILY SHUT DOWN WHILE UNNECESSARY EXISTING SIGNAL CABLES ARE REMOVED AND NEW SIGNAL CABLES ARE INSTALLED.
  - DENOTED EXISTING AND/OR PROPOSED CONDUITS SHALL BE UTILIZED TO ACCOMMODATE NEW SIGNAL CABLING REQUIRED FOR RELOCATION OF EXISTING TRAFFIC SIGNAL HEADS.
  - TOPOGRAPHY SHOWN IS FROM EXISTING TRAFFIC SIGNAL PLANS, WITH SOME NOTES BEING FROM OLD PLANS. PROPOSED WORK IS SHOWN IN BOLD.

### PROPOSED CONTROLLER SEQUENCE

SEQUENCE OF OPERATION								
PHASE	1	2	3	4	5	6	7	8
MOVEMENT	NOT USED	↓ SB	NOT USED	NOT USED	NOT USED	↑ NB	NOT USED	↕ EB
CONCURRENT MOVEMENT ALLOWED	NOT USED	6	NOT USED	NOT USED	NOT USED	2	NOT USED	NONE

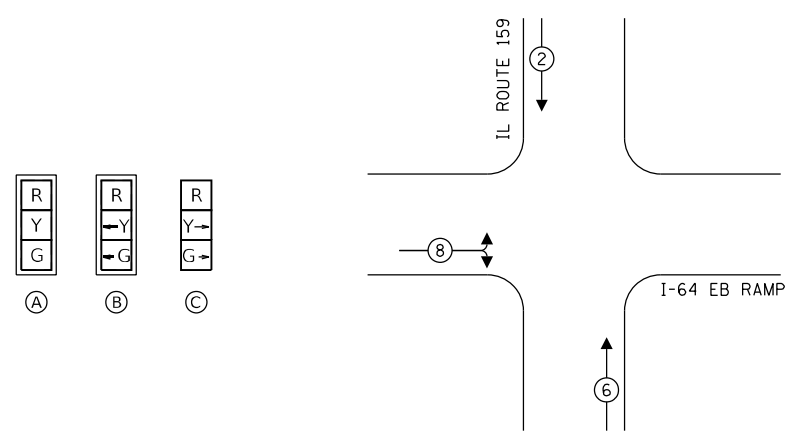

MODEL: Default  
 FILE NAME: C:\Sharepoint\ITERIS - Midwest - Chicago Construction\DOT\_PFB\_201-041\_D8 ITS\12082 - IL 159 Signal & Interconnect\CAD\Sheet Files\12082\_IL-Route 159\_TS\_SHT\_03164\_EB\_Ramp.dgn  
 MODEL: Default  
 FILE NAME: C:\Sharepoint\ITERIS - Midwest - Chicago Construction\DOT\_PFB\_201-041\_D8 ITS\12082 - IL 159 Signal & Interconnect\CAD\Sheet Files\12082\_IL-Route 159\_TS\_SHT\_03164\_EB\_Ramp.dgn



USER NAME = bfunk	DESIGNED - AD	REVISED -
	DRAWN - AD	REVISED -
PLOT SCALE = 100,0000' / in.	CHECKED - BF	REVISED -
PLOT DATE = 12/21/2023	DATE - 11/6/23	REVISED -

**STATE OF ILLINOIS**  
**DEPARTMENT OF TRANSPORTATION**

**TRAFFIC SIGNAL MODIFICATION PLAN**  
**IL ROUTE 159 AND I-64 EB RAMPS**

SCALE: SHEET OF SHEETS STA. TO STA.

F.A.P. RTE.	SECTION	COUNTY	TOTAL SHEETS	SHEET NO.
600	(130, 130-1, 130-2)/TS-3, 82-575	ST. CLAIR	47	17
CONTRACT NO. 76R78				
ILLINOIS / FED. AID PROJECT				

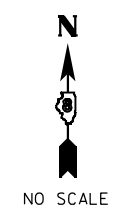

TRAFFIC SIGNAL LEGEND	
	PROP. TRAFFIC SIGNAL CONTROLLER
	PROP. CCTV CAMERA
	PROP. GROUNDING
	PROP. NO. OF CONDUCTORS IN CABLE
	PROP. CCTV CABLE
	PROP. 12" SIGNAL HEAD
	EX. VEHICLE DETECTOR, INDUCTION LOOP
	EX. NO. OF CONDUCTORS IN CABLE
	EX. 12" SIGNAL HEAD
	EX. GROUND MOUNT SERVICE
	EX. GROUNDING
	EX. EMERGENCY VEHICLE PREEMPTION
	EX. CONFIRMATION BEACON

I-64 EB OFF RAMP

IL ROUTE 159

I-64 EB ON RAMP

**SCHEDULE OF QUANTITIES**

ITEM DESCRIPTION	UNIT	QTY.
LOCATING UNDERGROUND CABLE	FOOT	10
UNDERGROUND CONDUIT, PVC, 3" DIA.	FOOT	98
MAINTENANCE OF EXISTING TRAFFIC SIGNAL INSTALLATION	EACH	1
FULL-ACTUATED CONTROLLER AND TYPE IV CABINET	EACH	1
UNINTERRUPTABLE POWER SUPPLY, EXTENDED	EACH	1
ELECTRIC CABLE IN CONDUIT, SIGNAL NO. 14 5C	FOOT	2433
ELECTRIC CABLE IN CONDUIT, EQUIPMENT GROUNDING CONDUCTOR, NO. 6 1C	FOOT	133
STEEL MAST ARM ASSEMBLY AND POLE, 26 FT.	EACH	1
STEEL MAST ARM ASSEMBLY AND POLE, 42 FT.	EACH	1
STEEL MAST ARM ASSEMBLY AND POLE, 46 FT.	EACH	1
CONCRETE FOUNDATION, TYPE E 30-INCH DIAMETER	FOOT	10
CONCRETE FOUNDATION, TYPE E 36-INCH DIAMETER	FOOT	26
DRILL EXISTING HANDHOLE	EACH	3
SIGNAL HEAD, LED, 1-FACE, 3-SECTION, MAST-ARM MOUNTED	EACH	8
SIGNAL HEAD, LED, 1-FACE, 3-SECTION, BRACKET MOUNTED	EACH	2
TRAFFIC SIGNAL BACKPLATE, RETROREFLECTIVE	EACH	8
RELOCATE EXISTING TRAFFIC SIGNAL EQUIPMENT	EACH	1
* REMOVE ELECTRIC CABLE FROM CONDUIT	FOOT	500
REMOVE EXISTING TRAFFIC SIGNAL EQUIPMENT	EACH	1
REMOVE EXISTING CONCRETE FOUNDATION	EACH	3
EMERGENCY VEHICLE PRIORITY SYSTEM LINE SENSOR CABLE, NO. 20 3/C	FOOT	504
VIDEO DETECTION SYSTEM	EACH	1
ETHERNET SWITCH	EACH	1

\* NOMINAL QUANTITY TO BE USED AS NEEDED AND AS APPROVED BY ENGINEER

REPLACE EXISTING TRAFFIC SIGNAL CABINET  
INSTALL ETHERNET SWITCH  
INSTALL VIDEO DETECTION SYSTEM

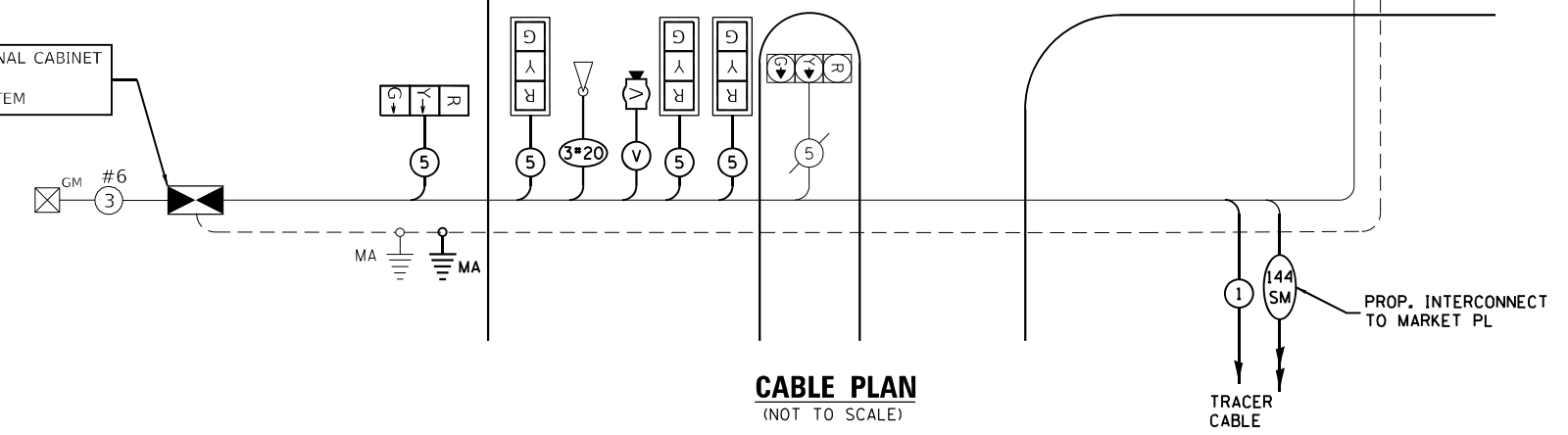

**CABLE PLAN**  
(NOT TO SCALE)

MODEL: Default  
FILE NAME: C:\Sharepoint\ITERIS - INC\Systems - Midwest - Chicago Construction\DOT\_PFB\_201-041\_D8 ITS12082 - IL 159 Signal & Interconnect\CADD\Sheet Files\IL159\_Cable\_SHT\_03\_I64\_EB\_Ramp.dgn



USER NAME = bfunck	DESIGNED - AD	REVISED -
PLOT SCALE = 100,0000' / in.	DRAWN - AD	REVISED -
PLOT DATE = 2/27/2024	CHECKED - BF	REVISED -
	DATE - 2/26/24	REVISED -

**STATE OF ILLINOIS**  
**DEPARTMENT OF TRANSPORTATION**

<b>TRAFFIC SIGNAL CABLE PLAN</b>			
<b>IL ROUTE 159 AND I-64 EB RAMPS</b>			
SCALE:	SHEET	OF SHEETS	STA. TO STA.

F.A.P. RTE.	SECTION	COUNTY	TOTAL SHEETS	SHEET NO.
600	(130, 130-1, 130-2)TS-3, 82-575	ST. CLAIR	47	18
CONTRACT NO. 76R78			ILLINOIS FED. AID PROJECT	



ILLINOIS DEPARTMENT OF TRANSPORTATION  
 District Eight Materials Depth Increment = 152.5mm  
 NW 1/4, NW 1/4, SECTION 27, T 2 N, R 8 W, 3RD PM

Bridge Foundation  
 Boring Log

PROJECT FAI 64 BRIDGE I 64 - IL 159 Date 09/30/96 Sh. 1 of 1  
 INTERCHANGE  
 ROUTE FAI 64 Bored By JOSEPH MONROE  
 SEC. 82-5KI STA. Checked By MARY LAMIE

COUNTY St. Clair  
 Street No.  
 Boring No. 4  
 Sta 1+236.4  
 O/S 21.8m RT.

El.	N	Qu kPa	W %	Surf Wat El. Grndwater El. at Compl	At	Hrs	El.	N	Qu kPa	W %	
Ground Surface 180.02 0m											
BROWN AND GRAY SILT											
							-7				
	4										
	6										
	9	187.28	18								
	3										
	6										
	9	156.06	17								
	8										
	9						-9				
	11	NC	17								
	8										
	11										
	15	234.10	16								
	7										
	11										
	13	171.67	17				11				
	4										
	6										
	8	131.09	21								
	1										
	2										
	2	18.73	28								
	2										
	3										
	5	49.94	26				13				
173.62 END OF BORING											
N 50 mm OD Sampler, Driven 305 mm 63.5Kg Hammer, 760 mm Fall (F.W.-Free Water B-Bulge S-Shear)											

ILLINOIS DEPARTMENT OF TRANSPORTATION  
 District Eight Materials Depth Increment = 152.5mm  
 NE 1/4, NE 1/4, SECTION 28, T 2 N, R 8 W, 3RD PM

Bridge Foundation  
 Boring Log

PROJECT FAI 64 BRIDGE I 64 - IL 159 Date 09/30/96 Sh. 1 of 1  
 INTERCHANGE  
 ROUTE FAI 64 Bored By JOSEPH MONROE  
 SEC. 82-5KI STA. Checked By MARY LAMIE

COUNTY St. Clair  
 Street No.  
 Boring No. 5  
 Sta 1+206.2  
 O/S 15m LT.

El.	N	Qu kPa	W %	Surf Wat El. Grndwater El. at Compl	At	Hrs	El.	N	Qu kPa	W %	
Ground Surface 180.92 0m											
BROWN SILT											
							-7				
	9										
	11										
	15	280.92	15								
	4										
	5										
	6	156.06	20								
	5										
	7						-9				
	12	124.85	19								
	6										
	7										
	12	265.31	17								
	10										
	16										
	16	327.74	16				11				
	7										
	9										
	15	249.70	16								
	16										
	18										
	23	280.92	17								
	7										
	11										
	11	265.31	17				13				
174.52 END OF BORING											
N 50 mm OD Sampler, Driven 305 mm 63.5Kg Hammer, 760 mm Fall (F.W.-Free Water B-Bulge S-Shear)											

MODEL Default  
 FILE NAME C:\Sharepoint\ITERIS, INC\Systems - Midwest - Chicago Construction\DOT\_PFB\_201-041\_DB ITS\12082 - IL 159 Signal & Interconnect\CADD\Sheet Files\0812082\_IL-Route 159\_Soil\_Borings.dgn



USER NAME = bfunk	DESIGNED - BF	REVISED -
DRAWN - BF	REVISED -	
PLOT SCALE = 100,0000 ' / in.	CHECKED - AD	REVISED -
PLOT DATE = 12/21/2023	DATE - 11/10/23	REVISED -

STATE OF ILLINOIS  
 DEPARTMENT OF TRANSPORTATION

SOIL BORING LOGS			
IL ROUTE 159 AND I-64 EB RAMPS			
SCALE:	SHEET	OF SHEETS	STA. TO STA.

F.A.P. RTE.	SECTION	COUNTY	TOTAL SHEETS	SHEET NO.
600	(130, 130-1, 130-2/TS-3, 82-5TS)	ST. CLAIR	47	20
CONTRACT NO. 76R78				
ILLINOIS FED. AID PROJECT				



**PROPOSED CONTROLLER SEQUENCE**

SEQUENCE OF OPERATION								
PHASE	1	2	3	4	5	6	7	8
MOVEMENT	NB LT	SB	WB	EB	SB LT	NB	NOT USED	NOT USED
CONCURRENT MOVEMENT ALLOWED	5 OR 6	5 OR 6	NONE	NONE	1 OR 2	1 OR 2	NOT USED	NOT USED

**TRAFFIC SIGNAL LEGEND**

- PROPOSED CONTROLLER CABINET
- VIDEO DETECTION UNIT
- VIDEO/RADAR DETECTION ZONE
- PROPOSED CONDUIT

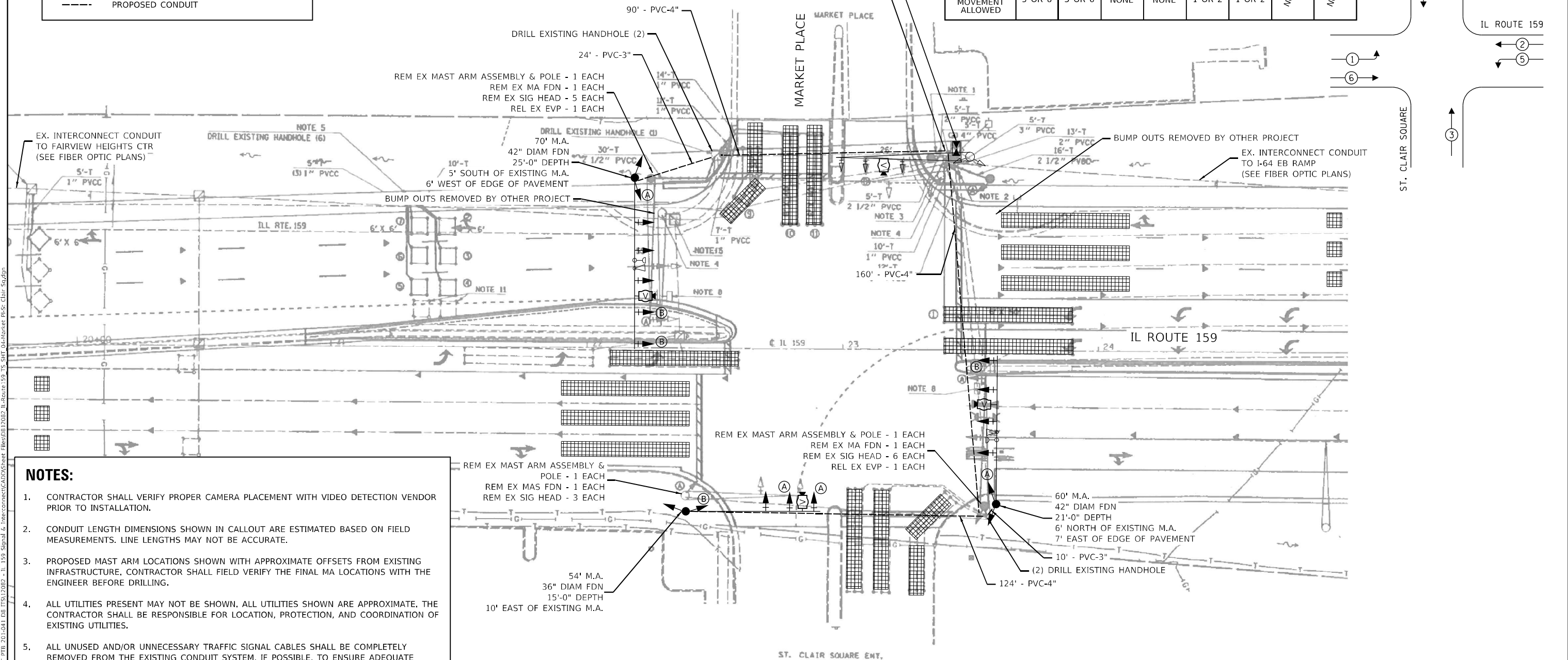

- NOTES:**
- CONTRACTOR SHALL VERIFY PROPER CAMERA PLACEMENT WITH VIDEO DETECTION VENDOR PRIOR TO INSTALLATION.
  - CONDUIT LENGTH DIMENSIONS SHOWN IN CALLOUT ARE ESTIMATED BASED ON FIELD MEASUREMENTS. LINE LENGTHS MAY NOT BE ACCURATE.
  - PROPOSED MAST ARM LOCATIONS SHOWN WITH APPROXIMATE OFFSETS FROM EXISTING INFRASTRUCTURE. CONTRACTOR SHALL FIELD VERIFY THE FINAL MA LOCATIONS WITH THE ENGINEER BEFORE DRILLING.
  - ALL UTILITIES PRESENT MAY NOT BE SHOWN. ALL UTILITIES SHOWN ARE APPROXIMATE. THE CONTRACTOR SHALL BE RESPONSIBLE FOR LOCATION, PROTECTION, AND COORDINATION OF EXISTING UTILITIES.
  - ALL UNUSED AND/OR UNNECESSARY TRAFFIC SIGNAL CABLES SHALL BE COMPLETELY REMOVED FROM THE EXISTING CONDUIT SYSTEM, IF POSSIBLE, TO ENSURE ADEQUATE CONDUIT CAPACITY. ALL UNUSED CONDUITS SHALL BE REMOVED OR ABANDONED.
  - PRIOR TO INSTALLING NEW TRAFFIC SIGNAL CABLES WITHIN EXISTING CONDUITS, THE CONTRACTOR SHALL BE RESPONSIBLE FOR DETERMINING IF NEW TRAFFIC SIGNAL CABLES CAN BE PULLED THROUGHOUT PERTINENT CONDUIT SEGMENTS WITHOUT AFFECTING THE OPERATION OF THE TRAFFIC SIGNAL. IF EXISTING CONDUIT CAPACITIES WILL PREVENT THE INSTALLATION OF THE NEW TRAFFIC SIGNAL CABLES WITHOUT AFFECTING THE OPERATION OF THE TRAFFIC SIGNAL, THE TRAFFIC SIGNAL WILL HAVE TO BE TEMPORARILY SHUT DOWN WHILE UNNECESSARY EXISTING SIGNAL CABLES ARE REMOVED AND NEW SIGNAL CABLES ARE INSTALLED.
  - DENOTED EXISTING AND/OR PROPOSED CONDUITS SHALL BE UTILIZED TO ACCOMMODATE NEW SIGNAL CABLING REQUIRED FOR RELOCATION OF EXISTING TRAFFIC SIGNAL HEADS.
  - TOPOGRAPHY SHOWN IS FROM EXISTING TRAFFIC SIGNAL PLANS, WITH SOME NOTES BEING FROM OLD PLANS. PROPOSED WORK IS SHOWN IN BOLD.

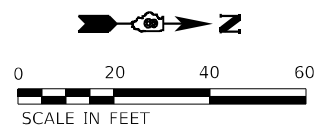
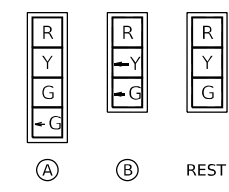

MODEL: Default  
 FILE NAME: C:\Sharepoint\ITERIS, INC\Systems - Midwest - Chicago Construction\IBDOT\_PFB\_201-041\_D8 ITS\12082 - IL 159 Signal & Interconnect\CADD\Sheet Files\0812082\_ILRoute159\_TS\_SMT\_OutMarket\_PL5- Clair\_Sq.dgn



USER NAME = bfunk	DESIGNED - AD	REVISED -
	DRAWN - AD	REVISED -
PLOT SCALE = 100,0000' / in.	CHECKED - BF	REVISED -
PLOT DATE = 2/26/2024	DATE - 11/6/23	REVISED -

**STATE OF ILLINOIS  
DEPARTMENT OF TRANSPORTATION**

**TRAFFIC SIGNAL MODIFICATION PLAN  
IL ROUTE 159 AND MARKET PLACE / ST. CLAIR SQUARE**

SCALE: SHEET OF SHEETS STA. TO STA.

F.A.P. RTE. 600	SECTION (130, 130-1, 130-2/TS-3, 82-575)	COUNTY ST. CLAIR	TOTAL SHEETS 47	SHEET NO. 22
CONTRACT NO. 76R78			ILLINOIS FED. AID PROJECT	

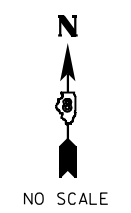

TRAFFIC SIGNAL LEGEND	
	PROP. TRAFFIC SIGNAL CONTROLLER
	PROP. CCTV CAMERA
	PROP. GROUNDING
	PROP. NO. OF CONDUCTORS IN CABLE
	PROP. CCTV CABLE
	PROP. 12" SIGNAL HEAD
	EX. VEHICLE DETECTOR, INDUCTION LOOP
	EX. NO. OF CONDUCTORS IN CABLE
	EX. 12" SIGNAL HEAD
	EX. GROUND MOUNT SERVICE
	EX. GROUNDING
	EX. EMERGENCY VEHICLE PREEMPTION
	EX. CONFIRMATION BEACON

REPLACE EXISTING TRAFFIC SIGNAL CABINET  
 INSTALL ETHERNET SWITCH  
 INSTALL VIDEO DETECTION SYSTEM

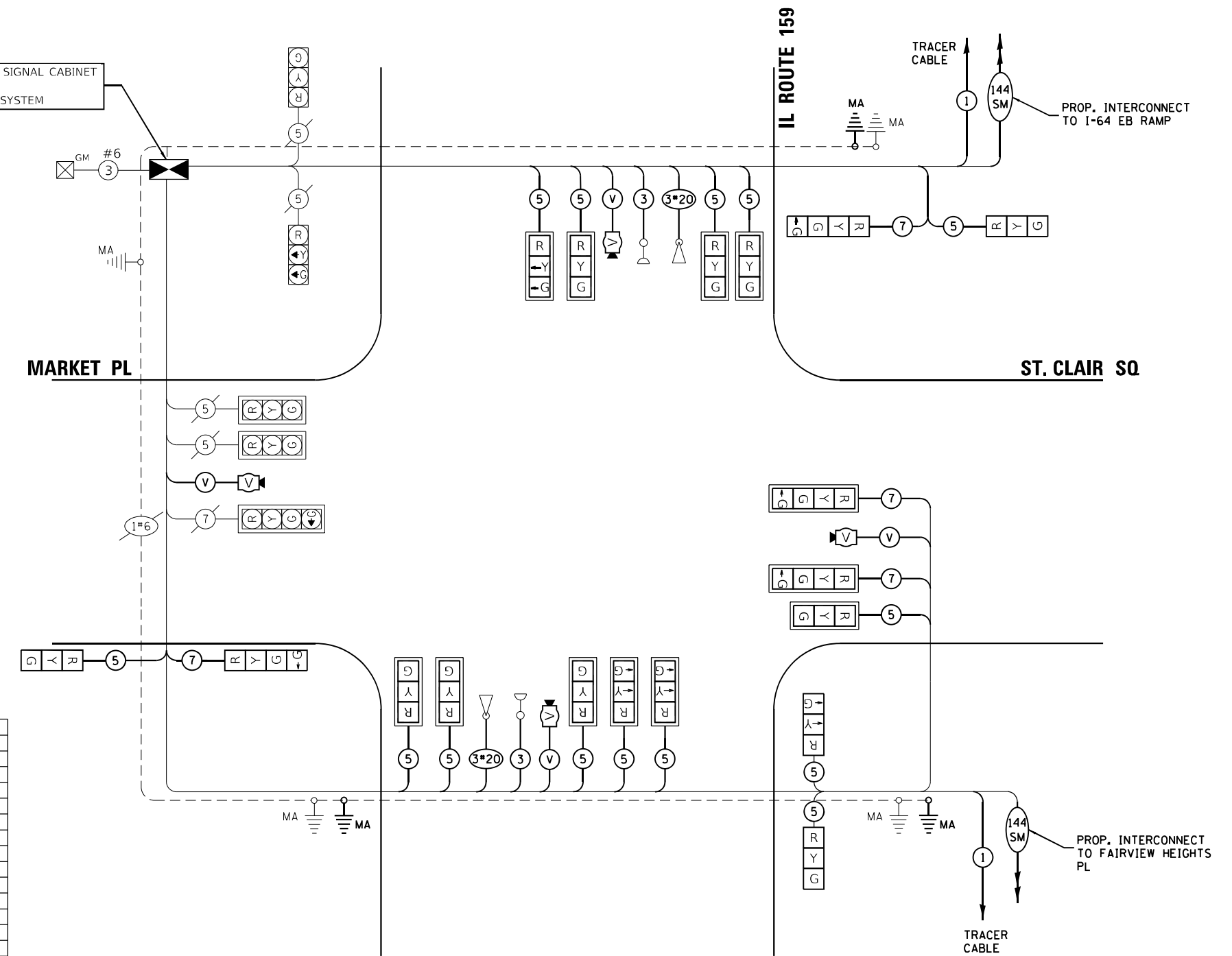

**CABLE PLAN**  
 (NOT TO SCALE)

**SCHEDULE OF QUANTITIES**

ITEM DESCRIPTION	UNIT	QTY.
RELOCATE SIGN PANEL - TYPE 1	50 FT	36
LOCATING UNDERGROUND CABLE	FOOT	10
UNDERGROUND CONDUIT, PVC, 3" DIA.	FOOT	34
UNDERGROUND CONDUIT, PVC, 4" DIA.	FOOT	374
MAINTENANCE OF EXISTING TRAFFIC SIGNAL INSTALLATION	EACH	1
FULL-ACTUATED CONTROLLER AND TYPE IV CABINET	EACH	1
UNINTERRUPTABLE POWER SUPPLY, EXTENDED	EACH	1
ELECTRIC CABLE IN CONDUIT, SIGNAL NO. 14 3C	FOOT	472
ELECTRIC CABLE IN CONDUIT, SIGNAL NO. 14 5C	FOOT	3506
ELECTRIC CABLE IN CONDUIT, SIGNAL NO. 14 7C	FOOT	1161
ELECTRIC CABLE IN CONDUIT, EQUIPMENT GROUNDING CONDUCTOR, NO. 6 1C	FOOT	193
STEEL MAST ARM ASSEMBLY AND POLE, 54 FT.	EACH	1
STEEL MAST ARM ASSEMBLY AND POLE, 60 FT.	EACH	1
STEEL MAST ARM ASSEMBLY AND POLE, 70 FT.	EACH	1
CONCRETE FOUNDATION, TYPE E 36-INCH DIAMETER	FOOT	15
CONCRETE FOUNDATION, TYPE E 42-INCH DIAMETER	FOOT	46
DRILL EXISTING HANDHOLE	EACH	6
SIGNAL HEAD, LED, 1-FACE, 3-SECTION, MAST-ARM MOUNTED	EACH	10
SIGNAL HEAD, LED, 1-FACE, 3-SECTION, BRACKET MOUNTED	EACH	4
SIGNAL HEAD, LED, 1-FACE, 4-SECTION, BRACKET MOUNTED	EACH	2
SIGNAL HEAD, LED, 1-FACE, 4-SECTION, MAST ARM MOUNTED	EACH	2
TRAFFIC SIGNAL BACKPLATE, RETROREFLECTIVE	EACH	12
RELOCATE EXISTING TRAFFIC SIGNAL EQUIPMENT	EACH	1
* REMOVE ELECTRIC CABLE FROM CONDUIT	FOOT	500
REMOVE EXISTING TRAFFIC SIGNAL EQUIPMENT	EACH	1
REMOVE EXISTING CONCRETE FOUNDATION	EACH	4
EMERGENCY VEHICLE PRIORITY SYSTEM LINE SENSOR CABLE, NO. 20 3/C	FOOT	472
VIDEO DETECTION SYSTEM	EACH	1
ETHERNET SWITCH	EACH	1

\* NOMINAL QUANTITY TO BE USED AS NEEDED AND AS APPROVED BY ENGINEER

MODEL: Default  
 FILE NAME: C:\Sharepoint\ITERIS - Midwest - Chicago Construction\DOT\_FPB\_201-041\_D8\_ITS\12082 - IL 159 Signal & Interconnect\CADD\Sheet Files\0912082\_ILRoute159\_Cable\_SHT\_044Market\_PLSt\_Clar\_Sq.dgn



USER NAME = bfunck	DESIGNED - AD	REVISED -
PLOT SCALE = 100,0000' / in.	CHECKED - BF	REVISED -
PLOT DATE = 2/27/2024	DATE - 2/26/24	REVISED -

**STATE OF ILLINOIS**  
**DEPARTMENT OF TRANSPORTATION**

**TRAFFIC SIGNAL CABLE PLAN**  
**IL ROUTE 159 AND MARKET PLACE /ST. CLAIR SQUARE**

F.A.P. RTE.	SECTION	COUNTY	TOTAL SHEETS	SHEET NO.
600	(130, 130-1, 130-2)TS-3, 82-575	ST. CLAIR	47	23
CONTRACT NO. 76R78				
ILLINOIS FED. AID PROJECT				

SCALE: SHEET OF SHEETS STA. TO STA.



# SOIL BORING LOG

Date 1/22/01

ROUTE FAP 600 DESCRIPTION Traffic Signals at IL 159 and Market Place / Mall Entrance in Fairview Heights LOGGED BY Brett Schwalb

SECTION 130-1RS, 130-11-TS-2 LOCATION NW 1/4, SEC. 27, TWP. 2N, RNG. 8W, 3 PM

COUNTY St. Clair DRILLING METHOD Hand Auger HAMMER TYPE DCP

STRUCT. NO. Station	D E P T H  (ft)	B L O W S  (/6")	U C S  Qu (tsf)	M O I S T  (%)	Surface Water Elev. _____ ft Stream Bed Elev. _____ ft  Groundwater Elev.: First Encounter 574.1 ft ▼ Upon Completion _____ ft After _____ Hrs. _____ ft
Brown and Black LOAM			1.0	20	
		8	1.75	23	
			1.75	30	
577.6					
Brown Clay LOAM		8	2.0	27	
576.6			0.75	28	
Brown Yellow CLAY		-5	0.5	31	
574.6		7	0.8	31	
Gray Yellow CLAY			1.25	29	
572.6		7	0.5	31	
Gray Silty CLAY					
571.6					
End of Hand Auger	-10				
Pocket Penetrometer used for Qu					
"N" values shown are calibrated from a curve converting dynamic cone N to SPT "N". Reference ASTM STP 399					
The blows to set the DCP are not included in the blow count.					
	-15				
	-20				

The Unconfined Compressive Strength (UCS) Failure Mode is indicated by (B-Bulge, S-Shear, P-Penetrometer)  
The SPT (N value) is the sum of the last two blow values in each sampling zone (AASHTO T206)

BBS, from 137 (Rev. 8-99)



# SOIL BORING LOG

Date 1/22/01

ROUTE FAP 600 DESCRIPTION Traffic Signals at IL 159 and Market Place / Mall Entrance in Fairview Heights LOGGED BY Brett Schwalb

SECTION 130-1RS, 130-11-TS-2 LOCATION NW 1/4, SEC. 27, TWP. 2N, RNG. 8W, 3 PM

COUNTY St. Clair DRILLING METHOD Hand Auger HAMMER TYPE DCP

STRUCT. NO. Station	D E P T H  (ft)	B L O W S  (/6")	U C S  Qu (tsf)	M O I S T  (%)	Surface Water Elev. _____ ft Stream Bed Elev. _____ ft  Groundwater Elev.: First Encounter 573.9 ft ▼ Upon Completion _____ ft After _____ Hrs. _____ ft
Brown/Yellow Silty LOAM			No	20	
579.9					
Black LOAM		5	0.75	25	
578.9			2.0	27	
Brown/Yellow Clay LOAM			2.25	28	
576.9		8	1.0	29	
Yellow Silty CLAY		-5	0.75	32	
574.9		7	1.2	31	
Gray Yellow Silty CLAY			1.2	29	
		9	1.0	30	
			1.25	30	
	-10	9	1.8	29	
569.9			1.5	29	
Gray with Yellow Silty CLAY			1.25	30	
567.9			1.2	32	
Black Silt LOAM with Gray SHALE				41	
566.9					
End of Hand Auger	-15				
Pocket Penetrometer used for Qu					
"N" values shown are calibrated from a curve converting dynamic cone N to SPT "N". Reference ASTM STP 399					
The blows to set the DCP are not included in the blow count.					
	-20				

The Unconfined Compressive Strength (UCS) Failure Mode is indicated by (B-Bulge, S-Shear, P-Penetrometer)  
The SPT (N value) is the sum of the last two blow values in each sampling zone (AASHTO T206)

BBS, from 137 (Rev. 8-99)

MODEL Path: C:\Sharepoint\ITERS\INCSystems - Midwest - Chicago Construction\DOT\_PFB\_201-041\_DB ITS\12082 - IL 159 Signal & Interconnect\CAD\Sheet Files\0312082\_IL-Route 159\_Soil\_Borings.dgn



USER NAME = bfunk	DESIGNED - BF	REVISED -
	DRAWN - BF	REVISED -
PLOT SCALE = 100,0000' / in.	CHECKED - AD	REVISED -
PLOT DATE = 12/21/2023	DATE - 11/10/23	REVISED -

STATE OF ILLINOIS  
DEPARTMENT OF TRANSPORTATION

SOIL BORING LOGS  
IL ROUTE 159 AND MARKET PLACE / ST. CLAIR SQUARE

SCALE: SHEET OF SHEETS STA. TO STA.

F.A.P. RTE.	SECTION	COUNTY	TOTAL SHEETS	SHEET NO.
600	(130, 130-1, 130-2/TS-3, 82-575)	ST. CLAIR	47	24
CONTRACT NO. 76R78				
ILLINOIS FED. AID PROJECT				

**PROPOSED CONTROLLER SEQUENCE**

SEQUENCE OF OPERATION								
PHASE	1	2	3	4	5	6	7	8
MOVEMENT	NB LT	SB	WB	EB	SB LT	NB	↔	
CONCURRENT MOVEMENT ALLOWED	5 OR 6	5 OR 6	NONE	NONE	1 OR 2	1 OR 2	NOT USED	NOT USED

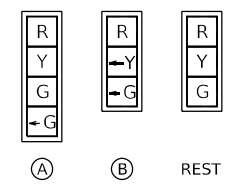
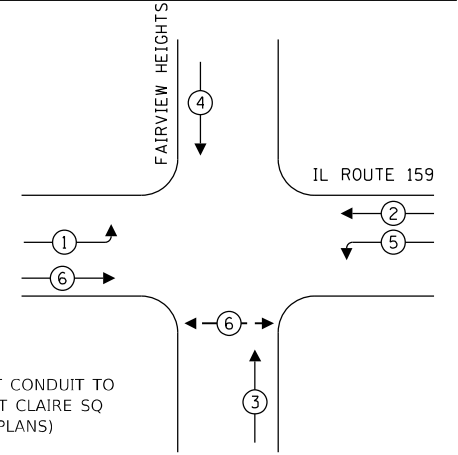
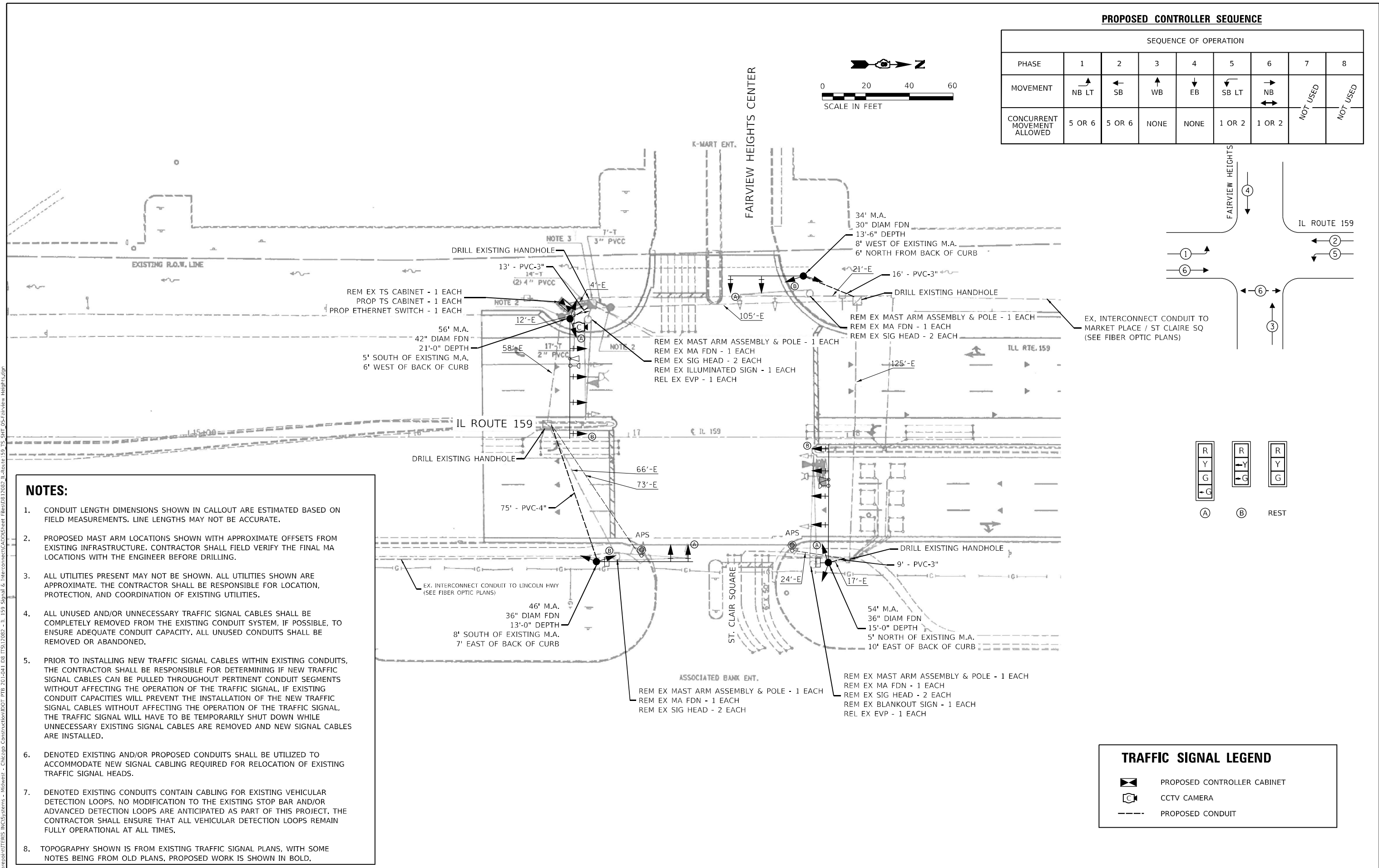
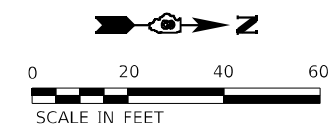

- NOTES:**
- CONDUIT LENGTH DIMENSIONS SHOWN IN CALLOUT ARE ESTIMATED BASED ON FIELD MEASUREMENTS. LINE LENGTHS MAY NOT BE ACCURATE.
  - PROPOSED MAST ARM LOCATIONS SHOWN WITH APPROXIMATE OFFSETS FROM EXISTING INFRASTRUCTURE. CONTRACTOR SHALL FIELD VERIFY THE FINAL MA LOCATIONS WITH THE ENGINEER BEFORE DRILLING.
  - ALL UTILITIES PRESENT MAY NOT BE SHOWN. ALL UTILITIES SHOWN ARE APPROXIMATE. THE CONTRACTOR SHALL BE RESPONSIBLE FOR LOCATION, PROTECTION, AND COORDINATION OF EXISTING UTILITIES.
  - ALL UNUSED AND/OR UNNECESSARY TRAFFIC SIGNAL CABLES SHALL BE COMPLETELY REMOVED FROM THE EXISTING CONDUIT SYSTEM, IF POSSIBLE, TO ENSURE ADEQUATE CONDUIT CAPACITY. ALL UNUSED CONDUITS SHALL BE REMOVED OR ABANDONED.
  - PRIOR TO INSTALLING NEW TRAFFIC SIGNAL CABLES WITHIN EXISTING CONDUITS, THE CONTRACTOR SHALL BE RESPONSIBLE FOR DETERMINING IF NEW TRAFFIC SIGNAL CABLES CAN BE PULLED THROUGHOUT PERTINENT CONDUIT SEGMENTS WITHOUT AFFECTING THE OPERATION OF THE TRAFFIC SIGNAL. IF EXISTING CONDUIT CAPACITIES WILL PREVENT THE INSTALLATION OF THE NEW TRAFFIC SIGNAL CABLES WITHOUT AFFECTING THE OPERATION OF THE TRAFFIC SIGNAL, THE TRAFFIC SIGNAL WILL HAVE TO BE TEMPORARILY SHUT DOWN WHILE UNNECESSARY EXISTING SIGNAL CABLES ARE REMOVED AND NEW SIGNAL CABLES ARE INSTALLED.
  - DENOTED EXISTING AND/OR PROPOSED CONDUITS SHALL BE UTILIZED TO ACCOMMODATE NEW SIGNAL CABLING REQUIRED FOR RELOCATION OF EXISTING TRAFFIC SIGNAL HEADS.
  - DENOTED EXISTING CONDUITS CONTAIN CABLING FOR EXISTING VEHICULAR DETECTION LOOPS. NO MODIFICATION TO THE EXISTING STOP BAR AND/OR ADVANCED DETECTION LOOPS ARE ANTICIPATED AS PART OF THIS PROJECT. THE CONTRACTOR SHALL ENSURE THAT ALL VEHICULAR DETECTION LOOPS REMAIN FULLY OPERATIONAL AT ALL TIMES.
  - TOPOGRAPHY SHOWN IS FROM EXISTING TRAFFIC SIGNAL PLANS, WITH SOME NOTES BEING FROM OLD PLANS. PROPOSED WORK IS SHOWN IN BOLD.

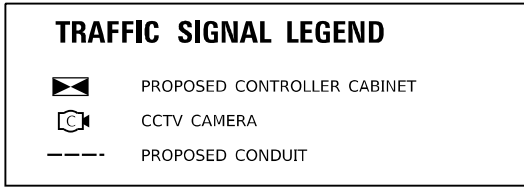

USER NAME = bfunk	DESIGNED - AD	REVISED -
PLOT SCALE = 100,0000' / in.	DRAWN - AD	REVISED -
PLOT DATE = 2/26/2024	CHECKED - BF	REVISED -
	DATE - 2/26/24	REVISED -

**STATE OF ILLINOIS  
DEPARTMENT OF TRANSPORTATION**

**TRAFFIC SIGNAL MODIFICATION PLAN  
IL ROUTE 159 AND FAIRVIEW HEIGHTS CENTER**

SCALE: SHEET OF SHEETS STA. TO STA.

F.A.P. RTE.	SECTION	COUNTY	TOTAL SHEETS	SHEET NO.
600	(130, 130-1, 130-2/75-3, 82-575)	ST. CLAIR	47	25
ILLINOIS FED. AID PROJECT			CONTRACT NO. 76R78	

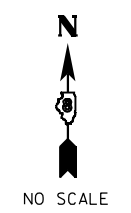

TRAFFIC SIGNAL LEGEND	
	PROP. TRAFFIC SIGNAL CONTROLLER
	PROP. CCTV CAMERA
	PROP. GROUNDING
	PROP. NO. OF CONDUCTORS IN CABLE
	PROP. CCTV CABLE
	PROP. 12" SIGNAL HEAD
	EX. VEHICLE DETECTOR, INDUCTION LOOP
	EX. NO. OF CONDUCTORS IN CABLE
	EX. 12" SIGNAL HEAD
	EX. GROUND MOUNT SERVICE
	EX. GROUNDING
	EX. EMERGENCY VEHICLE PREEMPTION
	EX. CONFIRMATION BEACON

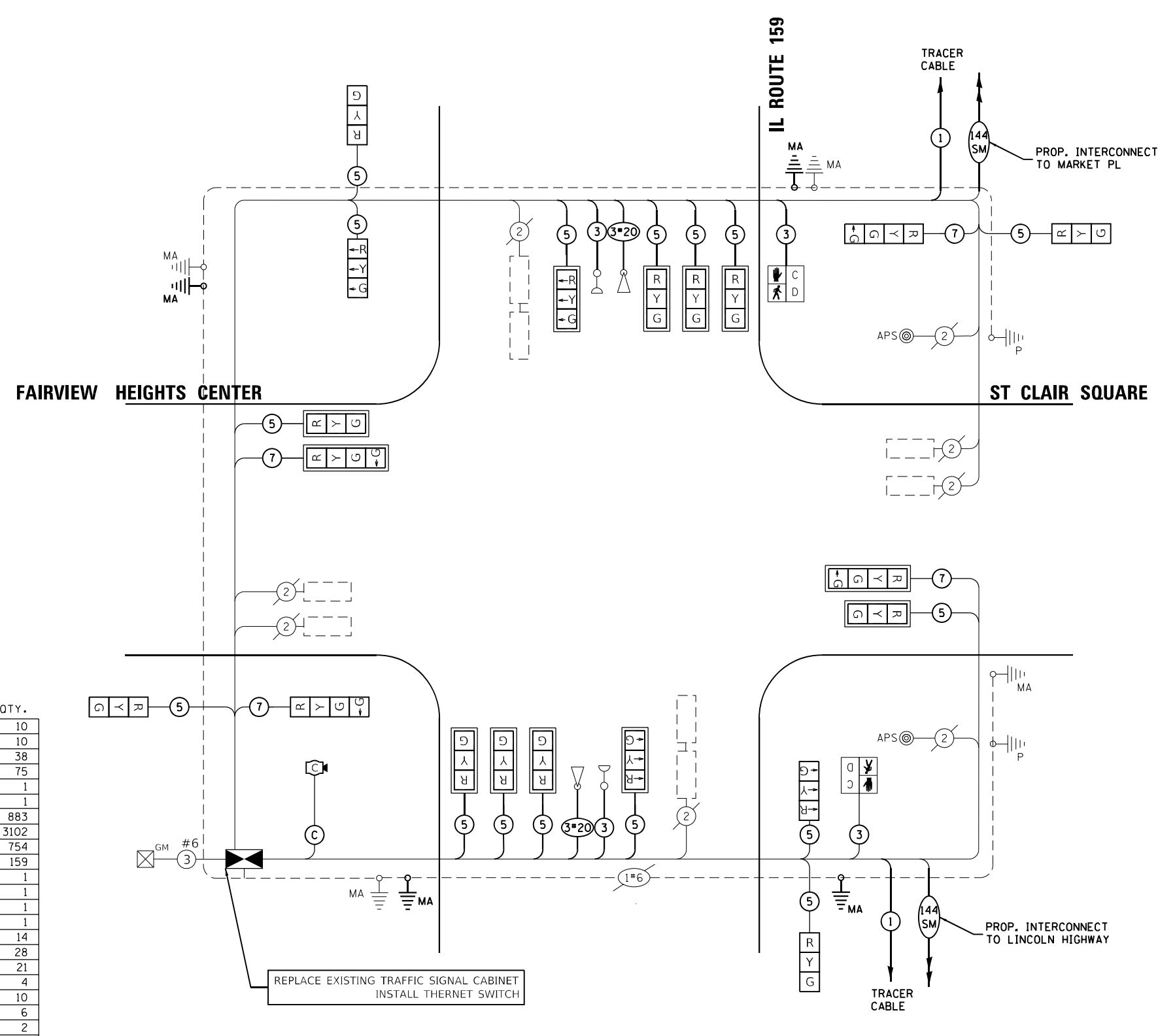

**SCHEDULE OF QUANTITIES**

ITEM DESCRIPTION	UNIT	QTY.
RELOCATE SIGN PANEL - TYPE 1	SQ FT	10
LOCATING UNDERGROUND CABLE	FOOT	10
UNDERGROUND CONDUIT, PVC, 3" DIA.	FOOT	38
UNDERGROUND CONDUIT, PVC, 4" DIA.	FOOT	75
MAINTENANCE OF EXISTING TRAFFIC SIGNAL INSTALLATION	EACH	1
FULL-ACTUATED CONTROLLER AND TYPE IV CABINET	EACH	1
ELECTRIC CABLE IN CONDUIT, SIGNAL NO. 14 3C	FOOT	883
ELECTRIC CABLE IN CONDUIT, SIGNAL NO. 14 5C	FOOT	3102
ELECTRIC CABLE IN CONDUIT, SIGNAL NO. 14 7C	FOOT	754
ELECTRIC CABLE IN CONDUIT, EQUIPMENT GROUNDING CONDUCTOR, NO. 6 1C	FOOT	159
STEEL MAST ARM ASSEMBLY AND POLE, 34 FT.	EACH	1
STEEL MAST ARM ASSEMBLY AND POLE, 46 FT.	EACH	1
STEEL MAST ARM ASSEMBLY AND POLE, 54 FT.	EACH	1
STEEL MAST ARM ASSEMBLY AND POLE, 56 FT.	EACH	1
CONCRETE FOUNDATION, TYPE E 30-INCH DIAMETER	FOOT	14
CONCRETE FOUNDATION, TYPE E 36-INCH DIAMETER	FOOT	28
CONCRETE FOUNDATION, TYPE E 42-INCH DIAMETER	FOOT	21
DRILL EXISTING HANDHOLE	EACH	4
SIGNAL HEAD, LED, 1-FACE, 3-SECTION, MAST-ARM MOUNTED	EACH	10
SIGNAL HEAD, LED, 1-FACE, 3-SECTION, BRACKET MOUNTED	EACH	6
SIGNAL HEAD, LED, 1-FACE, 4-SECTION, BRACKET MOUNTED	EACH	2
SIGNAL HEAD, LED, 1-FACE, 4-SECTION, MAST ARM MOUNTED	EACH	2
TRAFFIC SIGNAL BACKPLATE, RETROREFLECTIVE	EACH	12
RELOCATE EXISTING TRAFFIC SIGNAL EQUIPMENT	EACH	1
* REMOVE ELECTRIC CABLE FROM CONDUIT	FOOT	500
REMOVE EXISTING TRAFFIC SIGNAL EQUIPMENT	EACH	1
REMOVE EXISTING CONCRETE FOUNDATION	EACH	4
EMERGENCY VEHICLE PRIORITY SYSTEM LINE SENSOR CABLE, NO. 20 3/C	FOOT	424
ETHERNET SWITCH	EACH	1
CLOSED CIRCUIT TELEVISION DOME CAMERA, HD	EACH	1

\* NOMINAL QUANTITY TO BE USED AS NEEDED AND AS APPROVED BY ENGINEER

**CABLE PLAN**  
(NOT TO SCALE)

MODEL: Default  
 FILE NAME: C:\Sharepoint\ITERIS - Midwest - Chicago Construction\DOT\_PBE\_201-041\_D8 ITS\12082 - IL 159 Signal & Interconnect\CADD\Sheet Files\0312082\_IL-Route 159\_Cable\_SHT\_05-Fairview\_Heights.dgn



USER NAME = bfunk	DESIGNED - AD	REVISED -
PLOT SCALE = 100,0000' / in.	DRAWN - AD	REVISED -
PLOT DATE = 2/26/2024	CHECKED - BF	REVISED -
	DATE - 2/26/24	REVISED -

**STATE OF ILLINOIS**  
**DEPARTMENT OF TRANSPORTATION**

**TRAFFIC SIGNAL CABLE PLAN**  
**IL ROUTE 159 AND FAIRVIEW HEIGHTS CENTER**

F.A.P. RTE.	SECTION	COUNTY	TOTAL SHEETS	SHEET NO.
600	(130, 130-1, 130-2)TS-3, 82-575	ST. CLAIR	47	26
CONTRACT NO. 76R78				
ILLINOIS FED. AID PROJECT				

SCALE: SHEET OF SHEETS STA. TO STA.





MODEL: Default  
 FILE NAME: C:\Sharepoint\ITERIS - INC\Systems - Midwest - Chicago Construction\DOT - PB, 201-041 DB ITS\12082 - IL 159 Signal & Interconnect\CADD\Sheet Files\0812082\_IL\_Route 159\_TS\_SHT\_06-Lincoln Hwy-Lincoln Trail.dgn

**SOUTHWEST CORNER**

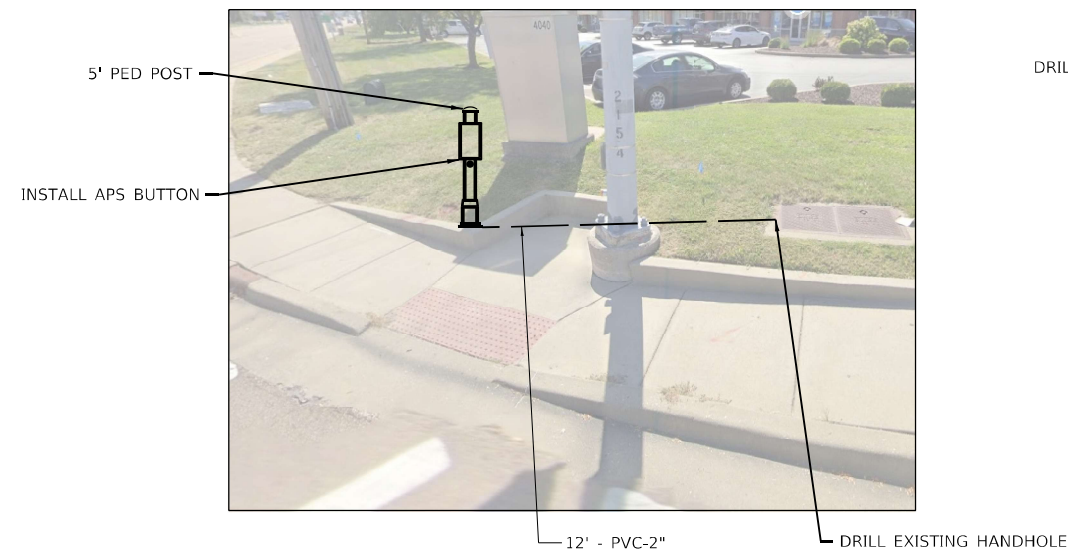

**SOUTHEAST CORNER**

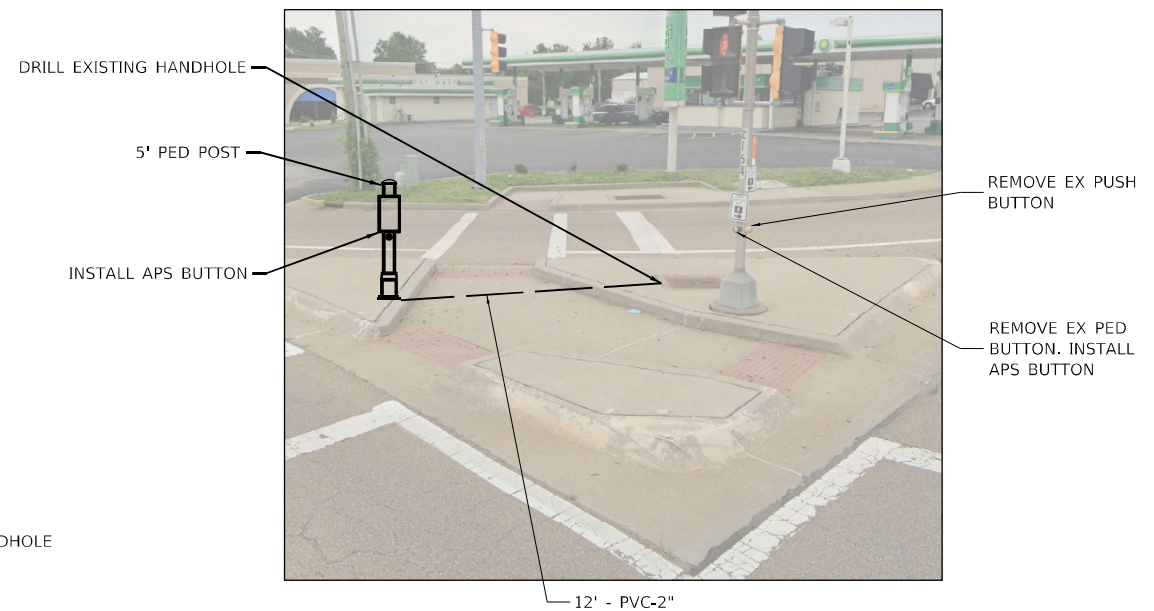

**NOTES:**

1. PEDESTRIAN PUSH BUTTON POSTS TO BE FIELD-LOCATED IN COORDINATION WITH THE ENGINEER.



USER NAME = bfunk	DESIGNED - AD	REVISED -
	DRAWN - AD	REVISED -
PLOT SCALE = 100,0000' / in.	CHECKED - BF	REVISED -
PLOT DATE = 7/22/2025	DATE - 2/26/24	REVISED -

**STATE OF ILLINOIS  
DEPARTMENT OF TRANSPORTATION**

**TRAFFIC SIGNAL MODIFICATION PLAN  
IL ROUTE 159 AND LINCOLN HWY / LINCOLN TRAIL**

SCALE: SHEET OF SHEETS STA. TO STA.

F.A.P. RTE.	SECTION	COUNTY	TOTAL SHEETS	SHEET NO.
600	(130, 130-1, 130-2)TS-3, 82-5T5	ST. CLAIR	47	29
CONTRACT NO. 76R78				
ILLINOIS		FED. AID PROJECT		









MODEL: Default  
 FILE NAME: C:\Sharepoint\ITERIS - INC\Systems - Midwest - Chicago Construction\DOT - PFB, 201-041, DB IT512082 - IL 159 Signal & Interconnect\CADD\Sheet Files\0812082\_IL\_Route 159\_TS\_SHT\_071 Lincoln\_PL Shopping\_Ctr.dgn

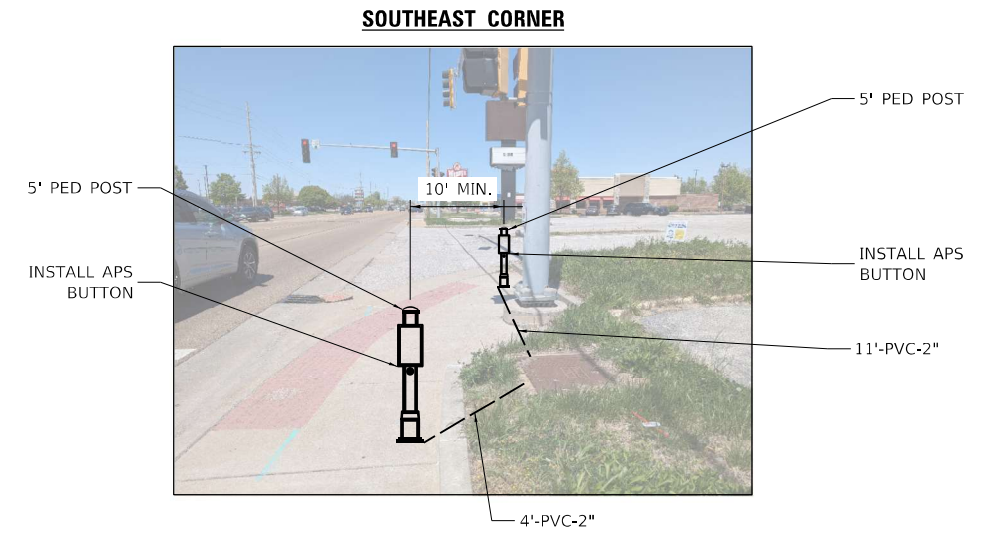
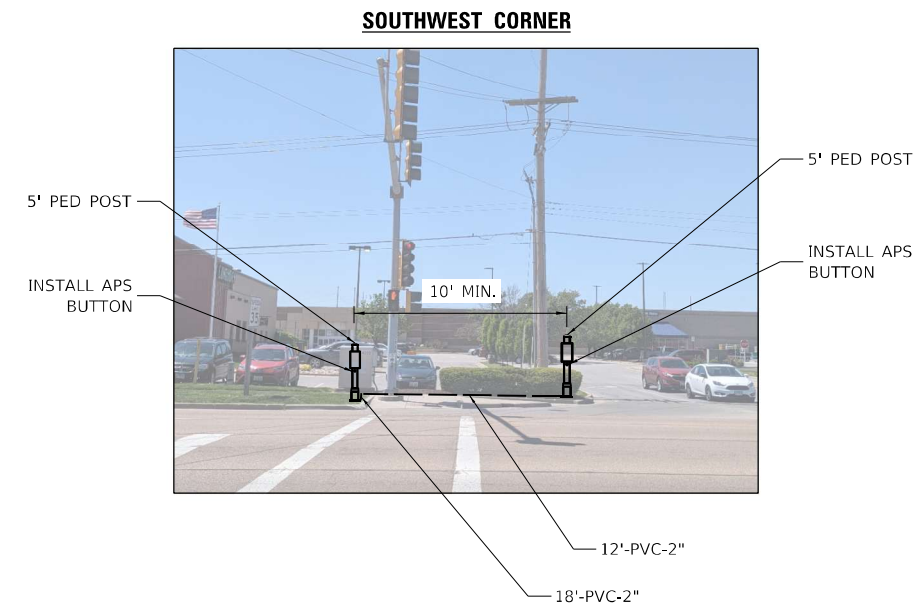
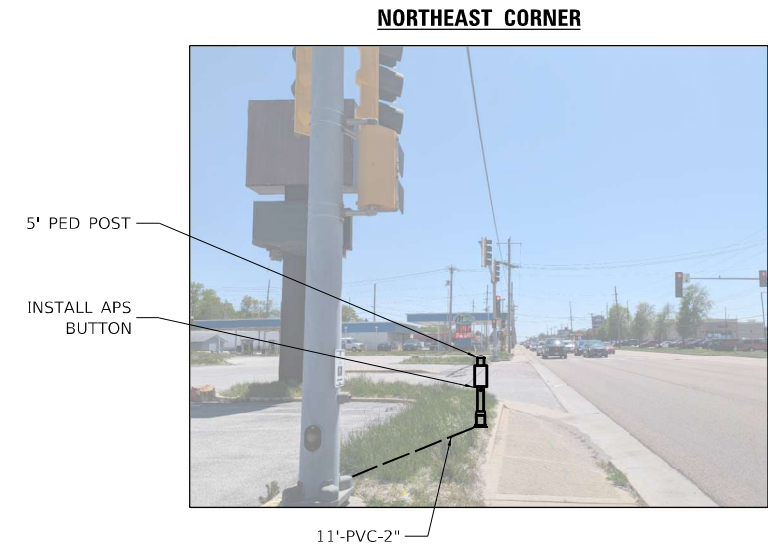
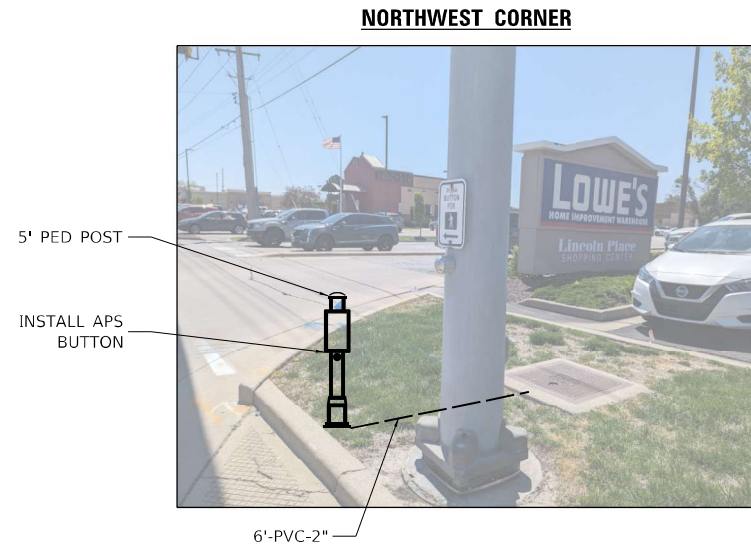

**NOTES:**

1. PEDESTRIAN PUSH BUTTON POSTS TO BE FIELD-LOCATED IN COORDINATION WITH THE ENGINEER.



USER NAME = bfunk	DESIGNED - AD	REVISED -
	DRAWN - AD	REVISED -
PLOT SCALE = 100,0000 ' / in.	CHECKED - BF	REVISED -
PLOT DATE = 2/26/2024	DATE - 2/26/24	REVISED -

**STATE OF ILLINOIS  
 DEPARTMENT OF TRANSPORTATION**

**TRAFFIC SIGNAL MODIFICATION PLAN  
 IL ROUTE 159 AND LINCOLN PL SHOPPING CTR**

SCALE: SHEET OF SHEETS STA. TO STA.

F.A.P. RTE.	SECTION	COUNTY	TOTAL SHEETS	SHEET NO.
600	(130, 130-1, 130-2)TS-3, 82-575	ST. CLAIR	47	34
CONTRACT NO. 76R78				
ILLINOIS FED. AID PROJECT				

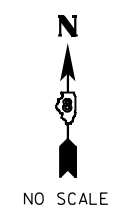

TRAFFIC SIGNAL LEGEND	
	PROP. TRAFFIC SIGNAL CONTROLLER
	PROP. CCTV CAMERA
	PROP. GROUNDING
	PROP. NO. OF CONDUCTORS IN CABLE
	PROP. CCTV CABLE
	PROP. 12" SIGNAL HEAD
	EX. VEHICLE DETECTOR, INDUCTION LOOP
	EX. NO. OF CONDUCTORS IN CABLE
	EX. 12" SIGNAL HEAD
	EX. GROUND MOUNT SERVICE
	EX. GROUNDING
	EX. EMERGENCY VEHICLE PREEMPTION
	EX. CONFIRMATION BEACON

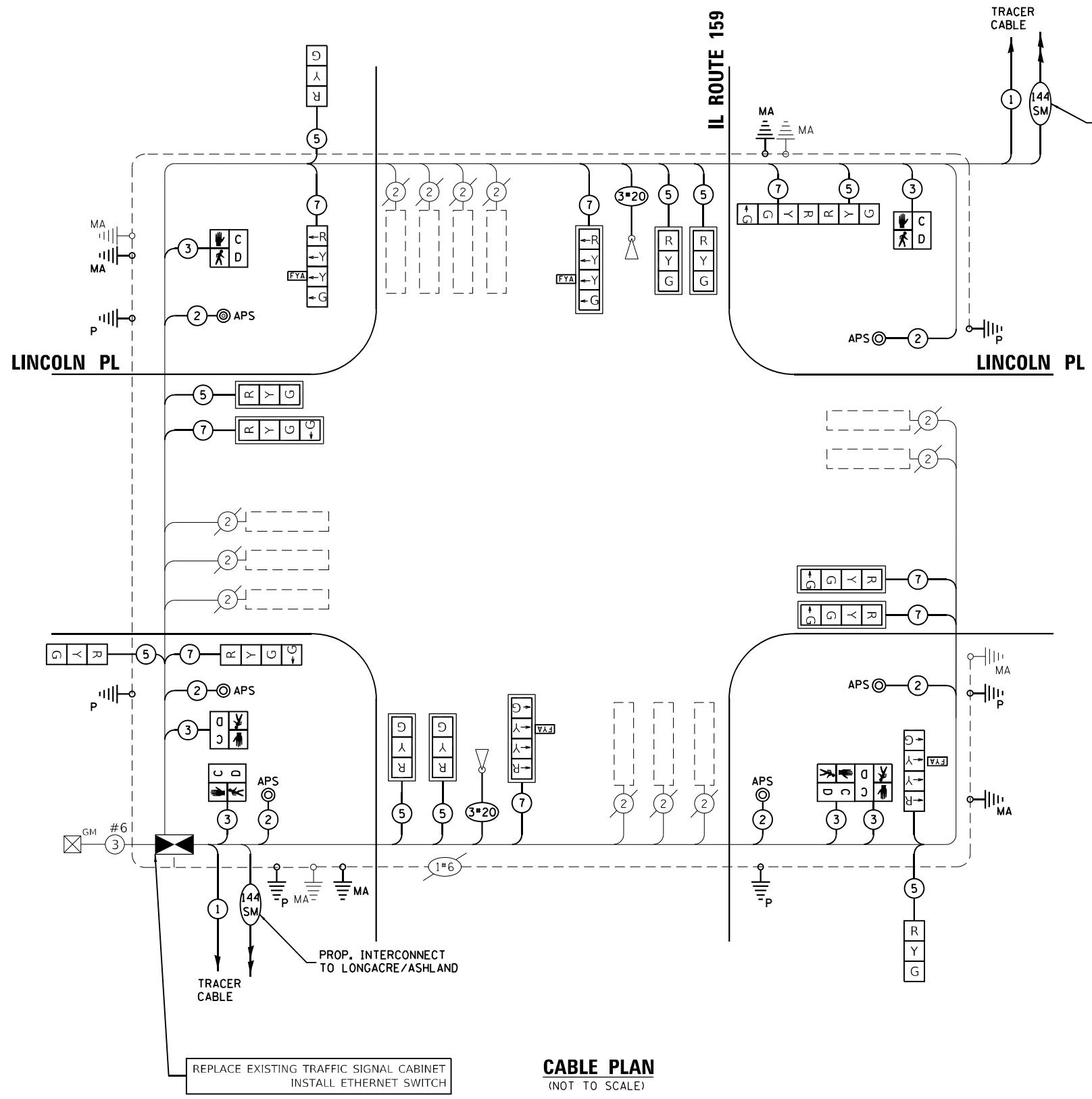

**SCHEDULE OF QUANTITIES**

ITEM DESCRIPTION	UNIT	QTY.
SIGN PANEL - TYPE 1	SO FT	30
RELOCATE SIGN PANEL - TYPE 1	SO FT	17
LOCATING UNDERGROUND CABLE	FOOT	10
UNDERGROUND CONDUIT, PVC, 2" DIA.	FOOT	69
UNDERGROUND CONDUIT, PVC, 3" DIA.	FOOT	64
MAINTENANCE OF EXISTING TRAFFIC SIGNAL INSTALLATION	EACH	1
FULL-ACTUATED CONTROLLER AND TYPE IV CABINET	EACH	1
ELECTRIC CABLE IN CONDUIT, SIGNAL NO. 14 2C	FOOT	737
ELECTRIC CABLE IN CONDUIT, SIGNAL NO. 14 3C	FOOT	789
ELECTRIC CABLE IN CONDUIT, SIGNAL NO. 14 5C	FOOT	1548
ELECTRIC CABLE IN CONDUIT, SIGNAL NO. 14 7C	FOOT	1617
ELECTRIC CABLE IN CONDUIT, EQUIPMENT GROUNDING CONDUCTOR, NO. 6 1C	FOOT	248
STEEL MAST ARM ASSEMBLY AND POLE, 38 FT.	EACH	1
STEEL MAST ARM ASSEMBLY AND POLE, 46 FT.	EACH	3
CONCRETE FOUNDATION, TYPE E 30-INCH DIAMETER	FOOT	14
CONCRETE FOUNDATION, TYPE E 36-INCH DIAMETER	FOOT	39
DRILL EXISTING HANDHOLE	EACH	10
SIGNAL HEAD, LED, 1-FACE, 3-SECTION, MAST-ARM MOUNTED	EACH	5
SIGNAL HEAD, LED, 1-FACE, 3-SECTION, BRACKET MOUNTED	EACH	4
SIGNAL HEAD, LED, 1-FACE, 4-SECTION, BRACKET MOUNTED	EACH	4
SIGNAL HEAD, LED, 1-FACE, 4-SECTION, MAST ARM MOUNTED	EACH	5
PEDESTRIAN SIGNAL HEAD, LED, 1-FACE, BRACKET MOUNTED WITH COUNTDOWN TIMER	EACH	2
PEDESTRIAN SIGNAL HEAD, LED, 2-FACE, BRACKET MOUNTED WITH COUNTDOWN TIMER	EACH	2
TRAFFIC SIGNAL BACKPLATE, RETROREFLECTIVE	EACH	10
RELOCATE EXISTING TRAFFIC SIGNAL EQUIPMENT	EACH	1
* REMOVE ELECTRIC CABLE FROM CONDUIT	FOOT	500
REMOVE EXISTING TRAFFIC SIGNAL EQUIPMENT	EACH	1
REMOVE EXISTING CONCRETE FOUNDATION	EACH	4
EMERGENCY VEHICLE PRIORITY SYSTEM LINE SENSOR CABLE, NO. 20 3/C	FOOT	364
ETHERNET SWITCH	EACH	1
ACCESSIBLE PEDESTRIAN SIGNALS	EACH	6
PEDESTRIAN PUSH-BUTTON POST	EACH	6
CONCRETE FOUNDATION, TYPE A 12-INCH DIAMETER	FOOT	24

\* NOMINAL QUANTITY TO BE USED AS NEEDED AND AS APPROVED BY ENGINEER

**CABLE PLAN**  
(NOT TO SCALE)

MODEL: D:\p\h\iteris\share\projects\iteris\inc\systems - midwest - chicgo construction\DOT\_PFB\_201-041\_D8\_ITS12082 - IL\_159\_Signal & Interconnect\CADD\Sheet Files\IL159\_Cable\_SHT\_074.lincoln\_pl\_shopping\_ctr.dgn  
 FILE NAME: C:\share\projects\iteris\inc\systems - midwest - chicgo construction\DOT\_PFB\_201-041\_D8\_ITS12082 - IL\_159\_Signal & Interconnect\CADD\Sheet Files\IL159\_Cable\_SHT\_074.lincoln\_pl\_shopping\_ctr.dgn



USER NAME = bfunck	DESIGNED - AD	REVISED -
PLOT SCALE = 100,0000' / in.	DRAWN - AD	REVISED -
PLOT DATE = 2/26/2024	CHECKED - BF	REVISED -
	DATE - 2/26/24	REVISED -

**STATE OF ILLINOIS**  
**DEPARTMENT OF TRANSPORTATION**

**TRAFFIC SIGNAL CABLE PLAN**  
**IL ROUTE 159 AND LINCOLN PL SHOPPING CTR**

F.A.P. RTE.	SECTION	COUNTY	TOTAL SHEETS	SHEET NO.
600	(130, 130-1, 130-2/TS-3, 82-575)	ST. CLAIR	47	35
CONTRACT NO. 76R78				
ILLINOIS FED. AID PROJECT				

SCALE: SHEET OF SHEETS STA. TO STA.



# SOIL BORING LOG

ROUTE FAP 600 (IL 159) DESCRIPTION IL 159 & Lincoln Place LOGGED BY KEG - MTH  
 SECTION (130, 130-1, 130-2)TS-3 LOCATION SEC. TWP. RNG. 3 PM  
 COUNTY St. Clair DRILLING METHOD HSA HAMMER TYPE Auto

STRUCT. NO.	D	B	U	M	Surface Water Elev.
Station	E	L	C	O	Stream Bed Elev.
BORING NO.	P	O	S	I	Groundwater Elev.:
Station	T	W	Qu	S	First Encounter
Offset	H	S		T	Upon Completion
Ground Surface Elev. ft	(ft)	(/6")	(tsf)	(%)	After Hrs.
8.5" Asphalt	99.3				n/a ft
Dark Brown Silty Clay		1			
		4	2.25	23	
		3	P		
Becomes Grayish Brown	96.0				
		WH			
		1	2.5	28	
		2	P		
		WH			
		1	0.83	29	
		2	B		
		1			
		2	2	27	
		3	P		
Dark Brown Clayey Silt	89.0				
		WH			
		WH	2	66	
		WH	P		
becomes wet	87.0				
		2			
		2	2	57	
		3	P		
End of Boring	85.0				

The Unconfined Compressive Strength (UCS) Failure Mode is indicated by (B-Bulge, S-Shear, P-Penetrometer)  
 The SPT (N value) is the sum of the last two blow values in each sampling zone (AASHTO T206)

BBS, from 137 (Rev. 8-99)



# SOIL BORING LOG

ROUTE FAP 600 (IL 159) DESCRIPTION IL 159 & Lincoln Place LOGGED BY KEG - MTH  
 SECTION (130, 130-1, 130-2)TS-3 LOCATION SEC. TWP. RNG. 3 PM  
 COUNTY St. Clair DRILLING METHOD HSA HAMMER TYPE Auto

STRUCT. NO.	D	B	U	M	Surface Water Elev.
Station	E	L	C	O	Stream Bed Elev.
BORING NO.	P	O	S	I	Groundwater Elev.:
Station	T	W	Qu	S	First Encounter
Offset	H	S		T	Upon Completion
Ground Surface Elev. ft	(ft)	(/6")	(tsf)	(%)	After Hrs.
5" Asphalt	99.6				n/a ft
Grayish brown Silty Clay		2			
		2	2.25	25	
		4	P		
becomes very soft	96.0				
		1			
		1	1.25	28	
		2	P		
		WH			
		2	0.44	27	
		2	B		
		2			
		2	0.57	27	
		3	B		
Dark Brown Clayey Silt w/ organics	89.0				
		1			
		2	1.75	68	
		3	P		
becomes wet	86.5				
		2			
		3	1	59	
		4	P		
End of Boring	85.0				

The Unconfined Compressive Strength (UCS) Failure Mode is indicated by (B-Bulge, S-Shear, P-Penetrometer)  
 The SPT (N value) is the sum of the last two blow values in each sampling zone (AASHTO T206)

BBS, from 137 (Rev. 8-99)

MODEL: Default  
 FILE NAME: C:\Sharepoint\ITERS - INC\Systems - Midwest - Chicago Construction\DOT - ITR - IL 159 Signal & Interconnect\CADD\Sheet Files\0912082 - IL Route 159 Soil Borings.dgn  
 MODEL: Default  
 FILE NAME: C:\Sharepoint\ITERS - INC\Systems - Midwest - Chicago Construction\DOT - ITR - IL 159 Signal & Interconnect\CADD\Sheet Files\0912082 - IL Route 159 Soil Borings.dgn



USER NAME = bfunk	DESIGNED - BF	REVISED -
	DRAWN - BF	REVISED -
PLOT SCALE = 100,0000' / in.	CHECKED - AD	REVISED -
PLOT DATE = 12/21/2023	DATE - 11/10/23	REVISED -

STATE OF ILLINOIS  
 DEPARTMENT OF TRANSPORTATION

SOIL BORING LOGS  
 IL ROUTE 159 AND LINCOLN PL SHOPPING CTR

SCALE: SHEET OF SHEETS STA. TO STA.

F.A.P. RTE.	SECTION	COUNTY	TOTAL SHEETS	SHEET NO.
600	(130, 130-1, 130-2)TS-3, 82-575	ST. CLAIR	47	36
CONTRACT NO. 76R78			ILLINOIS FED. AID PROJECT	

# SOIL BORING LOG

ROUTE FAP 600 (IL 159) DESCRIPTION IL 159 & Lincoln Place LOGGED BY KEG - MTH  
 SECTION (130, 130-1, 130-2)TS-3 LOCATION SEC. TWP. RNG. 3 PM  
 COUNTY St. Clair DRILLING METHOD HSA HAMMER TYPE Auto

STRUCT. NO.	D	B	U	M	Surface Water Elev.
Station	E	L	C	O	Stream Bed Elev.
BORING NO.	P	O	S	I	Groundwater Elev.:
Station	T	W	Qu	S	First Encounter
Offset	H	S		T	Upon Completion
Ground Surface Elev. ft	(ft)	(/6")	(tsf)	(%)	After Hrs.
3" Asphalt	99.8				n/a ft
12" Concrete	98.8	4			ft
Brown & Gray Silty Clay		2	3.25	23	
		6	P		
	97.0				
Brown & Gray very soft Clayey Silt		1			
		1	0.04	28	
		1	B		
		1			
		1	0.13	29	
		2	B		
	91.0	WH			
becomes moist		1	0.09	29	
		2	B		
	89.0				
Brown Clayey Silt w/ organics		1			
		1	1	63	
		3	P		
		1			
		1	1.75	70	
		3	P		
	85.0				
End of Boring					

The Unconfined Compressive Strength (UCS) Failure Mode is indicated by (B-Bulge, S-Shear, P-Penetrometer)  
 The SPT (N value) is the sum of the last two blow values in each sampling zone (AASHTO T206)

BBS, from 137 (Rev. 8-99)

# SOIL BORING LOG

ROUTE FAP 600 (IL 159) DESCRIPTION IL 159 & Lincoln Place LOGGED BY KEG - MTH  
 SECTION (130, 130-1, 130-2)TS-3 LOCATION SEC. TWP. RNG. 3 PM  
 COUNTY St. Clair DRILLING METHOD HSA HAMMER TYPE Auto

STRUCT. NO.	D	B	U	M	Surface Water Elev.
Station	E	L	C	O	Stream Bed Elev.
BORING NO.	P	W	S	I	Groundwater Elev.:
Station	T	S	Qu	T	First Encounter
Offset	H	S		T	Upon Completion
Ground Surface Elev. ft	(ft)	(/6")	(tsf)	(%)	After Hrs.
10" Concrete	99.2				n/a ft
6" gravel agg base	98.7	3			ft
Brown well sorted coarse Sand		10	-	7	
Med dense		7	-		
		2			
		2	-	10	
		1	-		
	94.0	WH			
Poor Recovery		WH	-	14	
Fine grained Brown Silty Sand		WH	-		
Med dense					
	91.5	WH			
gray very soft Clayey Silt		WH	0.13	30	
		1	B		
	89.0				
Brown soft Clayey Silt		2	2.01	53	
becomes wet		3	S		
w/ organics		1			
		1	1.75	53	
		3	P		
	85.0				
End of Boring					

The Unconfined Compressive Strength (UCS) Failure Mode is indicated by (B-Bulge, S-Shear, P-Penetrometer)  
 The SPT (N value) is the sum of the last two blow values in each sampling zone (AASHTO T206)

BBS, from 137 (Rev. 8-99)

MODEL: Default  
 FILE NAME: C:\Sharepoint\ITERS - INC\Systems - Midwest - Chicago Construction\DOT\_PFB\_201-041\_D8 ITS\12082 - IL 159 Signal & Interconnect\CADD\Sheet Files\0912082\_IL-Route 159\_Soil\_Borings.dgn



USER NAME = bfunk	DESIGNED - BF	REVISED -
	DRAWN - BF	REVISED -
PLOT SCALE = 100,0000' / in.	CHECKED - AD	REVISED -
PLOT DATE = 12/21/2023	DATE - 11/10/23	REVISED -

STATE OF ILLINOIS  
DEPARTMENT OF TRANSPORTATION

SOIL BORING LOGS  
IL ROUTE 159 AND LINCOLN PL SHOPPING CTR

SCALE: SHEET OF SHEETS STA. TO STA.

F.A.P. RTE.	SECTION	COUNTY	TOTAL SHEETS	SHEET NO.
600	(130, 130-1, 130-2)TS-3, 82-575	ST. CLAIR	47	37
CONTRACT NO. 76R78			ILLINOIS FED. AID PROJECT	

**PROPOSED CONTROLLER SEQUENCE**

SEQUENCE OF OPERATION								
PHASE	1	2	3	4	5	6	7	8
MOVEMENT	NB LT	SB	WB LT	EB	SB LT	SB	EB LT	WB
CONCURRENT MOVEMENT ALLOWED	5 OR 6	5 OR 6	7 OR 8	7 OR 8	1 OE 2	1 OR 2	3 OR 4	3 OR 4

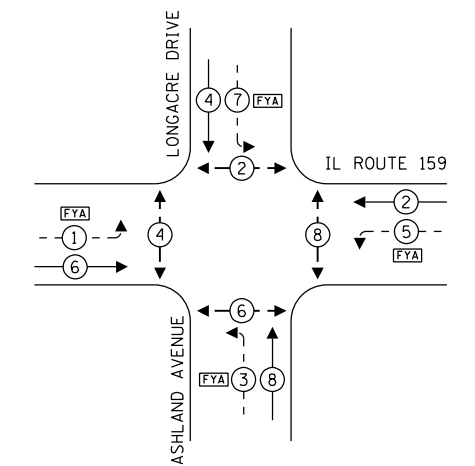
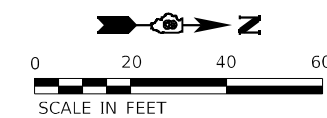
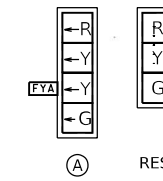

**NOTES:**

- CONDUIT LENGTH DIMENSIONS SHOWN IN CALLOUT ARE ESTIMATED BASED ON FIELD MEASUREMENTS. LINE LENGTHS MAY NOT BE ACCURATE.
- PROPOSED MAST ARM LOCATIONS SHOWN WITH APPROXIMATE OFFSETS FROM EXISTING INFRASTRUCTURE. CONTRACTOR SHALL FIELD VERIFY THE FINAL MA LOCATIONS WITH THE ENGINEER BEFORE DRILLING.
- ALL UTILITIES PRESENT MAY NOT BE SHOWN. ALL UTILITIES SHOWN ARE APPROXIMATE. THE CONTRACTOR SHALL BE RESPONSIBLE FOR LOCATION, PROTECTION, AND COORDINATION OF EXISTING UTILITIES.
- ALL UNUSED AND/OR UNNECESSARY TRAFFIC SIGNAL CABLES SHALL BE COMPLETELY REMOVED FROM THE EXISTING CONDUIT SYSTEM, IF POSSIBLE, TO ENSURE ADEQUATE CONDUIT CAPACITY. ALL UNUSED CONDUITS SHALL BE REMOVED OR ABANDONED.
- PRIOR TO INSTALLING NEW TRAFFIC SIGNAL CABLES WITHIN EXISTING CONDUITS, THE CONTRACTOR SHALL BE RESPONSIBLE FOR DETERMINING IF NEW TRAFFIC SIGNAL CABLES CAN BE PULLED THROUGHOUT PERTINENT CONDUIT SEGMENTS WITHOUT AFFECTING THE OPERATION OF THE TRAFFIC SIGNAL. IF EXISTING CONDUIT CAPACITIES WILL PREVENT THE INSTALLATION OF THE NEW TRAFFIC SIGNAL CABLES WITHOUT AFFECTING THE OPERATION OF THE TRAFFIC SIGNAL, THE TRAFFIC SIGNAL WILL HAVE TO BE TEMPORARILY SHUT DOWN WHILE UNNECESSARY EXISTING SIGNAL CABLES ARE REMOVED AND NEW SIGNAL CABLES ARE INSTALLED.
- DENOTED EXISTING AND/OR PROPOSED CONDUITS SHALL BE UTILIZED TO ACCOMMODATE NEW SIGNAL CABLING REQUIRED FOR RELOCATION OF EXISTING TRAFFIC SIGNAL HEADS.
- DENOTED EXISTING CONDUITS CONTAIN CABLING FOR EXISTING VEHICULAR DETECTION LOOPS. NO MODIFICATION TO THE EXISTING STOP BAR AND/OR ADVANCED DETECTION LOOPS ARE ANTICIPATED AS PART OF THIS PROJECT. THE CONTRACTOR SHALL ENSURE THAT ALL VEHICULAR DETECTION LOOPS REMAIN FULLY OPERATIONAL AT ALL TIMES.
- TOPOGRAPHY SHOWN IS FROM EXISTING TRAFFIC SIGNAL PLANS, WITH SOME NOTES BEING FROM OLD PLANS. PROPOSED WORK IS SHOWN IN BOLD.
- CONTRACTOR SHALL COORDINATE WITH THE ENGINEER AND THE CONTRACTOR RESPONSIBLE FOR IDOT PROJECT 97808 ALONG FAU 9163, LONGACRE DRIVE, SECTION 20-0004-00-RS, ST. CLAIR COUNTY, STATE JOB C-98-013-24.

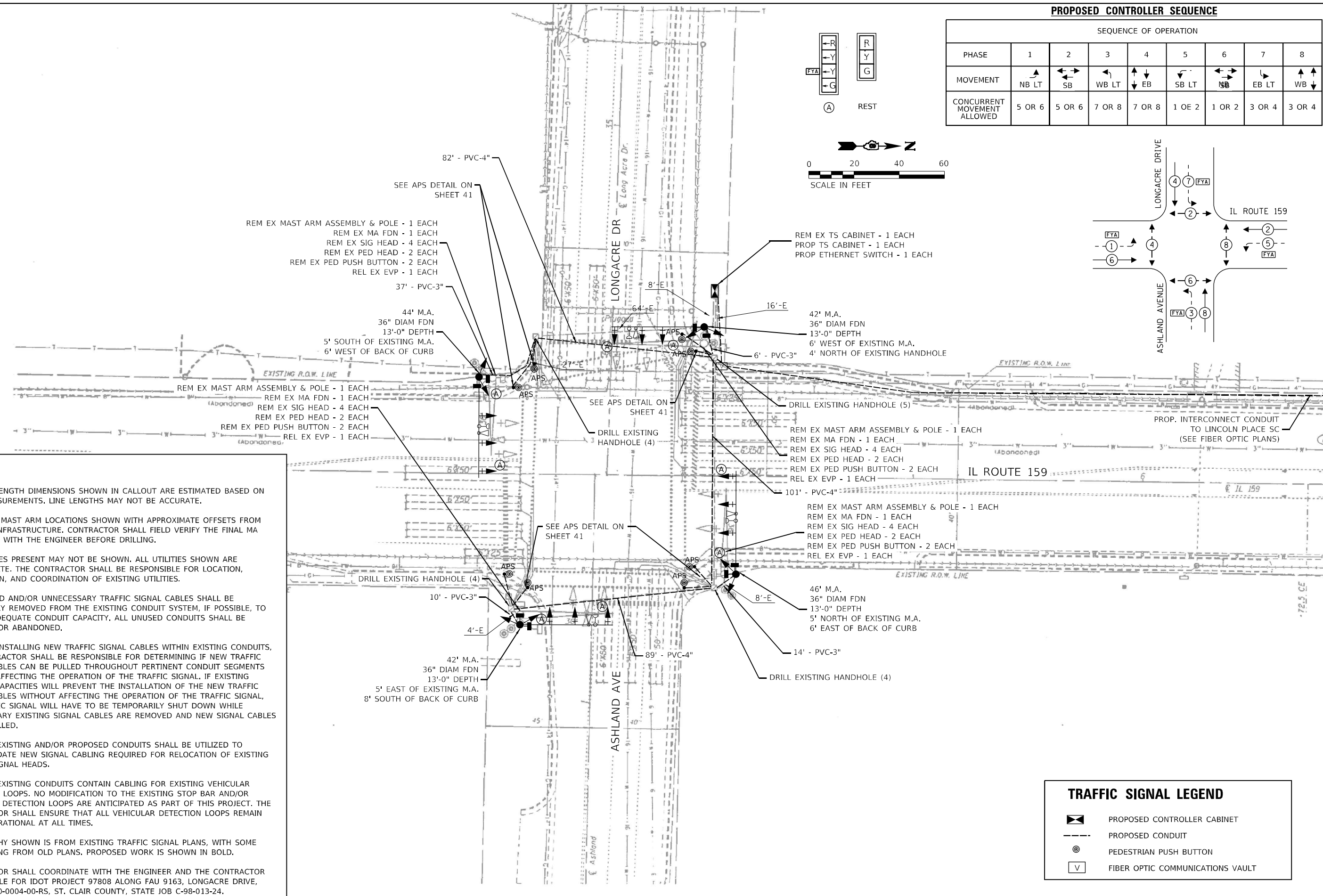

**TRAFFIC SIGNAL LEGEND**

	PROPOSED CONTROLLER CABINET
	PROPOSED CONDUIT
	PEDESTRIAN PUSH BUTTON
	FIBER OPTIC COMMUNICATIONS VAULT

MODEL: Default  
 FILE NAME: C:\Sharepoint\ITERIS, INC\Systems - Midwest - Chicago Construction\IDOT\_PFB\_201-041\_D8 ITS\12082 - IL 159 Signal & Interconnect\CADD\Sheet Files\0812082\_IL\_Route 159\_TS\_SHT\_08-Longacre-Ashland.dwg  
 MODEL: Default  
 FILE NAME: C:\Sharepoint\ITERIS, INC\Systems - Midwest - Chicago Construction\IDOT\_PFB\_201-041\_D8 ITS\12082 - IL 159 Signal & Interconnect\CADD\Sheet Files\0812082\_IL\_Route 159\_TS\_SHT\_08-Longacre-Ashland.dwg



USER NAME = bfunck	DESIGNED - AD	REVISED -
	DRAWN - AD	REVISED -
PLOT SCALE = 100,0000' / in.	CHECKED - BF	REVISED -
PLOT DATE = 3/22/2024	DATE - 2/26/24	REVISED -

**STATE OF ILLINOIS  
DEPARTMENT OF TRANSPORTATION**

**TRAFFIC SIGNAL MODIFICATION PLAN**  
**IL ROUTE 159 AND LONGACRE DRIVE / ASHLAND AVENUE**

SCALE: SHEET OF SHEETS STA. TO STA.

F.A.P. RTE.	SECTION	COUNTY	TOTAL SHEETS	SHEET NO.
600	(130, 130-1, 130-2)TS-3, 82-575	ST. CLAIR	47	38
CONTRACT NO. 76R78				
ILLINOIS FED. AID PROJECT				

MODEL Path: \\...  
 FILE NAME: C:\Sharepoint\ITERIS - INC\Systems - Midwest - Chicago Construction\DOT\_PFB\_201-041\_DB ITS\12082 - IL 159 Signal & Interconnect\CADD\Sheet Files\0817082\_IL\_Route 159 ITS\_SHT\_081-contract-re-ashland.dwg

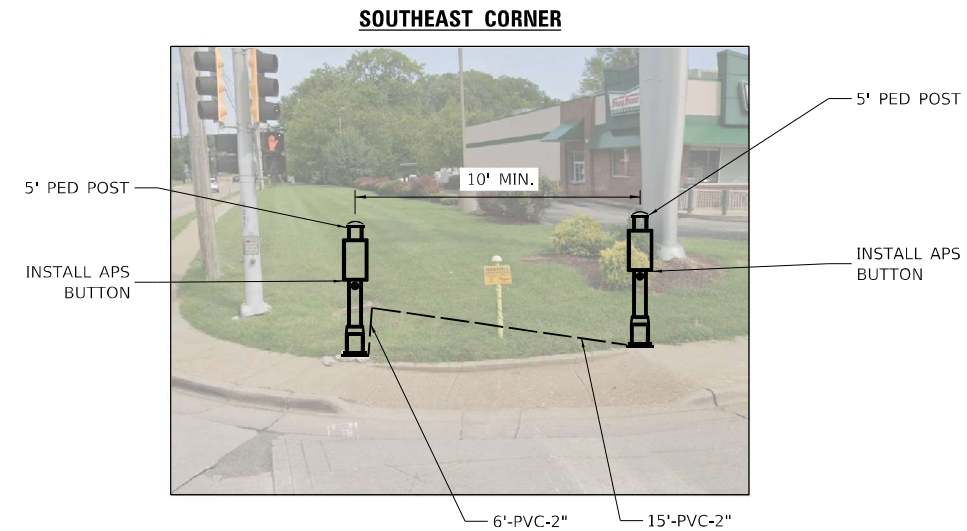
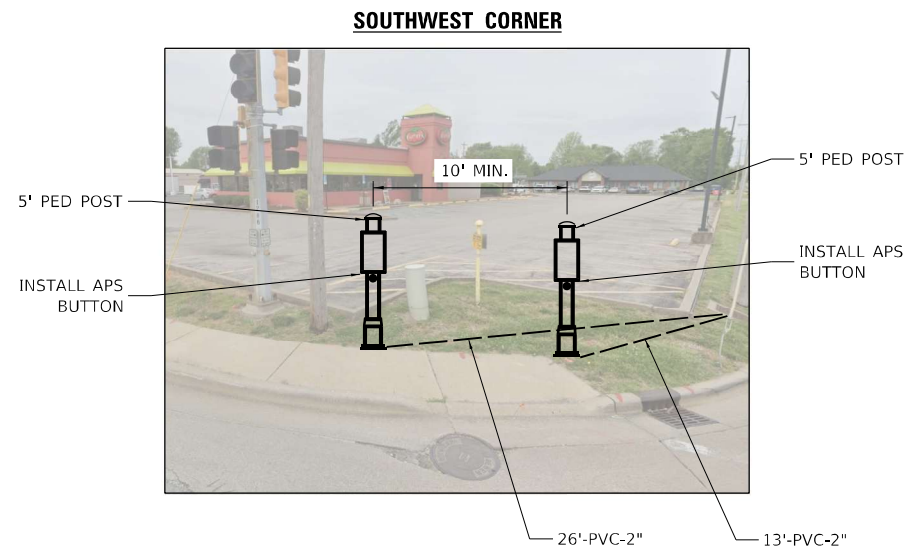
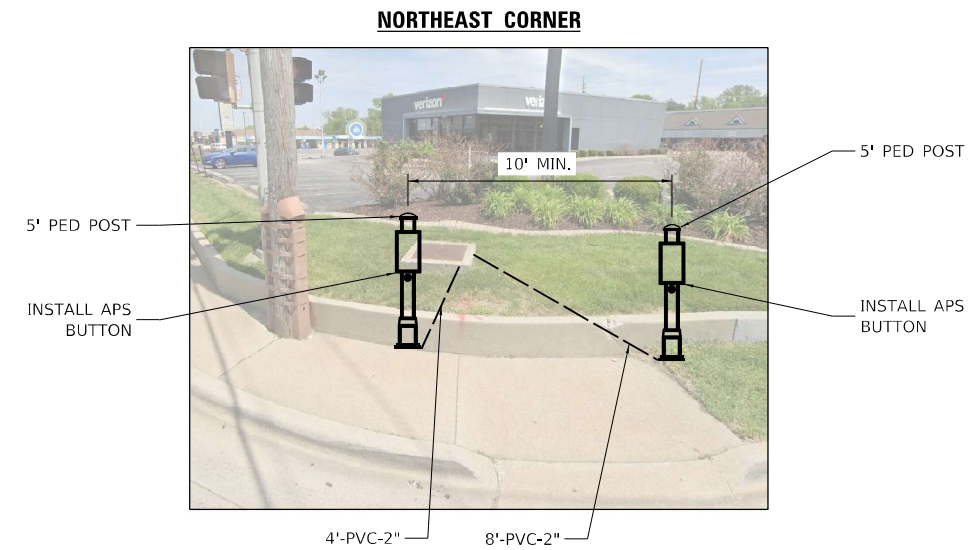
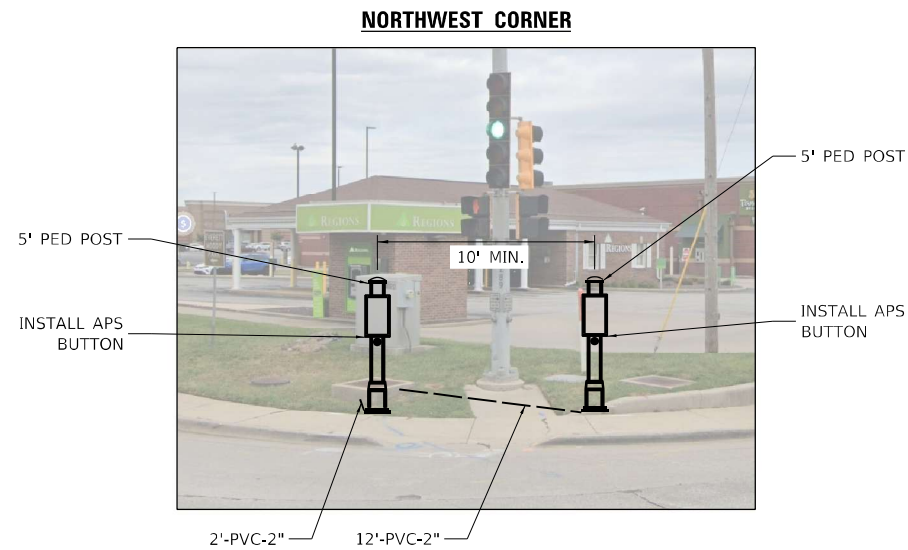

**NOTES:**

1. PEDESTRIAN PUSH BUTTON POSTS TO BE FIELD-LOCATED IN COORDINATION WITH THE ENGINEER.



USER NAME = bfunk	DESIGNED - AD	REVISED -
	DRAWN - AD	REVISED -
PLOT SCALE = 100,0000' / in.	CHECKED - BF	REVISED -
PLOT DATE = 2/26/2024	DATE - 2/26/24	REVISED -

**STATE OF ILLINOIS  
DEPARTMENT OF TRANSPORTATION**

**TRAFFIC SIGNAL MODIFICATION PLAN  
IL ROUTE 159 AND LONGACRE DRIVE / ASHLAND AVENUE**

SCALE: SHEET OF SHEETS STA. TO STA.

F.A.P. RTE.	SECTION	COUNTY	TOTAL SHEETS	SHEET NO.
600	(130, 130-1, 130-2)TS-3, 82-575	ST. CLAIR	47	39
			CONTRACT NO. 76R78	
		ILLINOIS FED. AID PROJECT		





**Bridge Foundation Boring Log**

Sh. 1 of 1 Sh.

PROJECT P-98-041-87 BRIDGE FA Route 600 Traffic Signal Date April 21, 1988  
 ROUTE FA 600 (Ill.159) @ Longacre Drive Bored By Larry Ford  
 SEC. 130I STA. 301+54.5 = 36+90 Checked By Robert Nebelsick

COUNTY St. Clair		Boring No. 3		Station 301+47		Offset 42' Lt. E		Surface Water El.		Groundwater El. at Completion		After _____ Hours	
Elevation	N	Qu t/s.f.	w (%)	Elevation	N	Qu t/s.f.	w (%)						
Ground Surface	584.7	0											
BROWN AND GRAY CLAYEY SILT W/LIMESTONE ROCK		1.8	15										
		2.0	14										
581.7		2.0	22										
BROWN SILTY CLAY		1.5	26										
		1.2	29										
578.7 GW		0.8	32										
BROWN AND GRAY CLAYEY SILT		0.2	31										
		0.7	32										
		1.2	31										
		1.5	31										
		1.5	33										
572.7		1.7	33										
END OF BORING													

N-Standard Penetration Test- Blows per foot to drive 2" O.D. Split Spoon Sampler 12" with 140 No. hammer falling 30".

Qu-Unconfined Compressive Strength - t/sf  
 w - Water Content - percentage of oven dry weight-%.

Type failure:  
 B - Bulge Failure  
 S - Shear Failure  
 E - Estimated Value  
 P - Penetrometer

BD 127 (Rev. 4-78)



**Bridge Foundation Boring Log**

Sh. of Sh.

PROJECT P-98-041-87 BRIDGE FA Route 600 Traffic Signal Date April 21, 1988  
 ROUTE FA 600 (Ill.159) @ Longacre Drive Bored By Larry Ford  
 SEC. 130I STA. 301+85 = 10+00 Checked By Robert Nebelsick

COUNTY St. Clair		Boring No. 4		Station 302+36		Offset 43' Rt. E		Surface Water El.		Groundwater El. at Completion		After _____ Hours	
Elevation	N	Qu t/s.f.	w (%)	Elevation	N	Qu t/s.f.	w (%)						
Ground Surface	585.8	0											
BROWN AND GRAY CLAYEY SILT W/ROCK		0.8	19										
583.8		1.0	16										
BROWN AND GRAY SILTY CLAY W/ROCK		2.5	23										
582.8		1.5	25										
DARK GRAY CLAYEY SILT		1.5	28										
581.3		1.5	26										
BROWN SILTY CLAY		1.5	29										
		1.3	29										
578.0		1.3	29										
577.3 GW		0.5	32										
BROWN AND GRAY CLAYEY SILT		0.5	30										
		0.7	30										
573.8		1.1	33										
END OF BORING													

N-Standard Penetration Test- Blows per foot to drive 2" O.D. Split Spoon Sampler 12" with 140 No. hammer falling 30".

Qu-Unconfined Compressive Strength - t/sf  
 w - Water Content - percentage of oven dry weight-%.

Type failure:  
 B - Bulge Failure  
 S - Shear Failure  
 E - Estimated Value  
 P - Penetrometer

BD 127 (Rev. 4-78)

MODEL Path: C:\Sharepoint\ITERS\INCISystems - Midwest - Chicago Construction\DOT\_PFB\_201-041\_D8 ITS\12082 - IL 159 Signal & Interconnect\CADD\Sheet Files\0812082\_ILRoute 159\_Soil Boring.dgn



USER NAME = bfunk	DESIGNED - BF	REVISED -
	DRAWN - BF	REVISED -
PLOT SCALE = 100,0000' / in.	CHECKED - AD	REVISED -
PLOT DATE = 12/21/2023	DATE - 11/10/23	REVISED -

STATE OF ILLINOIS  
 DEPARTMENT OF TRANSPORTATION

SOIL BORING LOGS  
 IL ROUTE 159 AND LONGACRE DRIVE / ASHLAND AVENUE

SCALE: SHEET OF SHEETS STA. TO STA.

F.A.P. RTE.	SECTION	COUNTY	TOTAL SHEETS	SHEET NO.
600	(130, 130-1, 130-2)TS-3, 82-575	ST. CLAIR	47	41
CONTRACT NO. 76R78				
ILLINOIS FED. AID PROJECT				

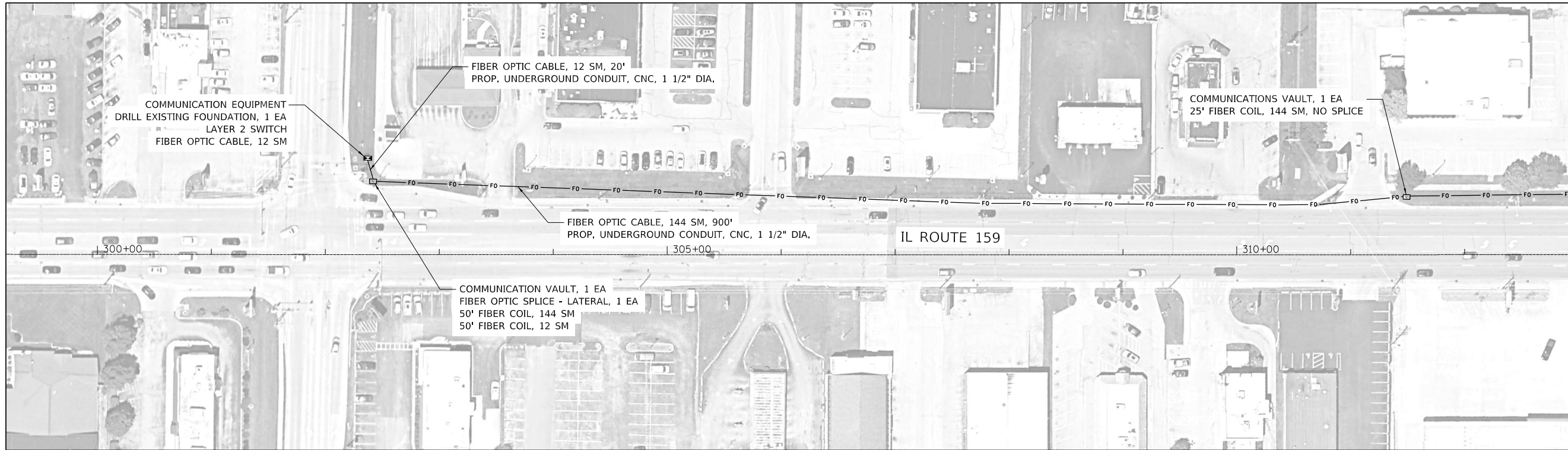

LONGACRE DR / ASHLAND AV

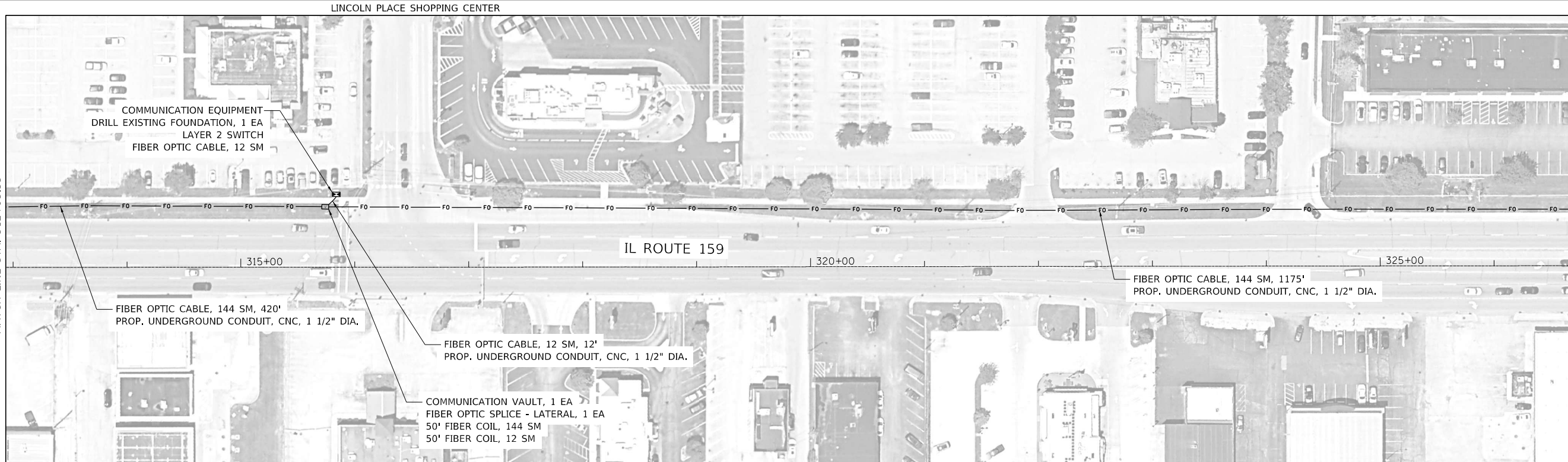

LINCOLN PLACE SHOPPING CENTER



MODEL: D:\default\ITERIS\Projects\Illinois\2024\11\159\_Signal & Interconnect\CADD\Sheet Files\0912082\_IL-Route159\_Fiber\_SHT\_01.dgn



USER NAME = adanczyk	DESIGNED - BF	REVISED -
PLOT SCALE = 100,0000 ' / in.	DRAWN - BF	REVISED -
PLOT DATE = 2/6/2024	CHECKED - ASG	REVISED -
	DATE - 11/6/23	REVISED -

**STATE OF ILLINOIS  
DEPARTMENT OF TRANSPORTATION**

**FIBER OPTIC INSTALLATION PLAN  
IL ROUTE 159**

SCALE: SHEET OF SHEETS STA. TO STA.

F.A.P. RTE.	SECTION	COUNTY	TOTAL SHEETS	SHEET NO.
600	(130, 130-1, 130-2/175-3, 82-575)	ST. CLAIR	47	42
			CONTRACT NO. 76R78	
		ILLINOIS	FED. AID PROJECT	

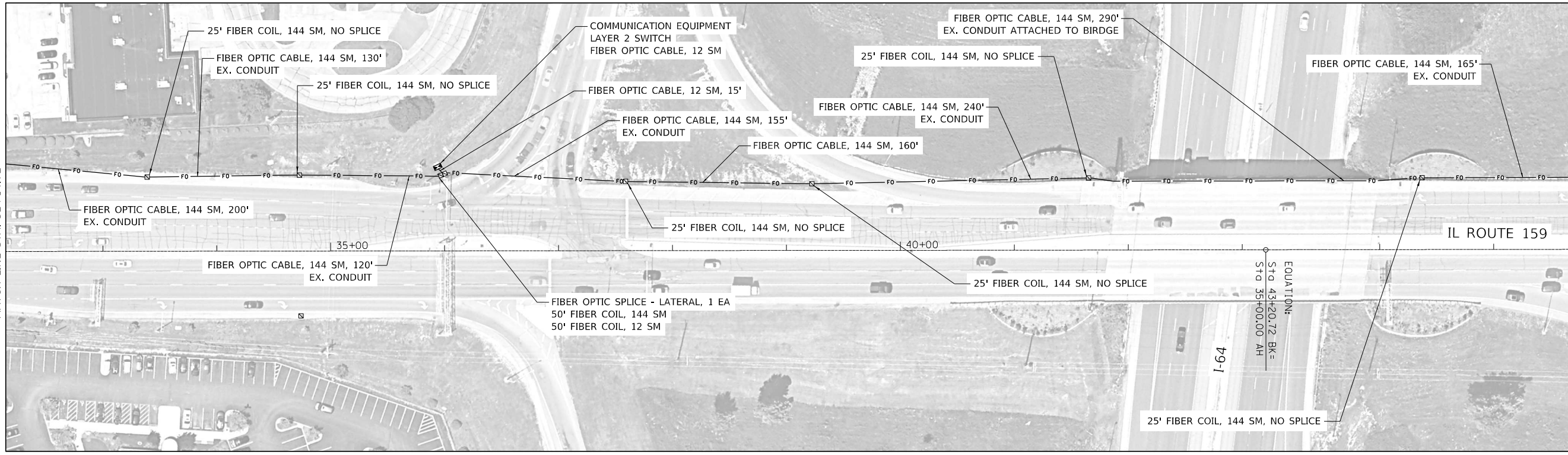
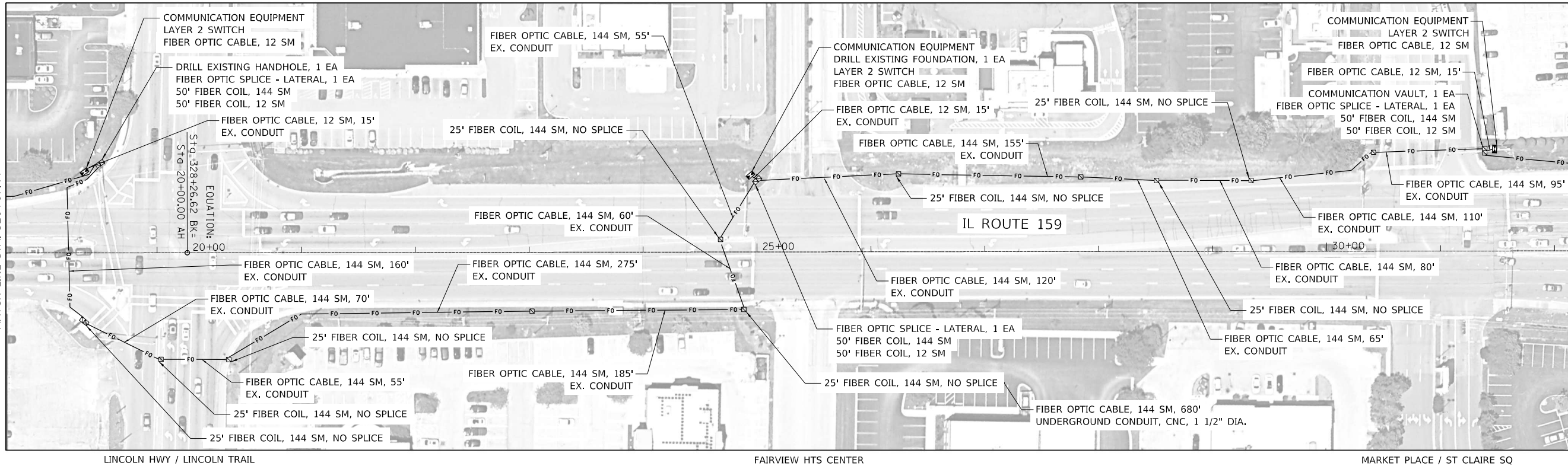

MODEL: D:\draft\...  
 FILE NAME: C:\Sharepoint\ITERIS, INC\System - Midwest - Chicago Construction\DOT\_PFB\_201-041\_D8\_T512082 - IL 159\_Signal & Interconnect\CADD\Sheet Files\IL159\_IL-Route159\_Fiber\_SHT\_03.dgn



USER NAME	= adanczyk
PLOT SCALE	= 100,0000' / in.
PLOT DATE	= 2/6/2024

DESIGNED	- BF
DRAWN	- BF
CHECKED	- ASG
DATE	- 2/1/24

REVISED	-
REVISED	-
REVISED	-
REVISED	-

**STATE OF ILLINOIS  
DEPARTMENT OF TRANSPORTATION**

<b>FIBER OPTIC INSTALLATION PLAN</b>				
<b>IL ROUTE 159</b>				
SCALE:	SHEET	OF	SHEETS	STA. TO STA.

F.A.P. RTE.	SECTION	COUNTY	TOTAL SHEETS	SHEET NO.
600	(130, 130-1, 130-2)T5-3, 82-575	ST. CLAIR	47	43
CONTRACT NO. 76R78				
ILLINOIS FED. AID PROJECT				

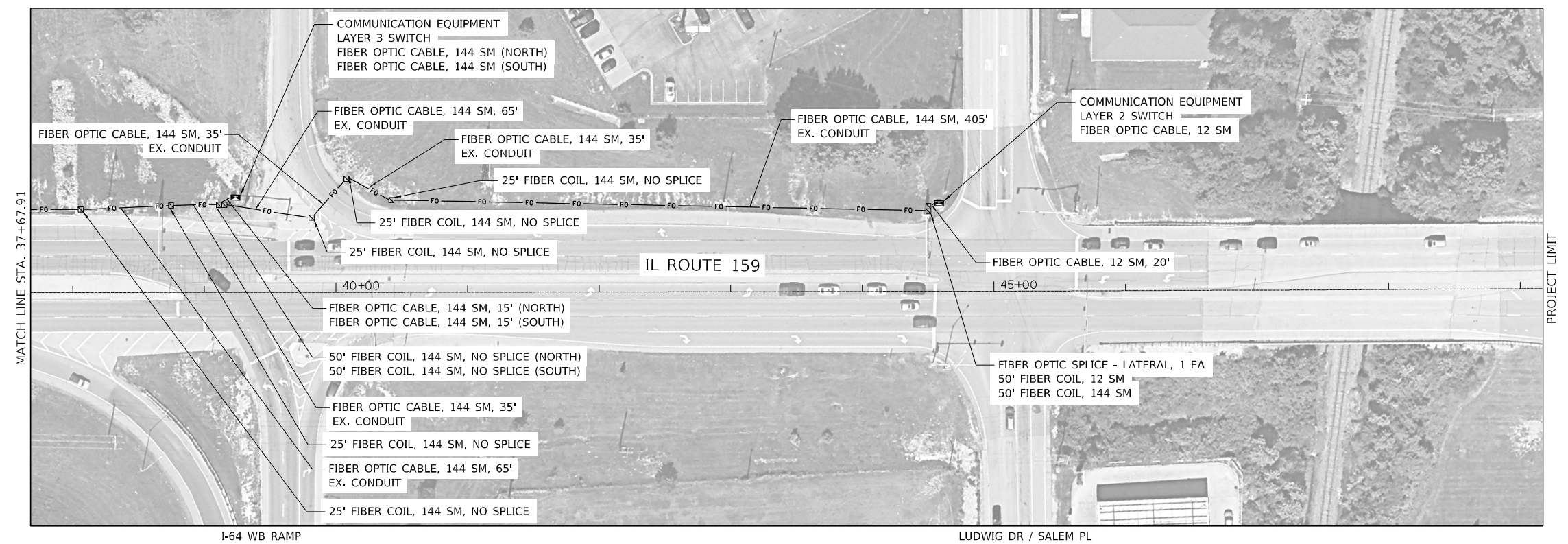

PROJECT LIMIT

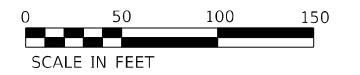

MODEL: Default  
 FILE NAME: C:\Sharepoint\ITERIS, INC\System - Midwest - Chicago Construction\DOT\_PFB\_201-041\_DB ITS\12082 - IL 159\_Signal & Interconnect\CADD\Sheet Files\03\12082\_IL\_Route 159\_Fiber\_Split\_03.dgn



USER NAME = bfunk	DESIGNED - BF	REVISED -
DRAWN - BF	REVISIONS -	
PLOT SCALE = 100,0000' / in.	CHECKED - ASG	REVISIONS -
PLOT DATE = 7/24/2025	DATE - 7/14/25	REVISIONS -

**STATE OF ILLINOIS  
 DEPARTMENT OF TRANSPORTATION**

**FIBER OPTIC INSTALLATION PLAN  
 IL ROUTE 159 - I-64**

SCALE: SHEET OF SHEETS STA. TO STA.

F.A.P. RTE.	SECTION	COUNTY	TOTAL SHEETS	SHEET NO.
600	(130, 130-1, 130-2)TS-3, 82-575	ST. CLAIR	47	44
			CONTRACT NO. 76R78	
ILLINOIS FED. AID PROJECT				

MODEL: Default  
 FILE NAME: C:\Sharepoint\ITERIS, INC\Systems - Midwest - Chicago Construction\IDOT\_PFB\_201-041\_DB\_FT512082 - IL\_159\_Signal & Interconnect\CAD\Sheet Files\0812082\_IL\_Route\_159\_0-LTS\_Fiber\_Schematic.dgn

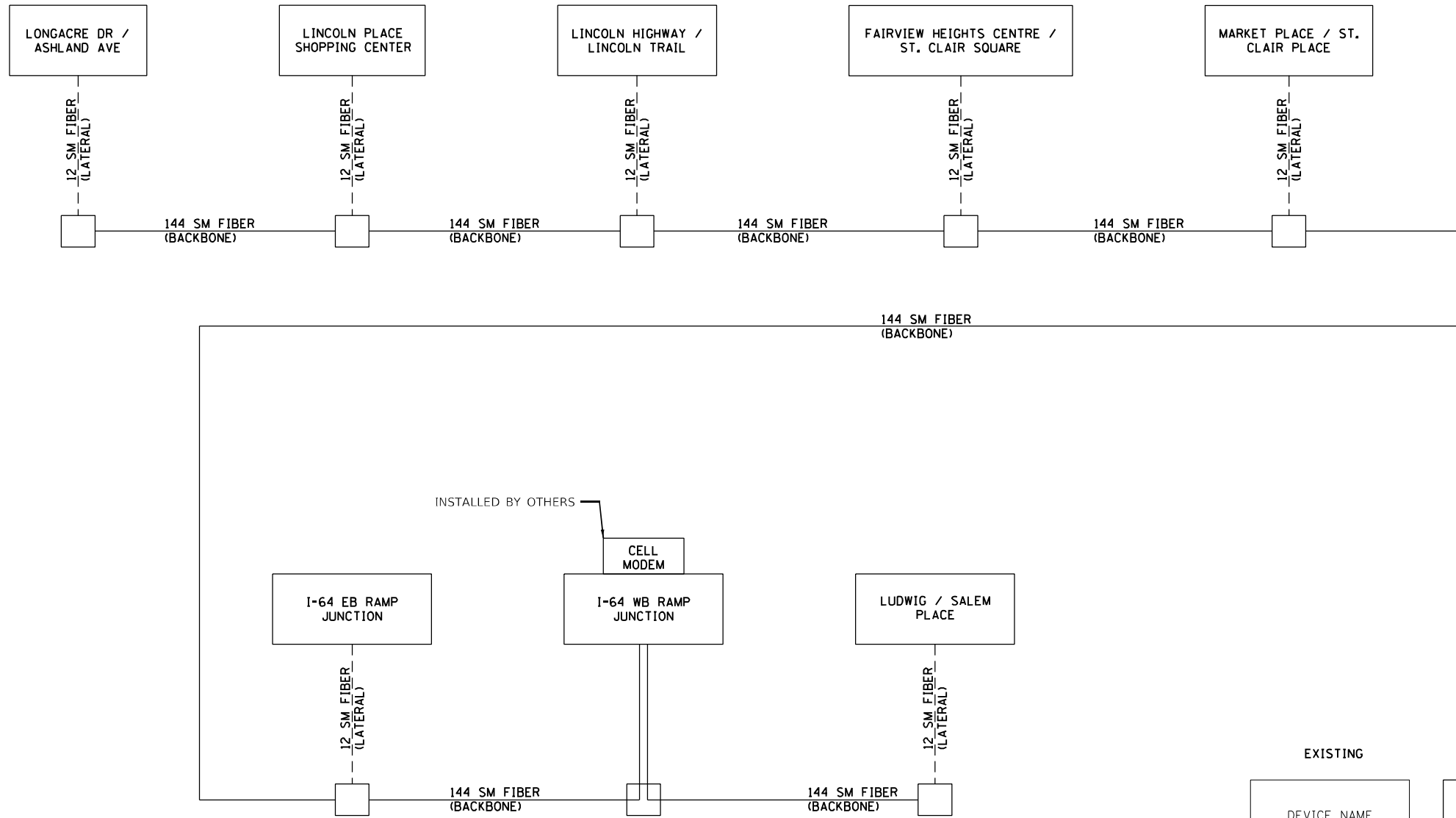

**LEGEND**

EXISTING	PROPOSED	INTERSECTION STREET NAME OR DEVICE NAME
		COMMUNICATIONS VAULT
		12 STRAND SINGLE MODE FIBER (LATERAL) CABLE
		144 STRAND SINGLE MODE FIBER (BACKBONE) CABLE



USER NAME = bfunk	DESIGNED -	REVISED -
	DRAWN -	REVISED -
PLOT SCALE = 100,0000' / in.	CHECKED -	REVISED -
PLOT DATE = 7/14/2025	DATE -	REVISED -

**STATE OF ILLINOIS  
 DEPARTMENT OF TRANSPORTATION**



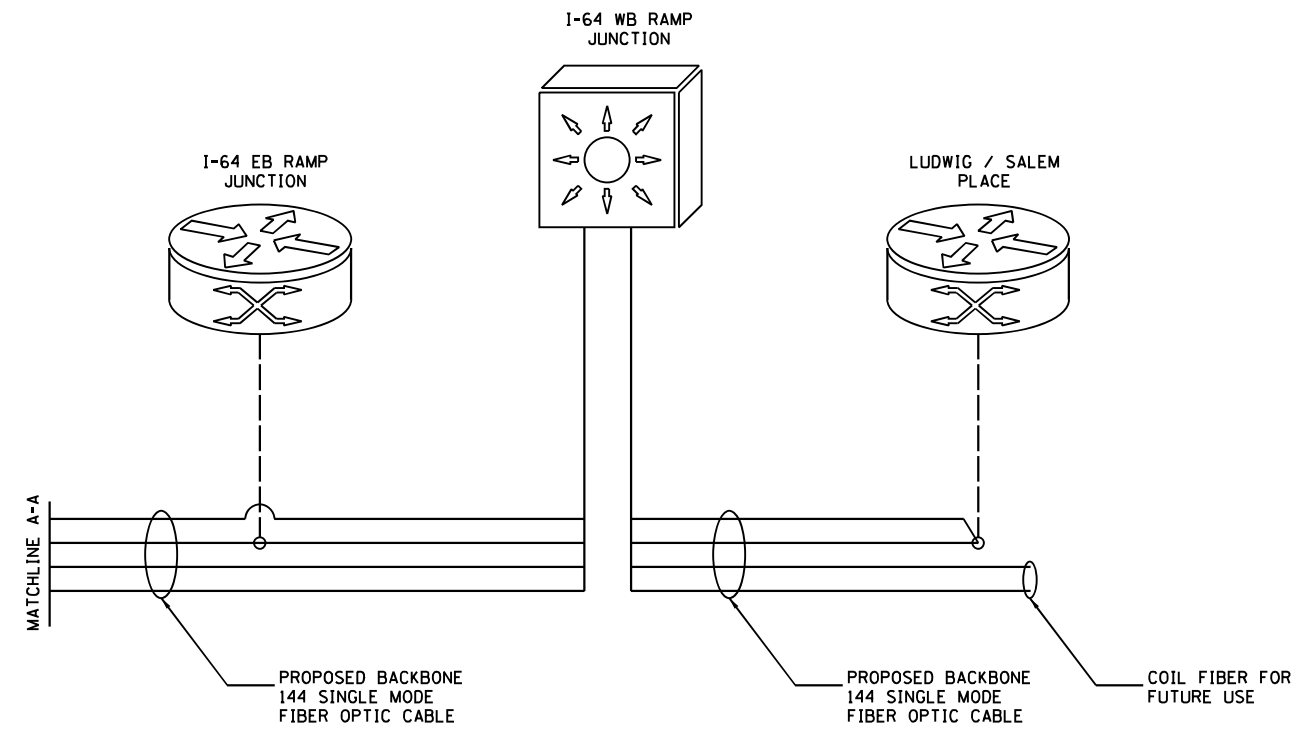
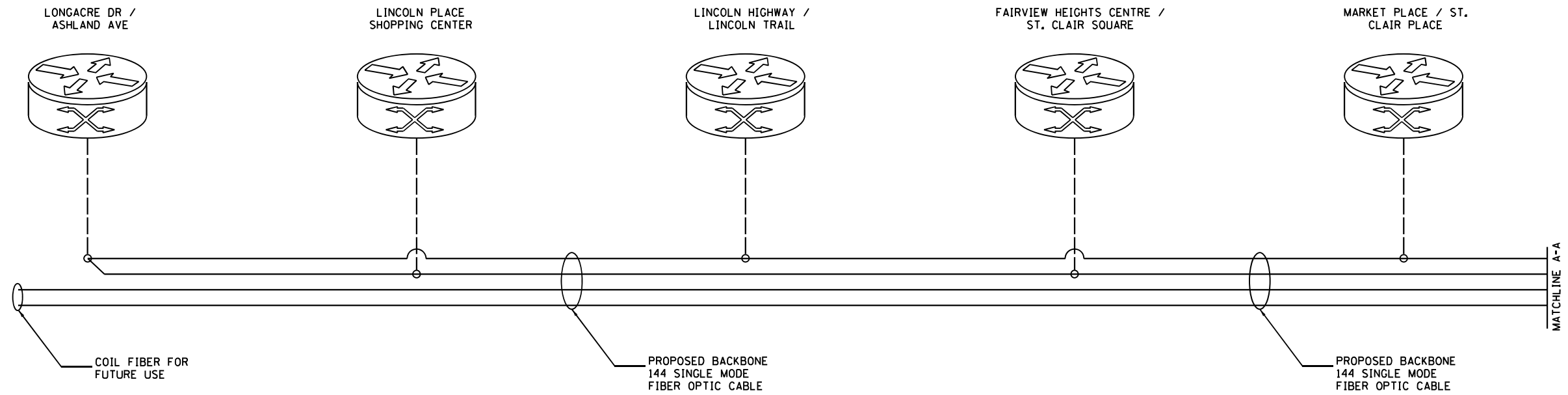

**FIBER COMMUNICATIONS SYSTEM TOPOLOGY**

SCALE: SHEET OF SHEETS STA. TO STA.

F.A.P. RTE.	SECTION	COUNTY	TOTAL SHEETS	SHEET NO.
600	(130, 130-1, 130-2)/TS-3, 82-575	ST. CLAIR	47	45
CONTRACT NO. 76R78				
ILLINOIS FED. AID PROJECT				

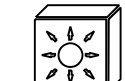

**LEGEND**

-  LAYER 2 NETWORK SWITCH
-  LAYER 3 NETWORK SWITCH
-  SPLICE LOCATION
-  12 STRAND SINGLE MODE FIBER OPTIC CABLE (LATERAL)
-  144 STRAND SINGLE MODE FIBER OPTIC CABLE (BACKBONE)

MODEL: Default  
 FILE NAME: C:\Sharepoint\ITERIS, INC\Systems - Midwest - Chicago Construction\DOT PFB, 201-041 DB ITS\12082 - IL 159-Signal & Interconnect\CAD\Sheet Files\0812082\_IL\_Route\_159\_02-ITS\_Fiber-Schematic.dgn



USER NAME = bfunk	DESIGNED -	REVISED -
	DRAWN -	REVISED -
PLOT SCALE = 100,0000' / in.	CHECKED -	REVISED -
PLOT DATE = 7/14/2025	DATE -	REVISED -

**STATE OF ILLINOIS  
DEPARTMENT OF TRANSPORTATION**

**FIBER COMMUNICATIONS SYSTEM SCHEMATIC**

SCALE: SHEET OF SHEETS STA. TO STA.

F.A.P. RTE.	SECTION	COUNTY	TOTAL SHEETS	SHEET NO.
600	(130, 130-1, 130-2)TS-3, 82-575	ST. CLAIR	47	46
CONTRACT NO. 76R78				
ILLINOIS		FED. AID PROJECT		

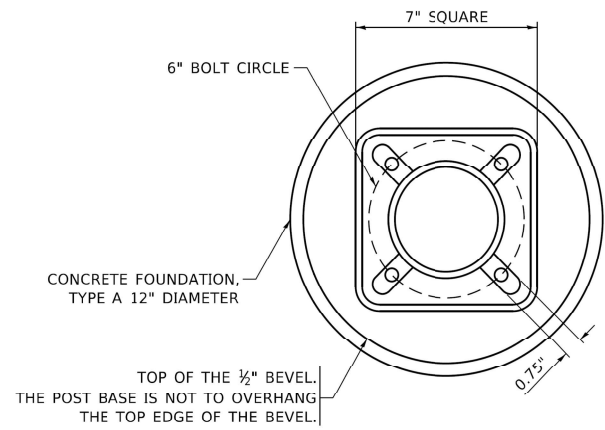

**BOLT PATTERN**

**NOTE:**

1. IF THE PEDESTRIAN SIGNAL POST FOUNDATION IS INSTALLED WITHIN OR BEHIND A BARRIER CURB, THE TOP OF THE FOUNDATION SHALL BE INSTALLED FLUSH WITH THE TOP OF THE BARRIER CURB.

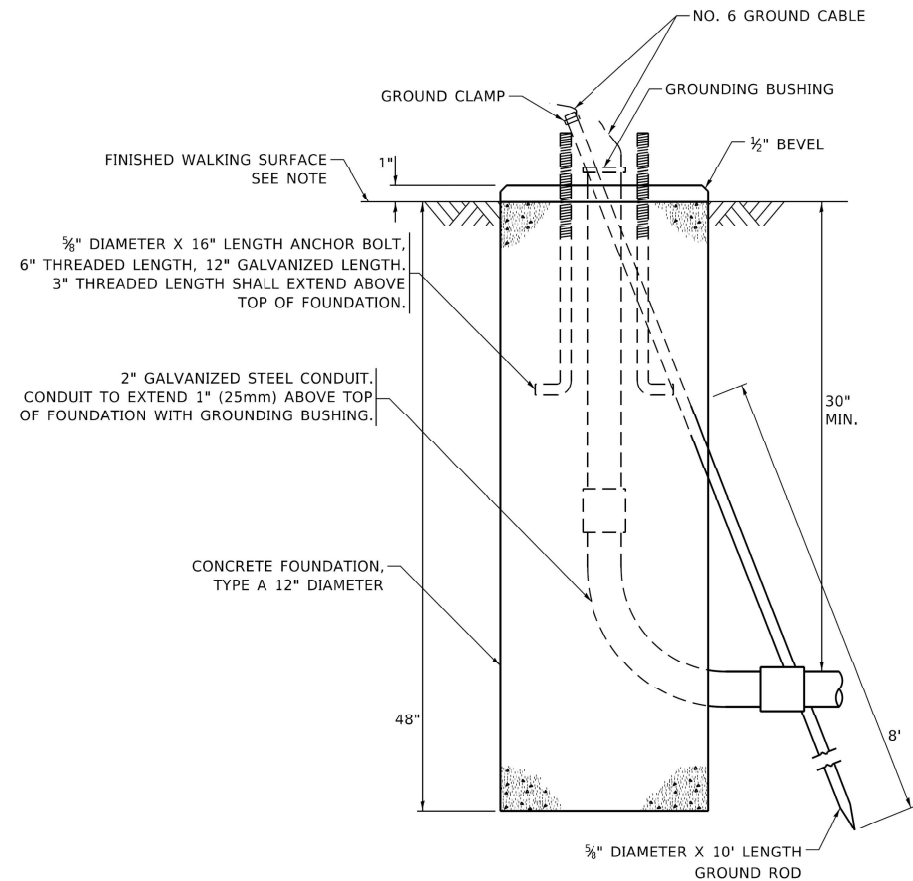

**CONCRETE FOUNDATION, TYPE A 12-INCH DIAMETER**

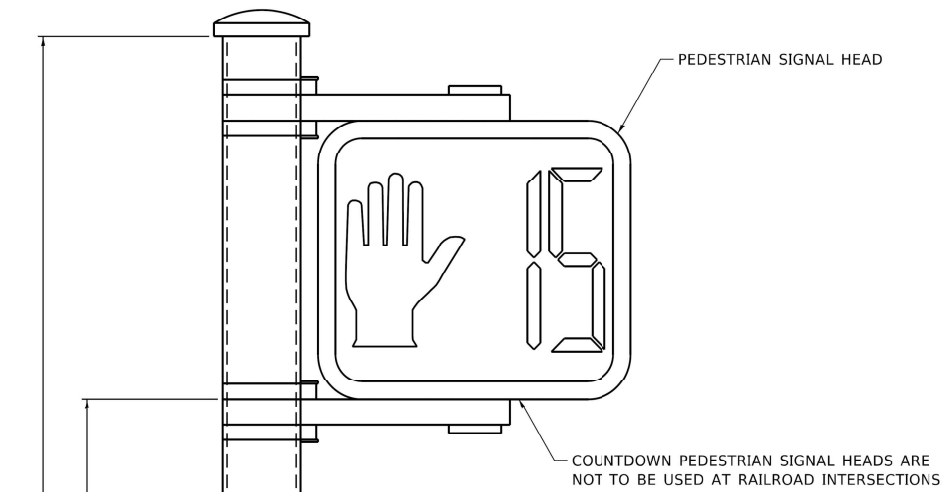

COUNTDOWN PEDESTRIAN SIGNAL HEADS ARE NOT TO BE USED AT RAILROAD INTERSECTIONS

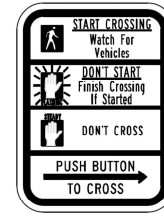

**R10-3b**

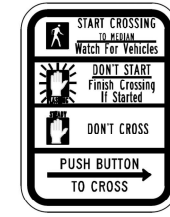

**R10-3d**

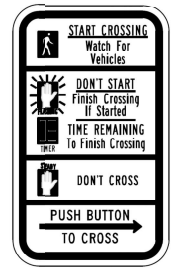

**R10-3e**

**SIGN TABLE**

SIGN	DIMENSIONS
R10-3b (RAILROAD ONLY)	9" X 12"
R10-3d (RAILROAD ONLY)	9" X 12"
R10-3e	9" X 12"

**NOTES:**

1. THE SIGN PANELS SHALL BE TYPE AP SHEETING.
2. THE ARROW ON SIGNS FOR PUSH-BUTTONS SERVING TWO DIRECTIONS ON THE SAME PHASE SHALL BE BI-DIRECTIONAL.
3. THE SIGN FOR DUAL-CALL PUSH-BUTTONS SHALL HAVE NO ARROW.

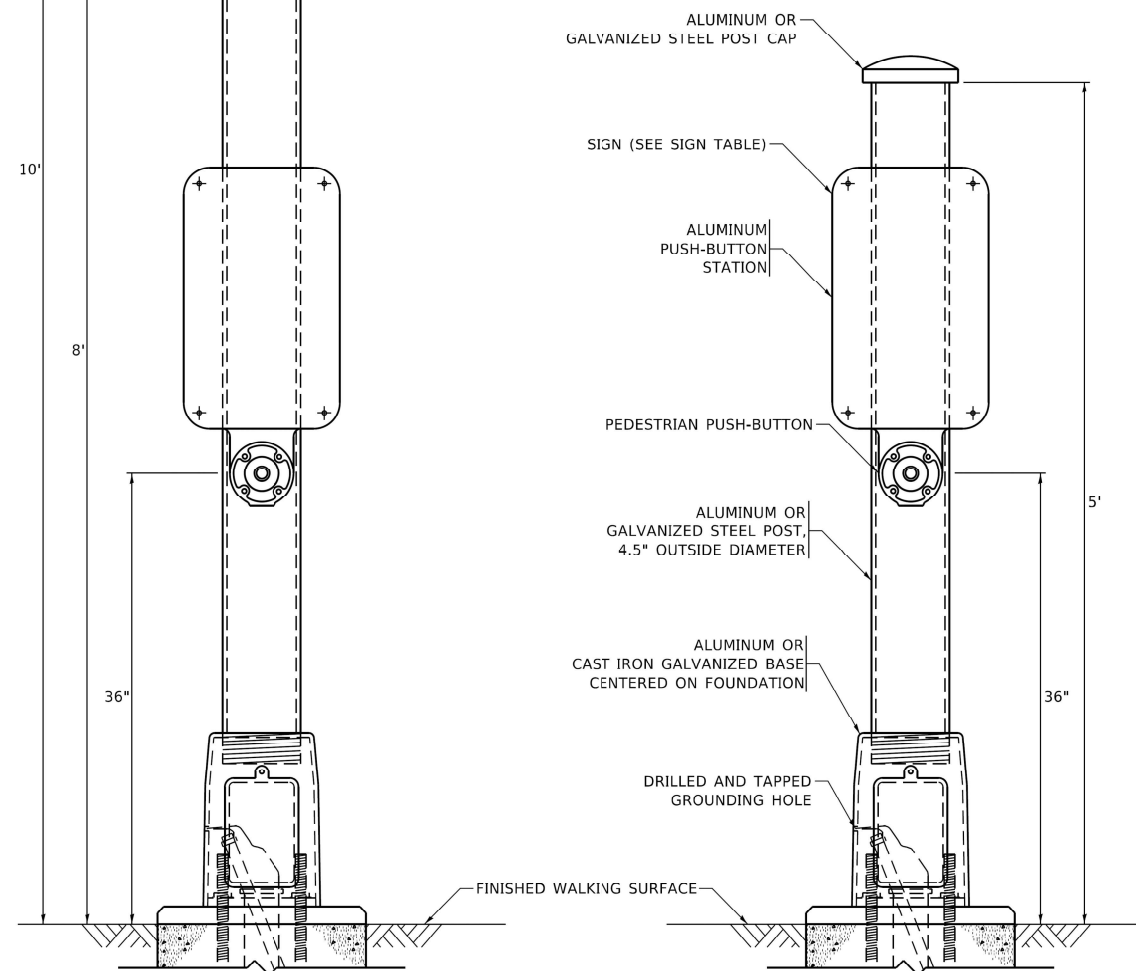

**PEDESTRIAN SIGNAL POST, 10 FT.**

**PEDESTRIAN SIGNAL POST, 5 FT.**

MODEL: Default  
FILE NAME: C:\Sharepoint\ITERIS, INC\Systems - Midwest - Chicago Construction\DOT\_PFB\_201-041\_D8 ITS\12082 - IL 159-Signal & Interconnect\CAD\Draws File\11\_159-sig-concrete\_02.dwg



USER NAME = bfunk	DESIGNED - BF	REVISED -
PLOT SCALE = 2,0000' / in.	DRAWN - BF	REVISED -
PLOT DATE = 8/5/2025	CHECKED - AD	REVISED -
	DATE - 8/5/25	REVISED -

**STATE OF ILLINOIS  
DEPARTMENT OF TRANSPORTATION**

**PEDESTRIAN PUSH BUTTON POST DETAIL**

SCALE: SHEET OF SHEETS STA. TO STA.

F.A.P. RTE.	SECTION	COUNTY	TOTAL SHEETS	SHEET NO.
600	(130, 130-1, 130-2)TS-3, 82-575	ST. CLAIR	47	47
CONTRACT NO. 76R78				
ILLINOIS		FED. AID PROJECT		