

INDEX OF SHEETS

- 1 COVER SHEET
- 2 COMMITMENTS AND JOB SPECIFIC NOTES
- 3 SUMMARY OF QUANTITIES
- 4 LOCATION 1 MAP
- 5 LINE DIAGRAM (LOCATION 1)
- 6 LOCATION 2 MAP
- 7 LINE DIAGRAM (LOCATION 2)
- 8-9 PAVEMENT MARKING PLAN (LOCATION 2)
- 10 LOCATION 3 MAP
- 11 LINE DIAGRAM (LOCATION 3)
- 12 LOCATION 4 MAP
- 13 LINE DIAGRAM (LOCATION 4)
- 14 LOCATION 5 MAP
- 15 LINE DIAGRAM (LOCATION 5)
- 16-20 SCHEDULE OF QUANTITIES
- 21 CRACK & JOINT SEALING DETAIL
- 22-23 PAVEMENT MARKING DETAILS

HIGHWAY STANDARDS

- 701301-04 701411-09
- 701306-04 701426-09 701701-10
- 701311-03 701456-05 701901-09
- 701400-12 701601-09
- 701406-13 701602-10

DISTRICT STANDARDS

- 452001
- 780001

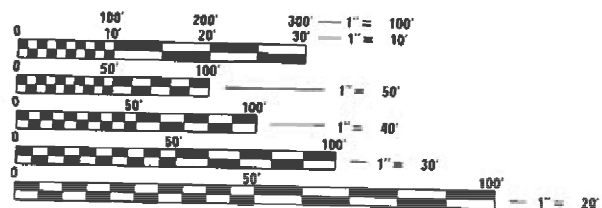

FULL SIZE PLANS HAVE BEEN PREPARED USING STANDARD ENGINEERING SCALES. REDUCED SIZED PLANS WILL NOT CONFORM TO STANDARD SCALES. IN MAKING MEASUREMENTS ON REDUCED PLANS, THE ABOVE SCALES MAY BE USED.

J.U.L.I.E.
JOINT UTILITY LOCATION INFORMATION FOR EXCAVATORS
1-800-892-0123
OR 811

SQUAD LEADER: MICHAEL JACOBS (309) 671-3460
PROJECT MANAGER: RAYMOND SAMARA (309) 671-3460

CONTRACT NO. 68H26
CATALOG NO. 036343-00D

STATE OF ILLINOIS
DEPARTMENT OF TRANSPORTATION

PROPOSED
HIGHWAY PLANS

VARIOUS ROUTES
D4 CRACK & JOINT SEALING 2024
PROJECT NHPP-STP-498D(999)
VARIOUS COUNTIES

C-94-003-23



F.A.P. RTE.	SECTION	COUNTY	TOTAL SHEETS	SHEET NO.
VAR	D4 CRACK & JOINT SEALING	VARIOUS	23	1
		ILLINOIS	CONTRACT NO. 68H26	

D-94-003-23



PROJECT DESCRIPTION:

CRACK AND JOINT SEALING ON VARIOUS ROUTES IN VARIOUS COUNTIES IN DISTRICT 4

STATE OF ILLINOIS
DEPARTMENT OF TRANSPORTATION

SUBMITTED February 2, 2024
[Signature]
REGIONAL ENGINEER

March 22, 2024 [Signature]
ENGINEER OF DESIGN AND ENVIRONMENT

March 22, 2024 [Signature]
DIRECTOR OF HIGHWAYS PROJECT IMPLEMENTATION

PRINTED BY THE AUTHORITY
OF THE STATE OF ILLINOIS

COMMITMENTS

Commitments are not to be altered without the written consent of all parties to which the commitment was made.

No commitments have been made for this project.

JOB JOB SPECIFIC NOTES

Care shall be exercised to keep sealant off existanting pavement markings. See note #6 in district CADD STANDARD 452001-D4 (included in plans) regarding how to treat cracks near or in pavement markings.

All dirt and debris created by the routing operation shall be cleaned from the pavement and paved shoulders at the end of the day's operations according to article 107.15 of the standard specifcations.

Locations for proposed "crack routing and filling" are numbered by priority. Locations shall be completed in this order only.

LOCATION 2: NO LANE CLOSURES BEFORE 8:30 AM AND AFTER 3:30 PM

LOCATION 3: NO PROPOSED PAVEMENT MARKINGS – WILL BE COMPLETED BY OPERATIONS

MODEL: Default
 FILE: Mainfile.pxl
 SUBJECT: pw.bentley.com/PW/IDOT/Documents/IDOT Offices/District_4/Project/ID4_68H26/CADD/Draws/CAD/Sheets/68H26

USER NAME = Brian.Bouris	DESIGNED -	REVISED -
	DRAWN -	REVISED -
PLOT SCALE = 100,0000 ' / in.	CHECKED -	REVISED -
PLOT DATE = 2/2/2024	DATE -	REVISED -

**STATE OF ILLINOIS
DEPARTMENT OF TRANSPORTATION**

COMMITMENTS AND JOB SPECIFIC NOTES

SCALE: SHEET OF SHEETS STA. TO STA.

F.A.P. RTE.	SECTION	COUNTY	TOTAL SHEETS	SHEET NO.
VAR	D4 CRACK & JOINT SEALING	VARIOUS	23	2
			CONTRACT NO. 68H26	
		ILLINOIS	FED. AID PROJECT	



PROPOSED IMPROVEMENT ENDS
STA. 363+90.00

SN 048-0073 & SN 048-0074
US 34 OVER IL 164
STA. 350+38

IL 164

W. MAIN ST.

RAMP C

RAMP A

RAMP B

RAMP D

Sta. Eq. 343+65.05 (BK)=
344+67.08 (AH)

STRUCTURE OMISSIONS
 (EB US 34) STA 894+29 TO 896+31
 (EB US 34) STA 350+15 TO 351+95
 (WB US 34) STA 892+42 TO 894+83
 (WB US 34) STA 350+29 TO 352+15
 (MAIN ST RAMP C) STA 21+09 TO 23+50
 (MAIN ST RAMP D) STA 0+00 TO 1+44

SN048-0077
CEDAR CREEK
STA. 895+12

STA. EQUATION
 EBL STA. 898+54.97(BK)=
STA. 333+50.00(AH)
 WBL STA. 898+54.97(BK)=
STA. 333+50.00(AH)

WARREN COUNTY LINE
KNOX COUNTY LINE
RURAL URBAN

US 34

SN 094-0029 165TH ST. OVER US 34
STA. 703+00

STA. EQUATION
 STA. 712+50 (BK)=
STA. 710+00 (AH)

STA. 781+22
SN048-0078

RAMP B
STA. 0+00.00
TO
24+00.11

RAMP A
STA. 0+00.00
TO
10+85.32

RAMP C
STA. 0+00
TO
20+08.98

RAMP D
STA. 0+00.00
TO
22+93.11

PROPOSED IMPROVEMENT
BEGIN
STA. 542+00

STA. 564+00
CH 15 (140TH ST)

MODEL: Default
 FILE NAME: \\sddict-cw-beadley.com\PIV\DOT\Documents\DOT Office\Bouris\dot\419023\104_68H26\CAD\DATA\CAD\Sheet68H26

USER NAME = Brian Bouris	DESIGNED -	REVISED -
PLOT SCALE = 100,0000' / in.	DRAWN -	REVISED -
PLOT DATE = 2/2/2024	CHECKED -	REVISED -
	DATE -	REVISED -

**STATE OF ILLINOIS
DEPARTMENT OF TRANSPORTATION**

LINE DIAGRAM (LOCATION 1)

SCALE: SHEET OF SHEETS STA. TO STA.

F.A.P. RTE.	SECTION	COUNTY	TOTAL SHEETS	SHEET NO.
VAR	D4 CRACK & JOINT SEALING	VARIOUS	23	5
			CONTRACT NO. 68H26	
ILLINOIS FED. AID PROJECT				

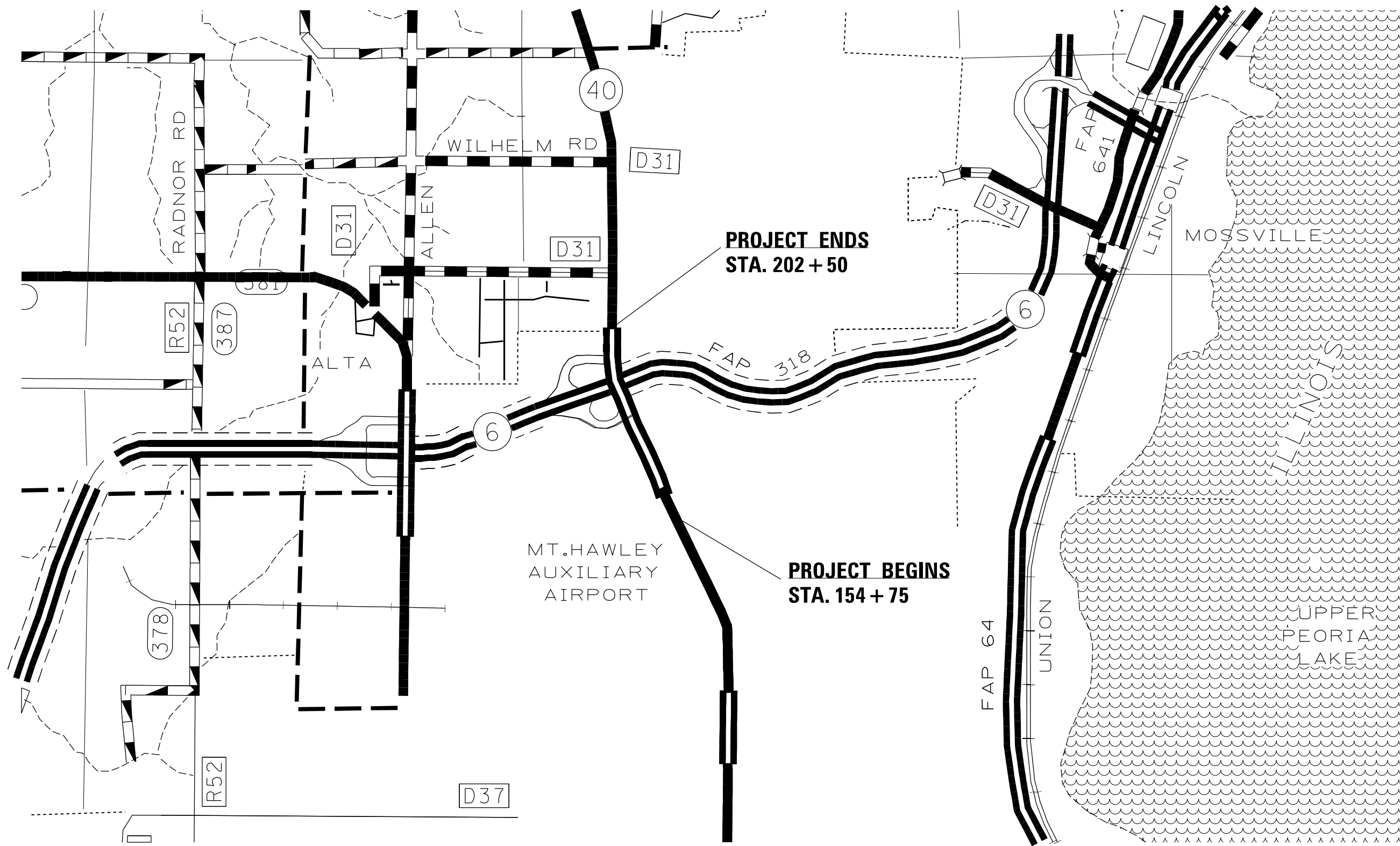

MODEL: Default
 FILE: \\mupc-pw-backend.com\FW\DOT\Documents\DOT Office\Director_4\Projects\104_68H26\CADD\Drawings\Sheet68H26

USER NAME = Brian,Bouris	DESIGNED -	REVISED -
PLOT SCALE = 100,0000' / in.	DRAWN -	REVISED -
PLOT DATE = 2/2/2024	CHECKED -	REVISED -
	DATE -	REVISED -

**STATE OF ILLINOIS
DEPARTMENT OF TRANSPORTATION**

LOCATION 2 MAP

SCALE: SHEET OF SHEETS STA. TO STA.

F.A.P. RTE.	SECTION	COUNTY	TOTAL SHEETS	SHEET NO.
VAR	D4 CRACK & JOINT SEALING	VARIOUS	23	6
			CONTRACT NO. 68H26	
		ILLINOIS	FED. AID PROJECT	



NHPP ← → STBG

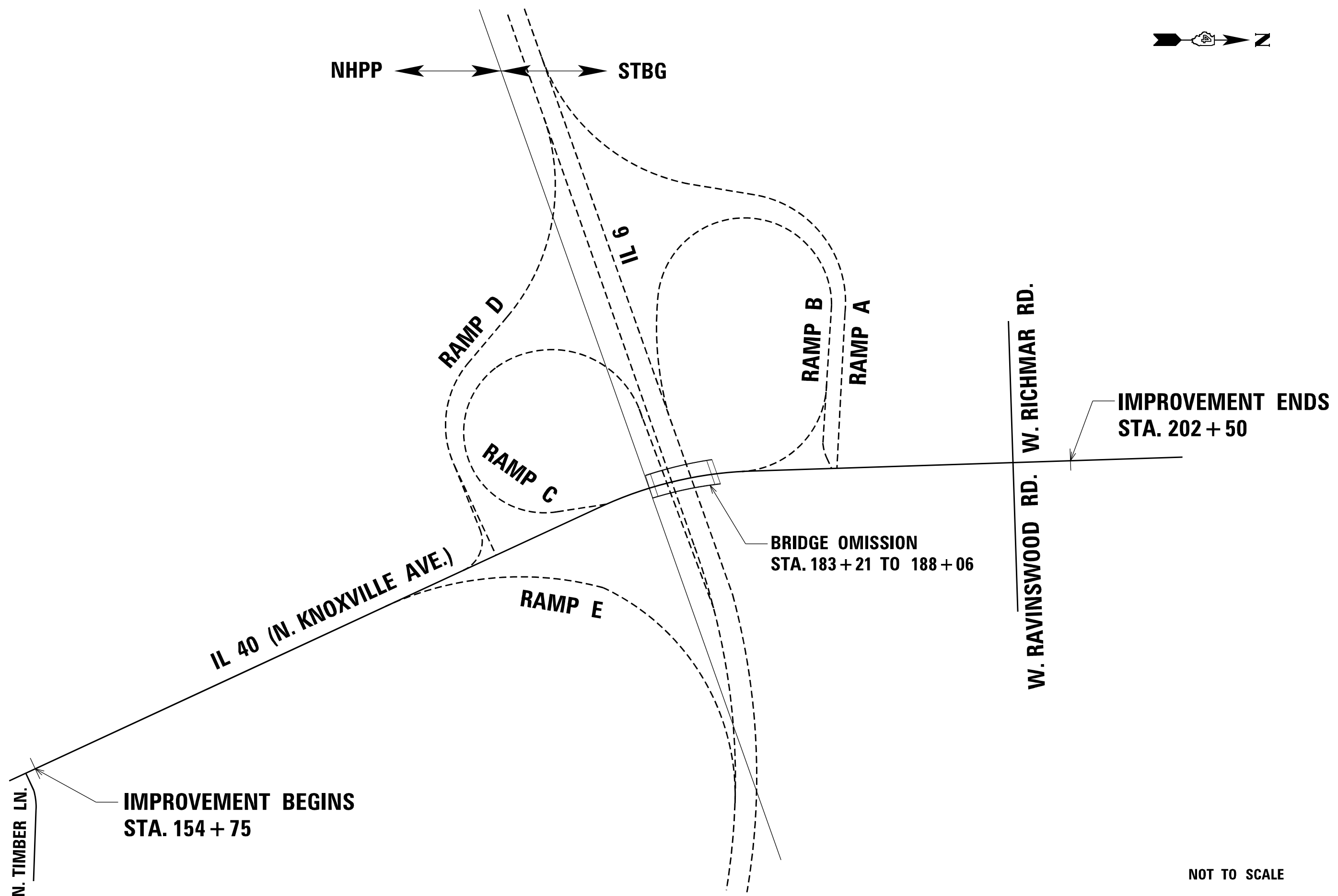

IMPROVEMENT ENDS
STA. 202 + 50

BRIDGE OMISSION
STA. 183 + 21 TO 188 + 06

IMPROVEMENT BEGINS
STA. 154 + 75

NOT TO SCALE

MODEL: Default
FILE: \\mde\p\project\aw_bentley.com\PIV\DOT\Documents\1\DOT_Offices\Director_4\Project\104_68H26\CADD\Draws\CAD\Sheet\68H26

USER NAME = Brian.Bouris	DESIGNED -	REVISED -
PLOT SCALE = 100,0000' / in.	DRAWN -	REVISED -
PLOT DATE = 2/2/2024	CHECKED -	REVISED -
	DATE -	REVISED -

STATE OF ILLINOIS
DEPARTMENT OF TRANSPORTATION

LINE DIAGRAM (LOCATION 2)

SCALE: SHEET OF SHEETS STA. TO STA.

F.A.P. RTE.	SECTION	COUNTY	TOTAL SHEETS	SHEET NO.
VAR	D4 CRACK & JOINT SEALING	VARIOUS	23	7
			CONTRACT NO. 68H26	
ILLINOIS FED. AID PROJECT				

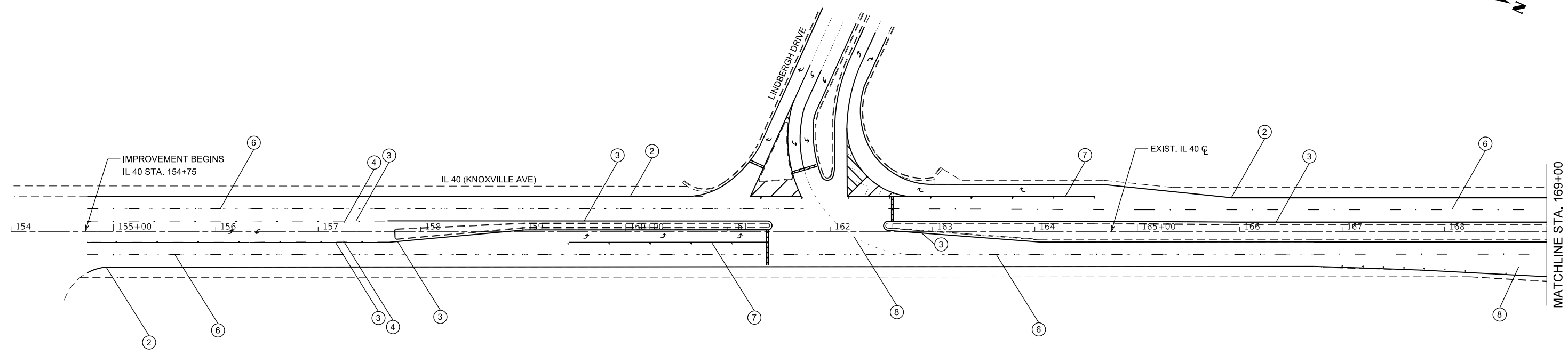

THERMOPLASTIC LEGEND

②	4" SOLID WHITE
③	4" SOLID YELLOW
④	4" SKIP-DASH YELLOW
⑤	4" SOLID DOUBLE YELLOW
⑥	6" SKIP-DASH WHITE
⑦	8" SOLID WHITE
⑧	8" DOTTED WHITE

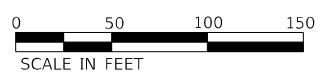
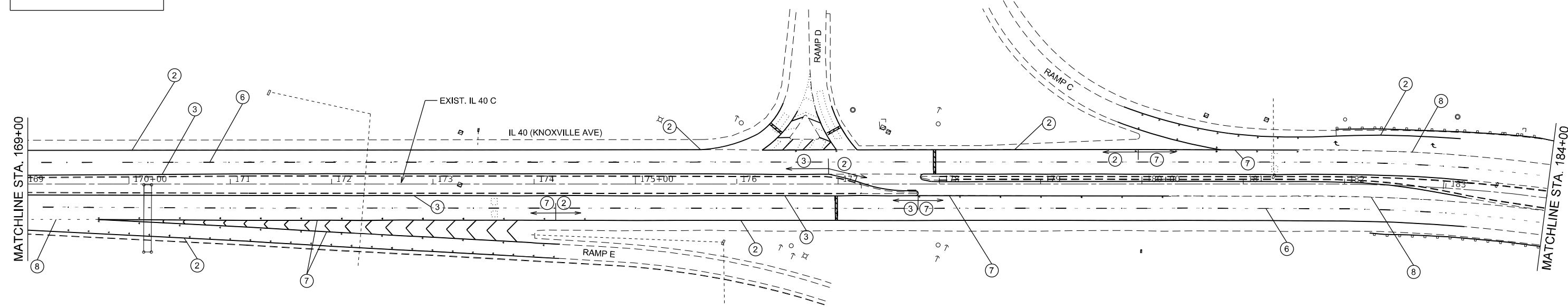

MODEL: Default
 FILE: \\mamec-pw-bentley.com\FWIDOT\Documents\DOT Office\Director_68H26\CADD\Drawings\Drawings\68H26

USER NAME = Brian.Bouris	DESIGNED -	REVISED -
PLOT SCALE = 100,0000' / in.	DRAWN -	REVISED -
PLOT DATE = 2/2/2024	CHECKED -	REVISED -
	DATE -	REVISED -

STATE OF ILLINOIS
DEPARTMENT OF TRANSPORTATION

PAVEMENT MARKING PLAN
(LOCATION 2)

SCALE:	SHEET	OF	SHEETS	STA.	TO	STA.
--------	-------	----	--------	------	----	------

F.A.P. RTE.	SECTION	COUNTY	TOTAL SHEETS	SHEET NO.
VAR	D4 CRACK & JOINT SEALING	VARIOUS	23	8
			CONTRACT NO. 68H26	
		ILLINOIS	FED. AID PROJECT	

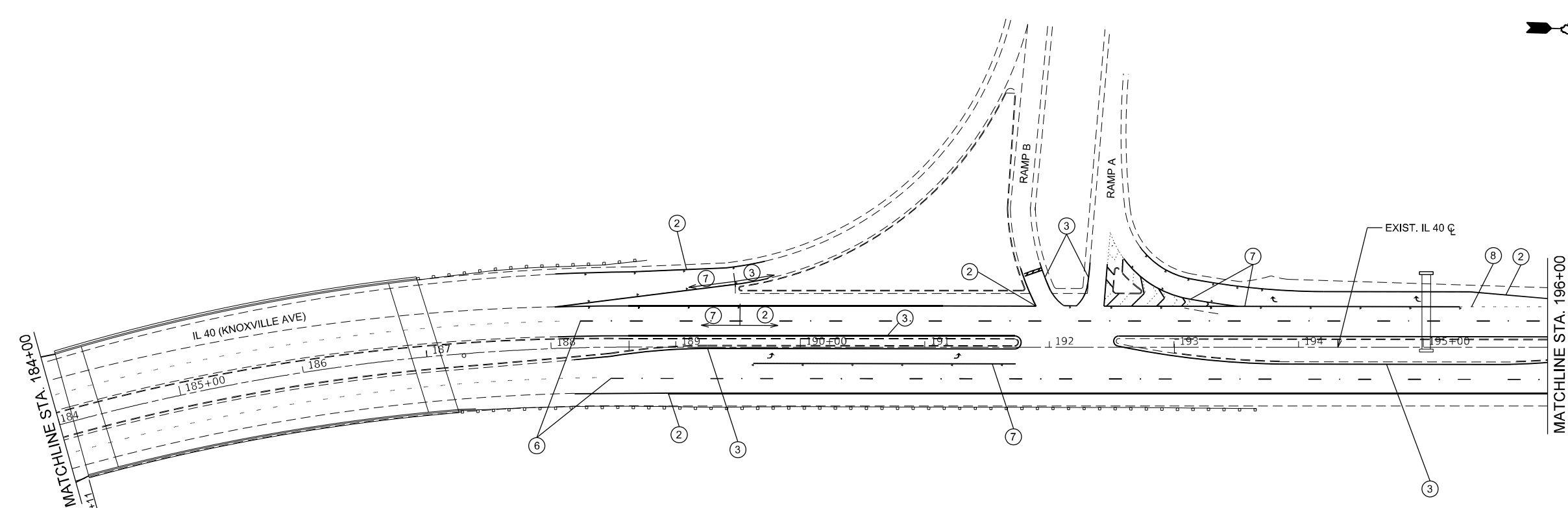

THERMOPLASTIC LEGEND

②	4" SOLID WHITE
③	4" SOLID YELLOW
④	4" SKIP-DASH YELLOW
⑤	4" SOLID DOUBLE YELLOW
⑥	6" SKIP-DASH WHITE
⑦	8" SOLID WHITE
⑧	8" DOTTED WHITE

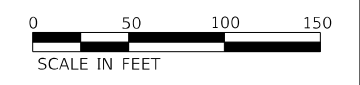
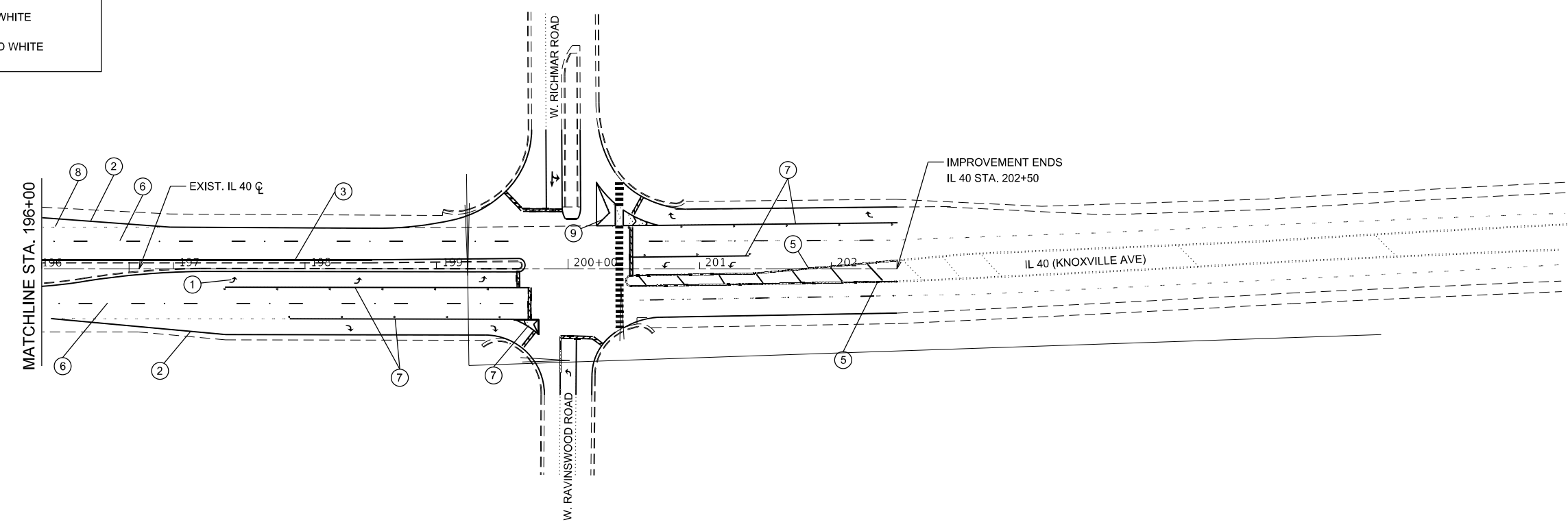

MODEL: Default
 FILE: \\mde\p\project\68H26\p\68H26\CADD\Drawings\68H26\68H26\68H26.dwg
 PROJECT: 68H26
 SHEET: 9
 DATE: 2/2/2024

USER NAME = Brian.Bouris	DESIGNED -	REVISED -
PLOT SCALE = 100,0000' / in.	DRAWN -	REVISED -
PLOT DATE = 2/2/2024	CHECKED -	REVISED -
	DATE -	REVISED -

STATE OF ILLINOIS
DEPARTMENT OF TRANSPORTATION

PAVEMENT MARKING PLAN
(LOCATION 2)

SCALE:	SHEET	OF	SHEETS	STA.	TO	STA.
--------	-------	----	--------	------	----	------

F.A.P. RTE.	SECTION	COUNTY	TOTAL SHEETS	SHEET NO.
VAR	D4 CRACK & JOINT SEALING	VARIOUS	23	9
			CONTRACT NO. 68H26	
ILLINOIS FED. AID PROJECT				

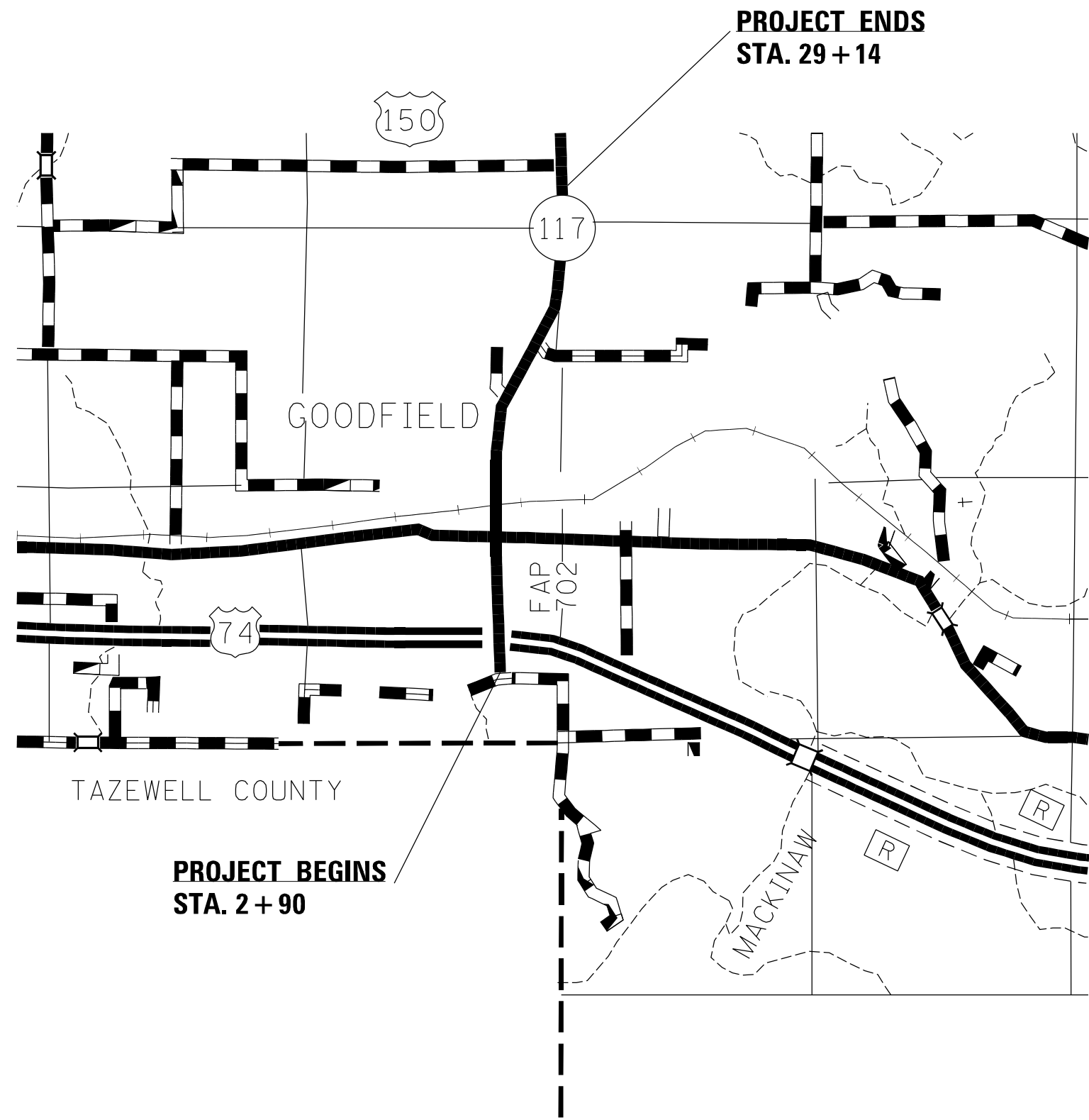

MODEL: Default
 FILE NAME: p:\ultra-cw-bead\fy.com\PIV\DOT\Documents\DOT Office\Dir\ret. 4\Project\ID4_68H26\CADD\DATA\CAD\Sheet468H26

USER NAME = Brian,Bouris	DESIGNED -	REVISED -
	DRAWN -	REVISED -
PLOT SCALE = 100,0000' / in.	CHECKED -	REVISED -
PLOT DATE = 2/2/2024	DATE -	REVISED -

STATE OF ILLINOIS
DEPARTMENT OF TRANSPORTATION

LOCATION 3 MAP

SCALE: SHEET OF SHEETS STA. TO STA.

F.A.P. RTE.	SECTION	COUNTY	TOTAL SHEETS	SHEET NO.
VAR	D4 CRACK & JOINT SEALING	VARIOUS	23	10
			CONTRACT NO. 68H26	
		ILLINOIS	FED. AID PROJECT	

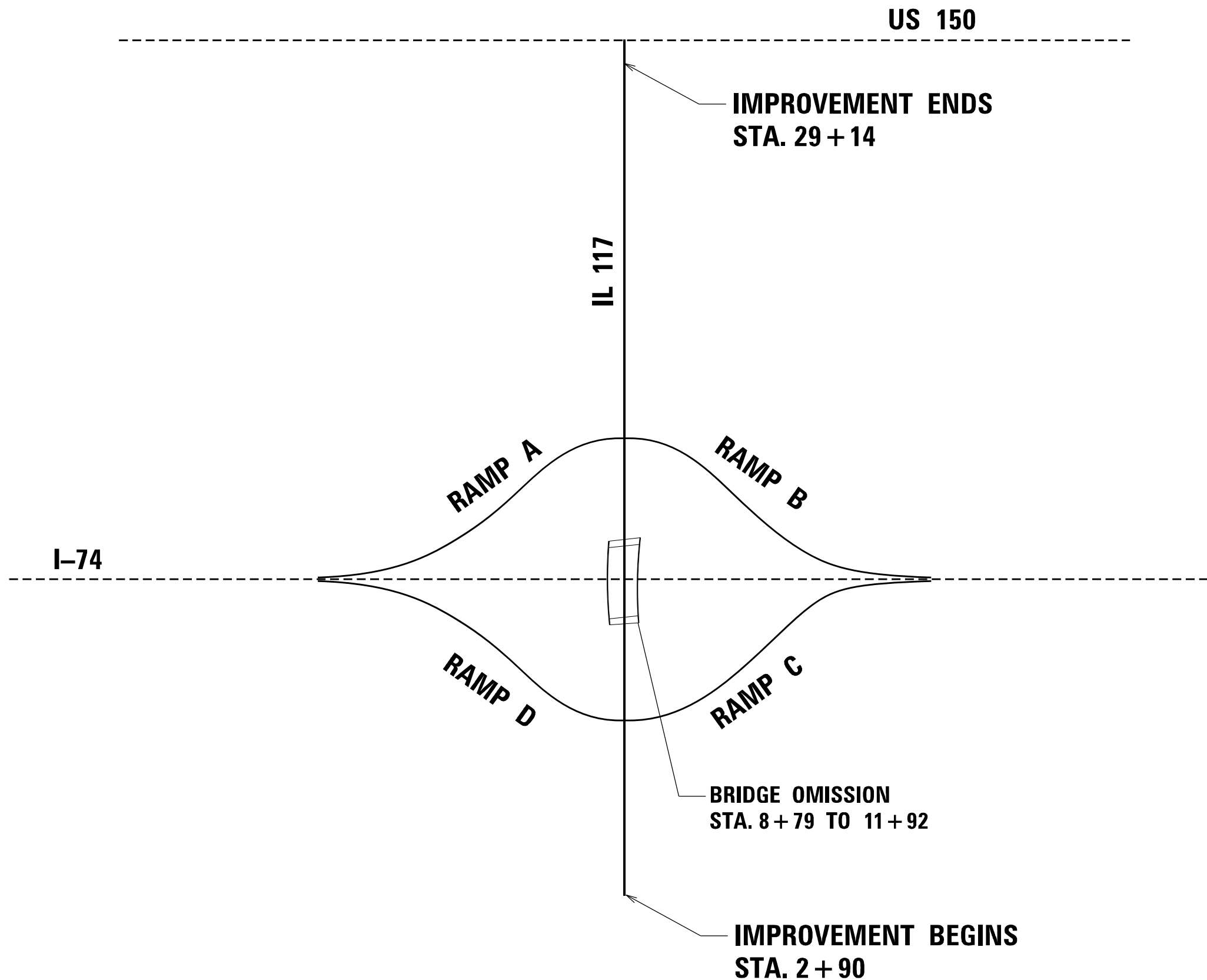
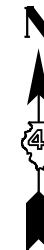

MODEL: Default
 FILE: \\mfrs-pw-bentley.com\PW\DOT\Documents\DOT_offices\Director_4\Project\104_68H26\CADD\Draws\CAD\Draws\68H26

USER NAME = Brian.Bouris	DESIGNED -	REVISED -
	DRAWN -	REVISED -
PLOT SCALE = 100,0000' / in.	CHECKED -	REVISED -
PLOT DATE = 2/2/2024	DATE -	REVISED -

STATE OF ILLINOIS
DEPARTMENT OF TRANSPORTATION

LINE DIAGRAM (LOCATION 3)

SCALE: SHEET OF SHEETS STA. TO STA.

F.A.P. RTE.	SECTION	COUNTY	TOTAL SHEETS	SHEET NO.
VAR	D4 CRACK & JOINT SEALING	VARIOUS	23	11
			CONTRACT NO. 68H26	
		ILLINOIS	FED. AID PROJECT	

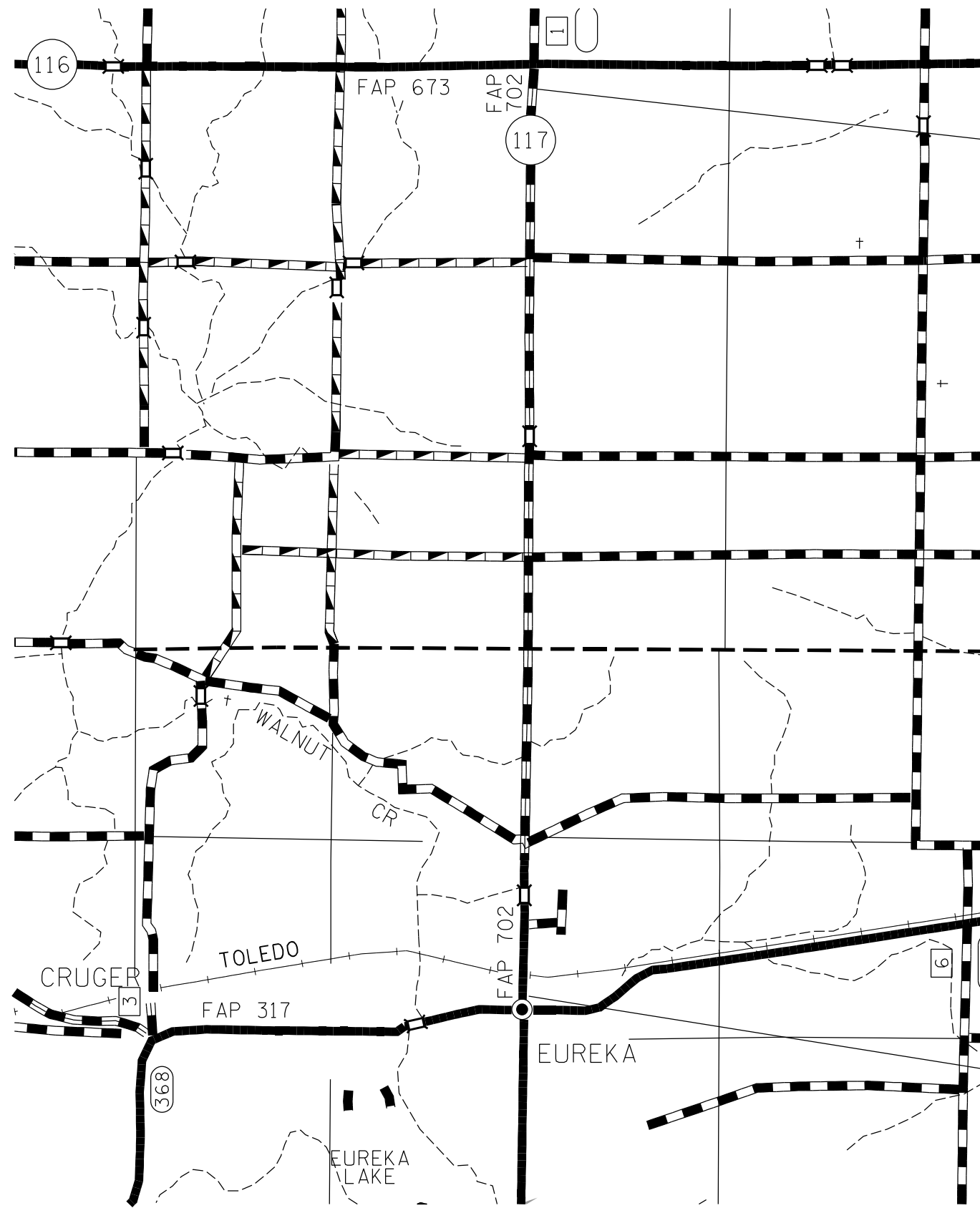

**PROJECT ENDS
STA. 241 + 53**

**PROJECT BEGINS
STA. 128 + 90**

MODEL: Default
 FILE: \\nafe-pw-bentley.com\P\DOT\Documents\DOT Office\Dir\ret_4\Project\104_68H26\CADD\Drawn\CD\Sheet68H26

USER NAME = Brian,Bouris	DESIGNED -	REVISED -
DRAWN -	REVISED -	
PLOT SCALE = 100,0000' / in.	CHECKED -	REVISED -
PLOT DATE = 2/2/2024	DATE -	REVISED -

**STATE OF ILLINOIS
DEPARTMENT OF TRANSPORTATION**

LOCATION 4 MAP				
SCALE:	SHEET	OF	SHEETS	STA. TO STA.

F.A.P. RTE.	SECTION	COUNTY	TOTAL SHEETS	SHEET NO.
VAR	D4 CRACK & JOINT SEALING	VARIOUS	23	12
			CONTRACT NO. 68H26	
		ILLINOIS	FED. AID PROJECT	



← STA. INCREASE TO THE SOUTH STA. INCREASE TO THE NORTH →

← STA. 59 + 45 →
URBAN RURAL

BEGIN IMPROVEMENT
STA. 128 + 90

END IMPROVEMENT
241 + 53

STATION EQUATION
14 + 02.3 = 106 + 23

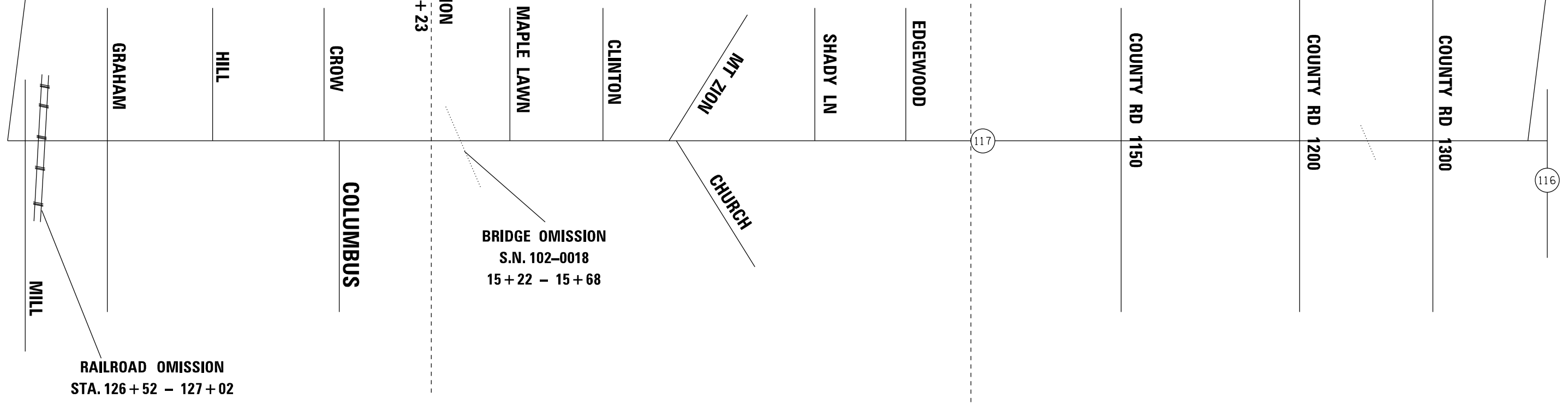

MODEL: Default
 FILE: NAME: p:\ultra-cw-beadefy.com\P\INDOT\Documents\INDOT_offices\Dir\rdet_4\Project\104_68H26\CADD\Draws\CAD\Sheet\68H26

USER NAME = Brian,Bouris	DESIGNED -	REVISED -
	DRAWN -	REVISED -
PLOT SCALE = 100,0000' / in.	CHECKED -	REVISED -
PLOT DATE = 2/2/2024	DATE -	REVISED -

STATE OF ILLINOIS
DEPARTMENT OF TRANSPORTATION

LINE DIAGRAM (LOCATION 4)			
SCALE:	SHEET	OF	SHEETS
	STA.	TO	STA.

F.A.P. RTE.	SECTION	COUNTY	TOTAL SHEETS	SHEET NO.
VAR	D4 CRACK & JOINT SEALING	VARIOUS	23	13
			CONTRACT NO. 68H26	
		ILLINOIS	FED. AID PROJECT	

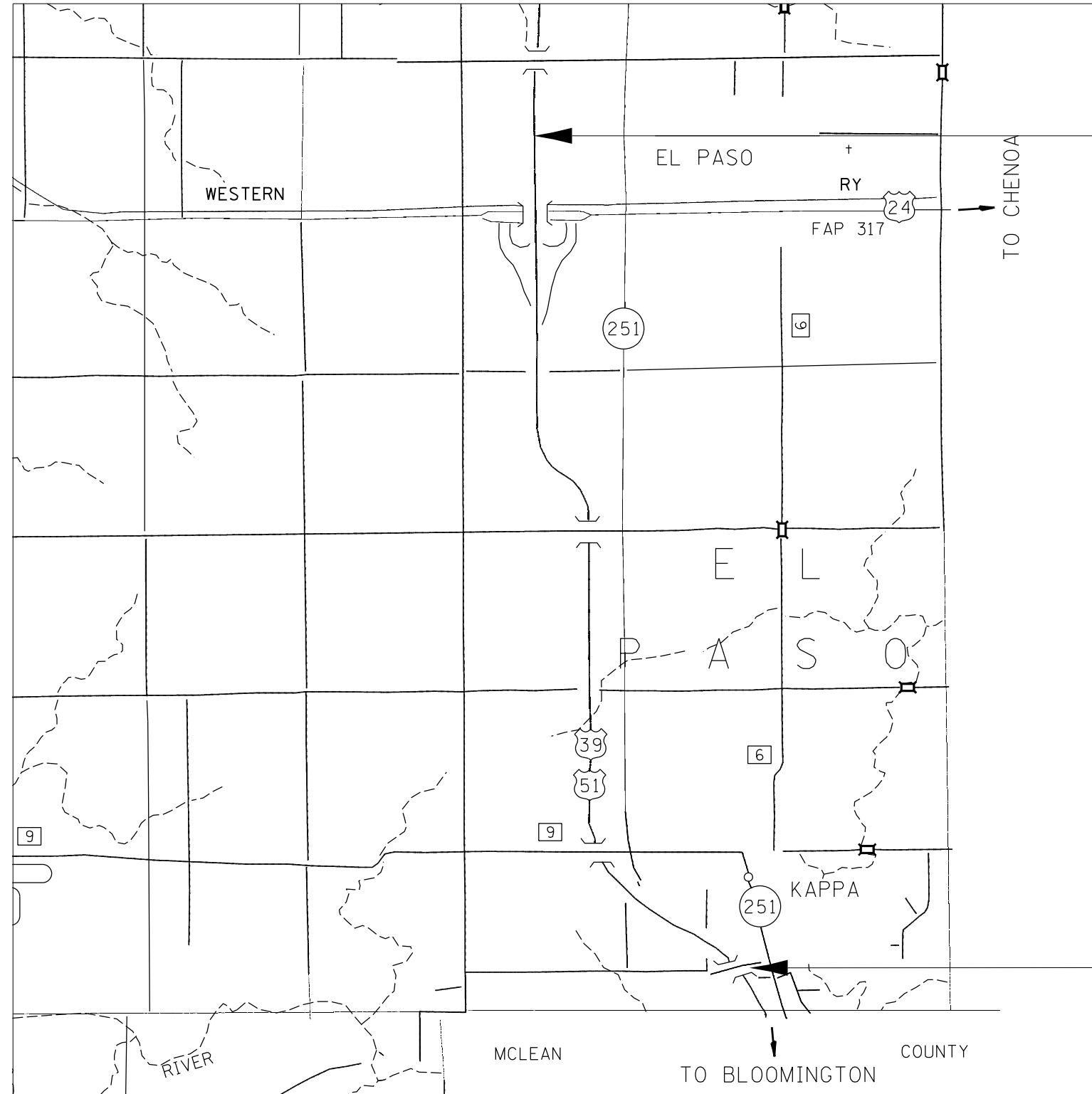

**PROJECT ENDS
STA. 461 + 00**

**PROJECT BEGINS
NB STA. 555 + 26
SB STA. 555 + 56**

MODEL: Default
 FILE NAME: \\s:\project\aw\bea\paw.com\PIV\DOT\Documents\DOT\offices\Director_d\project\ID4_68H26\CADD\DATA\CADD\sheet68H26

USER NAME = Brian,Bouris	DESIGNED -	REVISED -
	DRAWN -	REVISED -
PLOT SCALE = 100,0000' / in.	CHECKED -	REVISED -
PLOT DATE = 2/2/2024	DATE -	REVISED -

**STATE OF ILLINOIS
DEPARTMENT OF TRANSPORTATION**

LOCATION 5 MAP

SCALE: SHEET OF SHEETS STA. TO STA.

F.A.P. RTE.	SECTION	COUNTY	TOTAL SHEETS	SHEET NO.
VAR	D4 CRACK & JOINT SEALING	VARIOUS	23	14
			CONTRACT NO. 68H26	
		ILLINOIS	FED. AID PROJECT	



BRIDGE OMISSION
 I-39 OVER US 24 AND TP&W RR
 NB SN 102-0059
 STA. 448+23 TO STA. 452+71
 SB SN 102-0058
 STA. 448+23 TO STA. 452+71

CH 9 OVER I-39
 SN 102-0061

STATION EQUATION
 STA. 821+27 BK.
 STA. 417+00 AH.

I-39 OVER MACKINAW RIVER
 NB / SB SN 057-0203
 STA. 551+11 TO STA. 555+41

RAMP D
 RAMP A
 RAMP B
 RAMP C

I-39



TP&W RR

TR 165 OVER I-39
 SN 102-0057

PROJECT ENDS
 STA. 461+00

TR 207 OVER I-39
 SN 102-0060

TR 229 OVER I-39
 SN 102-0062



PROJECT BEGINS
 NB STA. 555+26
 SB STA. 555+56

MODEL: Default
 FILE: \\mattc:\pub\illdot\paw\bea\paw.com\PI\WIDOT\Documents\1001\offices\Dir\rdet_4\project\104_68H26\CADD\DATA\CAD\Sheet68H26

USER NAME = Brian,Bouris	DESIGNED -	REVISED -
	DRAWN -	REVISED -
PLOT SCALE = 100,0000' / in.	CHECKED -	REVISED -
PLOT DATE = 2/2/2024	DATE -	REVISED -

STATE OF ILLINOIS
 DEPARTMENT OF TRANSPORTATION

LINE DIAGRAM (LOCATION 5)

SCALE: SHEET OF SHEETS STA. TO STA.

F.A.P. RTE.	SECTION	COUNTY	TOTAL SHEETS	SHEET NO.
VAR	D4 CRACK & JOINT SEALING	VARIOUS	23	15
			CONTRACT NO. 68H26	
		ILLINOIS	FED. AID PROJECT	

LOCATION 1

POLYUREA PAVEMENT MARKING TYPE II						
Location	Length	Line 4" White / Yellow		SKIP Dash 6" White		8"
		Foot	Foot	Foot	Foot	
WARREN COUNTY						
Eastbound US 34						
541+50.00	TO	712+50.00	17100	34200	4275	
Station Equation 712+50 (Bk) = 710+00 (Ah)						
710+00	TO	781+22	7122	14244	1781	
Westbound US 34						
541+50.00	TO	712+50.00	17100	34200	4275	
Station Equation 712+50 (Bk) = 710+00 (Ah)						
710+00	TO	781+22	7122	14244	1781	
140th ST Ramps						
Ramp A			2200	4400		494
Ramp B			2100	4200		278
Ramp C			2200	4400		546
Ramp D			2200	4400		310
WARREN COUNTY SUBTOTAL (RURAL)			114288	12112	1628	
KNOX COUNTY						
Eastbound US 34						
781+22.00	TO	898+97.00	11775	23550	2944	
EBL - Station Equation 898+97 = Sta. 898+55 (Bk) = Sta. 333+50 (Ah)						
333+50	TO	343+65	1015	2030	254	
EBL - Station Equation 343+65 (BK) = Sta. 344+67 (Ah)						
344+67	TO	364+00	1933	3866	483	
Westbound US 34						
781+22.00	TO	898+97.00	11775	23550	2944	
WBL - Station Equation 898+97 = Sta. 898+55 (Bk) = Sta. 333+50 (Ah)						
333+50	TO	343+65	1015	2030	254	
WBL - Station Equation 343+65 (BK) = Sta. 344+67 (Ah)						
344+67	TO	364+00	1933	3866	483	
IL 164 - MAIN ST.						
Ramp C			2550	5100		298
Ramp D			2100	4200		688
KNOX COUNTY SUBTOTAL (URBAN)			68192	7362	986	
GRAND TOTAL			182480	19474	2614	

*PROPOSED PAVEMENT MARKINGS SHALL BE IN THE SAME LOCATION AS EXISTING MARKINGS

MODEL: Default
FILE NAME: p:\ultra-pw-bentley.com\P\INDOT\Documents\DOT Office\District 4\Project\ID_68H26\CADD\Drawings\CAD\Sheets\68H26

USER NAME = Brian.Bouris	DESIGNED -	REVISED -
	DRAWN -	REVISED -
PLOT SCALE = 100,0000' / in.	CHECKED -	REVISED -
PLOT DATE = 2/2/2024	DATE -	REVISED -

STATE OF ILLINOIS
DEPARTMENT OF TRANSPORTATION

SCHEDULE OF QUANTITIES

SCALE: SHEET OF SHEETS STA. TO STA.

F.A.P. RTE.	SECTION	COUNTY	TOTAL SHEETS	SHEET NO.
VAR	D4 CRACK & JOINT SEALING	VARIOUS	23	16
			CONTRACT NO. 68H26	
		ILLINOIS	FED. AID PROJECT	

LOCATION 2										
LOCATION				HOT SPRAY THERMOPLASTIC PAVEMENT MARKING - LINE 4"				HOT SPRAY THERMOPLASTIC PAVEMENT MARKING - LINE 6"	HOT SPRAY THERMOPLASTIC PAVEMENT MARKING - LINE 8"	
IL 40				FOOT				FOOT	FOOT	
				SOLID WHITE	SOLID YELLOW	DOUBLE SOLID YELLOW	SKIP DASH YELLOW		SOLID WHITE	DOTTED WHITE
STA	154+75	TO	167+00	2640.0	2566.0		160.0	600.0	1095.0	45.0
STA	167+00	TO	183+21	3289.0	3237.0			820.0	1571.0	246.0
NHPP SUBTOTAL				11892.0				1420.0	2957.0	
STA	188+06	TO	202+50	2895.0	2451.0	924.0		720.0	1915.0	57.0
STBG SUBTOTAL				6270.0				720.0	1972.0	
TOTALS				18,162				2,140	4,929	

*PROPOSED PAVEMENT MARKINGS SHALL BE IN THE SAME LOCATION AS EXISTING MARKINGS

MODEL: Default
 FILE NAME: p:\project-pw-bentley.com\PW\DOT\Documents\DOT Office\Dir\rdet_4\Project\ID4_68H26\CADD\Draws\CAD\Sheets\68H26

USER NAME = Brian.Bouris	DESIGNED -	REVISED -	STATE OF ILLINOIS DEPARTMENT OF TRANSPORTATION	SCHEDULE OF QUANTITIES				F.A.P. RTE.	SECTION	COUNTY	TOTAL SHEETS	SHEET NO.
PLOT SCALE = 100,0000' / in.	DRAWN -	REVISED -						VAR	D4 CRACK & JOINT SEALING	VARIOUS	23	17
PLOT DATE = 2/2/2024	CHECKED -	REVISED -		SCALE:	SHEET	OF	SHEETS	STA.	TO	STA.	CONTRACT NO. 68H26	
	DATE -	REVISED -									ILLINOIS FED. AID PROJECT	

LOCATION 4								
MODIFIED URETHANE PAVEMENT MARKING LINE - 4"								
LOCATION			LENGTH	EDGE	NPZ	SKIP DASH	NPZ	EDGE
IL 117				W	Y	Y	Y	W
STA		STA	FT	FOOT	FOOT	FOOT	FOOT	FOOT
128+90	TO	126+83	207			52	207	
126+72	TO	124+30	242		242	61		
124+30	TO	106+23	1807			452		
14+02	TO	22+00	798	798		200	798	798
22+00	TO	24+62	262	262	262		262	262
24+62	TO	32+63	801	801	801	200		801
32+63	TO	35+00	237	237		59		237
35+00	TO	44+50	950	950		238	950	950
44+50	TO	46+50	200	200	200		200	200
46+50	TO	59+45	1295	1295	1295	324		1295
SUB-TOTALS (URBAN)				4543	2800	1584	2417	4543
				15887				
59+45	TO	60+42	97	97		24		97
60+42	TO	70+31	989	989		247	989	989
70+31	TO	87+39	1708	1708	1708		1708	1708
87+39	TO	96+69	930	930	930	233		930
96+69	TO	105+72	903	903		226		903
105+72	TO	113+45	773	773		193	773	773
113+45	TO	115+77	232	232		58		232
115+77	TO	123+33	756	756	756	189		756
123+33	TO	134+68	1135	1135		284		1135
134+68	TO	150+54	1586	1586		397	1586	1586
150+54	TO	153+12	258	258		65		258
153+12	TO	160+12	700	700	700	175		700
160+12	TO	163+30	318	318		80		318
163+30	TO	173+14	984	984		246	984	984
173+14	TO	174+14	100	100		25		100
174+14	TO	182+75	861	861	861	215		861
182+75	TO	241+53	5878	5878		1470		5878
SUB-TOTALS (RURAL)				18208	4955	4125	6040	18208
				51536				

*PROPOSED PAVEMENT MARKINGS SHALL BE IN THE SAME LOCATION AS EXISTING MARKINGS

MODEL: Default
 FILE: \\mfrs-pw-beadley.com\PW\DOT\Documents\DOT Office\Dir\rdt_4\Project\104_68H26\CADD\Draws\CAD\Draws\68H26

USER NAME = Brian.Bouris	DESIGNED -	REVISED -	STATE OF ILLINOIS DEPARTMENT OF TRANSPORTATION	SCHEDULE OF QUANTITIES				F.A.P. RTE.	SECTION	COUNTY	TOTAL SHEETS	SHEET NO.
PLOT SCALE = 100,0000' / in.	DRAWN -	REVISED -						VAR	D4 CRACK & JOINT SEALING	VARIOUS	23	18
PLOT DATE = 2/2/2024	CHECKED -	REVISED -		SCALE:	SHEET	OF	SHEETS	STA.	TO	STA.	CONTRACT NO. 68H26	
	DATE -	REVISED -		ILLINOIS FED. AID PROJECT								

LOCATION 5						
HOT-SPRAY THERMOPLASTIC PAVEMENT MARKING - LINE			4"	6"	8"	
LOCATION			WHITE	YELLOW	WHITE	WHITE
	TO	STATION	FOOT	FOOT	FOOT	FOOT
I-39 NORTHBOUND						
555+26	TO	821+27	26601	26601	8867	
821+27 BK = 417+00 AH						
417+00	TO	426+04	904	904	301	
426+04	TO	428+75		271	90	
428+75	TO	432+67		392	131	
432+67	TO	444+92	1225	1225	408	
444+92	TO	448+74		382	127	
448+74	TO	456+61		787	262	
456+61	TO	499+00	4239	4239	1413	
SUBTOTAL			67770	11600	0	
I-39 SOUTHBOUND						
555+56	TO	821+27	26571	26571	8857	
821+27 BK = 417+00 AH						
417+00	TO	418+91	191	191	64	
418+91	TO	426+59		768	256	
426+59	TO	430+58		399	133	
430+58	TO	444+48	1390	1390	463	
444+48	TO	448+18		370	123	
448+18	TO	451+09		291	97	
451+09	TO	499+00	4791	4791	1597	
SUBTOTAL			67714	11590	0	
I-39 / US 24 INTERCHANGE						
RAMP A						
0+00	TO	2+91	291			97
2+91	TO	6+61	370			740
6+61	TO	26+35	1974	1974		
INTERSECTION WITH US 24						249
SUBTOTAL			4609	0	1086	
RAMP B						
INTERSECTION WITH US 24						
0+00	TO	13+89	1389	1389		
13+89	TO	17+71	382			764
17+71	TO	25+58	787			262
SUBTOTAL			3947	0	1026	
RAMP C						
0+00	TO	2+71	271			90
2+71	TO	6+63	392			784
6+63	TO	25+28	1865	1865		
INTERSECTION WITH US 24						249
SUBTOTAL			4393	0	1123	
RAMP D						
INTERSECTION WITH US 24						
0+00	TO	21+26	2126	2126		
21+26	TO	25+25	399			798
25+25	TO	32+93	768			256
SUBTOTAL			5419	0	1054	
TOTAL			153852	23191	4290	

*PROPOSED PAVEMENT MARKINGS SHALL BE IN THE SAME LOCATION AS EXISTING MARKINGS

MODEL: Default
 FILE NAME: p:\project\paw\benefit.com\p\p\DOT\Documents\DOT\offices\Dir\dir.ctb\68H26\CADD\DATA\CAD\Sheet68H26

USER NAME = Brian.Bouris	DESIGNED -	REVISED -
	DRAWN -	REVISED -
PLOT SCALE = 100,0000' / in.	CHECKED -	REVISED -
PLOT DATE = 2/2/2024	DATE -	REVISED -

**STATE OF ILLINOIS
DEPARTMENT OF TRANSPORTATION**

SCHEDULE OF QUANTITIES

SCALE: SHEET OF SHEETS STA. TO STA.

F.A.P. RTE.	SECTION	COUNTY	TOTAL SHEETS	SHEET NO.
VAR	D4 CRACK & JOINT SEALING	VARIOUS	23	19
			CONTRACT NO. 68H26	
		ILLINOIS	FED. AID PROJECT	

MODEL: Default
 FILE: \\murf\p\subject-pw-beaufay.com\P\INDOT\Documents\INDOT_Offices\Director_4\Project\ID_68H26\CADD\Drawn\CAD\Sheet68H26

CRACK ROUTING AND FILLING			
	ROUTE	LOCATION DESCRIPTION	POUND
WARREN COUNTY			
	US 34	LOCATION 1 - FROM 140th ST. TO KNOX COUNTY LINE (INCLUDES RAMPS AT 140th ST)	61467
KNOX COUNTY			
	US 34	LOCATION 1 - FROM KNOX COUNTY LINE TO IL 164 (INCLUDES IL 164 RAMPS C & D)	27763
PEORIA COUNTY			
	IL 40	LOCATION 2 - FROM TIMBER LN TO IL 6	8454
	IL 40	LOCATION 2 - FROM IL 6 TO RAVINWOODS RD	3622
WOODFORD COUNTY			
	IL 117	LOCATION 3 - FROM I-74 TO US 150 (INCLUDES I-74 RAMPS)	11036
	IL 117	LOCATION 4 - FROM MILL ST TO 0.3 MILES NORTH OF EDGEWOOD RD	3608
	IL 117	LOCATION 4 - FROM 0.3 MILES N OF EDGEWOOD RD TO IL 116	14430
	I-39	LOCATION 5 - FROM MCLEAN COUNTY LINE TO US 24 (INCLUDES RAMPS AT US 24)	90875

MOBILIZATION	
LOCATION	LUMP SUM
JOBSITE	1
TOTAL	1

TRAFFIC CONTROL AND PROTECTION STANDARD (SPECIAL)	
LOCATION	LUMP SUM
JOBSITE	1
TOTAL	1

CHANGEABLE MESSAGE SIGN	
JOBSITE	CAL DAY
2 SIGNS 7 DAYS EACH (PER LOCATION)	70
TOTAL	70

TRAFFIC CONTROL AND PROTECTION STANDARD 701306	
LOCATION	LUMP SUM
JOBSITE	1
TOTAL	1

USER NAME = Brian.Bouris	DESIGNED -	REVISED -
	DRAWN -	REVISED -
PLOT SCALE = 100,0000 ' / in.	CHECKED -	REVISED -
PLOT DATE = 2/2/2024	DATE -	REVISED -

**STATE OF ILLINOIS
 DEPARTMENT OF TRANSPORTATION**

SCHEDULE OF QUANTITIES			
SCALE:	SHEET	OF SHEETS	STA. TO STA.

F.A.P. RTE.	SECTION	COUNTY	TOTAL SHEETS	SHEET NO.
VAR	D4 CRACK & JOINT SEALING	VARIOUS	23	20
			CONTRACT NO. 68H26	
		ILLINOIS FED. AID PROJECT		

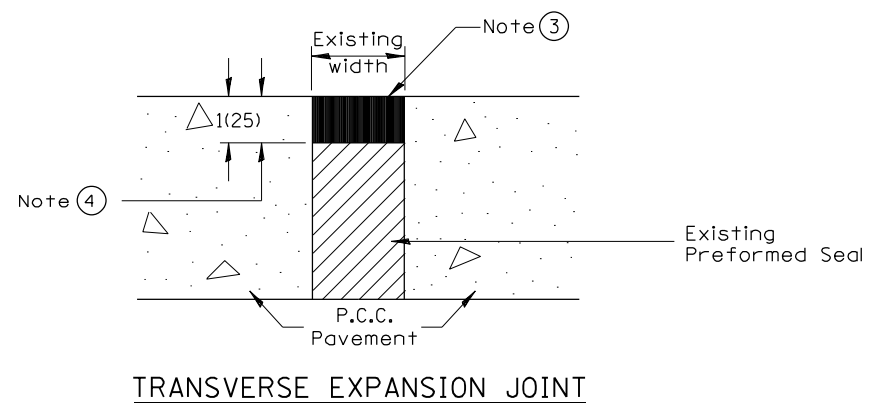
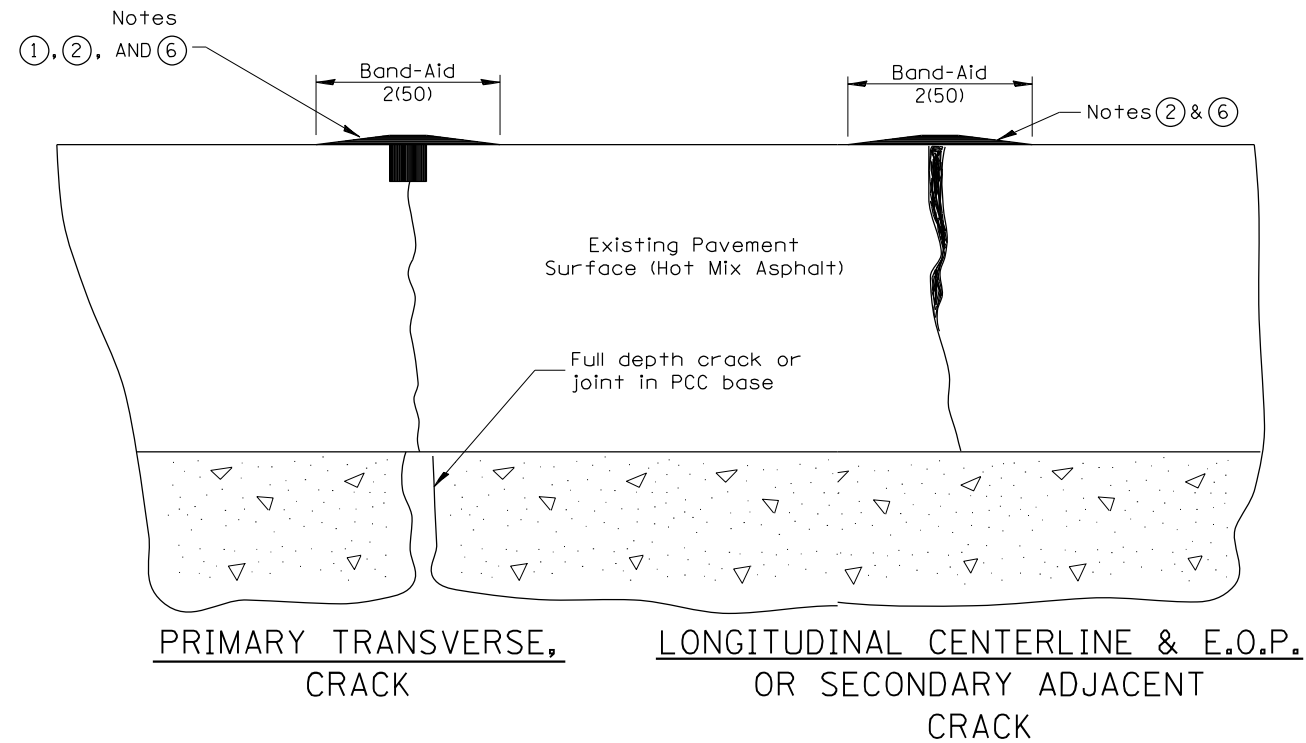

NOTES

- ① Route or saw to $\frac{3}{4}$ (20) wide by $\frac{3}{4}$ (20) deep; (1:1 ratio).
- ② Overfill with sealant; squeegee to provide 2 (50) wide flush "band-aid" effect; feather edges flush.
- ③ Seal flush without "band-aid" effect.
- ④ Route to 1(25) depth; clean and reface walls.
- ⑤ Crack and Joint Sealing shall conform to Section 451 and 452
- ⑥ The "Band Aid" width shall be reduced or eliminated in areas adjacent to existing pavement markings as directed by the Engineer.

All dimensions are in inches (millimeters) unless otherwise noted.

01-01-97	RENUM. C-36.01, NEW REVISE BOX	T.P.	01-05-21	REVISED	R.D.
05-01-97	REVISED	E.T.			
10-16-06	REVISED TO 2007 SPEC.	M.A.			
01-01-17	REVISED	R.D.			

**STATE OF ILLINOIS
DEPARTMENT OF TRANSPORTATION**

CRACK AND JOINT SEALING

NOT TO SCALE

CADD STD. 452001-D4

F.A.P. RTE.	SECTION	COUNTY	TOTAL SHEETS	SHEET NO.
VAR D4 CRACK & JOINT SEALING		VARIOUS	23	21
FED. ROAD DIST. NO. ILLINOIS FED. AID PROJECT			CONTRACT NO. 68H26	

DESIGNER NOTES:
1. Include State Standard 780001 (Typical Pavement Markings)

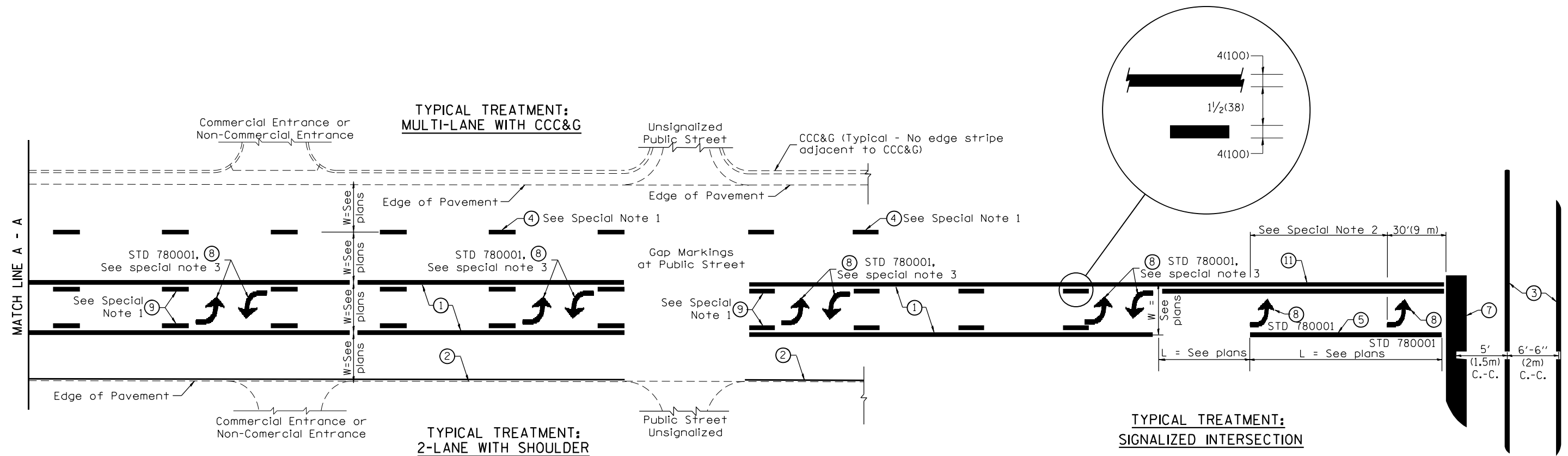

FLUSH PAVED MEDIAN: TWO-WAY LEFT TURN LANE WITH ONE-WAY LEFT TURN LANE AT SIGNALIZED INTERSECTION

TYPICAL PAVEMENT MARKING LEGEND

(Note: This is a District Standard Legend. Some elements may not apply to specific project.)

- ① 4(100) Solid (Yellow)
- ② 4(100) Solid (White)
- ③ 2-6(150) Crosswalk @ 6'-6" (2m)min C.-C. (White)
2-8(200) Crosswalk @ 6'-6" (2m)min C.-C. (White) (When traffic signals are present.)
- ④ 6(150) Skip-Dash (White) (See Special Note 1)
- ⑤ 8(200) Solid (White)
- ⑥ 12(300) Diagonal (White) (Item ⑥ is shown on Std. 780001)
- ⑦ 24(600) Stop Bar (White)
- ⑧ Letters & Arrows (See Std. 780001 and Special Notes 2 & 3)
- ⑨ 4(100) Skip-Dash (Yellow) (See Special Note 1)
- ⑩ 12(300) Diagonal (Yellow) (See Table A) (See Table A)
- ⑪ 4(100) Double Solid (Yellow) (See Table A)

SPECIAL NOTES

1. Skip-Dash markings will be centered between both ends of city blocks and shall be placed in alignment transversely across the pavement.
2. The following shall apply to arrows located in one-way left turn lanes:
 - A. A minimum of two (2) arrows is required.
 - B. The maximum spacing between arrows is 80' (24 m).
 - C. Arrows shall be evenly spaced if three (3) or more are required.
3. The following shall apply to arrow pairs located in two-way left turn lanes:
 - A. A minimum of two (2) arrow pairs is required.
 - B. The maximum spacing between arrow pairs is 200' (61 m).
 - C. Arrow pairs shall be evenly spaced if three (3) or more are required.
 - D. The spacing between Bi Directional Left Turn Arrows is 33' (10 m).

GENERAL NOTES

1. Refer to State Standard 780001 for additional Pavement Markings including letters & arrows.
2. See Plans for Pavement Markings adjacent to curbed islands and medians, and through lane reductions.
3. Refer to Article 780.13 for letter, number and symbol areas (sq. ft.)
4. Areas are grooved 1" beyond each edge for the following symbols:
 - Through Arrow= 14.8 sq. ft.
 - Large Left or Right Arrow= 21.9 sq. ft.
 - 2 Arrow Combination Left (or Right) and Through= 34.9 sq. ft.
 - Wrong Way Arrow= 29.5 sq. ft.
 - Railroad Crossing Symbol= 69.8 sq. ft.
 (For further information, refer to BDE Special Provision: Grooving for Recessed Pavement Markings)

01-01-97	RENUM. F-8.03, NEW REVISION BOX	T.P.	10-16-06	REVISED TO 2007 SPEC.	
02-07-97	ADD BI DIRECTIONAL DIMENSION	J.A.	2/29/16	ADDED GROOVING AREAS	R.D.
10-97	CORRECT BI DIRECTIONAL DIMENSION	J.A.	07-16-19	SPELLING CORRECTIONS	R.D.
08-02	ADD CROSSWALK DMNS. WITH T.S.	M.A.			

**STATE OF ILLINOIS
DEPARTMENT OF TRANSPORTATION**

NOT TO SCALE

TYPICAL PAVEMENT MARKINGS

SHT. 1 OF 2
CADD STD. 780001-D4

F.A.P. RTE.	SECTION	COUNTY	TOTAL SHEETS	SHEET NO.
VAR D4 CRACK & JOINT SEALING		VARIOUS	23	22
FED. ROAD DIST. NO. ILLINOIS FED. AID PROJECT			CONTRACT NO. 68H26	

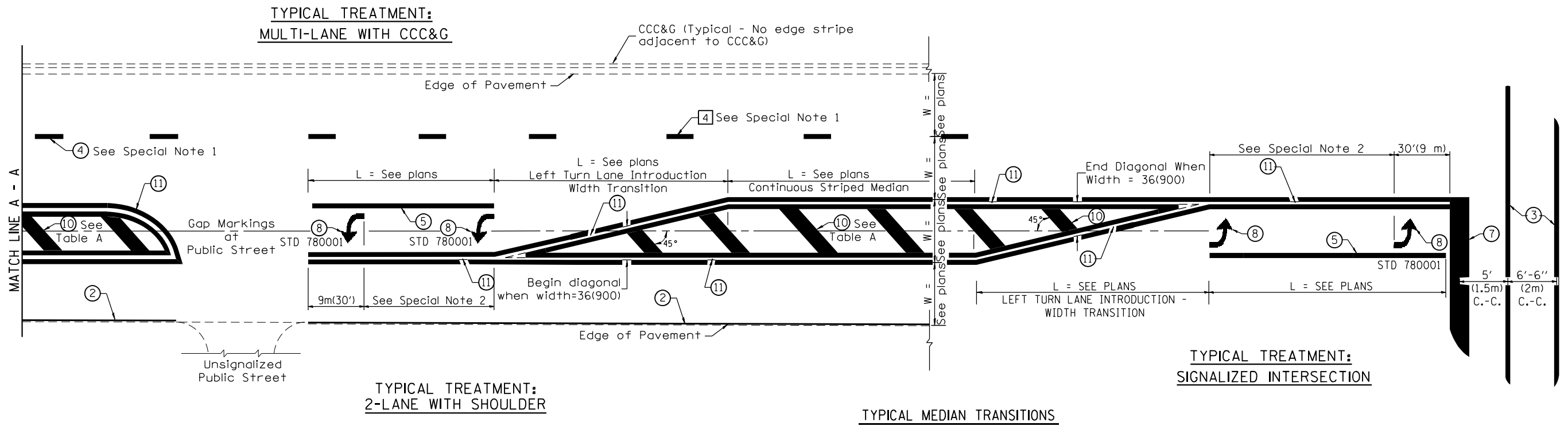

FLUSH PAVED MEDIAN: RESTRICTED LEFT TURN LANE

TABLE A
RECOMMENDED SPACING BETWEEN DIAGONAL LINES

SPEED LIMIT RANGE	INTERSECTION CHANNELIZATION (Includes Width Transitions for Median and Left Turn Lane Introductions)	
	CONTINUOUS	
Less Than 30 mph (50 km/h)	50' (15m)	15' (5m)
30 - 45 mph (50 - 70 km/h)	75' (23m)	20' (6m)
Over 45 mph (70 km/h)	150' (46m)	30' (9m)

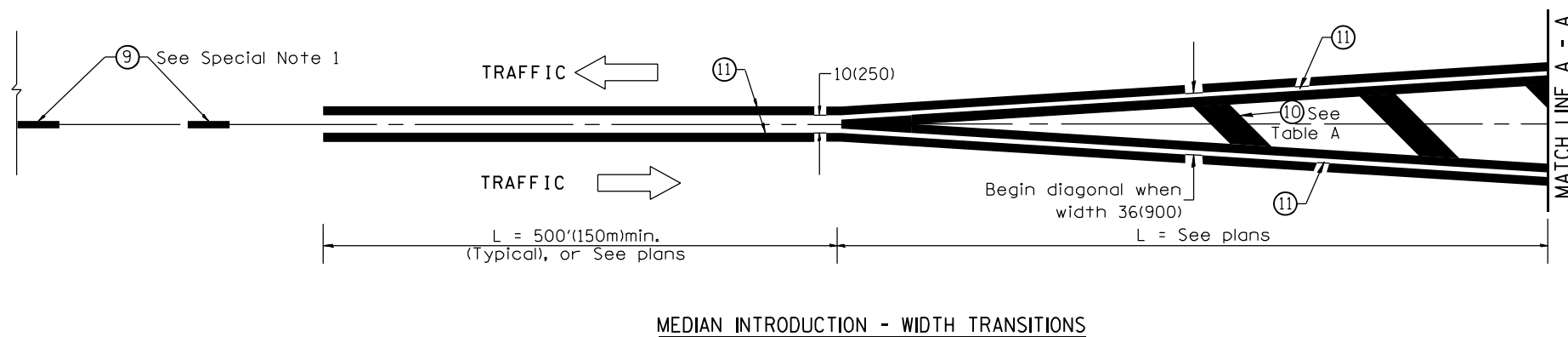

All dimensions are in inches (millimeters) unless otherwise noted.