

04-28-2023 LETTING ITEM 130

FOR INDEX OF SHEETS, SEE SHEET 2 OF 39
FOR HIGHWAY STANDARDS, SEE SHEET 2 OF 29

STATE OF ILLINOIS
DEPARTMENT OF TRANSPORTATION
**PLANS FOR PROPOSED
BRIDGE REPLACEMENT**

FAU 5560 (DIXON AVENUE OVER HOWLAND CREEK) CH 3
WHITESIDE COUNTY
COLOMA TOWNSHIP
SECTION 17-00228-00-BR
PROJECT NO. Z8AR(821)
JOB NO. C-92-043-20
CONTRACT NO. 85734

EXISTING STRUCTURE 098-3001
PROPOSED STRUCTURE 098-3079

F.A.S. R.T.E.	SECTION	COUNTY	TOTAL SHEETS	SHEET NO.
5560	17-00228-00-BR	WHITESIDE	39	01
	COLOMA TWP	ILLINOIS		STRUCTURE NO. 098-3079

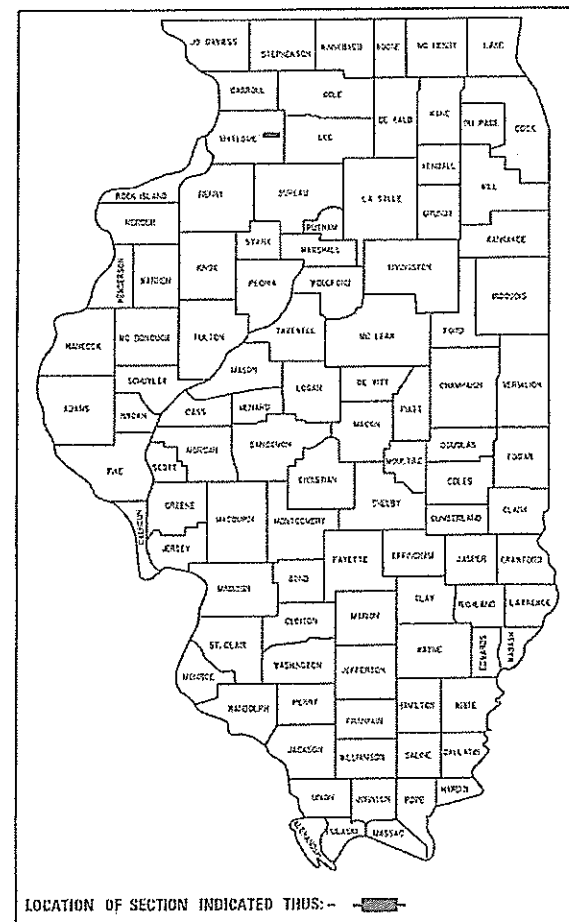

LOCATION OF SECTION INDICATED THUS: -

FUNCTIONAL CLASSIFICATION - MINOR ARTERIAL
2023 ADT = 3150
DESIGN SPEED = 40 MPH

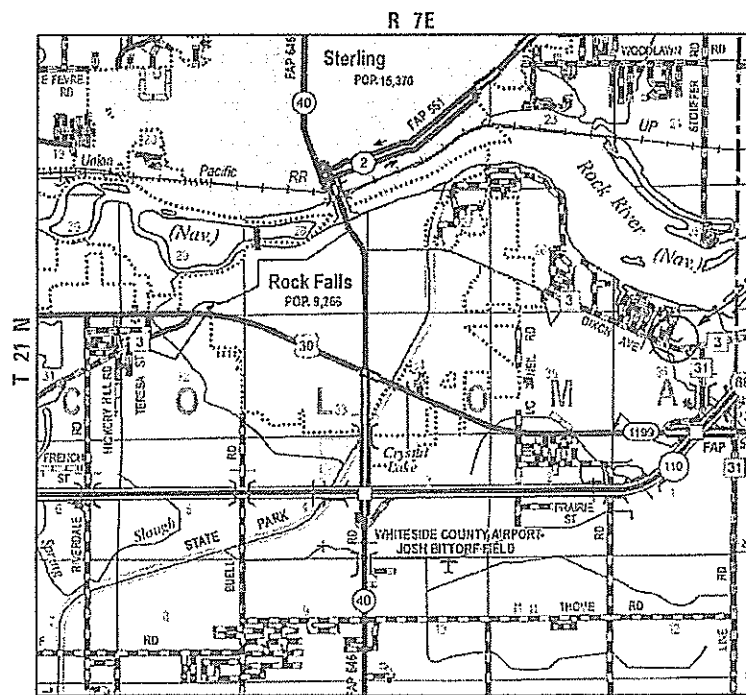

4TH PM
LOCATION MAP
TOTAL LENGTH = 641.55 FT. = 0.12 MILE
NET LENGTH = 641.55 FT. = 0.12 MILE

SECTION 17-00228-00-BR
BEGINS STATION 108+66.45
ENDS STATION 115+08.00

UTILITIES

COMMUNICATIONS:
ATT/DISTRIBUTION
G11629@ATT.COM

COMCAST
MARTHA GIERAS
224-229-5862
MARTHA_GIERAS@COMCAST.COM

ENERGY:
CITY OF ROCK FALLS ELECTRIC DEPARTMENT
DICK SIMON
815-622-1145
815-716-0120
dsimon@rockfalls61071.com

NICOR GAS
UTILITY CONSULTANT G03W
630-388-2362

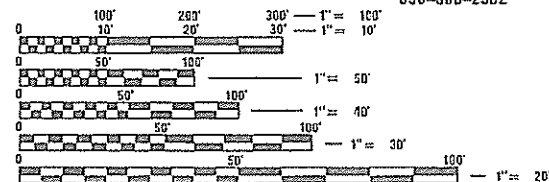

FULL SIZE PLANS HAVE BEEN PREPARED USING STANDARD ENGINEERING SCALES. REDUCED SIZED PLANS WILL NOT CONFORM TO STANDARD SCALES. IN MAKING MEASUREMENTS ON REDUCED PLANS, THE ABOVE SCALES MAY BE USED.

J.U.L.I.E.
JOINT UTILITY LOCATING INFORMATION FOR EXCAVATORS
1-800-892-0123
OR 811

HLC PROJECT NO. 7164



Anthony R. Fortin
ANTHONY R. FORTIN, P.E.
DATE 01/20/2023
LICENSE EXPIRES 11/30/2023

THE PROPOSED IMPROVEMENT CONSISTS OF REMOVAL OF EXISTING STRUCTURE AND REPLACEMENT WITH A PBFTG DECK BEAM BRIDGE ON SPILL THROUGH CONCRETE PILE BENT ABUTMENTS AND CONCRETE ENCASED PIERS. 54' CLEAR ROADWAY AND 108'-4" BACK TO BACK ABUTMENTS, MINOR CHANNEL SHAPING, OTHER MINOR COLLATERAL WORK.

CHASTAIN & ASSOCIATES LLC
CONSULTING ENGINEERS
DECATUR (317) 422-8544
SCHAUMBURG (723) 714-0459
ROCKFORD (815) 489-0050
184-001397

APPROVED *[Signature]* 2/21/23 20 23
COUNTY ENGINEER

PASSED *[Signature]* 2/28/23 20 23
DISTRICT TWO ENGINEER OF LOCAL ROADS AND STREETS

Releasing For Bid Based on Limited Review *[Signature]* 2/28/23 20 23
DEPUTY DIRECTOR OF HIGHWAYS REGION TWO ENGINEER

STATE OF ILLINOIS
DEPARTMENT OF TRANSPORTATION

INDEX OF SHEETS

01 COVER SHEET
 02 GENERAL NOTES, SUMMARY OF QUANTITIES AND RATES OF APPLICATION
 03 ROADWAY TYPICAL SECTIONS
 04-05 PLAN AND PROFILE
 06-11 STAGE CONSTRUCTION PLANS
 12 GENERAL PLAN AND ELEVATION
 13 GENERAL DATA
 14 STAGE CONSTRUCTION
 15 TEMPORARY CONSTRUCTION BARRIER
 16 SUPERSTRUCTURE
 17 SUPERSTRUCTURE DETAILS
 18-19 BRIDGE APPROACH SLAB DETAILS
 20 STEEL RAILING, TYPE CO-10
 21 STRUCTURAL STEEL
 22 STRUCTURAL STEEL DETAILS
 23 WEST ABUTMENT
 24 EAST ABUTMENT
 25 PIER DETAILS
 26 METAL SHELL PILE DETAILS
 27 BAR SPICER ASSEMBLY AND MECHANICAL SPICER DETAILS
 28 INLETS, SPECIAL (10.2)
 29-32 WORK ZONE SIGN DETAILS (34.1)
 33-36 TRAFFIC CONTROL FOR 3 LANE SECTION (37.1)
 37-39 CROSS SECTIONS

HIGHWAY STANDARDS

000001-08 STANDARD SYMBOLS, ABBREVIATIONS AND PATTERNS
 280001-07 TEMPORARY EROSION CONTROL SYSTEMS
 420406 PAVEMENT CONNECTOR (HMA) FOR BRIDGE APPROACH SLAB
 424026-03 ENTRANCE/ALLEY PEDESTRIAN CROSSING
 515001-04 NAME PLATES FOR BRIDGES
 601101-02 CONCRETE HEADWALL FOR PIPE UNDERDRAINS
 606001-08 CONCRETE CURB TYPE B AND COMBINATION CONCRETE CURE AND GUTTER
 630301-09 SHOULDER WIDENING FOR TYPE 1 (SPECIAL) GUARDRAIL TERMINALS
 631032-10 TRAFFIC BARRIER TERMINAL, TYPE 6A
 631066 TRAFFIC BARRIER TERMINAL, TYPE 14
 701321-18 LANE CLOSURE, 2L, 2W, BRIDGE REPAIR WITH BARRIER
 701601-09 URBAN LANE CLOSURE, MULTILANE, 1W OR 2W WITH NONTRAVERSABLE MEDIAN
 701611-01 URBAN HALF ROAD CLOSURE, MULTILANE, 2W WITH MOUNTABLE MEDIAN
 701431-13 LANE CLOSURE, MULTILANE, UNDIV. WITH CROSSOVER, FOR SPEEDS ≥ 45 MPH TO 55 MPH
 701901-08 TRAFFIC CONTROL DEVICES
 704001-08 TEMPORARY CONCRETE BARRIER
 725001-01 OBJECT AND TERMINAL MARKERS
 728001-01 TELESCOPING STEEL SIGN SUPPORT
 729001-01 APPLICATIONS OF TYPES A & B METAL POSTS (FOR SIGNS & MARKERS)
 780001-05 TYPICAL PAVEMENT MARKINGS
 782006-01 GUARDRAIL AND BARRIER WALL REFLECTOR MOUNTING DETAILS
 BLR 21-9 TYPICAL APPLICATION OF TRAFFIC CONTROL DEVICES FOR CONSTRUCTION ON RURAL LOCAL HIGHWAYS

GENERAL NOTES

- ALL CONSTRUCTION SHALL BE DONE IN ACCORDANCE WITH THE DETAILS IN THE PLANS, THE SPECIAL PROVISIONS INCLUDED IN THE CONTRACT DOCUMENTS, AND THE LATEST EDITION OF THE STATE OF ILLINOIS "STANDARD SPECIFICATIONS FOR ROAD AND BRIDGE CONSTRUCTION", THE " SUPPLEMENTAL SPECIFICATIONS AND RECURRING SPECIAL PROVISIONS", THE "STANDARD SPECIFICATIONS FOR TRAFFIC CONTROL ITEMS", THE "MANUAL OF UNIFORM TRAFFIC CONTROL DEVICES FOR STREETS AND HIGHWAYS", THE "MANUAL OF TEST PROCEDURES FOR MATERIALS", AND THE "STANDARD SPECIFICATIONS FOR WATER AND SEWER MAIN CONSTRUCTION IN ILLINOIS".
 - BEFORE STARTING ANY EXCAVATION, THE CONTRACTOR SHALL CALL " J.U.L.I.E." AT 1-800-892-0123 FOR FIELD LOCATION OF BURIED ELECTRIC, TELEPHONE, GAS AND OTHER FACILITIES AT LEAST 48 HOURS PRIOR TO BEGINNING CONSTRUCTION.
 - LOCATIONS OF PUBLIC OR PRIVATE UTILITIES SHOWN ON THE PLANS ARE APPROXIMATE AND THE COUNTY DOES NOT GUARANTEE THEIR ACCURACY. THE CONTRACTOR SHALL HAVE THE RESPECTIVE UTILITY COMPANIES FIELD LOCATE ALL OF THEIR FACILITIES PRIOR TO BEGINNING CONSTRUCTION. THE CONTRACTOR SHALL ALSO VERIFY THE DEPTHS OF THE EXISTING UTILITIES IF NECESSARY. ANY RELOCATION OR LOWERING OF UTILITIES SHALL BE COORDINATED BY THE CONTRACTOR IN SUCH A MANNER AS TO NOT IMPEDE PROJECT PROGRESS.
 - THE CONTRACTOR SHALL BE RESPONSIBLE FOR THE PROTECTION OF ALL UNDERGROUND OR SURFACE UTILITIES EVEN THOUGH THEY MAY NOT BE SHOWN ON THE PLANS. ANY UTILITY THAT IS DAMAGED DURING CONSTRUCTION SHALL BE REPAIRED OR REPLACED AT THE CONTRACTOR'S EXPENSE, TO THE SATISFACTION OF THE ENGINEER.
 - THE CONTRACTOR SHALL NOTIFY THE COUNTY AT LEAST 48 HOURS IN ADVANCE OF BEGINNING WORK AND COORDINATE ALL CONSTRUCTION OPERATIONS WITH THE ENGINEER.
 - THE CONTRACTOR SHALL PROTECT AND CAREFULLY PRESERVE ALL SECTION OR SUBSECTION MONUMENTS OR PROPERTY OR REFERENCE MARKERS UNTIL THE OWNER, HIS AGENT OR AN AUTHORIZED SURVEYOR HAS WITNESSED OR OTHERWISE REFERENCED THE LOCATIONS.
 - MAINTAINING DRAINAGE: IT SHALL BE THE CONTRACTOR'S RESPONSIBILITY TO MAINTAIN DRAINAGE FLOWS AT ALL TIMES DURING THE PERFORMANCE OF THE WORK. THE CONTRACTOR SHALL SUPPLY A PLAN AS A SUBMITTAL REVIEW FOR EACH LOCATION THAT WILL MAINTAIN FLOWS THAT MEET ALL LOCAL, STATE AND FEDERAL REGULATIONS AND NOT CAUSE ANY DAMAGE UPSTREAM OR TO ANY ADJACENT DRAINAGE WATERSHED. THE PLAN SHALL BE SEALED BY A REGISTERED PROFESSIONAL ENGINEER IN THE STATE OF ILLINOIS. THE PLAN MUST BE SUBMITTED AT LEAST TWO WEEKS PRIOR TO THE START OF WORK. THE COST OF MAINTAINING DRAINAGE FLOWS SHALL BE CONSIDERED AS INCLUDED IN THE CONTRACT.
 - THE CONTRACTOR SHALL NOT SCALE DIMENSIONS FROM THE CONTRACT PLANS FOR CONSTRUCTION PURPOSES. SCALES, IF SHOWN ARE FOR INFORMATION ONLY.
 - THE CONTRACTOR SHALL SUBMIT FOR APPROVAL, THE PROPOSED CONCRETE TRUCK WASHOUT LOCATION. RUNOFF FROM WASHOUT AREAS SHALL BE CONTAINED IN DESIGNATED AREAS SO THAT RUNOFF DOES NOT REACH DITCHES, STREAMS, OR DRAINAGE SYSTEMS.
 - PLAN DIMENSIONS AND DETAILS RELATIVE TO EXISTING STRUCTURES HAVE BEEN TAKEN FROM FIELD MEASUREMENTS AND AS-BUILT PLANS. IT SHALL BE THE CONTRACTOR'S RESPONSIBILITY TO VERIFY SUCH DIMENSIONS AND DETAILS IN THE FIELD AND MAKE NECESSARY APPROVED ADJUSTMENTS PRIOR TO CONSTRUCTION OR ORDERING OF THE MATERIALS.
 - ALL WORK SHALL BE COMPLETED WITHIN THE COUNTY RIGHT-OF-WAY WITH NO EQUIPMENT OR MATERIAL STORAGE ON PRIVATE PROPERTY.
 - THE CONTRACTOR'S OPERATIONS AND TEMPORARY STORAGE ACTIVITIES SHALL BE LIMITED TO THE WORK AREA AND/OR CONSTRUCTION LIMITS.
 - COORDINATE ANY REQUIRED SIGN REMOVAL WITH THE COUNTY ONE (1) WEEK PRIOR TO CONSTRUCTION.
 - NO CHANNEL GRADING OR CULVERT CONSTRUCTION ACTIVITIES WILL BE ALLOWED IN STANDING WATER OR DURING PERIODS OF HIGH FLOWS AND EXCESSIVE CHANNEL FLOW VELOCITIES.
 - SAW CUTTING SHALL BE PERFORMED AT LOCATIONS DESIGNATED ON THE PLANS, OR AS DIRECTED BY THE ENGINEER, AND SHALL BE CONSIDERED INCLUDED IN THE COST OF APPLICABLE PAY ITEMS. CLEANING AND REMOVAL OF ANY AND ALL SAW CUT DEBRIS SHALL ALSO BE INCLUDED. TRAFFIC IS TO BE MAINTAINED FOR THE DURATION OF THE PROJECT
 - THE FOLLOWING BMPs SHALL BE IMPLEMENTED TO CONTROL RESIDUAL CONCRETE, CONCRETE SEDIMENTS, AND RINSE WATER:
 A) TEMPORARY CONCRETE WASHOUT FACILITIES SHALL BE CONSTRUCTED FOR RINSING QUI CONCRETE TRUCKS. SIGNS SHALL BE INSTALLED DIRECTING CONCRETE TRUCK DRIVERS WHERE DESIGNATED WASHOUT FACILITIES ARE LOCATED.
 B) THE CONTRACTOR SHALL HAVE THE LOCATION OF TEMPORARY CONCRETE WASHOUT FACILITIES APPROVED BY THE RESIDENT ENGINEER.
 C) ALL TEMPORARY CONCRETE WASHOUT FACILITIES ARE TO BE INSPECTED BY THE CONTRACTOR AFTER EACH USE AND ALL SPILLS MUST BE REPORTED TO THE RESIDENT ENGINEER AND CLEANED UP IMMEDIATELY.
 D) CONCRETE WASTE SOLIDS/LIQUIDS SHALL BE DISPOSED OF PROPERLY.
- COMMITMENT: WETLAND IDENTIFIED ON THE PLAN IS OUTSIDE PROJECT LIMITS AND WILL BE AVOIDED.

RATES OF APPLICATION

ITEMS	RATE OF APPLICATION
AGGREGATE BASE COURSE	= 2.05 TONS/ CU YD
RIPRAP	= 1.5 TONS/ CU YD
PORTLAND CEMENT	= 8% BY WEIGHT
BITUMINOUS MATERIALS (TACK COAT)	= 0.025 LB/SQ FT
BITUMINOUS MATERIALS (PRIME COAT)	= 0.25 TO 0.50 GAL/SQ YD AT 8.2 TO 8.35 LB/GAL

SUMMARY OF QUANTITIES

85734

CODE NUMBER	CONSTRUCTION TYPE CODE:0010 PAY ITEM	Unit	Total
20200100	EARTH EXCAVATION	Cu. Yd.	797
25000200	SEEDING, CLASS 2	Acre	0.50
25000400	NITROGEN FERTILIZER NUTRIENT	Pound	28
25000500	PHOSPHORUS FERTILIZER NUTRIENT	Pound	28
25000600	POTASSIUM FERTILIZER NUTRIENT	Pound	28
25100630	EROSION CONTROL BLANKET	Sq. Yd.	1477
28000400	PERIMETER EROSION BARRIER	Foot	1119
28000510	INLET FILTERS	Each	2
28100107	STONE RIPRAP, CLASS A4	Sq. Yd.	650
28200200	FILTER FABRIC	Sq. Yd.	650
35101800	AGGREGATE BASE COURSE, TYPE B 6"	Sq. Yd.	335
35102000	AGGREGATE BASE COURSE, TYPE B 8"	Sq. Yd.	687
35102400	AGGREGATE BASE COURSE, TYPE B 12"	Sq. Yd.	119
40600275	BITUMINOUS MATERIALS (PRIME COAT)	POUND	6863
40600290	BITUMINOUS MATERIALS (TACK COAT)	POUND	467
40604050	HOT-MIX ASPHALT SURFACE COURSE, IL-9.5, MIX "C" N50	TON	420
42000070	PAVEMENT CONNECTOR (HMA) FOR BRIDGE APPROACH SLAB	SQ. YD.	111
42400100	PORTLAND CEMENT CONCRETE SIDEWALK 4 INCH	SQ. FT.	117
42400800	DETECTABLE WARNING	SQ. FT.	8
44000161	HMA SURFACE REMOVAL, 3"	SQ. YD.	2281
44000200	DRIVEWAY PAVEMENT REMOVAL	SQ. YD.	143
44000300	CURB REMOVAL	FOOT	1060
44000600	SIDEWALK REMOVAL	SQ. FT.	97
50100100	REMOVAL OF EXISTING STRUCTURES	EACH	1
50200100	STRUCTURE EXCAVATION	CU. YD.	288
50200300	COFFERDAM EXCAVATION	CU. YD.	430
50201121	COFFERDAM (TYPE 2)(LOCATION-1)	EACH	1
50201122	COFFERDAM (TYPE 2)(LOCATION-2)	EACH	1
50300225	CONCRETE STRUCTURES	CU. YD.	259
50300255	CONCRETE SUPERSTRUCTURE	CU. YD.	2.2
50300260	BRIDGE DECK GROOVING	SQ. YD.	626
50300265	SEAL COAT CONCRETE	CU. YD.	238
50301350	CONCRETE SUPERSTRUCTURE (APPROACH SLAB)	CU. YD.	157
50800205	REINFORCEMENT BARS, EPOXY COATED	POUND	84,450
50800515	BAR SPICERS	EACH	400
50900207	STEEL RAILING, TYPE CO-10	FOOT	277
51200958	FURNISHING METAL SHELL PILES 14" X 0.250"	FOOT	1415
51202305	DRIVING PILES	FOOT	1415
51203200	TEST PILE METAL SHELLS	EACH	4
51204650	PILE SHOES	EACH	42
51500100	NAME PLATES	EACH	1
52100520	ANCHOR BOLTS, 1"	EACH	108
52200010	TEMPORARY SHEET PILING	SQ. FT.	435
550A0050	STORM SEWERS, CLASS A, TYPE 1 12"	FOOT	20
58600101	GRANULAR BACKFILL FOR STRUCTURES	CU. YD.	56
59100100	GEOCOMPOSITE WALL DRAIN	SQ. YD.	90
60100060	CONCRETE HEADWALLS FOR PIPE DRAINS	EACH	4
60146304	PIPE UNDERDRAINS FOR STRUCTURES 4"	FOOT	180
60500060	REMOVING INLETS	EACH	2
60605000	COMBINATION CONCRETE CURB AND GUTTER, TYPE B-6.24	FOOT	883
63100119	TRAFFIC BARRIER TERMINAL, TYPE 14	EACH	4
63100167	TRAFFIC BARRIER TERMINAL TYPE 1 (SPECIAL) TANGENT	EACH	4
67100100	MOBILIZATION	L SUM	1
70100405	TRAFFIC CONTROL AND PROTECTION, STANDARD 701321	EACH	1
70103815	TRAFFIC CONTROL SURVEILLANCE	CAL DAY	105
70106500	TEMPORARY BRIDGE TRAFFIC SIGNALS	EACH	1
70106700	TEMPORARY RUMBLE STRIPS	EACH	2
70107005	PAVEMENT MARKING BLACKOUT TAPE, 5"	FOOT	1000
70300150	SHORT TERM PAVEMENT MARKING REMOVAL	SQ FT	4687
70307120	TEMPORARY PAVEMENT MARKING - LINE 4"- TYPE IV TAPE	FOOT	15133
70307210	TEMPORARY PAVEMENT MARKING - LINE 24"- TYPE IV TAPE	FOOT	24
70400100	TEMPORARY CONCRETE BARRIER	FOOT	810
70400125	PINNING TEMPORARY CONCRETE BARRIER	EACH	108
70400200	RELOCATE TEMPORARY CONCRETE BARRIER	FOOT	570
70600240	IMPACT ATTENUATORS, TEMPORARY (NON- REDIRECTIVE), TEST LEVEL 2	EACH	4
70600340	IMPACT ATTENUATORS, RELOCATE (NON- REDIRECTIVE), TEST LEVEL 2	EACH	2
72501000	TERMINAL MARKER-DIRECT APPLIED	EACH	4
78009004	MODIFIED URETHANE PAVEMENT MARKING - LINE 4"	FOOT	2742
X0322916	PROPOSED STORM SEWER CONNECTION TO EXISTING STORM SEWER	EACH	3
X0326806	WASHOUT BASIN	L SUM	1
X6024240	INLETS, SPECIAL	EACH	2
XX009565	ERECTING SUPERSTRUCTURE	SQ. FT.	6175
Z0004510	HOT-MIX ASPHALT DRIVEWAY PAVEMENT, 3"	SQ. YD.	119
Z0013798	CONSTRUCTION LAYOUT	L SUM	1

MODEL: Default
 FILE NAME: E:\Proj\County164\WhiteSide Co. - Dixon Ave Bridge\CADD\CADD_Civil_Electrics_S&UD\27164-SHT_Gen Notes-Exec.dgn



USER NAME = jmsdara	DESIGNED - ARF	REVISED -
PLOT SCALE = 20.0000' / 1"	DRAWN - JDM	REVISED -
PLOT DATE = 3/8/2023	CHECKED - TWO	REVISED -
	DATE - 02/15/2023	REVISED -

STATE OF ILLINOIS
 DEPARTMENT OF TRANSPORTATION

GENERAL NOTES, SUMMARY OF QUANTITIES
 AND RATES OF APPLICATION

F.A.U. RTE. 5560	SECTION 17-00228-00-BR	COUNTY WHITESIDE	TOTAL SHEETS 39	SHEET NO. 2
SCALE: SHEET OF SHEETS STA. TO STA.		PROJECT 7164 ILLINOIS FED. AID PROJECT		
		CONTRACT NO.		

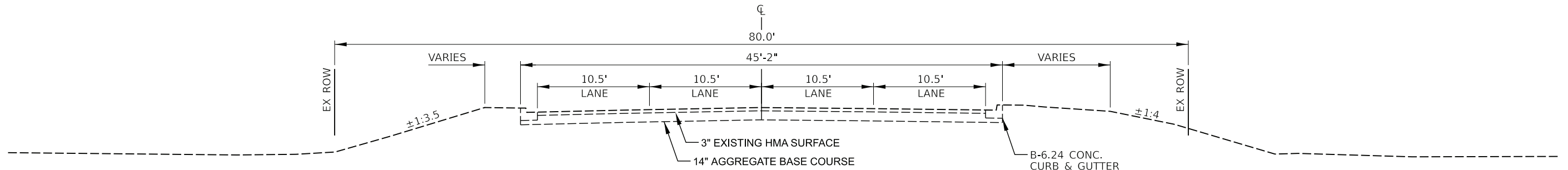

EXISTING TYPICAL SECTION

STA. 108+98.98 TO 111+58.63
STA. 112+53.31 TO 115+08.00

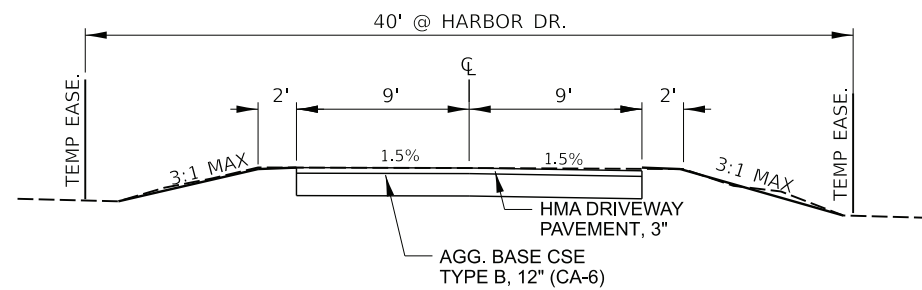

HARBOR DR./FIELD ENTRANCE DETAIL

HARBOR DRIVE STA. 110+25.83 LT.
FIELD ENTRANCE STA. 108+83.48 RT.

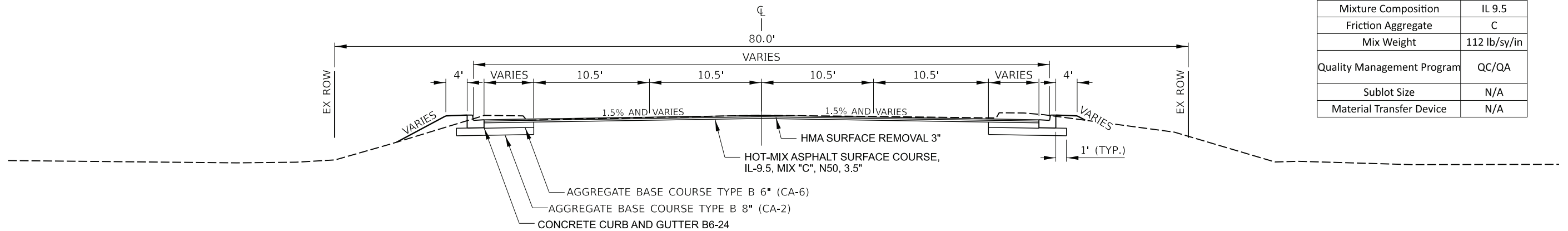

PROPOSED TYPICAL SECTION

STA. 108+98.98 TO 111+11.83
STA. 113+00.17 TO 115+08.00

Location and Mixture Use(s):	Dixon Ave Surface
PG:	PG 58-28
Design Air Voids	4.0 @ N50
Mixture Composition	IL 9.5
Friction Aggregate	C
Mix Weight	112 lb/sy/in
Quality Management Program	QC/QA
Sublot Size	N/A
Material Transfer Device	N/A

MODEL: D:\proj\85734\County7164\Whiteside Co - Dixon Ave Bridge\CADD\CADD_Civil_Erecting_Sec037164-SHT_Typ.dgn
FILE NAME: R:\proj\County7164\Whiteside Co - Dixon Ave Bridge\CADD\CADD_Civil_Erecting_Sec037164-SHT_Typ.dgn



USER NAME = jmadara	DESIGNED - ARF	REVISED -
	DRAWN - JDM	REVISED -
PLOT SCALE = 20.0000' / in.	CHECKED - TWO	REVISED -
PLOT DATE = 2/27/2023	DATE - 02/15/2023	REVISED -

**STATE OF ILLINOIS
DEPARTMENT OF TRANSPORTATION**

ROADWAY TYPICAL SECTIONS

SCALE: SHEET OF SHEETS STA. TO STA.

F.A.U. RTE.	SECTION	COUNTY	TOTAL SHEETS	SHEET NO.
5560	I7-00228-00-BR	WHITESIDE	39	3
PROJECT 7164 ILLINOIS FED. AID PROJECT			CONTRACT NO.	

LEGEND

- PERIMETER EROSION BARRIER
- PIPE & INLET PROTECTION
- STRUCTURE STA. 112+06.00 EL. 644.81

EXISTING STRUCTURE	PROPOSED STRUCTURE
098-3001	098-3079
TYPE: 3-SPAN	TYPE: 3-SPAN PBFTG
SPANS: 30-35.25-30	SPANS: 30-45-30
LENGTH: 95.3'	LENGTH: 108'-4"
WIDTH: 50.3	WIDTH: 57.0'
U.S. FLOWLINE: 642.06	U.S. FLOWLINE: 642.06
D.S. FLOWLINE: 642.06	D.S. FLOWLINE: 642.06
SKEW: 0 DEGREES	SKEW: 0 DEGREES

EX CURVE C1
 PI STA = 108+99.96
 $\Delta = 02^{\circ}05'30''$ (LT)
 $D = 00^{\circ}25'06''$
 $R = 13,695.98'$
 $T = 250.02'$
 $E = 2.28'$
 PC STA = 106+49.93
 PT STA = 111+49.93

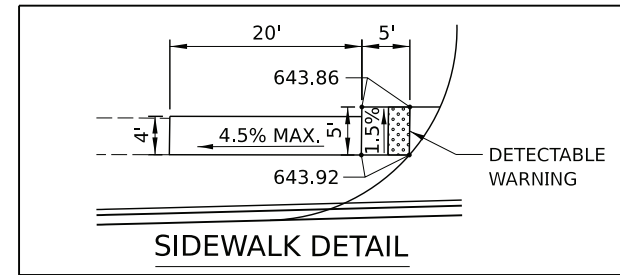

DATE	BY
DATE	BY
DATE	BY

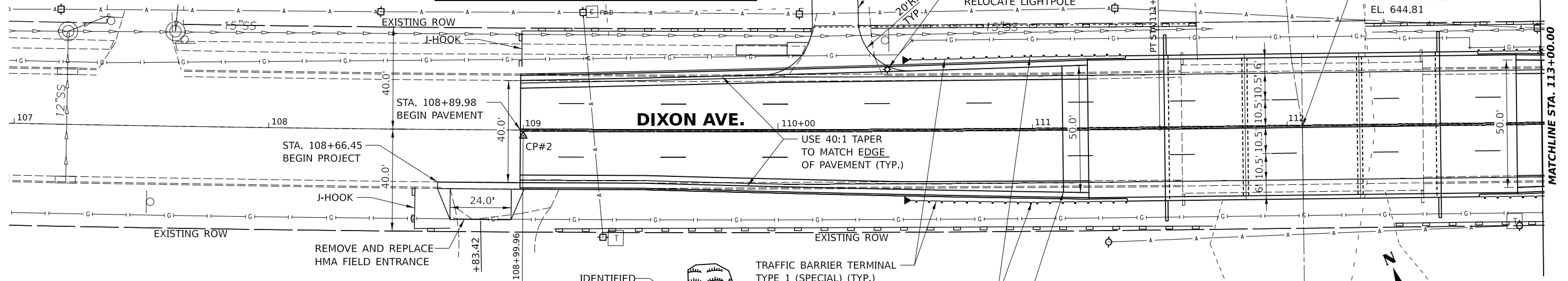

DESCRIPTION	STA./OFFSET	NORTHING	EASTING	ELEVATION
CP #1, SET PK NAIL	STA. 106+49.97, 0.0' LT	1858758.41	2439251.69	-
CP #2, SET PK NAIL	STA. 108+99.93, 2.3' RT	1858653.81	2439478.79	-
CP #3, SET PK NAIL	STA. 119+97.87, 0.0' LT	1858417.81	2440530.44	-
BM#1 - 60D NAIL IN PP	STA. 105+97, 42.3' LT	1858819.50	2439220.22	645.16
BM#2 - 60D NAIL IN PP	STA. 117+06, 40.9' LT	1858442.11	2440242.16	647.26

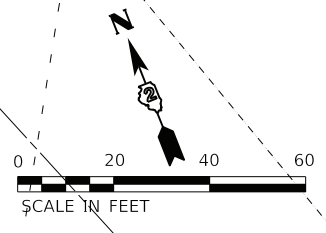
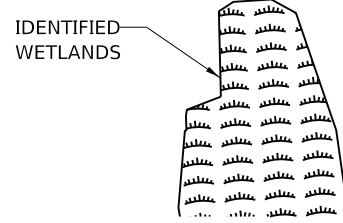

DATE	BY
DATE	BY
DATE	BY

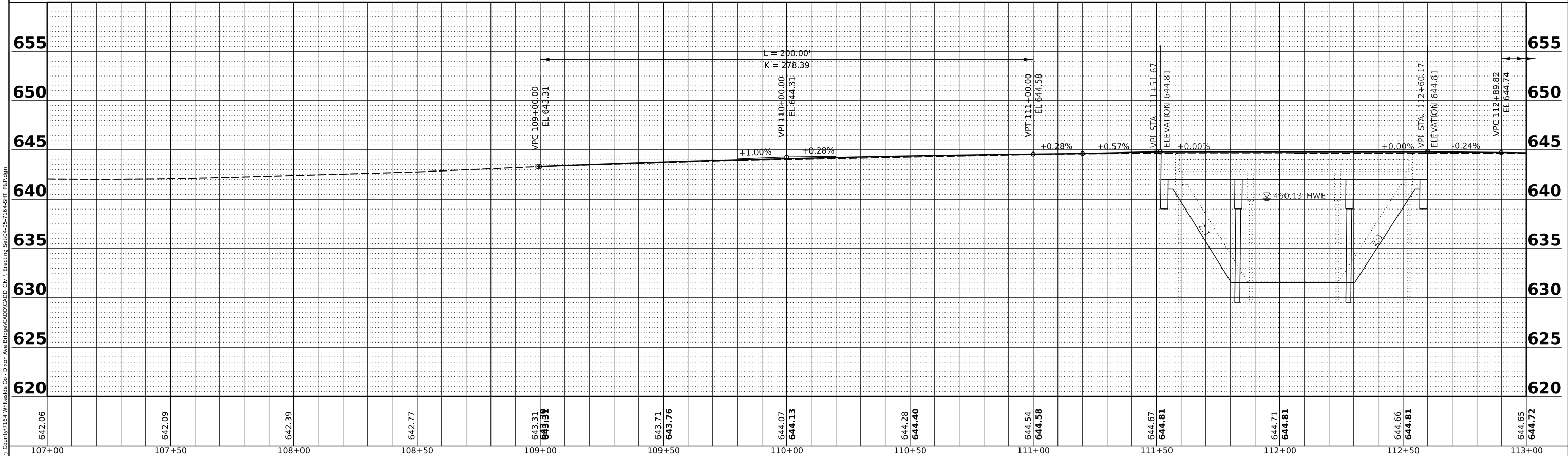

642.06	642.09	642.39	642.77	643.31	643.31	643.71	643.76	644.07	644.13	644.28	644.40	644.54	644.58	644.67	644.81	644.71	644.81	644.66	644.81	644.65	644.72	
107+00	107+50	108+00	108+50	109+00	109+50	110+00	110+50	111+00	111+50	112+00	112+50	113+00										

CHASTAIN & ASSOCIATES LLC
 CONSULTING ENGINEERS



USER NAME = jmadara	DESIGNED - ARF	REVISED -
PLOT SCALE = 0.083333' / in.	DRAWN - JDM	REVISED -
PLOT DATE = 2/15/2023	CHECKED - TWO	REVISED -
	DATE - 02/15/2023	REVISED -

STATE OF ILLINOIS
 DEPARTMENT OF TRANSPORTATION

PLAN AND PROFILE
 CH 3 (DIXON AVENUE) OVER HOWLAND CREEK
 SCALE: ##### SHEET OF SHEETS STA. TO STA.

F.A.U. RTE. 5560	SECTION 17-00228-00-BR	COUNTY WHITESIDE	TOTAL SHEETS 39	SHEET NO. 4
CONTRACT NO.				
PROJECT 7164 ILLINOIS FED. AID PROJECT				

LEGEND

-  PERIMETER EROSION BARRIER
-  PIPE & INLET PROTECTION

Superelevation: Westbound		
Station	Cross Slope	Mode
112+89.92	-1.50%	Start Point
114+40.00	-6.40%	Full Super
115+08.00	-8.00%	End Point
Superelevation: Eastbound		
Station	Cross Slope	Mode
112+89.92	-1.50%	Start Point
114+40.00	6.40%	Full Super
115+08.00	6.70%	End Point

EX CURVE C2
 PI STA = 116+75.56
 $\Delta = 33^\circ 11' 30''$ (LT)
 $D = 05^\circ 00' 00''$
 $R = 1,145.92'$
 $T = 341.52'$
 $E = 49.81'$
 PC STA = 113+34.04
 PT STA = 119+97.87

DATE	BY
DATE	BY
DATE	BY

DATE	BY
DATE	BY
DATE	BY

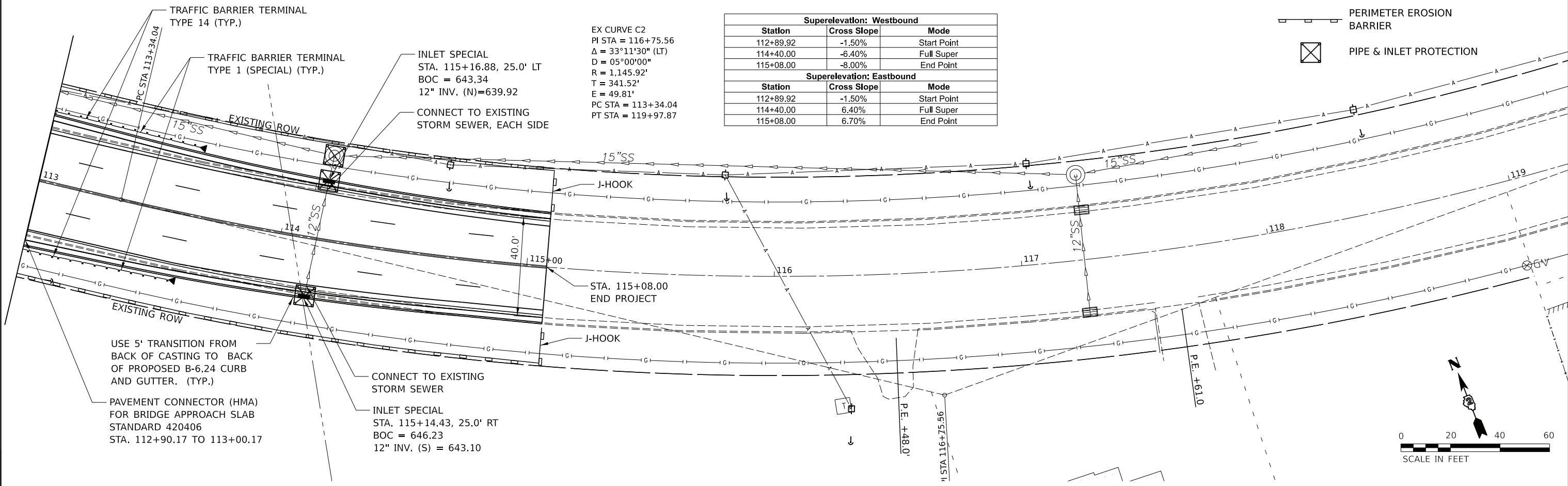

USE 5' TRANSITION FROM BACK OF CASTING TO BACK OF PROPOSED B-6.24 CURB AND GUTTER. (TYP.)

PAVEMENT CONNECTOR (HMA) FOR BRIDGE APPROACH SLAB STANDARD 420406 STA. 112+90.17 TO 113+00.17

CONNECT TO EXISTING STORM SEWER

INLET SPECIAL STA. 115+14.43, 25.0' RT BOC = 646.23 12" INV. (S) = 643.10

INLET SPECIAL STA. 115+16.88, 25.0' LT BOC = 643.34 12" INV. (N) = 639.92

CONNECT TO EXISTING STORM SEWER, EACH SIDE

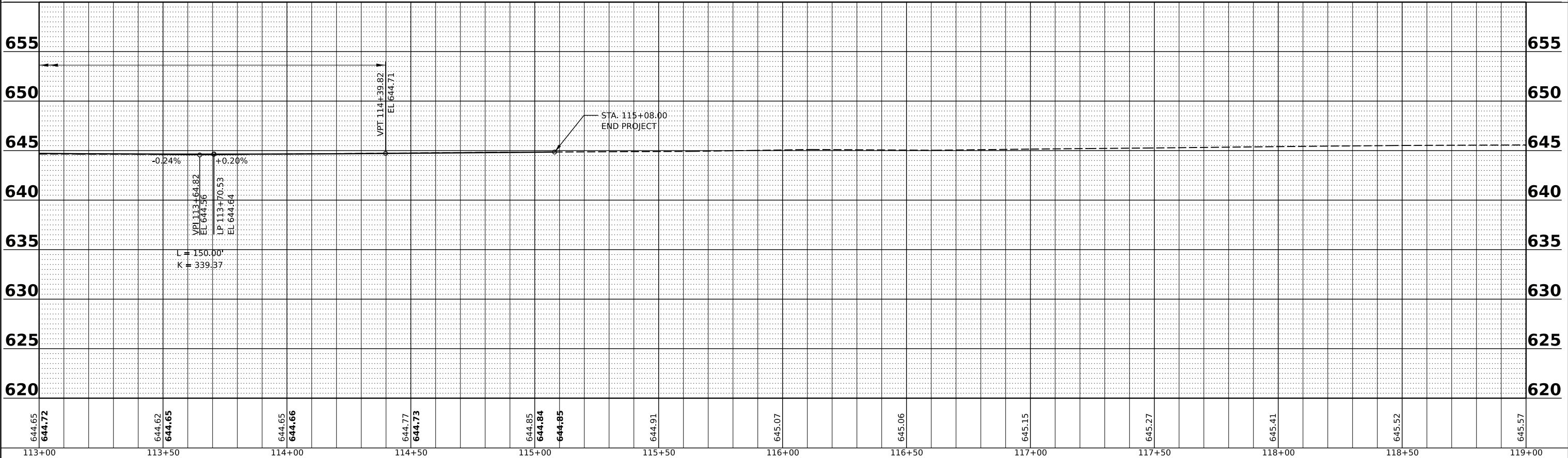
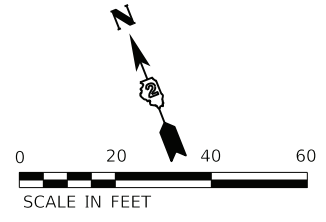

CHASTAIN & ASSOCIATES LLC
 CONSULTING ENGINEERS

USER NAME = jmadara	DESIGNED - ARF	REVISED -
PLOT SCALE = 0.083333' / in.	DRAWN - JDM	REVISED -
PLOT DATE = 2/16/2023	CHECKED - TWO	REVISED -
	DATE - 02/15/2023	REVISED -

STATE OF ILLINOIS
DEPARTMENT OF TRANSPORTATION















PLAN AND PROFILE
CH 3 (DIXON AVENUE) OVER HOWLAND CREEK

SCALE: ##### SHEET 2 OF 20 SHEETS STA. TO STA.

F.A.U. RTE.	SECTION	COUNTY	TOTAL SHEETS	SHEET NO.
5560	17-00228-00-BR	WHITESIDE	39	5
PROJECT 7164 ILLINOIS FED. AID PROJECT			CONTRACT NO.	

MODEL: EXCL - Dixon Plan-1
 FILE NAME: R:\Illinois\7164 Whiteside Co - Dixon Ave Bridge\CADD\CADD_Civil\Errecting Set\04-05-7164-SHT 2.dgn

PLAN LEGEND

-  WORK ZONE
-  TEMPORARY CONCRETE BARRIER
-  SIGN ON PERMANENT OR PORTABLE SUPPORT
-  DOUBLE VERTICAL PANEL AT 25' MIN. 1' FROM EDGE OF PAVEMENT
-  TYPE III BARRICADE WITH FLASHING MONODIRECTIONAL LIGHTS
-  IMPACT ATTENUATORS, TEMPORARY (NON-REDIRECTIVE), TEST LEVEL 2
-  DRUM AT 50' C-C SPACING IN TANGENT, 20' C-C SPACING TAPERS, AND 10' C-C SPACING IN CURVES/RADII
-  TEMPORARY LED TRAFFIC SIGNAL HEAD, NUMBER OF SECTION AND DISPLAY AS REQUIRED.
-  DETECTOR LOOPS
-  FLEXIBLE DELINEATOR
-  TRAFFIC FLOW
-  DRUM WITH STEADY BURN MONODIRECTIONAL LIGHT
-  DIRECTION INDICATOR BARRICADE WITH STEADY BURN MONODIRECTIONAL LIGHT
-  TYPE II BARRICADE, DRUM OR VERTICAL BARRICADE WITH MONODIRECTIONAL FLASHING LIGHT
-  ARROW BOARD

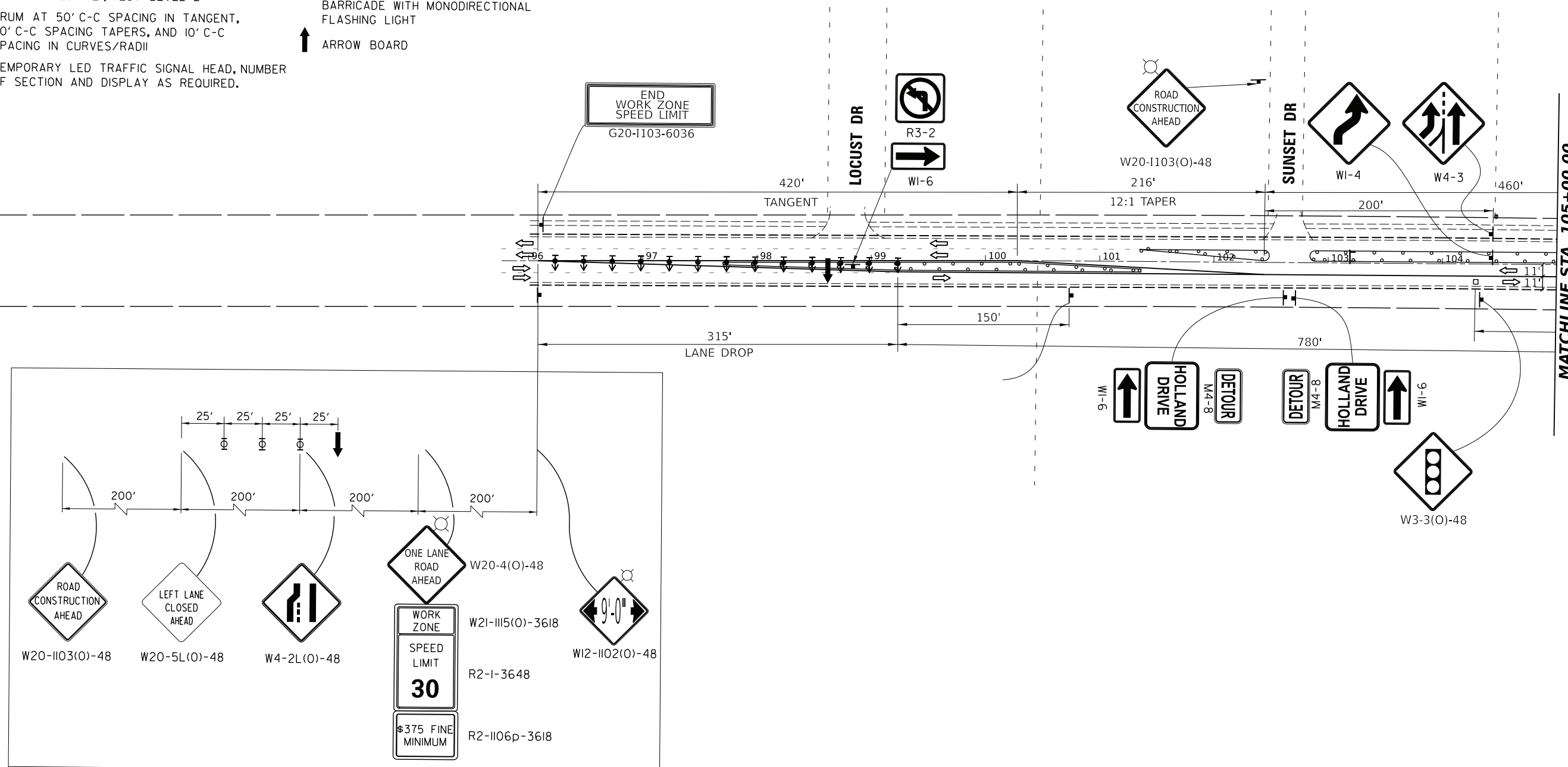

MODEL: D:\draft\CH3\County\7164\Whiteside Co - Dixon Ave Bridge\CADD\CADD_Civil\ Erecting_Sk0067164-Stage1.dgn
 FILE NAME: RCP\County\7164\Whiteside Co - Dixon Ave Bridge\CADD\CADD_Civil\ Erecting_Sk0067164-Stage1.dgn



USER NAME = jmadara	DESIGNED - ARF	REVISED -
PLOT SCALE = 50,000' / in.	DRAWN - JDM	REVISED -
PLOT DATE = 2/16/2023	CHECKED - TWO	REVISED -
	DATE - 02/15/2023	REVISED -

**STATE OF ILLINOIS
DEPARTMENT OF TRANSPORTATION**

**MAINTENANCE OF TRAFFIC - STAGE I
CH 3 (DIXON AVENUE) OVER HOWLAND CREEK**

SCALE: SHEET OF SHEETS STA. TO STA.

F.A.U. RTE.	SECTION	COUNTY	TOTAL SHEETS	SHEET NO.
5560	I7-00228-00-BR	WHITESIDE	39	6
PROJECT 7164 ILLINOIS FED. AID PROJECT			CONTRACT NO.	

PLAN LEGEND

- WORK ZONE
- TEMPORARY CONCRETE BARRIER
- SIGN ON PERMANENT OR PORTABLE SUPPORT
- DOUBLE VERTICAL PANEL AT 25' MIN. 1' FROM EDGE OF PAVEMENT
- TYPE III BARRICADE WITH FLASHING MONODIRECTIONAL LIGHTS
- IMPACT ATTENUATORS, TEMPORARY (NON-REDIRECTIVE), TEST LEVEL 2
- DRUM AT 50' C-C SPACING IN TANGENT, 20' C-C SPACING TAPERS, AND 10' C-C SPACING IN CURVES/RADI
- TEMPORARY LED TRAFFIC SIGNAL HEAD, NUMBER OF SECTION AND DISPLAY AS REQUIRED.
- ◇ DETECTOR LOOPS
- FLEXIBLE DELINEATOR
- TRAFFIC FLOW
- DRUM WITH STEADY BURN MONODIRECTIONAL LIGHT
- ⬆️ DIRECTION INDICATOR BARRICADE WITH STEADY BURN MONODIRECTIONAL LIGHT
- Ⓜ️ TYPE II BARRICADE, DRUM OR VERTICAL BARRICADE WITH MONODIRECTIONAL FLASHING LIGHT
- ↑ ARROW BOARD

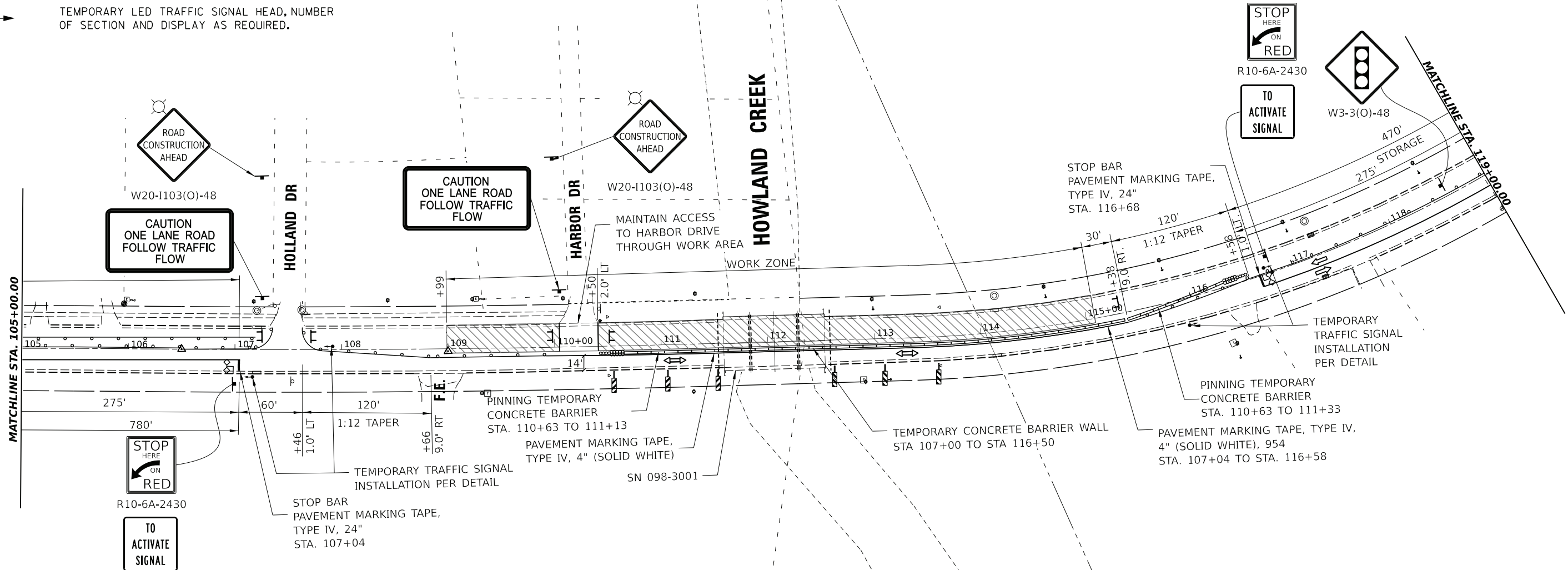
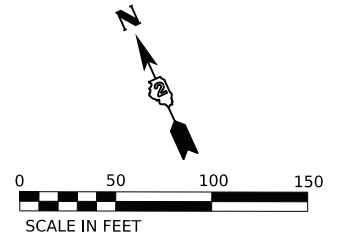

MODEL: Default
 FILE NAME: R:\P\County\7164 Whiteside Co - Dixon Ave Bridge\CADD\CADD_Civil_Erecting_Sch07-7164-Stage 1-02.dgn













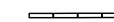

USER NAME = jmadara	DESIGNED - ARF	REVISED -
DRAWN - JDM	REVISOR -	
PLOT SCALE = 50,000' / in.	CHECKED - TWO	REVISOR -
PLOT DATE = 2/16/2023	DATE - 02/15/2023	REVISOR -

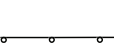
STATE OF ILLINOIS
DEPARTMENT OF TRANSPORTATION

MAINTENANCE OF TRAFFIC - STAGE I
CH 3 (DIXON AVENUE) OVER HOWLAND CREEK

F.A.U. RTE.	SECTION	COUNTY	TOTAL SHEETS	SHEET NO.
5560	I7-00228-00-BR	WHITESIDE	39	7
PROJECT 7164 ILLINOIS FED. AID PROJECT				

PLAN LEGEND

-  WORK ZONE
-  TEMPORARY CONCRETE BARRIER
-  SIGN ON PERMANENT OR PORTABLE SUPPORT
-  DOUBLE VERTICAL PANEL AT 25' MIN. 1' FROM EDGE OF PAVEMENT
-  TYPE III BARRICADE WITH FLASHING MONODIRECTIONAL LIGHTS
-  IMPACT ATTENUATORS, TEMPORARY (NON-REDIRECTIVE), TEST LEVEL 2
-  DRUM AT 50' C-C SPACING IN TANGENT, 20' C-C SPACING TAPERS, AND 10' C-C SPACING IN CURVES/RADII
-  TEMPORARY LED TRAFFIC SIGNAL HEAD, NUMBER OF SECTION AND DISPLAY AS REQUIRED.
-  DETECTOR LOOPS
-  FLEXIBLE DELINEATOR
-  TRAFFIC FLOW
-  DRUM WITH STEADY BURN MONODIRECTIONAL LIGHT
-  DIRECTION INDICATOR BARRICADE WITH STEADY BURN MONODIRECTIONAL LIGHT
-  TYPE II BARRICADE, DRUM OR VERTICAL BARRICADE WITH MONODIRECTIONAL FLASHING LIGHT
-  ARROW BOARD

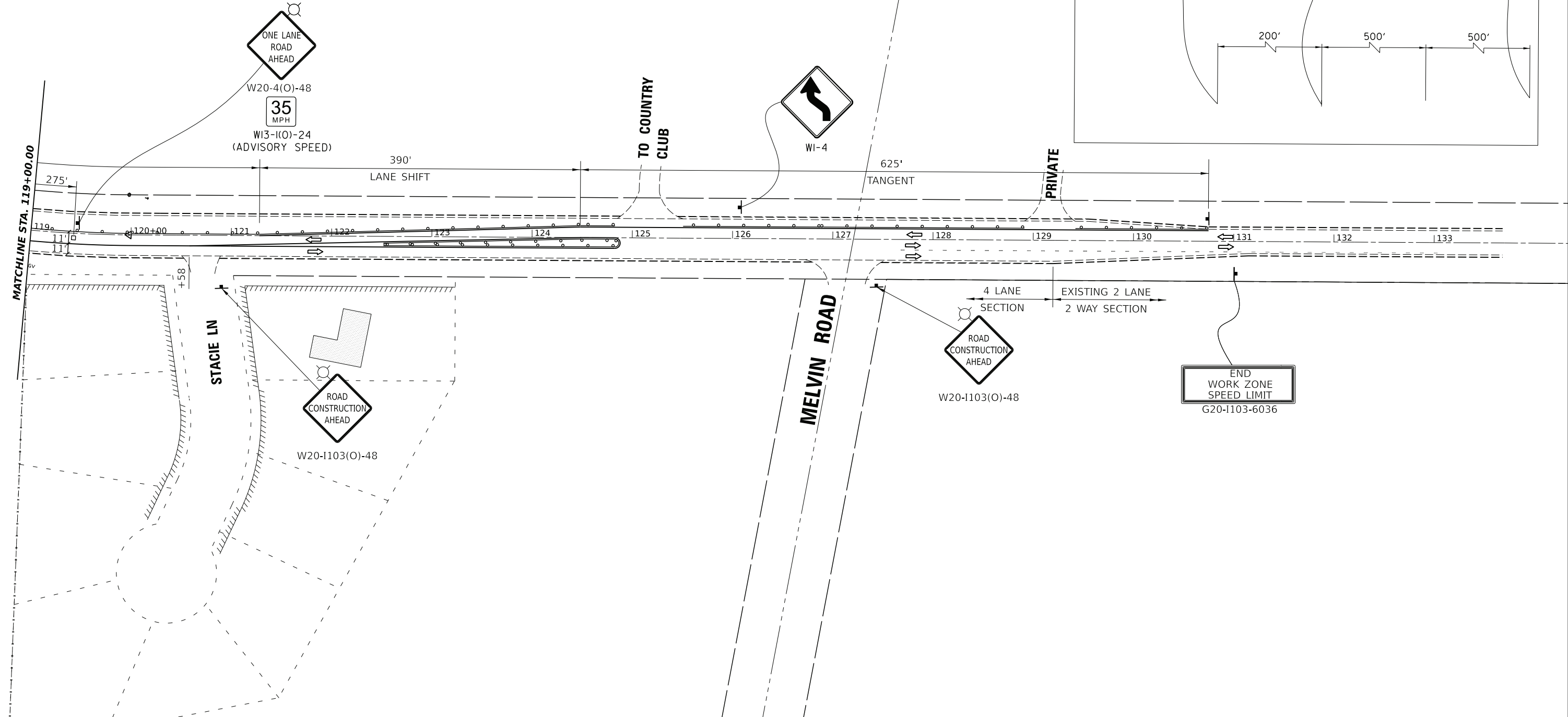
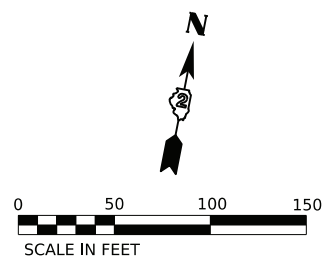

MODEL: Default
 FILE NAME: R:\P1_County\7164 Whiteside Co - Dixon Ave Bridge\CADD\CADD_Civil_Erecting_Sc087164-Stage1\03.dgn

CHASTAIN & ASSOCIATES LLC
CONSULTING ENGINEERS

USER NAME = jmadara	DESIGNED - ARF	REVISED -
DRAWN - JDM	REVISED -	
PLOT SCALE = 50,000' / in.	CHECKED - TWO	REVISED -
PLOT DATE = 2/16/2023	DATE - 02/15/2023	REVISED -















**STATE OF ILLINOIS
DEPARTMENT OF TRANSPORTATION**

**MAINTENANCE OF TRAFFIC - STAGE I
CH 3 (DIXON AVENUE) OVER HOWLAND CREEK**

F.A.U. RTE.	SECTION	COUNTY	TOTAL SHEETS	SHEET NO.
5560	I7-00228-00-BR	WHITESIDE	39	8
CONTRACT NO.				
PROJECT 7164	ILLINOIS	FED. AID PROJECT		

SCALE: SHEET OF SHEETS STA. TO STA.

PLAN LEGEND

-  WORK ZONE
-  TEMPORARY CONCRETE BARRIER
-  SIGN ON PERMANENT OR PORTABLE SUPPORT
-  DOUBLE VERTICAL PANEL AT 25' MIN. 1' FROM EDGE OF PAVEMENT
-  TYPE III BARRICADE WITH FLASHING MONODIRECTIONAL LIGHTS
-  IMPACT ATTENUATORS, TEMPORARY (NON-REDIRECTIVE), TEST LEVEL 2
-  DRUM AT 50' C-C SPACING IN TANGENT, 20' C-C SPACING TAPERS, AND 10' C-C SPACING IN CURVES/RADII
-  TEMPORARY LED TRAFFIC SIGNAL HEAD, NUMBER OF SECTION AND DISPLAY AS REQUIRED.
-  DETECTOR LOOPS
-  FLEXIBLE DELINEATOR
-  TRAFFIC FLOW
-  DRUM WITH STEADY BURN MONODIRECTIONAL LIGHT
-  DIRECTION INDICATOR BARRICADE WITH STEADY BURN MONODIRECTIONAL LIGHT
-  TYPE II BARRICADE, DRUM OR VERTICAL BARRICADE WITH MONODIRECTIONAL FLASHING LIGHT
-  ARROW BOARD

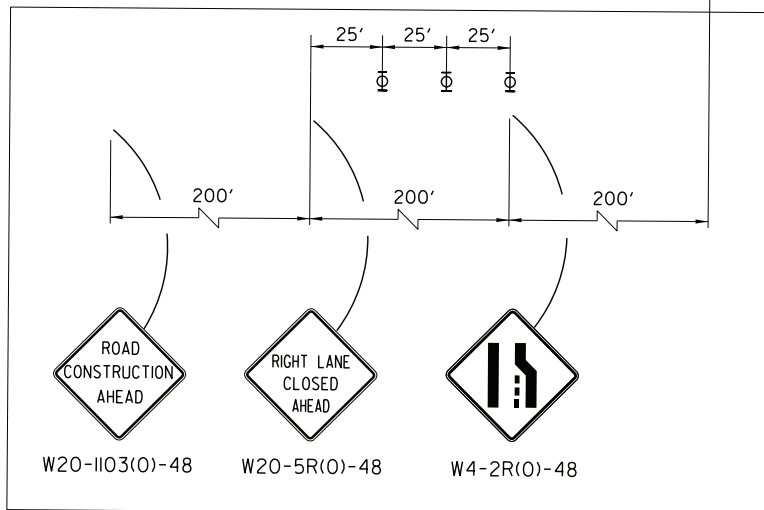
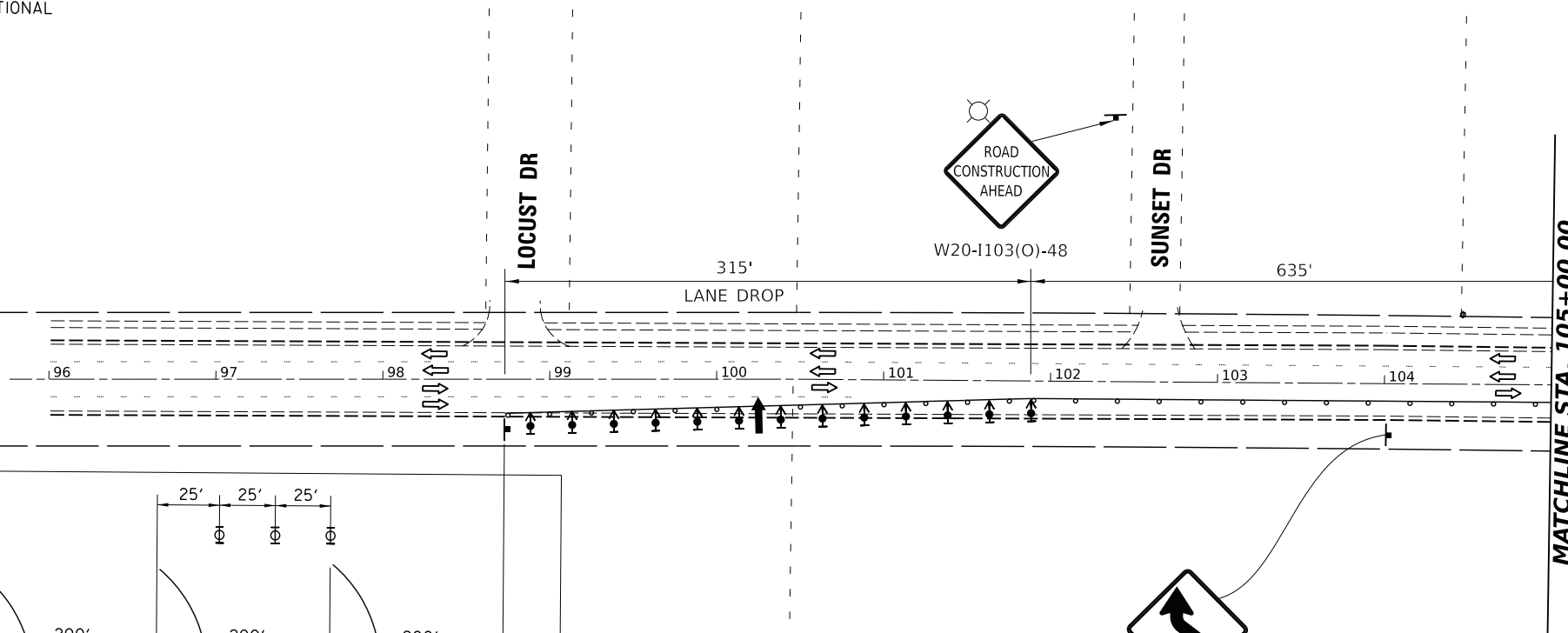

MODEL: D:\proj\CH3\County\7164\Whiteside Co - Dixon Ave Bridge\CADD\CADD_Civil_Erecting_Sch08-7164-Stage II-01.dgn
 FILE NAME: RCP1_County\7164\Whiteside Co - Dixon Ave Bridge\CADD\CADD_Civil_Erecting_Sch08-7164-Stage II-01.dgn



USER NAME = jmadara	DESIGNED - ARF	REVISED -
DRAWN - JDM	REVISIONS -	
PLOT SCALE = 50,000' / in.	CHECKED - TWO	REVISIONS -
PLOT DATE = 2/20/2023	DATE - 02/15/2023	REVISIONS -

**STATE OF ILLINOIS
DEPARTMENT OF TRANSPORTATION**

**MAINTENANCE OF TRAFFIC - STAGE II
CH 3 (DIXON AVENUE) OVER HOWLAND CREEK**

SCALE: SHEET OF SHEETS STA. TO STA.

F.A.U. RTE.	SECTION	COUNTY	TOTAL SHEETS	SHEET NO.
5560	I7-00228-00-BR	WHITESIDE	39	9
PROJECT 7164 ILLINOIS FED. AID PROJECT				

NOTES

WHEN THE BARRIER IS RELOCATED WITHIN THE LIMITS OF THE JOBSITE, THE RELOCATED BARRIER WILL BE MEASURED FOR PAYMENT IN FEET (METERS) IN PLACE ALONG THE CENTERLINE OF THE BARRIER.

WHEN RELOCATION OF TEMPORARY IMPACT ATTENUATORS IS SPECIFIED, THEY SHALL BE REMOVED, RELOCATED, AND REINSTALLED AT THE NEW LOCATION. THE REINSTALLATION REQUIREMENTS SHALL BE THE SAME AS THOSE FOR A NEW INSTALLATION.

WHEN IMPACT ATTENUATORS HAVE BEEN ANCHORED TO THE PAVEMENT, THE ANCHOR HOLES SHALL BE REPAIRED WITH RAPID SET MORTAR; ONLY ENOUGH WATER TO PERMIT PLACEMENT AND CONSOLIDATION BY RODDING SHALL BE USED AND THE MATERIAL SHALL BE STRUCK-OFF FLUSH.

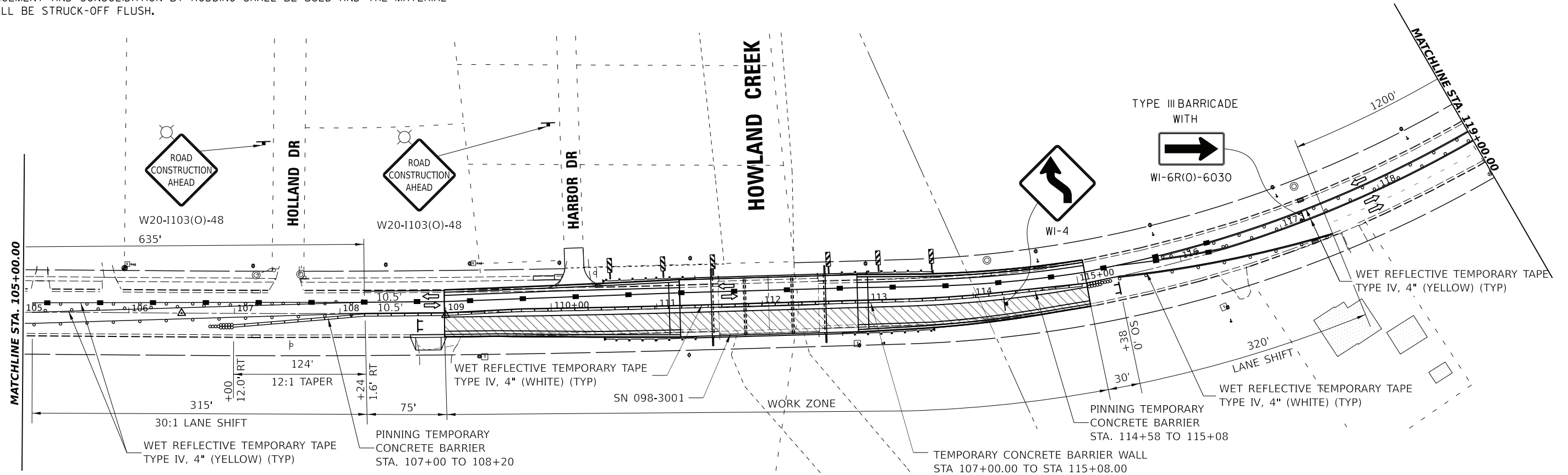
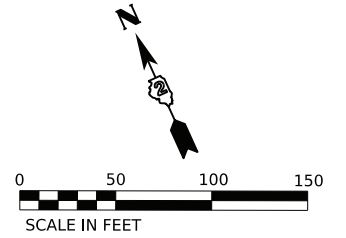

PLAN LEGEND

- WORK ZONE
- TEMPORARY CONCRETE BARRIER
- SIGN ON PERMANENT OR PORTABLE SUPPORT
- DOUBLE VERTICAL PANEL AT 25' MIN. 1' FROM EDGE OF PAVEMENT
- TYPE III BARRICADE WITH FLASHING MONODIRECTIONAL LIGHTS
- IMPACT ATTENUATORS, TEMPORARY (NON-REDIRECTIVE), TEST LEVEL 2
- DRUM AT 50' C-C SPACING IN TANGENT, 20' C-C SPACING TAPERS, AND 10' C-C SPACING IN CURVES/RADII
- TEMPORARY LED TRAFFIC SIGNAL HEAD, NUMBER OF SECTION AND DISPLAY AS REQUIRED.
- DETECTOR LOOPS
- FLEXIBLE DELINEATOR
- TRAFFIC FLOW
- DRUM WITH STEADY BURN MONODIRECTIONAL LIGHT
- DIRECTION INDICATOR BARRICADE WITH STEADY BURN MONODIRECTIONAL LIGHT
- TYPE II BARRICADE, DRUM OR VERTICAL BARRICADE WITH MONODIRECTIONAL FLASHING LIGHT
- ARROW BOARD

MODEL: D:\proj\CH3\County\7164\Whiteside Co - Dixon Ave Bridge\CADD\CADD_Civil\ Erecting Sect\107164-Stage II-02.dgn



USER NAME = jmadara	DESIGNED - ARF	REVISED -
DRAWN - JDM	REVISED -	
PLOT SCALE = 50,000' / in.	CHECKED - TWO	REVISED -
PLOT DATE = 2/20/2023	DATE - 02/15/2023	REVISED -















**STATE OF ILLINOIS
DEPARTMENT OF TRANSPORTATION**

**MAINTENANCE OF TRAFFIC - STAGE II
CH 3 (DIXON AVENUE) OVER HOWLAND CREEK**

F.A.U. RTE.	SECTION	COUNTY	TOTAL SHEETS	SHEET NO.
5560	17-00228-00-BR	WHITESIDE	39	10
CONTRACT NO.				
PROJECT 7164 ILLINOIS FED. AID PROJECT				

SCALE: SHEET OF SHEETS STA. TO STA.

PLAN LEGEND

-  WORK ZONE
-  TEMPORARY CONCRETE BARRIER
-  SIGN ON PERMANENT OR PORTABLE SUPPORT
-  DOUBLE VERTICAL PANEL AT 25' MIN. I' FROM EDGE OF PAVEMENT
-  TYPE III BARRICADE WITH FLASHING MONODIRECTIONAL LIGHTS
-  IMPACT ATTENUATORS, TEMPORARY (NON-REDIRECTIVE), TEST LEVEL 2
-  DRUM AT 50' C-C SPACING IN TANGENT, 20' C-C SPACING TAPERS, AND 10' C-C SPACING IN CURVES/RADII
-  TEMPORARY LED TRAFFIC SIGNAL HEAD, NUMBER OF SECTION AND DISPLAY AS REQUIRED.
-  DETECTOR LOOPS
-  FLEXIBLE DELINEATOR
-  TRAFFIC FLOW
-  DRUM WITH STEADY BURN MONODIRECTIONAL LIGHT
-  DIRECTION INDICATOR BARRICADE STEADY BURN MONODIRECTIONAL
-  TYPE II BARRICADE, DRUM OR VE BARRICADE WITH MONODIRECTION FLASHING LIGHT
-  ARROW BOARD

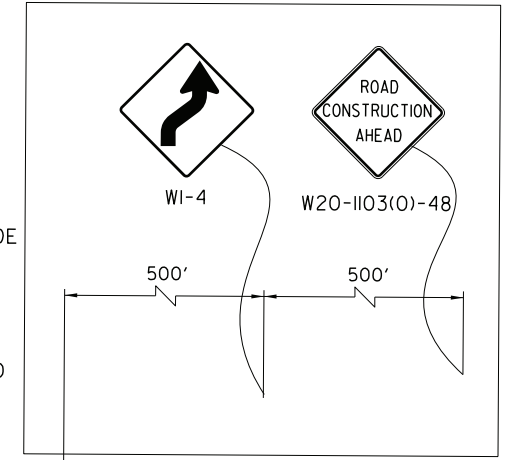
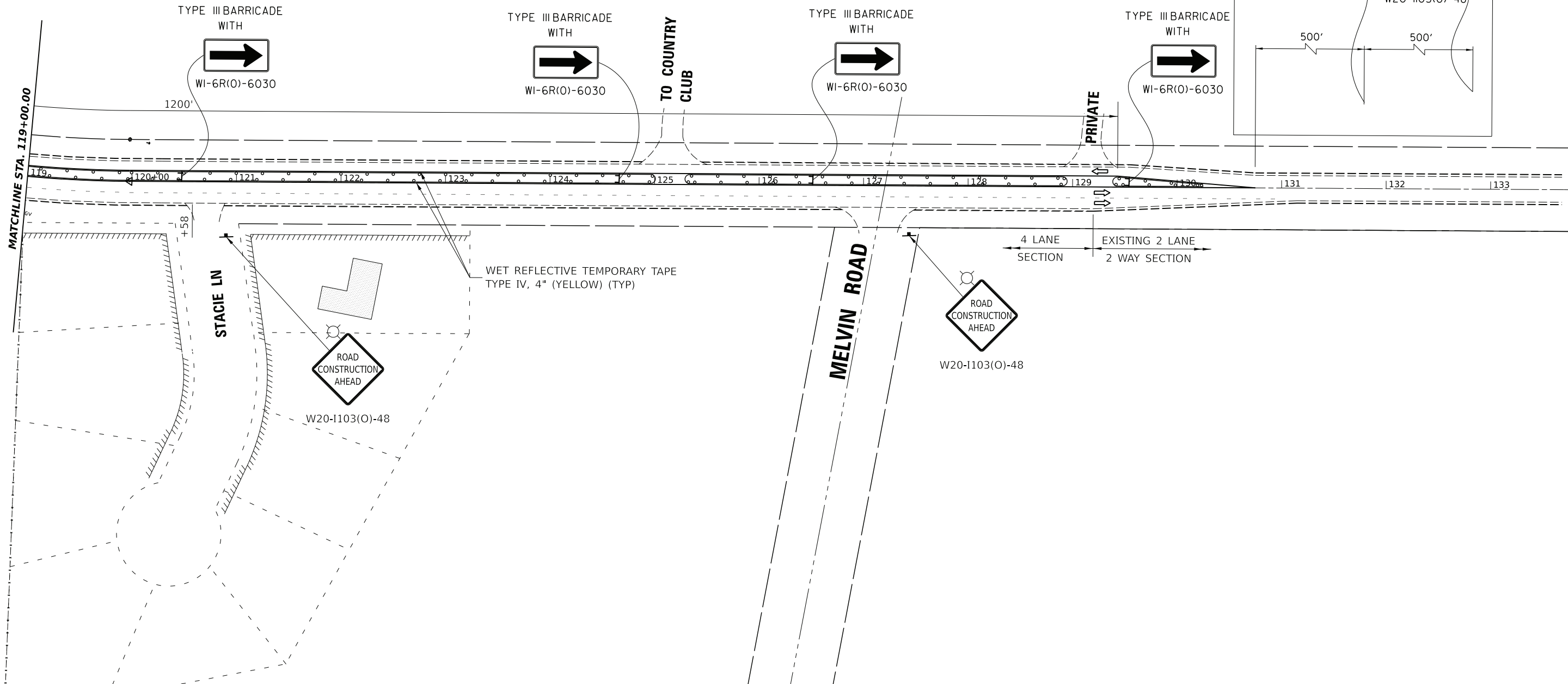
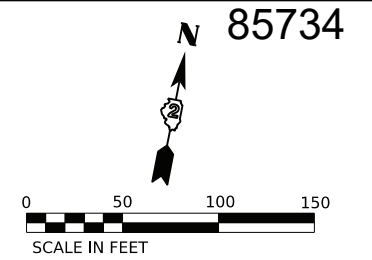

MODEL: D:\proj\17164\17164-Stage II\17164-Stage II.dwg
 FILE NAME: R:\proj\17164\17164-Stage II\17164-Stage II.dwg
 PROJECT: County 17164 Whiteside Co., Dixon Ave Bridge/CADD/CADD_Civil_Erecting Set11-17164-Stage II-03.dwg

	USER NAME = jmadara	DESIGNED - ARF	REVISED -
	PLOT SCALE = 50,000' / in.	DRAWN - JDM	REVISED -
	PLOT DATE = 2/16/2023	CHECKED - TWO	REVISED -
		DATE - 02/15/2023	REVISED -

STATE OF ILLINOIS
DEPARTMENT OF TRANSPORTATION

MAINTENANCE OF TRAFFIC - STAGE II
CH 3 (DIXON AVENUE) OVER HOWLAND CREEK

F.A.U. RTE.	SECTION	COUNTY	TOTAL SHEETS	SHEET NO.
5560	I7-00228-00-BR	WHITESIDE	39	11
CONTRACT NO.				
PROJECT 7164 ILLINOIS FED. AID PROJECT				

SCALE: SHEET OF SHEETS STA. TO STA.

Bench Mark: #1 60D Nail in Power Pole Sta. 105+97, 42.3' LT. Elevation 645.16
 #2 60D Nail in Power Pole Sta. 117+06, 40.9' LT. Elevation 647.26

Existing Structure: S.N. 098-3001 built 1967 as County Highway No. 3, Section 38-B-MFT at Station 112+07.83. Rehabilitated in 1983 as Section 83-00081-00-BR. Structure consists of three span reinforced concrete slab supported by spill-thru abutments and open concrete pile bent piers. 95.3' back-to-back abutments. 50.3' out-to-out deck. Structure to be removed and replaced using stage construction.

Note: All Channel excavation for the new structure back-to-back of abutments as shown, from ROW to ROW, will not be paid for separately, and the cost of channel excavation & hauling excess material shall be included in the cost of removal of existing structures. No additional compensation will be allowed.

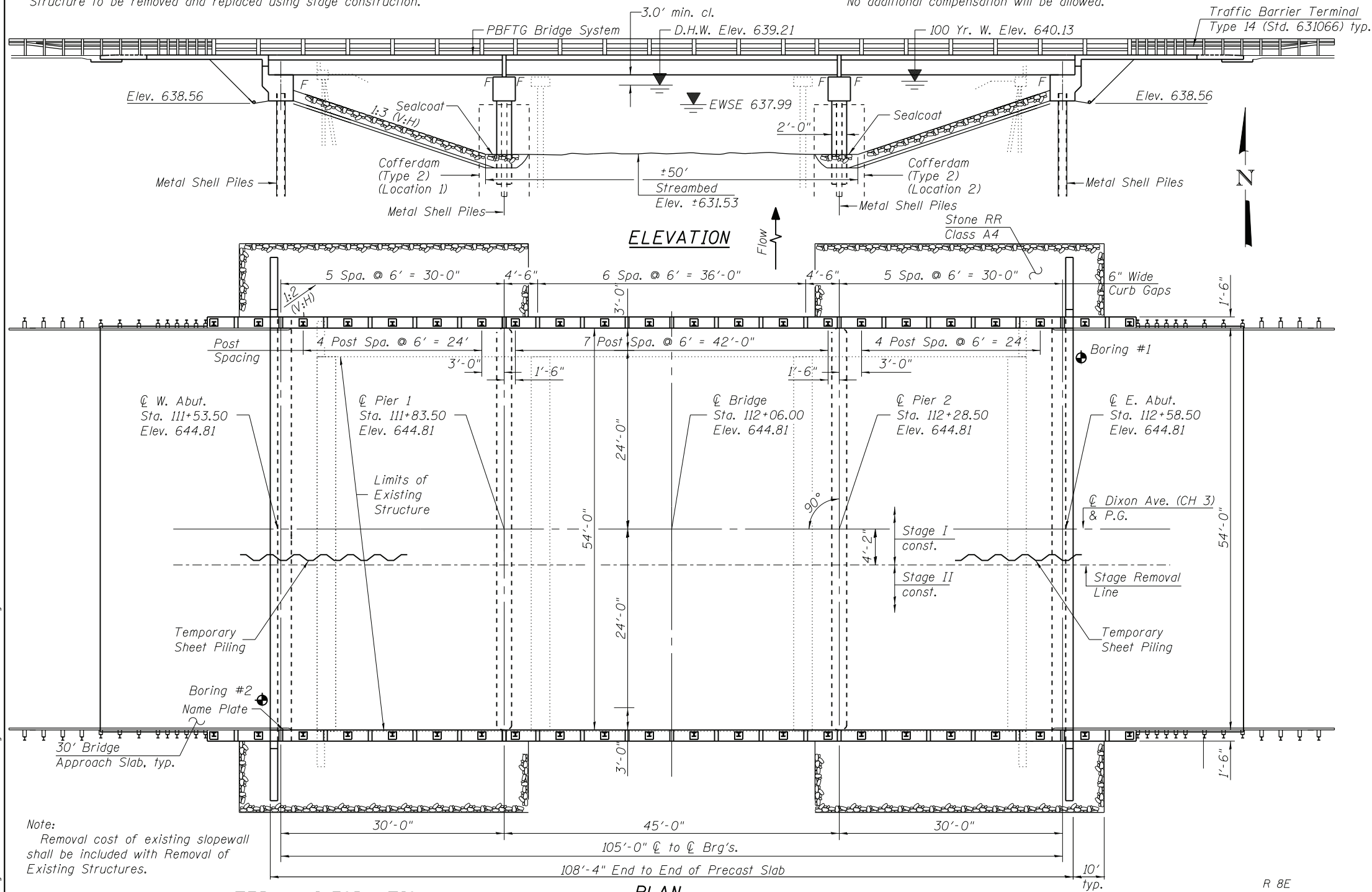

Note: Removal cost of existing slopewall shall be included with Removal of Existing Structures.

WATERWAY INFORMATION

Flood	Freq. Yr.	Q C.F.S.	Opening Sq. Ft.		Nat. H.W.E.		Head - Ft.		Headwater El.	
			Exist.	Prop.	Exist.	Prop.	Exist.	Prop.	Exist.	Prop.
Design	30	2,750	365	450	639.21	0.36	0.24	639.57	639.45	
Base	100	3,570	442	537	640.13	0.40	0.25	640.53	640.38	
Overtopping	-	-	-	-	-	-	-	-	-	
Max. Calc.	500	4,680	529	636	641.19	0.08	-0.09	641.27	641.10	

10 Year Velocity Through Existing Bridge = 7.55 ft/s
 10 Year Velocity Through Proposed Bridge = 6.77 ft/s

PLAN

DESIGN SCOUR ELEVATION TABLE

Flood	Design Scour Elevations (ft.)			
	W. Abut.	E. Abut.	E. Pier	W. Pier
Base	100	624.53	626.73	624.53
Max. Calc	500	623.04	626.73	623.04

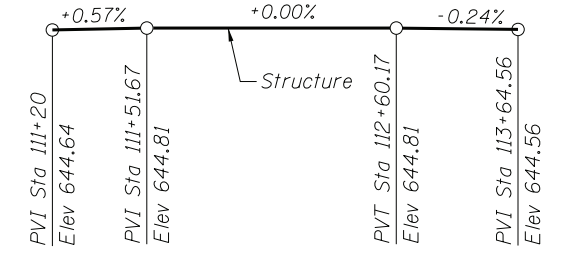
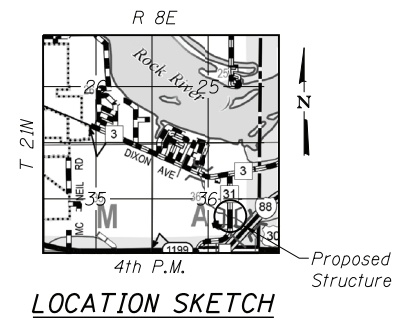

CONSTRUCTION PROFILE

LOADING HL-93

Allow 50 lb/sq. ft. for future wearing surface.

DESIGN SPECIFICATIONS

2014 AASHTO LRFD Bridge Design Specifications, 7th Edition with 2016 Interims

DESIGN STRESSES

FIELD UNITS

- f'c = 4,000 psi (superstructure)
- f'c = 3,500 psi (substructure)
- fy = 60,000 psi (reinforcement)
- fy = 50,000 psi (M270 Gr 50)

SEISMIC DATA

Seismic Performance Zone (SPZ) = 1
 Design Spectral Acceleration at 1.0 sec (S₀₁) = 0.074
 Design Spectral Acceleration at 0.2 sec (S₀₅) = 0.116
 Soil Site Class = D

ADT/ADTT

Functional Classification - Minor Arterial
 2016 ADT = 3150
 2016 ADTT = 378
 Design Speed = 40 mph

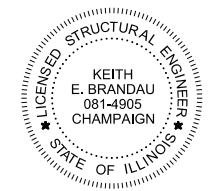

Keith E. Brandau 03/05/2022

Keith E. Brandau, P.E., S.E. Date
 License Expires 11/30/2024

I certify that to the best of my knowledge, information and belief, this bridge design is structurally adequate for the design loading shown on the plans. The design is an economical one for the style of structure and complies with requirements of the current AASHTO Bridge Design Specifications.

GENERAL PLAN AND ELEVATION
CTY HWY 3 (DIXON AVE) OVER HOWLAND CREEK
F.A.U. 5560 - SEC. 17-00228-00-BR
WHITESIDE COUNTY
STATION 112+06.00
STRUCTURE NO. 098-3079

FILE NAME = R:\P\J\County\7164 Whiteside Co - Dixon Ave Bridge\CADD\Structural\Freeing Set\12-7164-Gen Plan & Elev.dgn



USER NAME = jmadara	DESIGNED KEB	REVISED -
PLOT TIME = 3:48:45 PM	DRAWN JDM	REVISED -
PLOT SCALE = 8,0000' / 1"	CHECKED JMB	REVISED -
PLOT DATE = 2/15/2023	DATE 02/15/2023	REVISED -

STATE OF ILLINOIS
DEPARTMENT OF TRANSPORTATION

GENERAL PLAN AND ELEVATION
STRUCTURE NO. 098-3079
 SHEET NO. 1 OF 16 SHEETS

FAU RTE	SECTION	COUNTY	TOTAL SHEETS	SHEET NO.
5560	17-00228-00-BR	WHITESIDE	39	12
CONTRACT NO. 85734				
ILLINOIS FED. AID PROJECT				

GENERAL NOTES:

- Engineer of record shall ensure deck slab design and details, barriers and miscellaneous steel details are in accordance with project requirements. deck slab design and details, barriers and miscellaneous steel details are per project and owner requirements.
- All structural steel hardware shall be mechanically galvanized, per ASTM A153.
- High strength bolts: ASTM F3125 Gr A325, Type I
Anchor bolts: ASTM F1554, Grade 55
Nuts: ASTM A563/A563U, Grade DH
Washers: ASTM F436/F436M, Type I
- Tighten all bolts using the turn of the nut method per research council on structural connections (RCD) requirements for slip critical connections.
- A higher strength concrete may be substituted for a lower strength concrete, if approved by the bridge engineer of record.
- All fabricated steel shall be hot dip galvanized per AASHTO M11 (ASTM A123).
- Weld shear studs to steel surfaces and perform preproduction test as required in AASHTO/AWS D1.5 (2015). Shear connector studs must meet the requirements of AASHTO 169. For cold finish carbon steel, cold-drawn bar, Grade 1015 or Grade 1020, either semi-killed or fully killed.
- The quantity, size, and location of placement for each shear stud type specified per approved shop drawings. Shear stud weld shall be checked for uniformity around the base. a specified number (1 percent) of all shear studs shall be bent 10°-15° out of plumb, using an eight-pound hammer.
- Do not field-weld on any part of the bridge, except where shown on the drawings, without prior approval of the Engineer.
- No field welding is permitted except as specified in the contract documents.
- Reinforcement bars shall conform to the requirements of ASTM A 706 Gr 60.
- Reinforcement bars designated (E) shall be epoxy coated.
- Bearing seat surfaces shall be constructed or adjusted to the designated elevations within a tolerance of 1/8 in. (0.01 ft.). Adjustment shall be made either by grinding the surface or by shimming the bearings.
- Layout of slope protection system may be varied to suit ground conditions in the field as directed by the ENGINEER. The embankment configuration shown shall be the minimum that must be placed and compacted prior to construction of the abutments.
- Sealcoat thickness design to be based on the Estimated Water Surface Elevation (EWSE). Cofferdam design and sealcoat thickness design to be submitted to the Engineer for approval with cofferdam design.
- The Contractor shall obtain a construction permit from the Illinois Department of Natural Resources (IDNR), Office of Water Resources for any temporary construction activity placed in the water except construction as shown in the plans or as allowed in the Special Provision for Temporary Stream Crossings and In - Stream Work Pads.

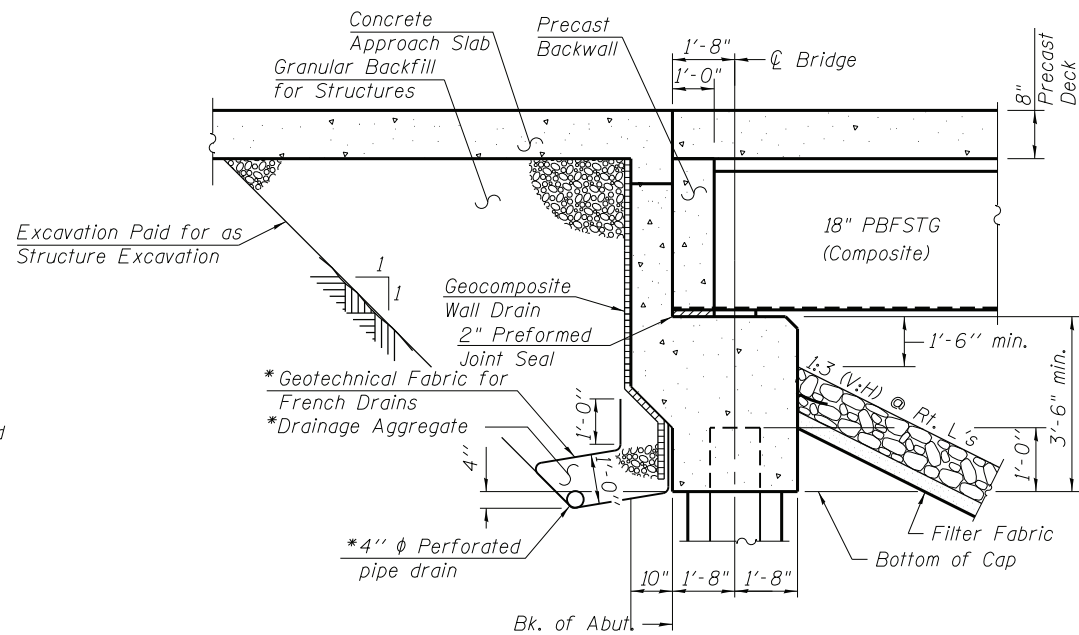

SECTION THRU ABUTMENT
(Dimensions are at Rt. L's)

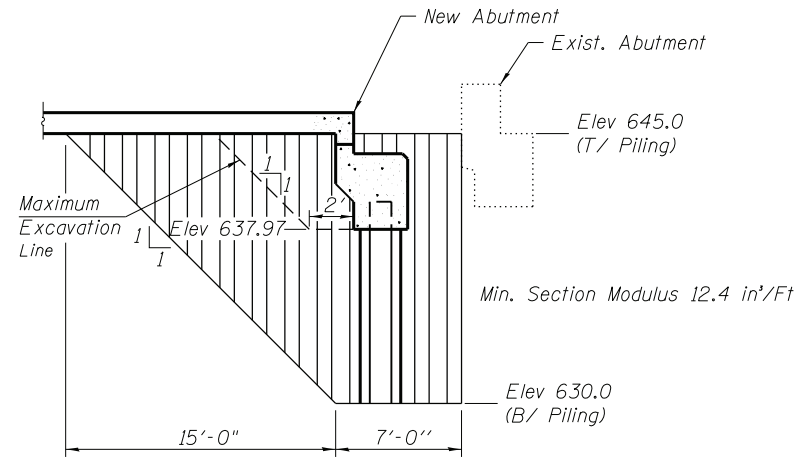

TEMPORARY SHEET PILING DETAIL
(Typ. Both Abutments)

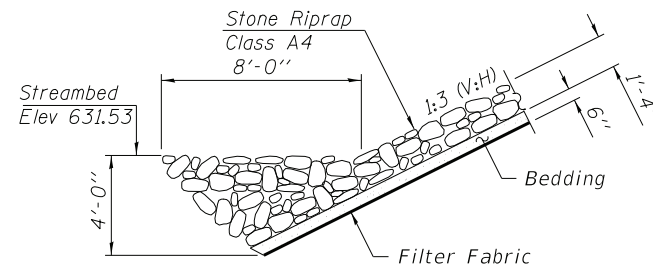

STONE RIPRAP ANCHOR DETAIL

Note:
All drainage system components shall extend to 2'-0" from the end of each wingwall except an outlet pipe shall extend until intersecting with the side slopes. The pipes shall drain into concrete headwalls. (See Article 601.05 of the Standard Specifications and Highway Standard 601101).

* Included in the cost of Pipe Underdrain for Structures

INDEX OF SHEETS

- General Plan and Elevation
- General Data
- Stage Construction Details
- Temporary Concrete Barrier
- Superstructure
- Superstructure Details
- Bridge Approach Slab Details
- Steel Railing Type CO-10
- Structural Steel
- Structural Steel Details
- West Abutment
- East Abutment
- Pier Details
- Metal Shell Pile Details
- Bar Splicer Assembly And Mechanical Splicer Details

HOWLAND CREEK
BUILT 20 BY
WHITESIDE COUNTY
SEC. 17-00228-00-BR
DIXON AVE CH 3 STA. 112+06.00
STR. NO. 098-3079 LOADING HL-93

NAME PLATE
See Std. 515001

TOTAL BILL OF MATERIAL

ITEM	UNIT	SUPER	SUB	TOTAL
Granular Backfill for Structures	Cu. Yd.		56	56
Stone Riprap, Class A4	Sq. Yd.		650	650
Filter Fabric	Sq. Yd.		650	650
Removal of Existing Structures	Each			1
Structure Excavation	Cu. Yd.		288	288
Cofferdam Excavation	Cu. Yd.		430	430
Concrete Structures	Cu. Yd.		259.0	259.0
Bridge Deck Grooving	Sq. Yd.	626		626
Protective Coat	Sq. Yd.		738	738
Erecting Superstructure	Sq. Ft.	6175		6175
Reinforcement Bars, Epoxy Coated	Pound	62,100	22,350	84,450
Bar Splicers	Each		400	400
Furnishing Metal Shell Piles 14" x 0.250"	Foot		1415	1415
Driving Piles	Foot		1415	1415
Pile Shoes	Each		42	42
Test Pile Metal Shells	Each		4	4
Temporary Sheet Piling	Sq. Ft.		435	435
Steel Railing, Type CO-10	Foot	277		277
Name Plates	Each	1		1
Anchor Bolts, 1"	Each		108	108
Geocomposite Wall Drain	Sq. Yd.		90	90
Pipe Underdrains for Structures 4"	Foot		180	180
Cofferdam Type 2 - Location 1	Each		1	1
Cofferdam Type 2 - Location 2	Each		1	1
Seal Coat Concrete	Cu. Yd.		238	238
Concrete Superstructure (Approach Slab)	Cu. Yd.	156.3		156.3
Concrete Superstructure	Cu. Yd.	2.2		2.2
Polymer Modified Cement Mortar	Sq. Ft.	692		692

FILE NAME = R:\P\J\County\7164 Whiteside Co - Dixon Ave Bridge\CADD\CADD_Structure\1_Erecting Set\13-7164-Gen Data.dgn



USER NAME = jmadara
PLOT TIME = 3:49:52 PM
PLOT SCALE = 8.0000' / 1" =
PLOT DATE = 2/15/2023

DESIGNED KEB
DRAWN JDM
CHECKED JMB
DATE 02/15/2023

REVISED -
REVISED -
REVISED -
REVISED -

STATE OF ILLINOIS
DEPARTMENT OF TRANSPORTATION

GENERAL DATA
STRUCTURE NO. 098-3079

SHEET NO. 2 OF 16 SHEETS

FAU RTE	SECTION	COUNTY	TOTAL SHEETS	SHEET NO.
5560	17-00228-00-BR	WHITESIDE	39	13
CONTRACT NO. 85734				
ILLINOIS FED. AID PROJECT				

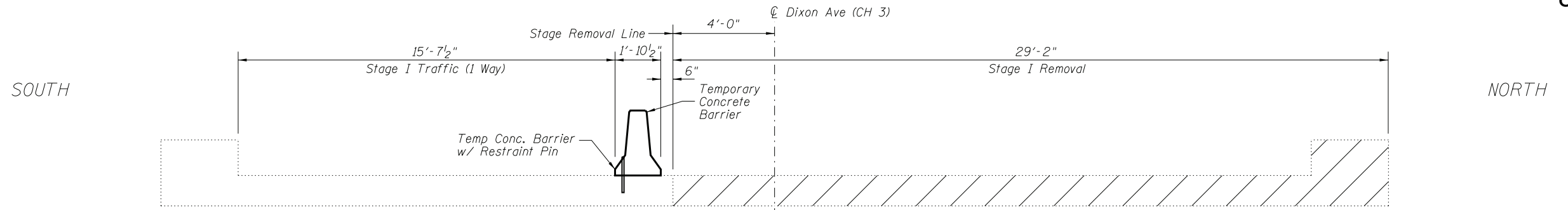

STAGE I REMOVAL
Looking West

Notes:
For quantity of Temporary Concrete Barrier, see roadway plans.
Hatched area indicates Removal of Existing Structures.

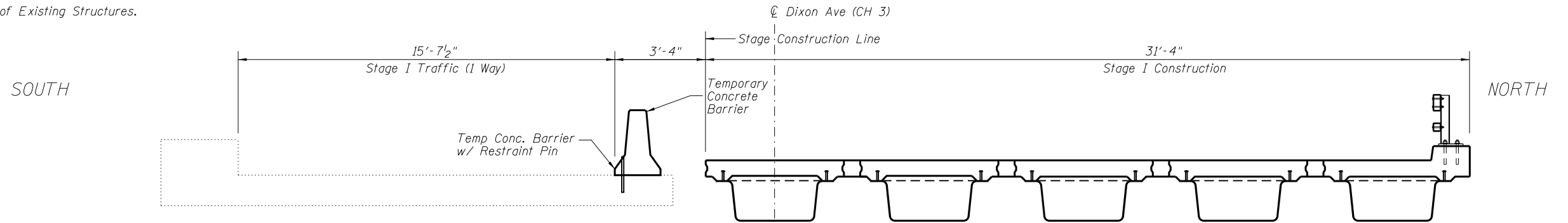

STAGE I CONSTRUCTION
Looking West

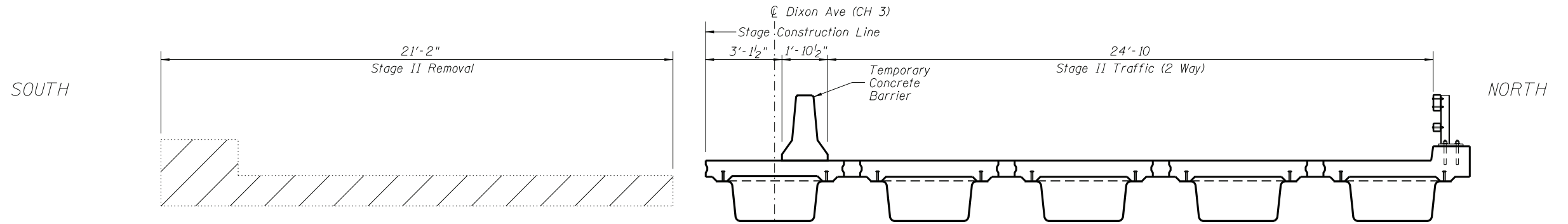

STAGE II REMOVAL
Looking West

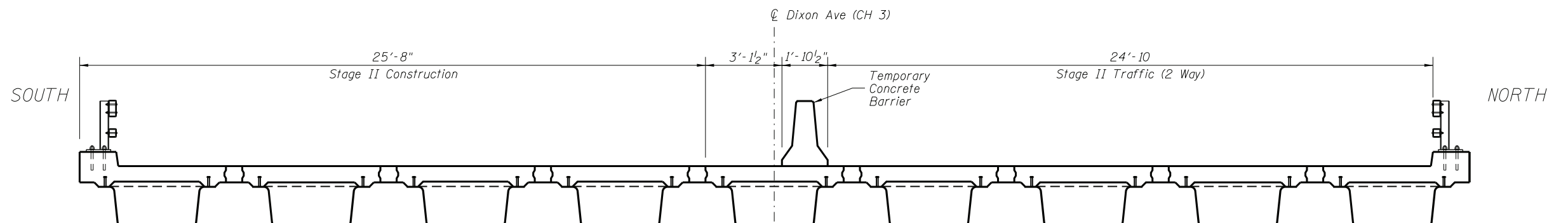

STAGE II CONSTRUCTION
Looking West

FILE NAME = R:\P\J\County\7164 Whiteside Co - Dixon Ave Bridge\CADD\CADD_Structural\1-Precting Set\14-7164-Stage Const.dgn

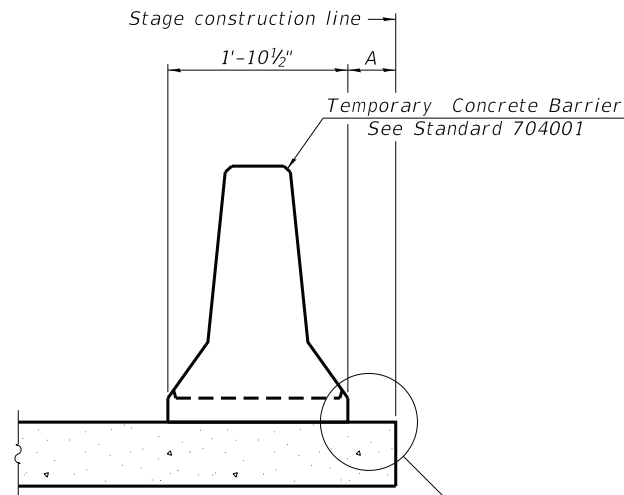

When "A" is 3'-1" or less, the temporary concrete barrier shall be restrained to the new slab according to Detail I, II or III. No restraint is required when "A" is greater than 3'-1". See Detail I, II or III

NEW SLAB OR NEW DECK BEAM

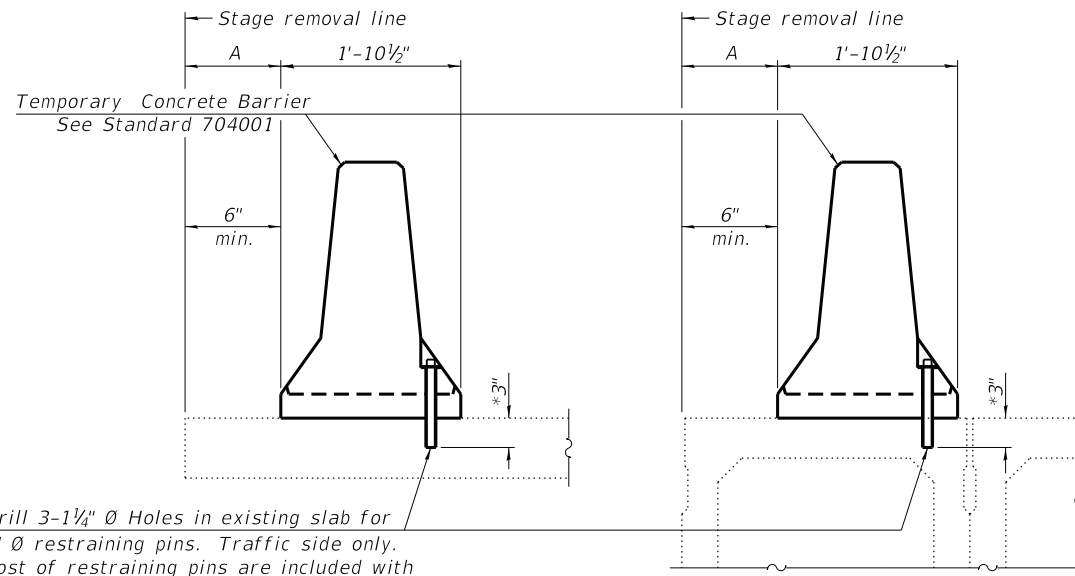

Drill 3-1/4" Ø Holes in existing slab for 1" Ø restraining pins. Traffic side only. Cost of restraining pins are included with Temporary Concrete Barrier. No restraint is required when "A" is greater than 3'-1".

EXISTING SLAB

EXISTING DECK BEAM

SECTIONS THRU SLAB OR DECK BEAM

* When hot-mix asphalt wearing surface is present, embedment shall be 3" plus the wearing surface depth.

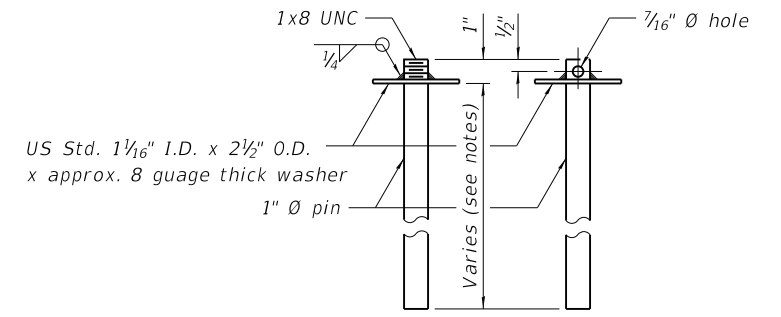

RESTRAINING PIN

Notes:
 Cost of retainer assembly is included with Temporary Concrete Barrier.
 A retainer assembly shall be located at the approximate $\frac{1}{2}$ of each temporary concrete barrier.
 The retainer plate shall not be removed until the concrete on the adjacent stage is ready to be poured. For Detail III applications the retainer plate shall not be removed until just prior to placing the adjacent beam.
 When the 'A' dimension is less than 1 1/2", the wood block shall be omitted and the barrier shall be placed in direct contact with the steel retainer plate.
 For deck beam applications the minimum required 'A' distance is 6" to accommodate the shear key clamping device.

FILE NAME = R:\P\J\County\7164 Whiteside Co - Dixon Ave Bridge\CADD\CADD.Structural\Freestng Set\15-7164-Temp Barrier.dgn



USER NAME = jmadara	DESIGNED <i>KEB</i>	REVISED -
PLOT TIME = 10:54:26 AM	DRAWN <i>JDM</i>	REVISED -
PLOT SCALE = 2.0000' / 1"	CHECKED <i>JMB</i>	REVISED -
PLOT DATE = 2/20/2023	DATE <i>02/15/2023</i>	REVISED -

STATE OF ILLINOIS
DEPARTMENT OF TRANSPORTATION

TEMPORARY CONCRETE BARRIER FOR STAGE CONSTRUCTION
STRUCTURE NO. 098-3079

SHEET NO. 4 OF 16 SHEETS

FAU RTE	SECTION	COUNTY	TOTAL SHEETS	SHEET NO.
5560	17-00228-00-BR	WHITESIDE	39	15
CONTRACT NO. 85734				
ILLINOIS FED. AID PROJECT				

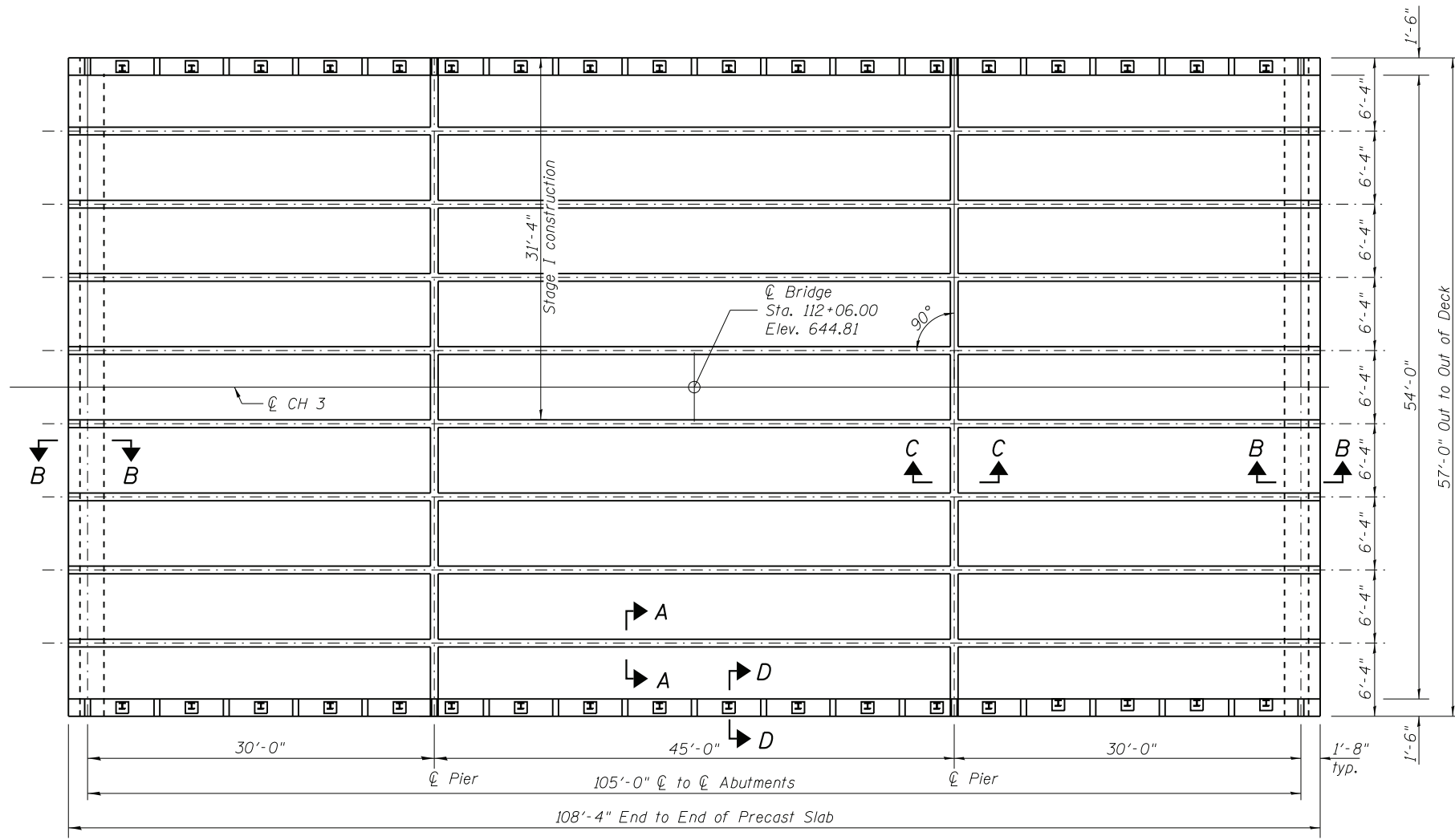

PLAN



MINIMUM BAR LAP
#5 bar = 3'-6"

- Notes:
1. See Sheet 6 of 16 for superstructure details and Bill of Material.
 2. See Sheet 6 of 16 for Section A-A, Section B-B, Section C-C, and diaphragm details.
 3. See Sheet 9 of 16 for railing details.

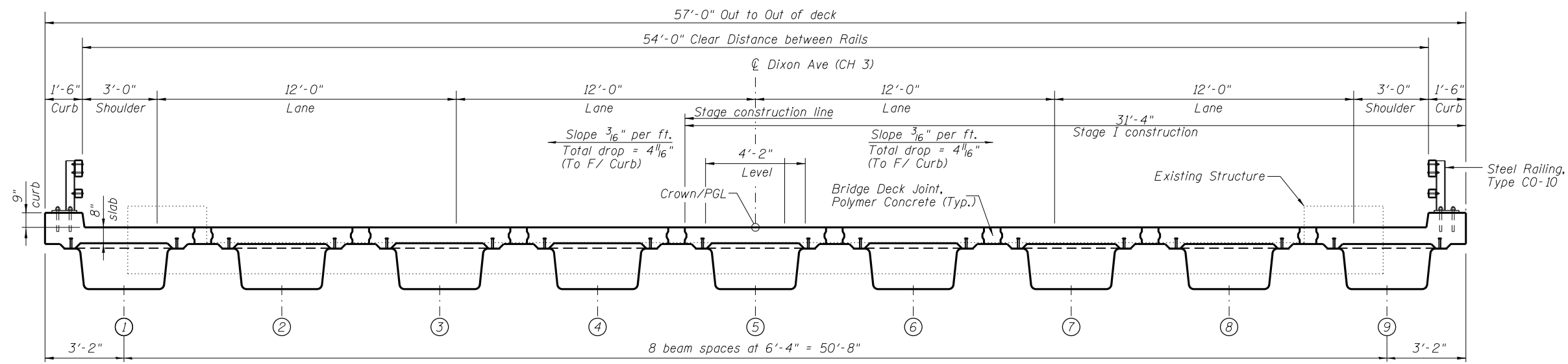

CROSS SECTION
(Looking Up Station)

FILE NAME = R:\P\J\County\7164 Whiteside Co - Dixon Ave Bridge\CADD\Structural\16-7164-Superstructure.dgn

CHASTAIN & ASSOCIATES LLC
CONSULTING ENGINEERS
184-001397

USER NAME = jmadara
PLOT TIME = 4:00:45 PM
PLOT SCALE = 1.0000' / 1"
PLOT DATE = 2/15/2023

DESIGNED <i>KEB</i>
DRAWN <i>JDM</i>
CHECKED <i>JMB</i>
DATE <i>02/15/2023</i>

REVISED -
REVISED -
REVISED -
REVISED -

STATE OF ILLINOIS
DEPARTMENT OF TRANSPORTATION

SUPERSTRUCTURE
STRUCTURE NO. 098-3079

SHEET NO. 5 OF 16 SHEETS

FAU RTE	SECTION	COUNTY	TOTAL SHEETS	SHEET NO.
5560	17-00228-00-BR	WHITESIDE	39	16
CONTRACT NO. 85734				
ILLINOIS FED. AID PROJECT				

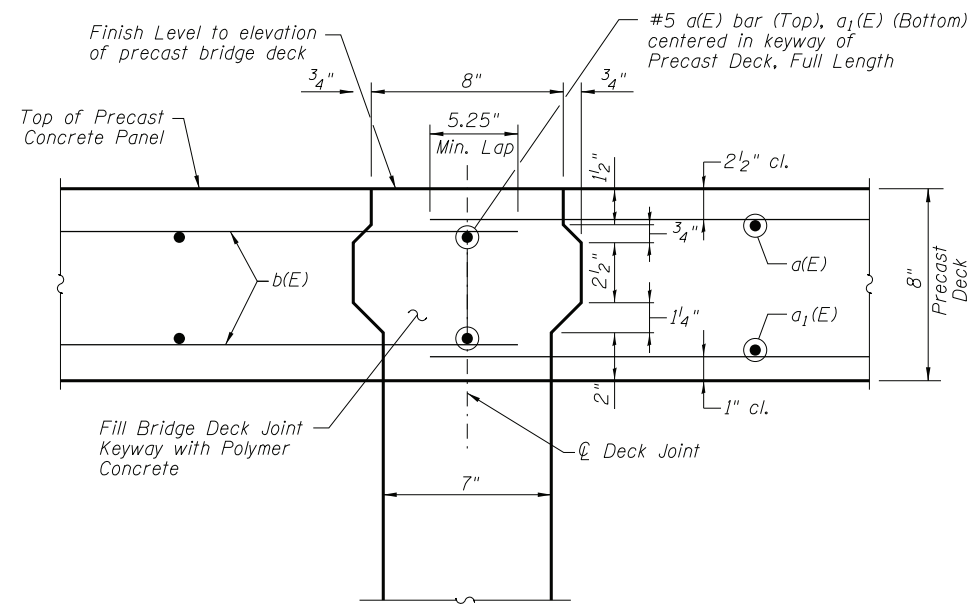
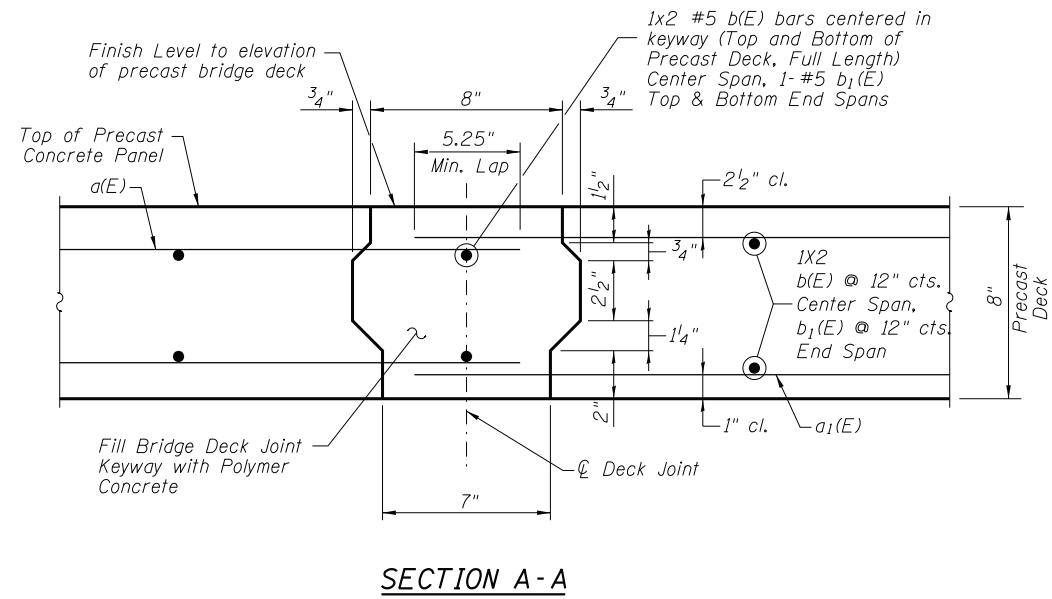

PRECAST DECK REINFORCEMENT BAR LIST

Bar	No.	Size	Length	Shape
a(E)	2178	#5	6'-9"	—
a1(E)	1611	#5	6'-9"	—
b(E)	284	#5	24'-6"	—
b1(E)	284	#5	32'-3"	—
b2(E)	8	#5	4'-10"	—
b3(E)	56	#5	5'-2"	—
b4(E)	8	#5	3'-8"	—
s(E)	200	#5	5'-1"	⌋

Notes:
 All Reinforcement bars in Precast Concrete Deck are included in PBFSTG System and shall be designed per PBFSTG manufacturer.
 Bars shown in precast panels are minimum required.

SECTION C-C

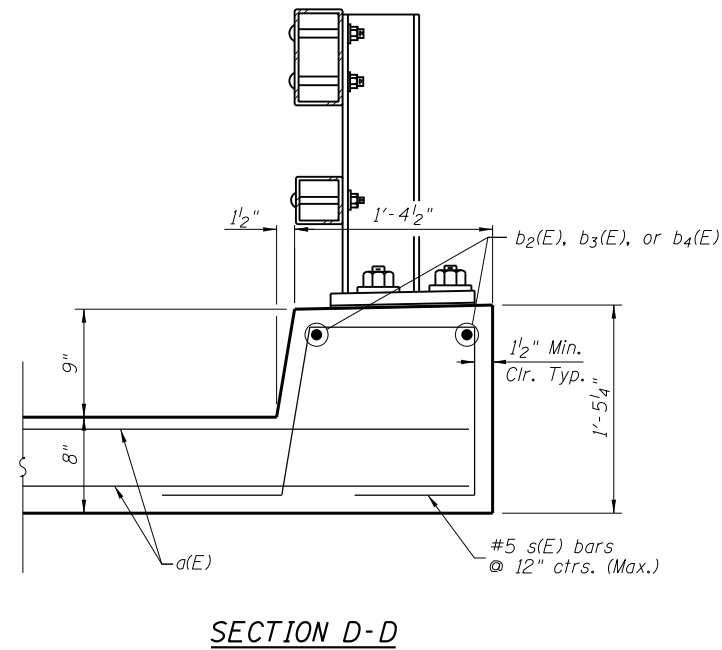
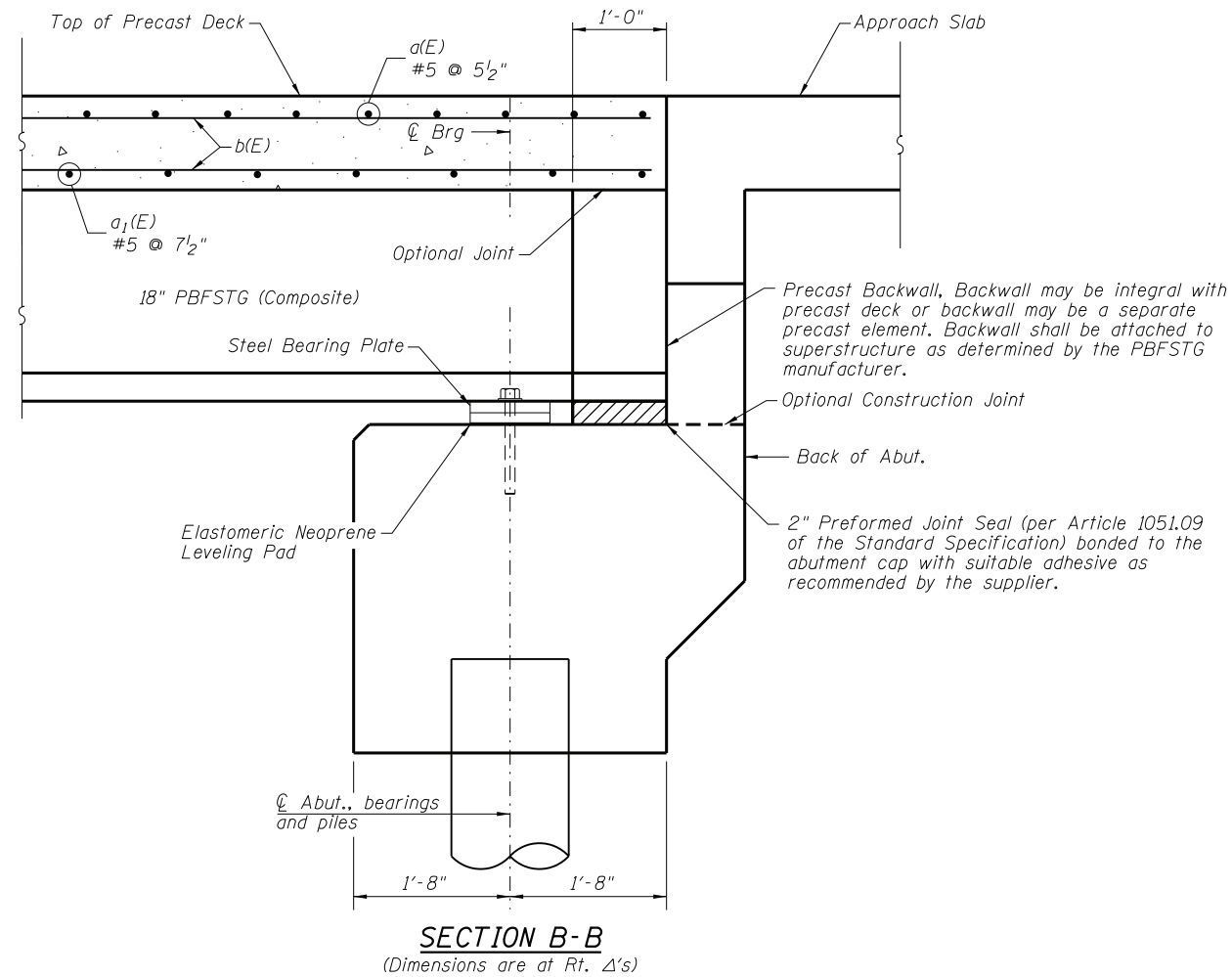

BILL OF MATERIAL

Item	Unit	Quantity
Bridge Deck Grooving	Sq. Yd.	626
Protective Coat	Sq. Yd.	738
Reinforcement Bars, Epoxy Coated	Pound	44,890 *
Erecting Superstructure	Sq. Ft.	6175
Polymer Modified Cement Mortar	Sq. Ft.	692

* For information only. Not included in Total Bill of Materials or Summary of Quantities

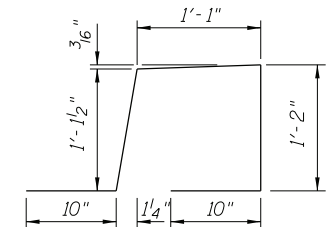

BAR s(E)

FILE NAME = R:\P\J\County\7164 Whiteside Co - Dixon Ave Bridge\CADD\CADD.Structural\17-7164-Super_Des.dgn

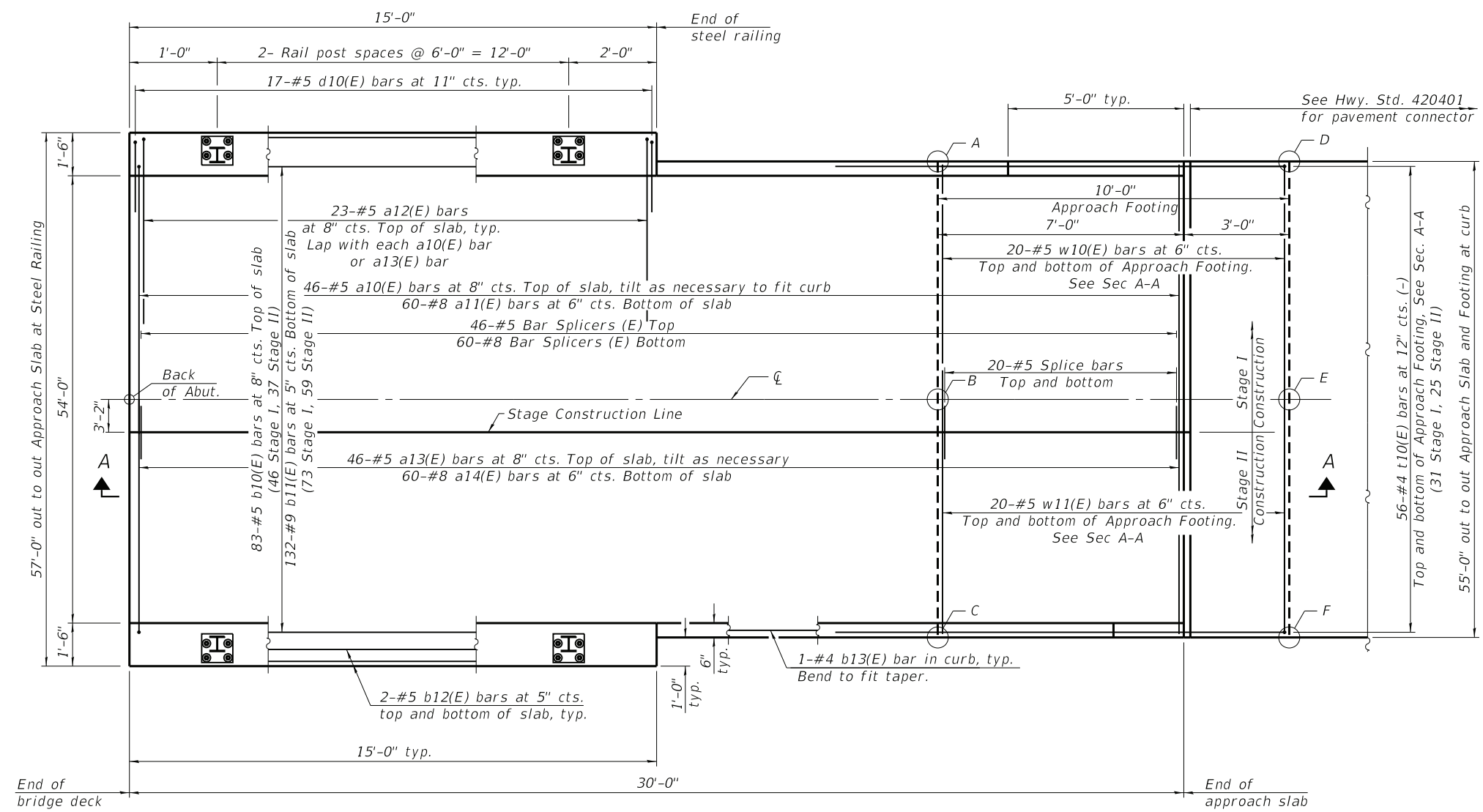

TOP AND BOTTOM ELEVATIONS FOR APPROACH FOOTING

West Approach			East Approach		
Point/Location	Top	Bottom	Point/Location	Top	Bottom
A -	643.02	642.19	A -	643.06	642.23
B -	643.45	642.19	B -	643.47	642.23
C -	643.62	642.19	C -	643.06	642.23
D -	642.98	642.15	D -	643.62	642.19
E -	643.39	642.15	E -	643.43	642.19
F -	642.98	642.15	F -	643.02	642.19

PLAN

(East approach slab shown; West approach slab similar by 180° rotation)

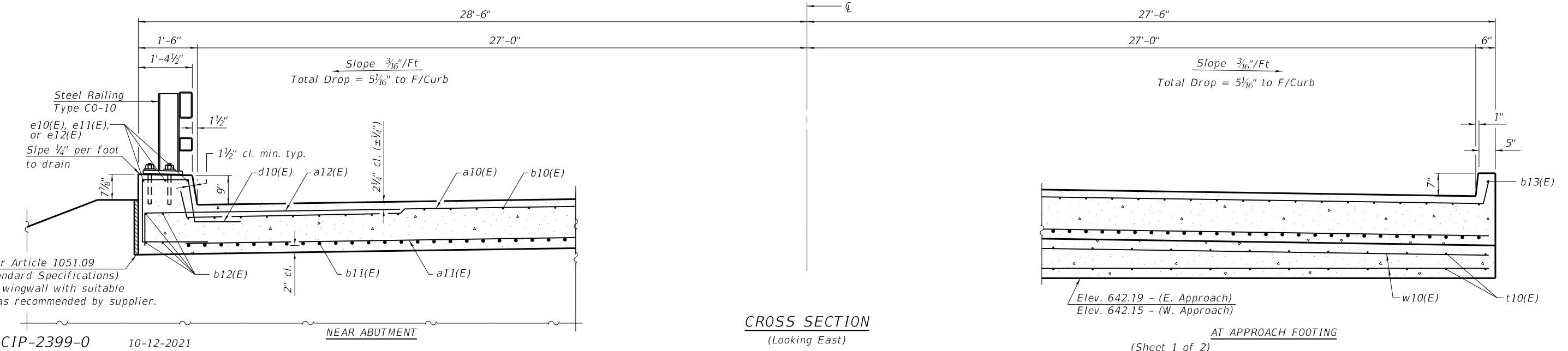

CROSS SECTION

(Looking East)

AT APPROACH FOOTING

(Sheet 1 of 2)

FILE NAME = R:\P\J\County\7164 Whiteside Co - Dixon Ave Bridge\CADD\CADD.Structural\...Erecting Set\1B-7164-Appr.1.dgn

BAIA-CIP-2399-0 10-12-2021



USER NAME = jmadara	DESIGNED KEB	REVISED -
PLOT TIME = 4:02:03 PM	DRAWN JDM	REVISED -
PLOT SCALE = 1.0000' / in.	CHECKED JMB	REVISED -
PLOT DATE = 2/15/2023	DATE 02/15/2023	REVISED -

**STATE OF ILLINOIS
DEPARTMENT OF TRANSPORTATION**

**BRIDGE APPROACH SLAB DETAILS
STRUCTURE NO. 098-3079**

SHEET NO. 7 OF 16 SHEETS

FAU RTE	SECTION	COUNTY	TOTAL SHEETS	SHEET NO.
5560	17-00228-00-BR	WHITESIDE	39	18
CONTRACT NO. 85734				
ILLINOIS FED. AID PROJECT				

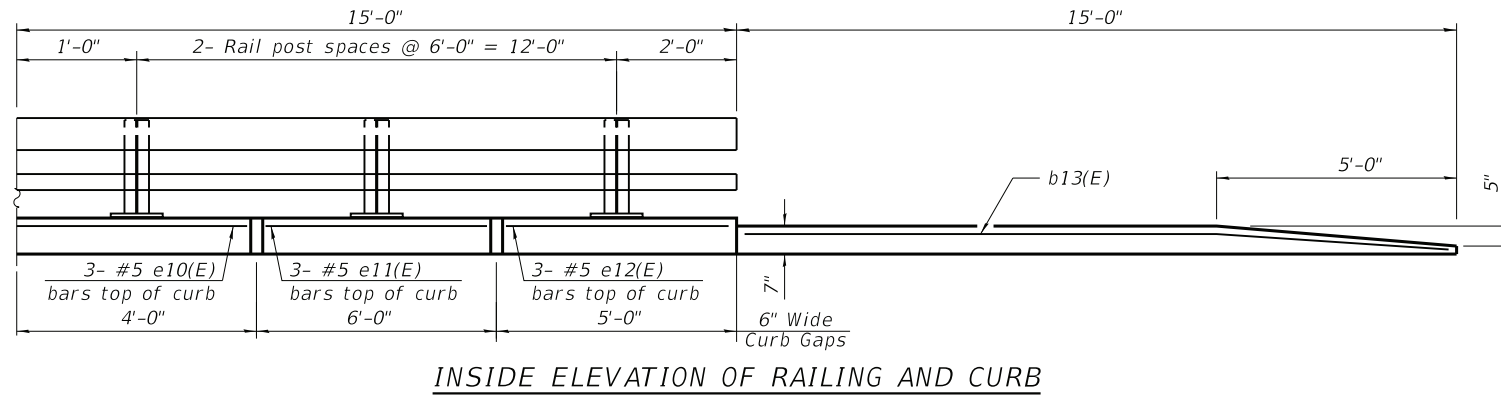

Notes:
 The joint opening shall be adjusted for temperature per Article 520.04 of the Standard Specifications. However, since this detail is for jointless structures, the length of bridge used to calculate the adjustment shall be equal to half the total bridge length plus the length of the bridge approach slab.
 Curb concrete under railing shall be paid for as Concrete Superstructure.
 Approach slab shall be paid for as Concrete Superstructure (Approach Slab).
 Approach footing concrete shall be paid for as Concrete Structures.
 The approach footing maximum applied service bearing pressure (Q_{max}) = 2.0 ksf.
 Cost of excavation for approach footing included with Concrete Structures.
 For Granular Backfill for Structures and drainage treatment details, see sheet 2 of 16.
 For railing details, see sheet 9 of 16.

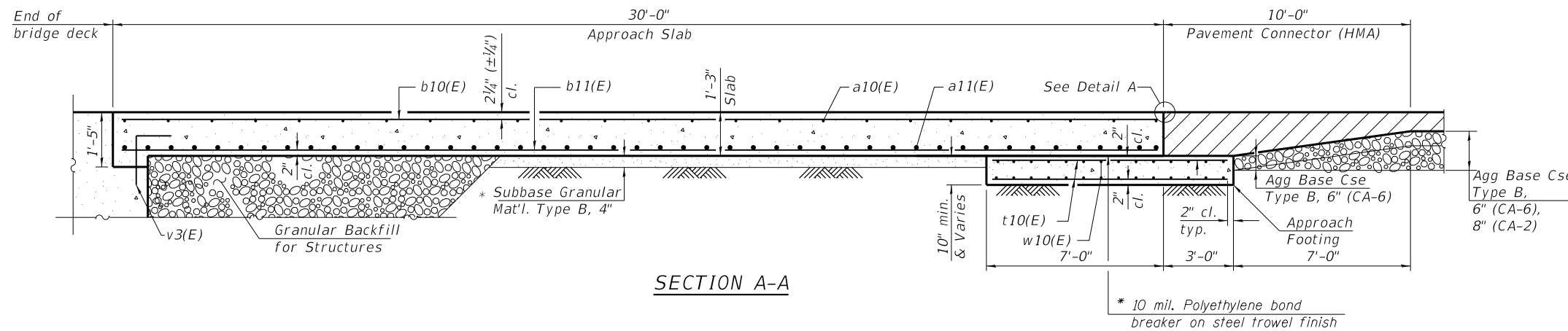

**TWO APPROACHES
 BILL OF MATERIAL**

Bar	No.	Size	Length	Shape	
a10(E)	92	#5	24'-3"	┌───┐	
a11(E)	120	#8	23'-8"	┌───┐	
a12(E)	92	#5	7'-4"	┌───┐	
a13(E)	92	#5	31'-3"	┌───┐	
a14(E)	120	#8	30'-8"	┌───┐	
b10(E)	166	#5	29'-8"	┌───┐	
b11(E)	264	#9	29'-8"	┌───┐	
b12(E)	16	#5	14'-8"	┌───┐	
b13(E)	4	#4	14'-8"	┌───┐	
d10(E)	68	#5	6'-8"	└─┘	
e10(E)	12	#5	3'-5"	┌───┐	
e11(E)	12	#5	5'-2"	┌───┐	
e12(E)	12	#5	4'-5"	┌───┐	
t10(E)	224	#4	9'-8"	┌───┐	
w10(E)	80	#5	23'-8"	┌───┐	
w11(E)	80	#5	30'-8"	┌───┐	
Concrete Superstructure				Cu. Yd.	2.2
Concrete Superstructure (Approach Slab)				Cu. Yd.	156.3
Concrete Structures				Cu. Yd.	42.5
Reinforcement Bars, Epoxy Coated				Pound	62,100
Bar Splicers				Each	0

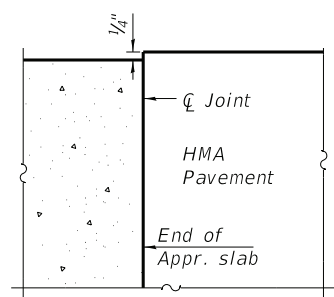

DETAIL A

* Cost included with Concrete Superstructure (Approach Slab).

** Per manufacturer recommendations

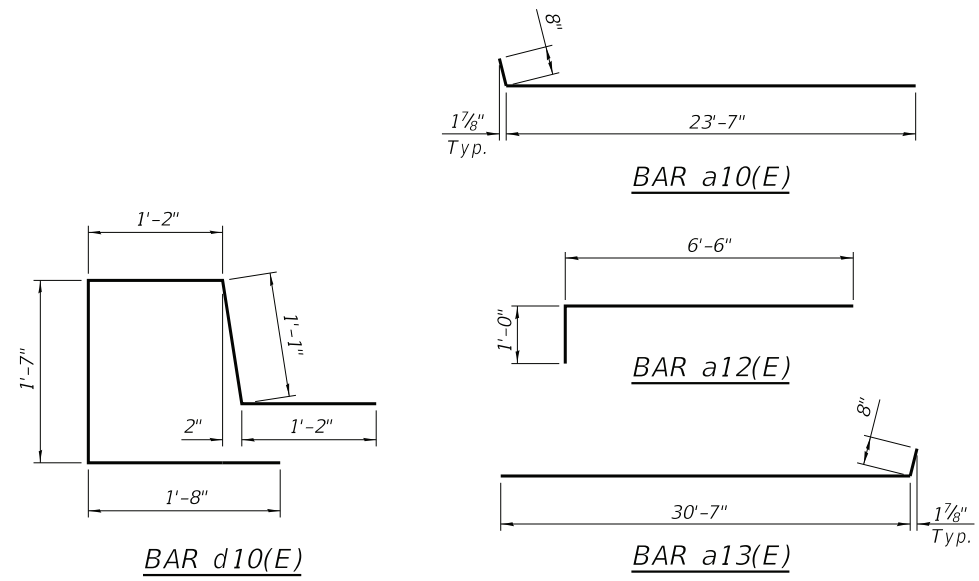

(Sheet 2 of 2)

FILE NAME = R:\P\J\County\7164 Whiteside Co - Dixon Ave Bridge\CADD\CADD_Structure\1_Erecting_Set\9-7164-Appr_2.dgn

BA-CIP-2399-0

2-17-2017

CHASTAIN & ASSOCIATES LLC
 CONSULTING ENGINEERS
 184-001397

USER NAME = jmadara	DESIGNED KEB	REVISED -
PLOT TIME = 4:13:24 PM	DRAWN JDM	REVISED -
PLOT SCALE = 1.0000' / 1"	CHECKED JMB	REVISED -
PLOT DATE = 2/15/2023	DATE 02/15/2023	REVISED -

**STATE OF ILLINOIS
 DEPARTMENT OF TRANSPORTATION**

**BRIDGE APPROACH SLAB DETAILS
 STRUCTURE NO. 098-3079**

SHEET NO. 8 OF 16 SHEETS

FAU RTE	SECTION	COUNTY	TOTAL SHEETS	SHEET NO.
5560	17-00228-00-BR	WHITESIDE	39	19
				CONTRACT NO. 85734
ILLINOIS FED. AID PROJECT				

Notes:
 All HSS tubing shall be ASTM A500 grade C.
 All plates shall be AASHTO M270 grade 50.
 All heavy hex nuts shall be according to ASTM A563 grade DH.
 All fully threaded anchor rods shall be ASTM F1554 grade 105.
 The post base plate shall be fastened to the curb snug tight and given an additional 1/8" turn.
 Posts shall not be located closer than 2'-6" to a bridge expansion joint.
 Provide one 1/8" and two 1/16" steel shims for 25% of the posts. Shims shall be similar to base plates in size and holes.
 All steel rail elements shall be galvanized according to Article 509.05 of the Standard Specifications.
 All HSS tubing shall be CVN tested according to Article 1006.34(b) of the Standard Specifications.
 Rail splice inserts may be built out of 2 - 3/8" bent plates in lieu of the 4 plate rail splice inserts shown, provided the outside dimensions are matched.
 All round head bolts shall be ASTM A449.
 The centerline of rail splices shall be placed between 1'-8" to 2'-6" from the centerline of the posts. The free end of the splice tube shall be oriented away from the closest post.

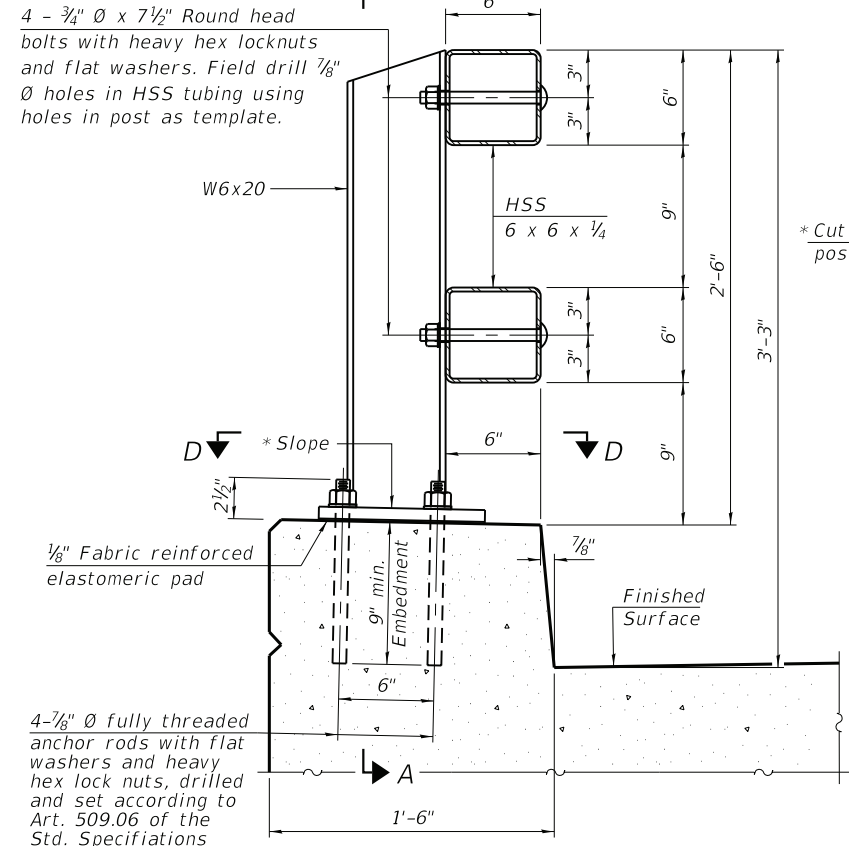

SECTION AT RAIL POST
(New construction)

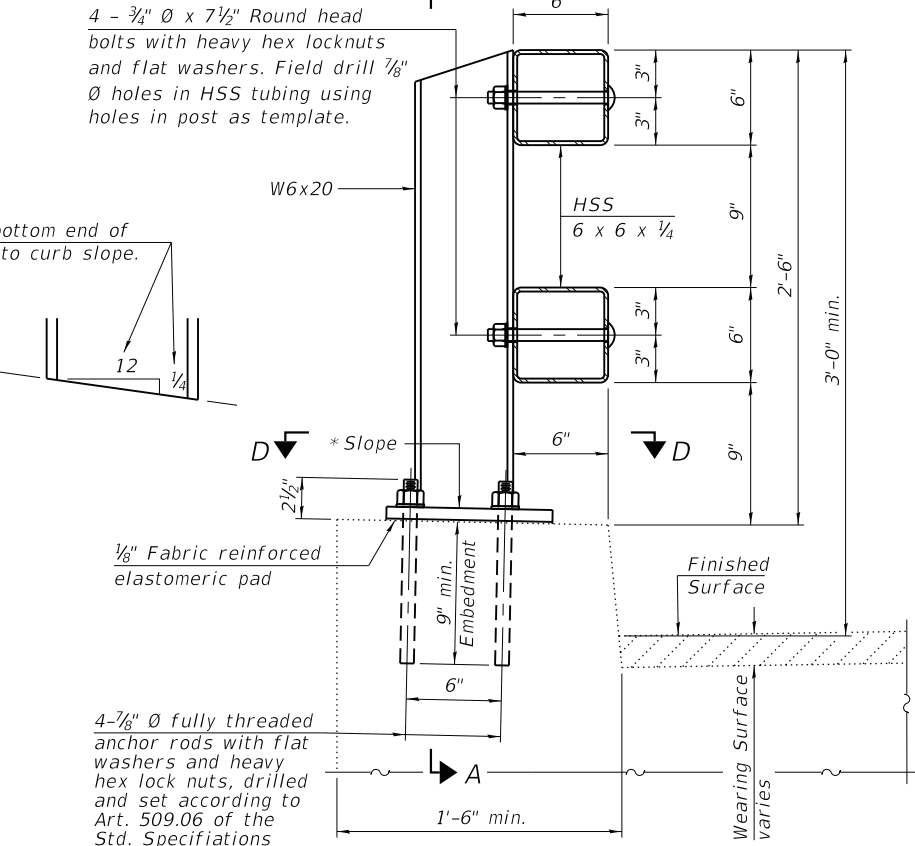

SECTION AT RAIL POST
(Retrofit construction)

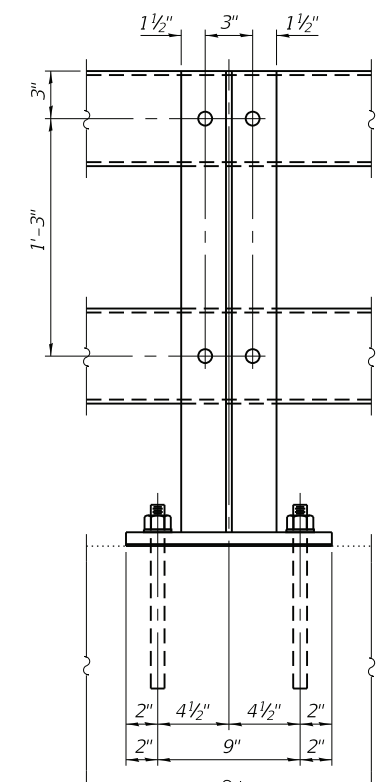

SECTION A-A

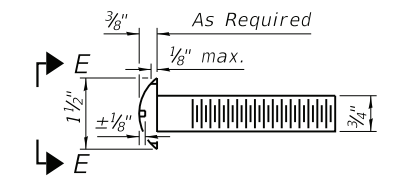

ROUND HEAD BOLT DETAIL

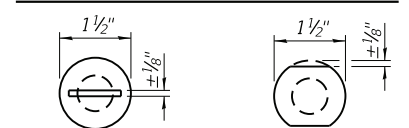

VIEW E-E

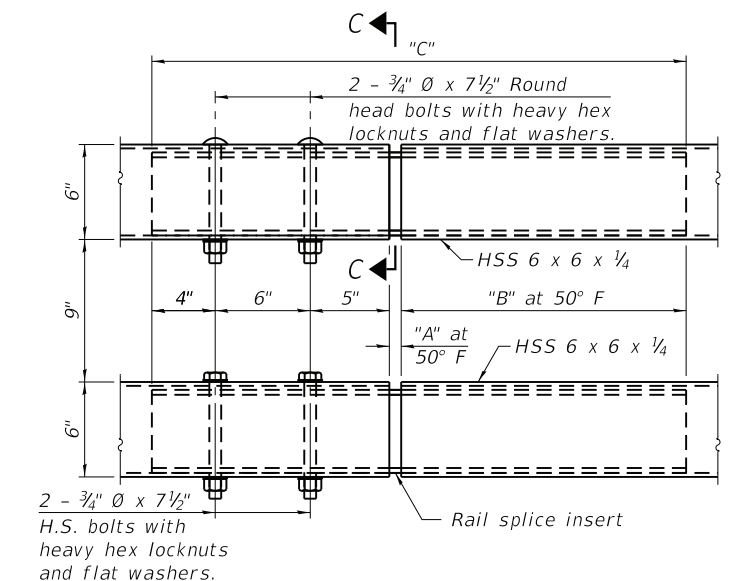

TOP AND BOTTOM RAIL
SPLICE ELEVATION

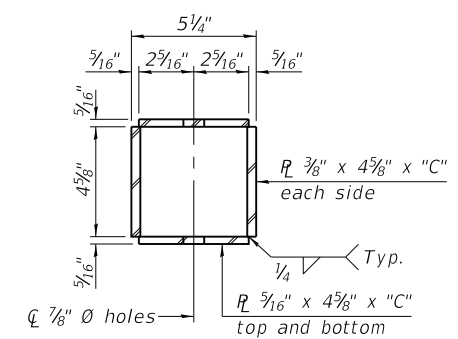

SECTION C-C

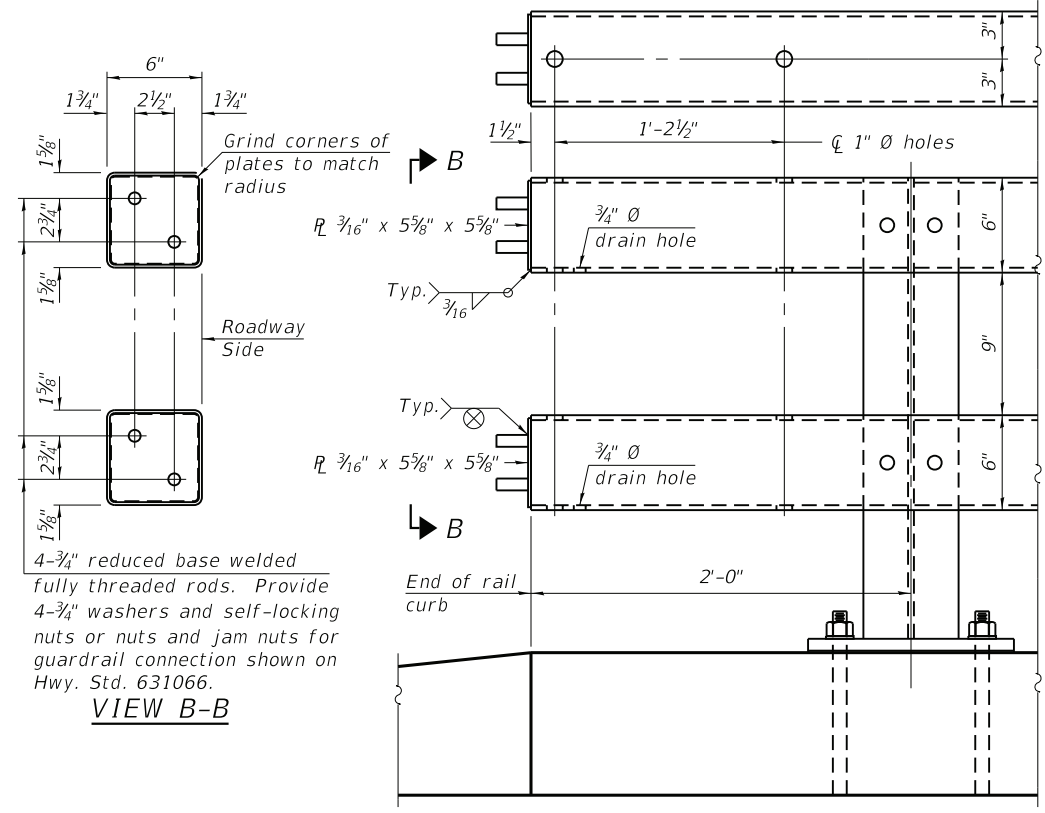

END OF RAIL DETAILS

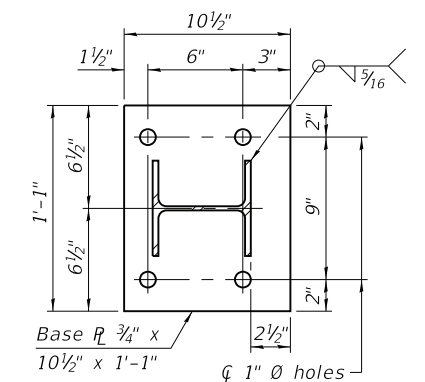

SECTION D-D

SPLICE DIMENSIONS

Location	T	A	B	C
All locs. not over exp. jts.	0	1/2"	1'-6"	2'-9 1/2"
Over Strip Seal Jt.	≤4"	2 1/2"	1'-8"	3'-1 1/2"
Over Finger or Modular Jt.	≤9 1/2"	5 1/2"	1'-10 3/4"	3'-7 1/4"
Over Finger or Modular Jt.	≤15"	8 1/4"	2'-1 1/2"	4'-0 3/4"

T = ; total movement along centerline of roadway at expansion joint. (6'-3" Maximum Post Spacing)

RAILING CRITERIA

MASH 2016 Test Level	4
Railing Weight (plf)	75
Min f'c (psi)	4,500
Post Spacing Range	6'-8" - 10'-0"

R-42 10-12-2021



USER NAME = jmadara
 PLOT TIME = 10:52:42 AM
 PLOT SCALE = 8,0000' / 10"
 PLOT DATE = 2/16/2023

DESIGNED KEB
 DRAWN JDM
 CHECKED JMB
 DATE 02/15/2023

REVISED -
 REVISED -
 REVISED -
 REVISED -

STATE OF ILLINOIS
 DEPARTMENT OF TRANSPORTATION

STEEL RAILING, TYPE CO-10
 STRUCTURE NO. 098-3079

SHEET NO. 9 OF 16 SHEETS

BILL OF MATERIAL

Item	Unit	Quantity
Steel Railing, Type CO-10	Foot	277

FAU RTE	SECTION	COUNTY	TOTAL SHEETS	SHEET NO.
5560	17-00228-00-BR	WHITESIDE	39	20

CONTRACT NO. 85734
 ILLINOIS FED. AID PROJECT

FILE NAME = R:\P\J\County\7164 Whiteside Co - Dixon Ave Bridge\CADD\CADD.Structure\1_Erecting Set\28-7164-Steel Railing.dgn

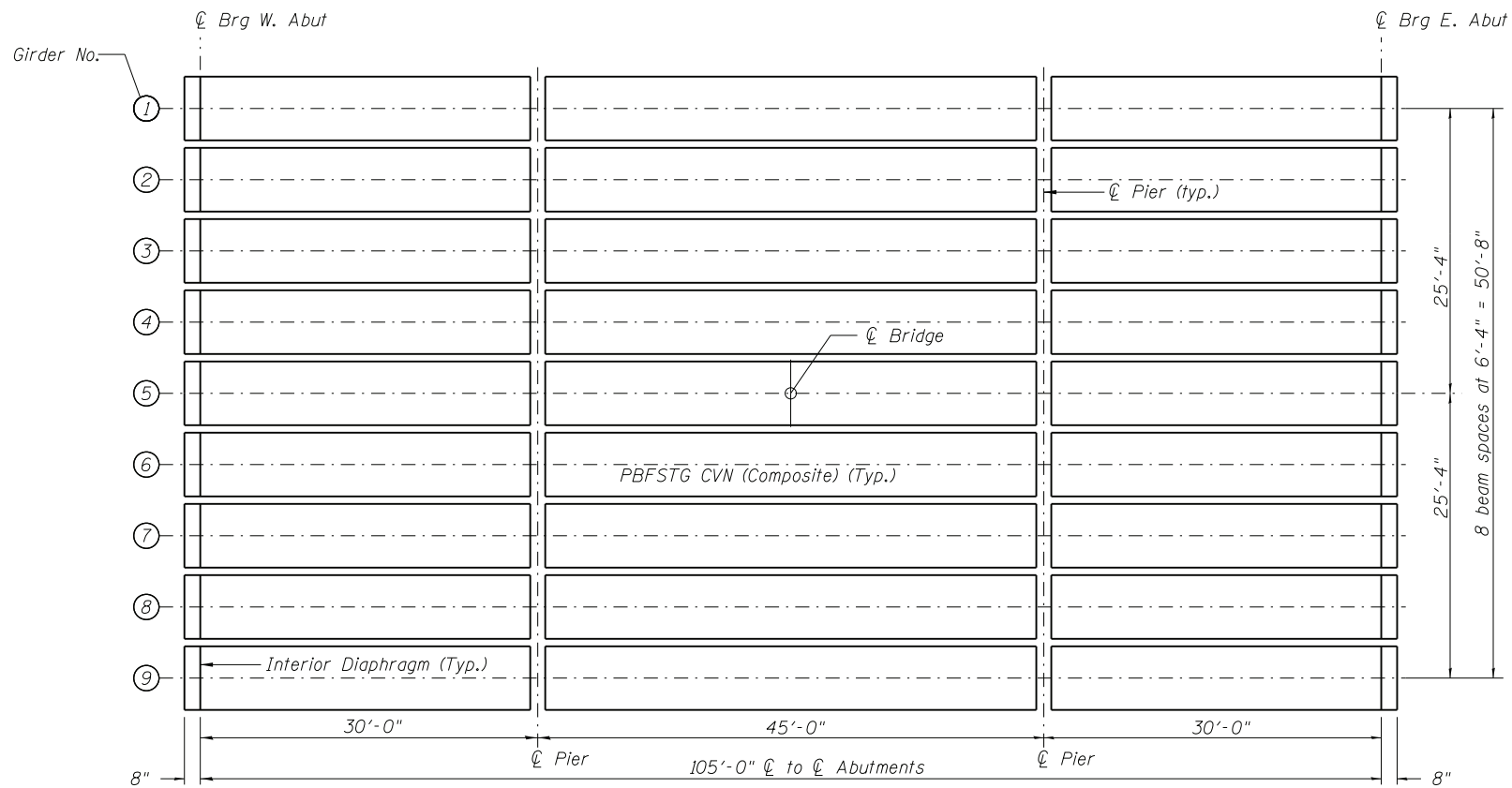

PLAN

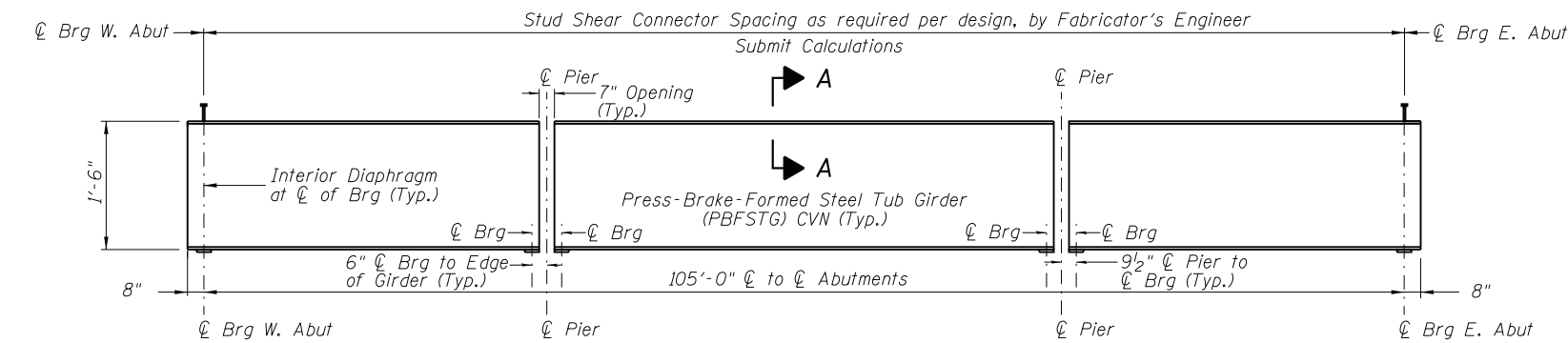

GIRDER ELEVATION

"CVN" denotes Charpy V-Notch impact energy requirements, Zone 2

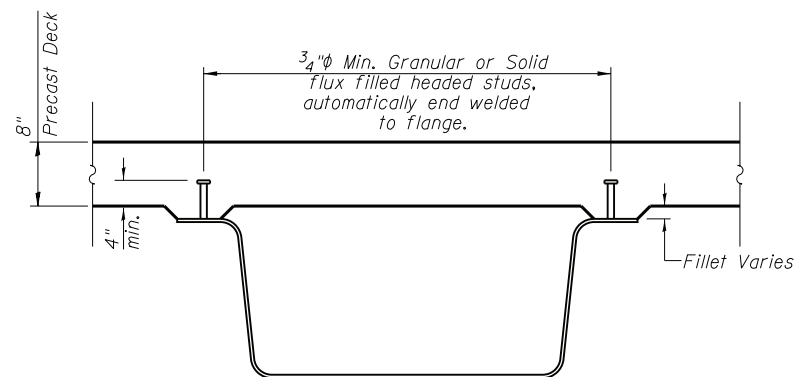

SECTION A-A

NOTES:

All primary members (Tub Girders) shall be A572 grade 65. All secondary members shall be M270 grade 50. For additional structural steel details see sheet 11 of 16. All girders shall be braced for stability during girder installation as required per Manufacturer. "CVN" denotes Charpy-V-Notch impact energy requirements, Zone 2. All Structural Steel and H.S. Bolts shall be galvanized according to the Special Provisions.

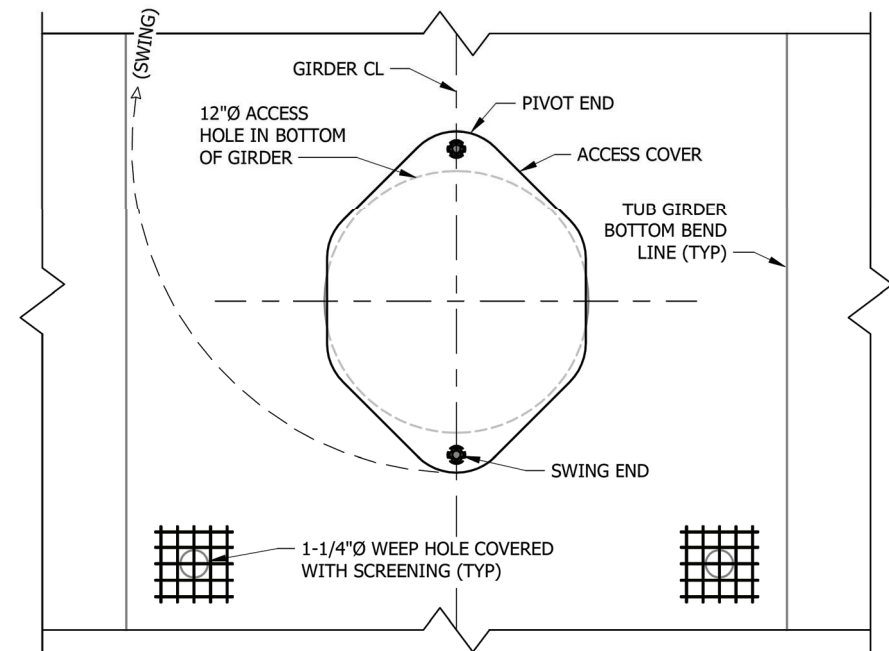

PLAN

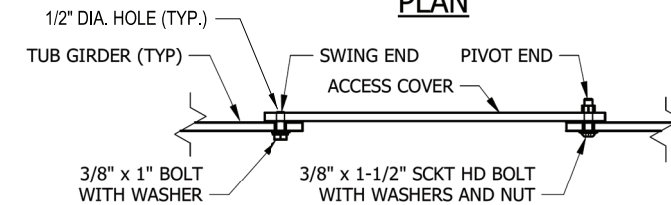

SECTION

INSPECTION HATCH DETAIL

NOTES:

Hatch cover shall be oriented on the inside girder so that the cover plate fits over the hole.

Tighten bolt, but allow for movement.

Every Tub Girder shall have two inspection hatches, one each end at $\pm 3'$ from end of Tub Girder.

Location	ϕ Brg. E. Abut.	ϕ Brg. W. Abut.
Girder 1		
Girder 2		
Girder 3		
Girder 4		
Girder 5		
Girder 6		
Girder 7		
Girder 8		
Girder 9		

TOP OF WEB ELEVATIONS

(For fabrications only)

(Does not include Dead Load Deflection)
Top of Web Elevations to be determined/filled out by Designer/Manufacturer if required.

NOTE:

Top of Web Elevations Table to be filled out by fabricator's engineer & shall provide calculations & information to Chastain & Associates LLC as part of the Shop Drawing Submittals.

FILE NAME = R:\P\J\County\7164 Whiteside Co - Dixon Ave Bridge\CADD\Structural\...Erecting Set\21-7164-Structural Steel.dgn

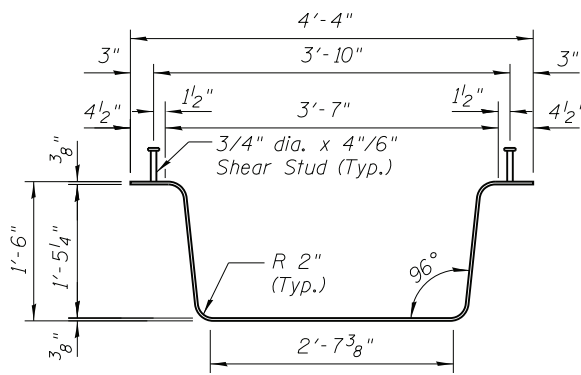

ESTIMATED STEEL SECTION

* Bearing plate width is based on plate layout along the \bar{C} of bearing. Abutment width allows for bearing plate aligned perpendicular to girder. Adjustment is allowed if needed for design of PBFSTG.

Chastain and Associates LLC design includes substructure elements only. Abutment design and details are based on assumed typical reactions and dimensions. Contractor shall verify that final design and details are compatible with the selected superstructure prior to construction. The contractor shall employ a Structural Engineer licensed in the State of Illinois to provide alternate abutment designs as required at no additional cost to the contract.

Notes:
 Two 1/2 in. adjusting shims shall be provided for each bearing in addition to all other plates or shims and places as shown on bearing details.
 Anchor bolts shall be ASTM F1554 all-thread (or an Engineer-approved alternate material) of the grade(s) and diameter(s) specified. The corresponding specified grade of AASHTO M314 anchor bolts may be used in lieu of ASTM F1554.
 Anchor bolts at fixed bearings may be either cast in place or installed in holes drilled after the supported member is in place.
 Drilled and set anchor bolts shall be installed according to Article 521.06 of the Standard Specifications.
 The structural steel plates of the fixed bearings, including pintles (if applicable), shall conform to the requirements of AASHTO M270 Grade 50.
 Anchor bolts at all supports shall be installed as each member is erected unless an equivalent temporary means of lateral restraint is used.
 "CVN" denotes Charpy-V-Notch impact energy requirements, Zone 2.
 All primary members (Tub Girders) shall be A572 Grade 65. All secondary members shall be M270 Grade 50.
 All structural steel and H.S. bolts shall be galvanized according to the Special Provisions.

Fabricator's Structural Engineer shall provide information for all table spaces and shall provide calculations & information to Chastain & Associates LLC as part of the shop drawing submittals.

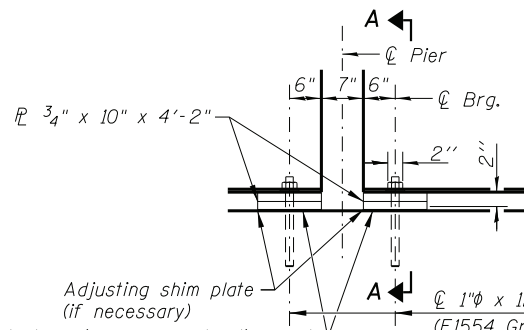

ELEVATION AT PIER

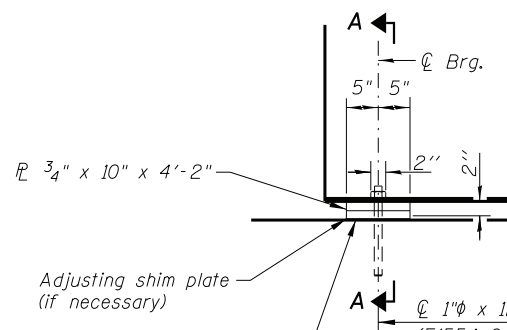

ELEVATION AT ABUTMENT

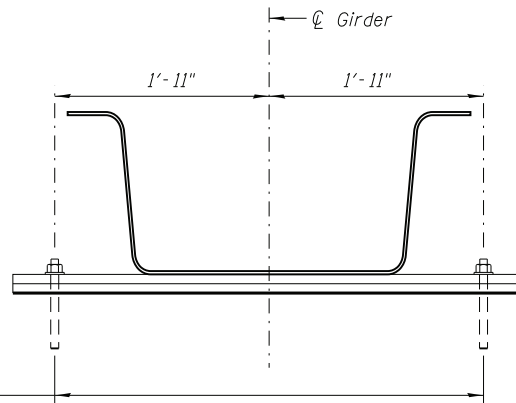

SECTION A-A

(Horiz. dimensions at Rt. Δ 's to \bar{C} Girder)

FIXED BEARINGS AT ABUTMENTS

(18 required)

		0.5 End Span	0.5 Ctr. Span
I_s	(in ⁴)	-	-
I_c (n)	(in ⁴)	-	-
I_c (3n)	(in ⁴)	-	-
S_s	(in ³)	-	-
S_c (n)	(in ³)	-	-
S_c (3n)	(in ³)	-	-
DC1	(k/')	-	-
MDC1	('k)	-	-
DC2	(k/')	-	-
MDC2	('k)	-	-
DW	(k/')	-	-
MDW	('k)	-	-
LLDF		-	-
MLL + IM	('k)	-	-
MU (Strength I)	('k)	-	-
$\phi_f M_n$	('k)	-	-
f_s DC1	(ksi)	-	-
f_s DC2	(ksi)	-	-
f_s DW	(ksi)	-	-
f_s (LL + IM)	(ksi)	-	-
f_s (Service II)	(ksi)	-	-
0.95R _h F _{yf}	(ksi)	-	-
f_s (Total)(Strength I)	(ksi)	-	-
$\phi_f F_n$	(ksi)	-	-
V _f	(k)	-	-

		Abutment		Pier	
		Interior	Exterior	Interior	Exterior
LLDF		-	-	-	-
OCF		-	-	-	-
RDC1	(k)	-	-	-	-
RDC2	(k)	-	-	-	-
RDW	(k)	-	-	-	-
RLL	(k)	-	-	-	-
RIM	(k)	-	-	-	-
RTotal	(k)	-	-	-	-

*** Information to be provided by PBFSTG manufacturer. See Special Provisions.

		Abutment		Pier	
		Interior/Exterior	Interior/Exterior	Interior/Exterior	Interior/Exterior
RDC1	(k)	-	-	-	-
RDC2	(k)	-	-	-	-
RDW	(k)	-	-	-	-
RLL	(k)	-	-	-	-
RIM	(k)	-	-	-	-
RTotal	(k)	-	-	-	-

I_s, S_s : Non-composite moment of inertia and section modulus of the steel section used for computing f_s (Total-Strength I, and Service II) due to non-composite dead loads (in⁴ and in³).
 $I_c(n), S_c(n)$: Composite moment of inertia and section modulus of the steel and deck based upon the modular ratio, "n", used for computing f_s (Total-Strength I, and Service II) in uncracked sections due to short-term composite live loads (in⁴ and in³).
 $I_c(3n), S_c(3n)$: Composite moment of inertia and section modulus of the steel and deck based upon 3 times the modular ratio, "3n", used for computing f_s (Total-Strength I, and Service II) in uncracked sections, due to long-term composite (superimposed) dead loads (in⁴ and in³).
 $I_c(cr), S_c(cr)$: Composite moment of inertia and section modulus of the steel and longitudinal deck reinforcement, used for computing f_s (Total-Strength I and Service II) in cracked sections, due to both short-term composite live loads and long-term composite (superimposed) dead loads (in⁴ and in³).
 DC1: Un-factored non-composite dead load (kips/ft.).
 MDC1: Un-factored moment due to non-composite dead load (kip-ft.).
 DC2: Un-factored long-term composite (superimposed excluding future wearing surface) dead load (kips/ft.).
 MDC2: Un-factored moment due to long-term composite (superimposed excluding future wearing surface) dead load (kip-ft.).
 DW: Un-factored long-term composite (superimposed future wearing surface only) dead load (kips/ft.).
 MDW: Un-factored moment due to long-term composite (superimposed future wearing surface only) dead load (kip-ft.).
 $M_L + IM$: Un-factored live load moment plus dynamic load allowance (impact) (kip-ft.).
 M_u (Strength I): Factored design moment (kip-ft.).
 $1.25 (M_{DC1} + M_{DC2}) + 1.5 M_{DW} + 1.75 M_L + IM$
 $\phi_f M_n$: Compact composite positive moment capacity computed according to Article 6.10.7.1 or non-slender negative moment capacity according to Article A6.1.1 or A6.1.2 (kip-ft.).
 f_s DC1: Un-factored stress at edge of flange for controlling steel flange due to vertical non-composite dead loads as calculated below (ksi).
 M_{DC1} / S_{nc}
 f_s DC2: Un-factored stress at edge of flange for controlling steel flange due to vertical composite dead loads as calculated below (ksi).
 $M_{DC2} / S_c(3n)$ or $M_{DC2} / S_c(cr)$ as applicable.
 f_s DW: Un-factored stress at edge of flange for controlling steel flange due to vertical composite future wearing surface loads as calculated below (ksi).
 $M_{DW} / S_c(3n)$ or $M_{DW} / S_c(cr)$ as applicable.
 f_s (L+IM): Un-factored stress at edge of flange for controlling steel flange due to vertical composite live load plus impact loads as calculated below (ksi).
 $M_L + IM / S_c(n)$ or $M_{DW} / S_c(cr)$ as applicable.
 f_s (Service II): Sum of stresses as computed below (ksi).
 $f_{sDC1} + f_{sDC2} + f_{sDW} + 1.3 f_s (L + IM)$
 0.95R_hF_{yf}: Composite stress capacity for Service II loading according to Article 6.10.4.2 (ksi).
 f_s (Total)(Strength I): Sum of stresses as computed below on non-compact section (ksi).
 $1.25 (f_{sDC1} + f_{sDC2}) + 1.5 f_{sDW} + 1.75 f_s (L + IM)$
 $\phi_f F_n$: Non-Compact composite positive or negative stress capacity for Strength I loading according to Article 6.10.7 or 6.10.8 (ksi).
 V_f : Maximum factored shear range in span computed according to Article 6.10.10.
 LLDF: Live Load Distribution Factor
 OCF: Obtuse Correction Factor

Information is provided on this sheet that is not applicable to Erecting Superstructure

FILE NAME = R:\P\J\County\7164 Whiteside Co - Dixon Ave Bridge\CA00\Structural\Errecting Set\22-7164-Struct-Design



USER NAME = jmadara
 PLOT TIME = 4:15:34 PM
 PLOT SCALE = 8.0000' / 1" =
 PLOT DATE = 2/15/2023

DESIGNED KEB
 DRAWN JDM
 CHECKED JMB
 DATE 02/15/2023

REVISED -
 REVISED -
 REVISED -
 REVISED -

STATE OF ILLINOIS
 DEPARTMENT OF TRANSPORTATION

STRUCTURAL STEEL DETAILS
 STRUCTURE NO. 098-3079

SHEET NO. 11 OF 16 SHEETS

FAU RTE	SECTION	COUNTY	TOTAL SHEETS	SHEET NO.
5560	17-00228-00-BR	WHITESIDE	39	22
CONTRACT NO. 85734				
ILLINOIS FED. AID PROJECT				

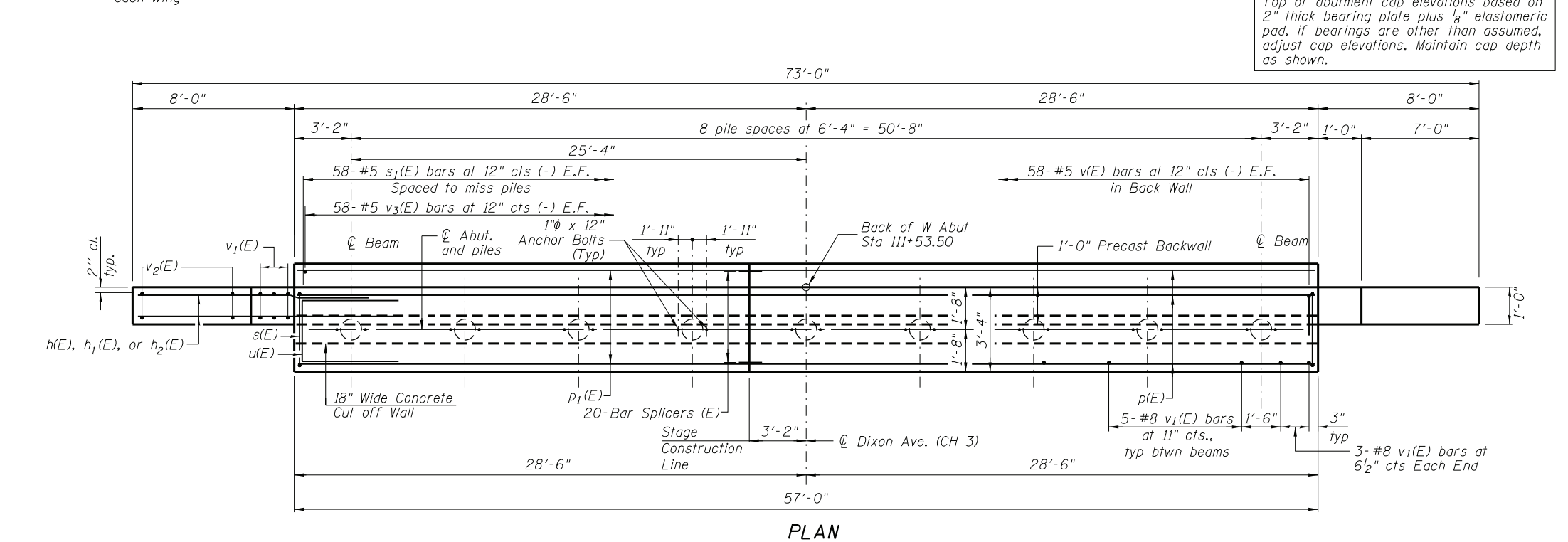
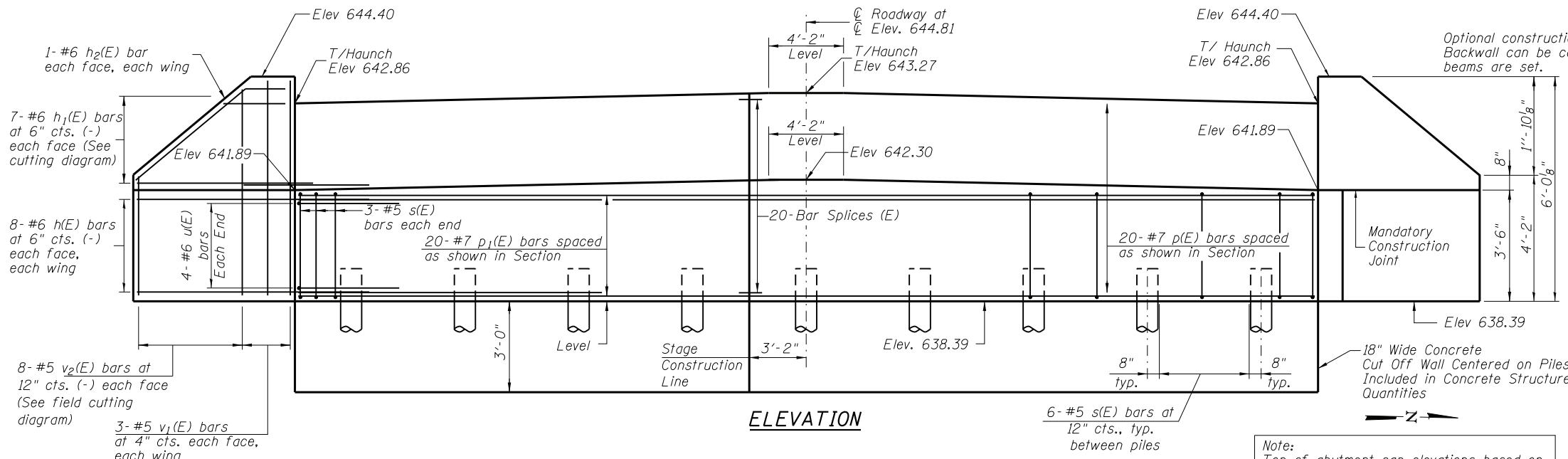

PILE DATA
 Type: Metal Shell - 14"φ x 0.250" walls with Pile Shoes
 Nominal Required Bearing: 211k
 Factored Resistance Available: 116k
 Est. Length: 40 ft.
 No. Production Piles: 8
 No. Test Piles: 1 (W. Abut.)

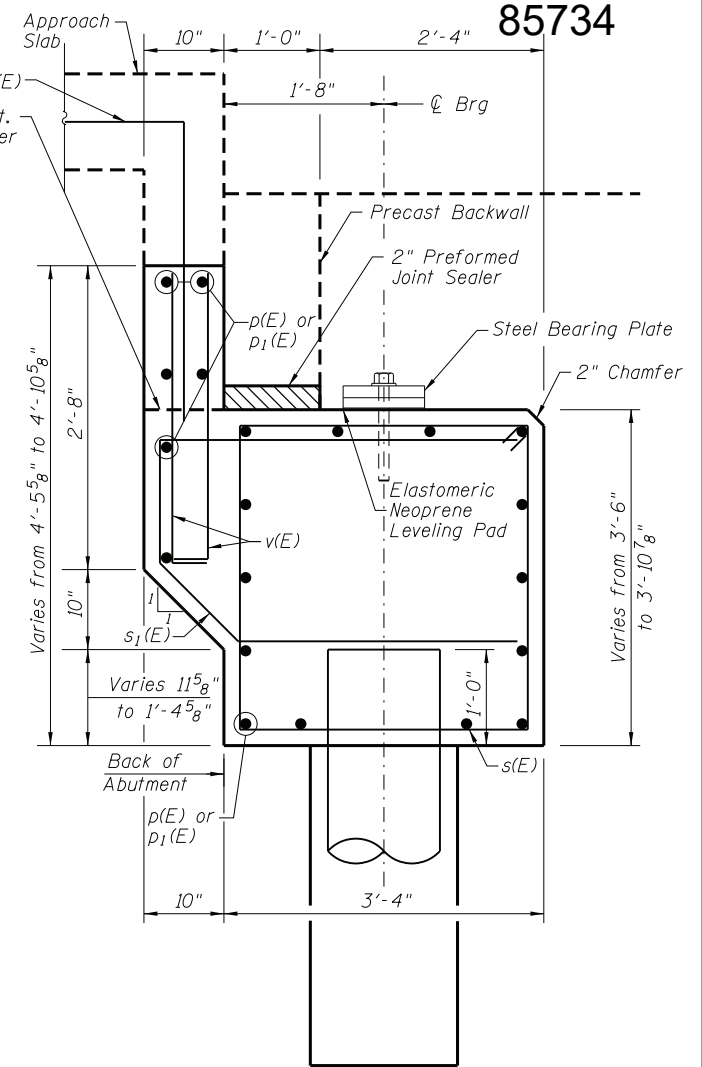
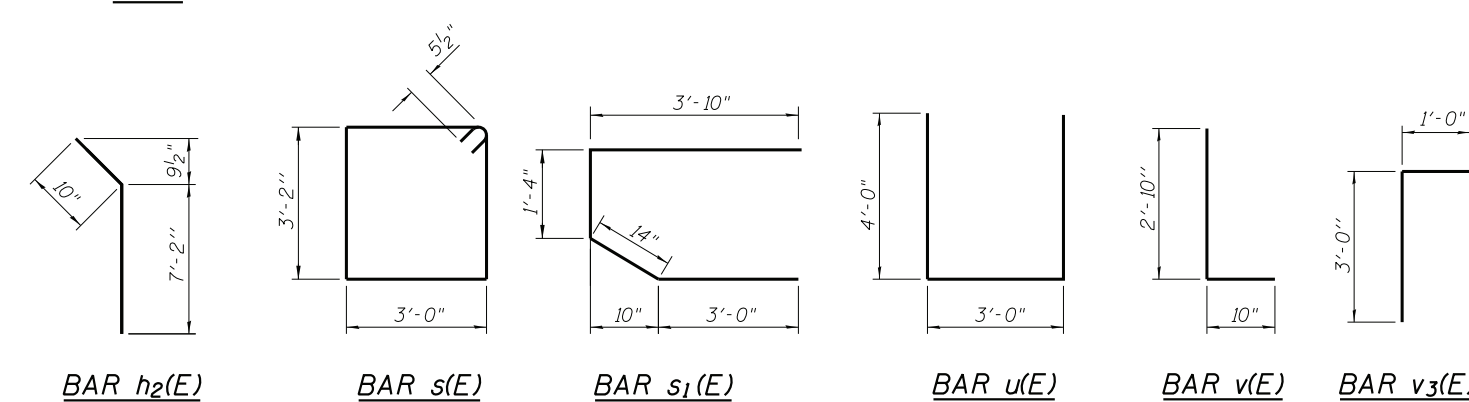
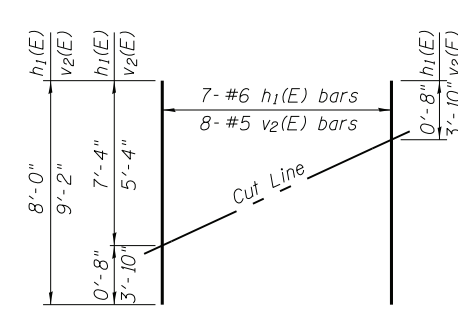

Note:
 Top of abutment cap elevations based on 2" thick bearing plate plus 1/8" elastomeric pad, if bearings are other than assumed, adjust cap elevations. Maintain cap depth as shown.

BILL OF MATERIAL (WEST ABUTMENT)

Bar	No.	Size	Length	Shape
h(E)	32	#6	12'-2"	—
h1(E)	14	#6	8'-0"	—
h2(E)	4	#6	8'-0"	—
p(E)	20	#7	31'-4"	—
p1(E)	20	#7	25'-0"	—
s(E)	54	#5	13'-3"	□
s1(E)	58	#5	9'-4"	□
u(E)	8	#6	11'-0"	□
v(E)	116	#5	3'-8"	L
v1(E)	12	#5	6'-0"	—
v2(E)	16	#5	9'-2"	—
v3(E)	58	#5	4'-0"	—
Structure Excavation			Cu. Yd.	144
Concrete Structures			Cu. Yd.	35.8
Reinforcement Bars, Epoxy Coated			Pound	5460
Furnishing Metal Shell Piles 14"x0.250"			Foot	320
Driving Piles			Foot	320
Test Pile Metal Shells			Each	1
Pile Shoes			Each	9
Bar Splicers			Each	0

For details of piles see sheet 15 of 16.

FILE NAME = R:\P\J\County\7164 Whiteside Co - Dixon Ave Bridge\CADD\CADD.Structural\1.Erecting Set\23-7164-W Abut.dgn



USER NAME = jmadara	DESIGNED KEB	REVISED -
PLOT TIME = 4:17:00 PM	DRAWN JDM	REVISED -
PLOT SCALE = 1/8" = 1'-0"	CHECKED JMB	REVISED -
PLOT DATE = 2/15/2023	DATE 02/15/2023	REVISED -

STATE OF ILLINOIS
 DEPARTMENT OF TRANSPORTATION

WEST ABUTMENT
 STRUCTURE NO. 098-3079

SHEET NO. 12 OF 16 SHEETS

FAU RTE	SECTION	COUNTY	TOTAL SHEETS	SHEET NO.
5560	17-00228-00-BR	WHITESIDE	39	23
CONTRACT NO. 85734				
ILLINOIS FED. AID PROJECT				

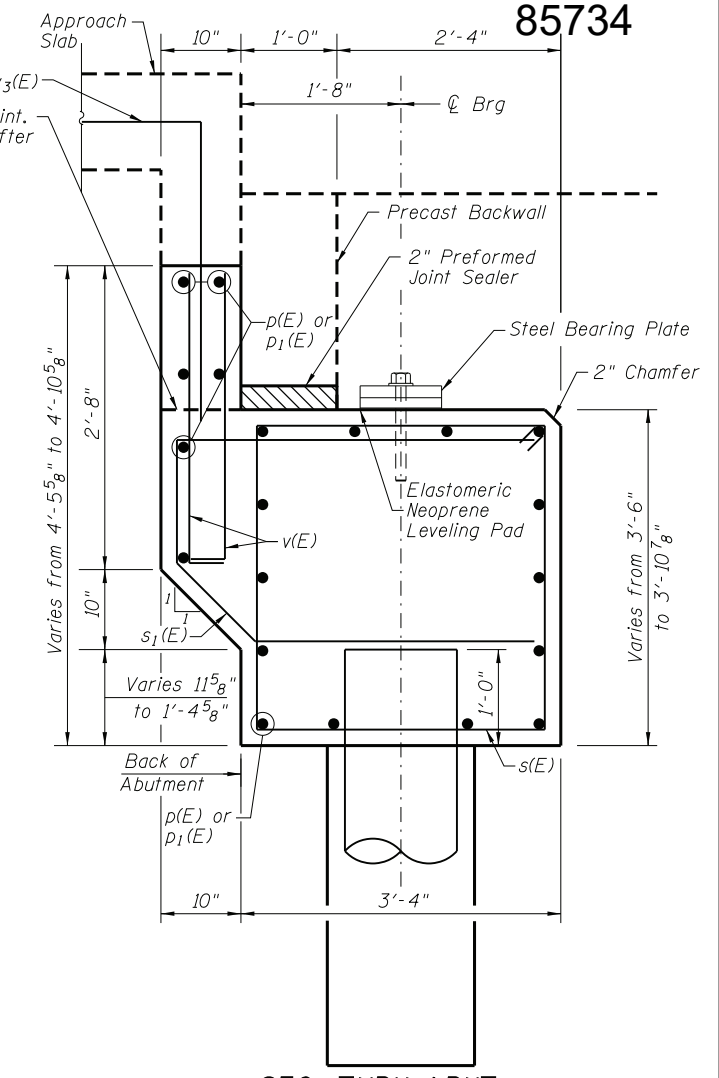
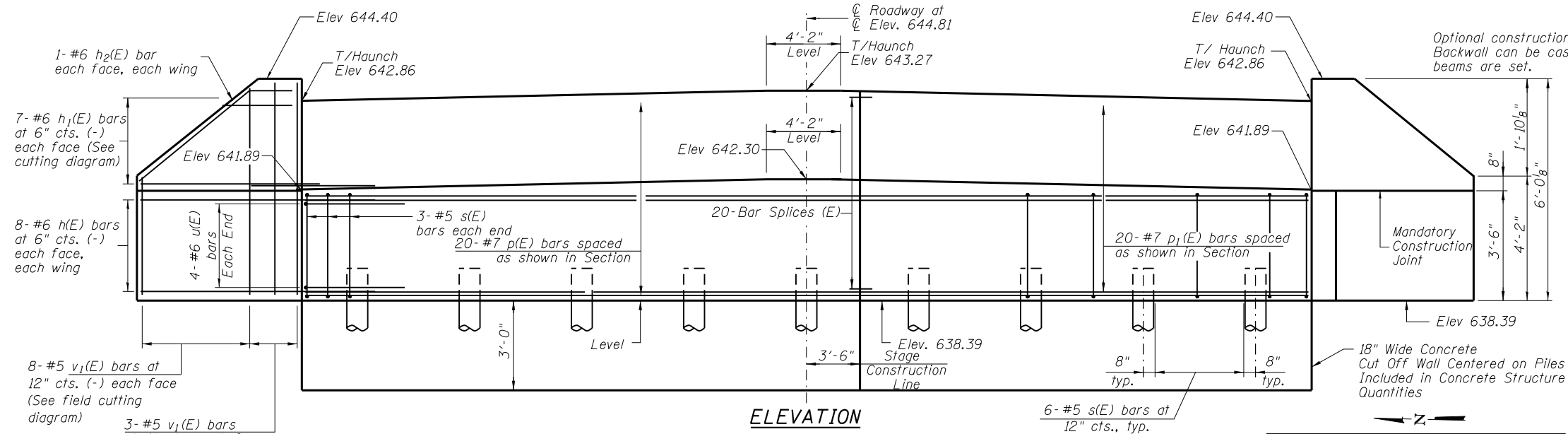

Note:
Top of abutment cap elevations based on 2\"/>

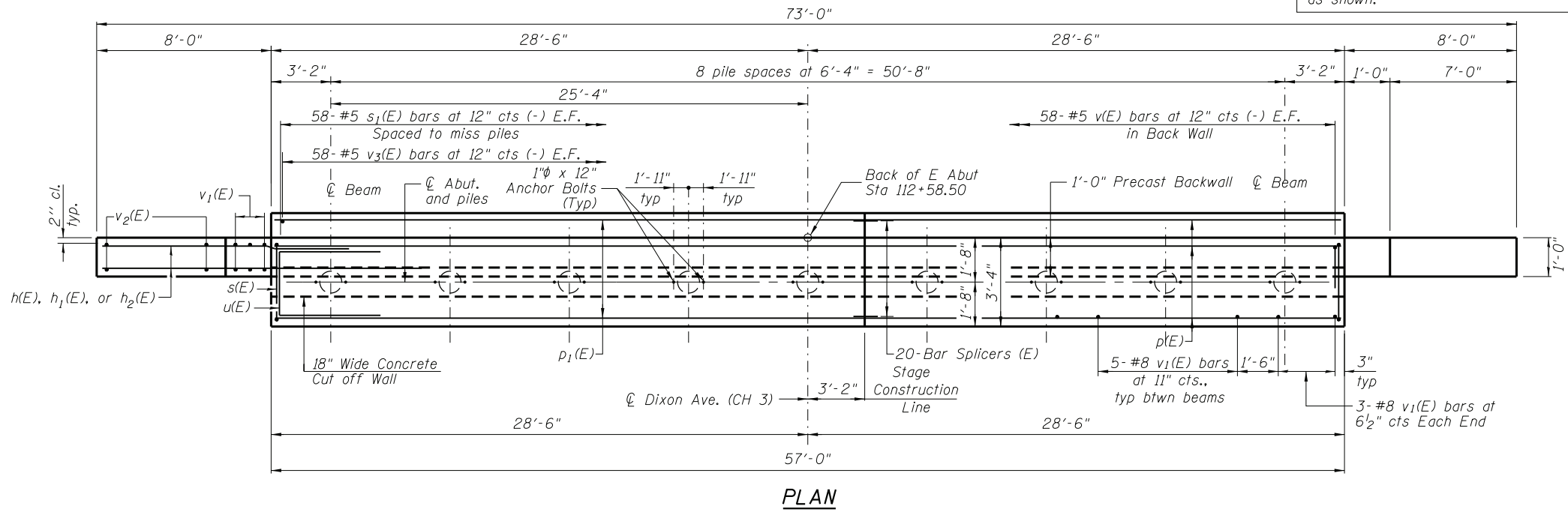

BILL OF MATERIAL (EAST ABUTMENT)

Bar	No.	Size	Length	Shape
h(E)	32	#6	12'-2"	—
h1(E)	14	#6	8'-0"	—
h2(E)	4	#6	8'-0"	—
p(E)	20	#7	31'-4"	—
p1(E)	20	#7	25'-0"	—
s1(E)	54	#5	13'-3"	□
s2(E)	58	#5	9'-4"	□
u(E)	8	#6	11'-0"	□
v(E)	116	#5	3'-8"	L
v1(E)	12	#5	6'-0"	—
v2(E)	16	#5	9'-2"	—
v3(E)	58	#5	4'-0"	—
Structure Excavation			Cu. Yd.	144
Concrete Structures			Cu. Yd.	35.8
Reinforcement Bars, Epoxy Coated			Pound	5460
Furnishing Metal Shell Piles 14"x0.250"			Foot	160
Driving Piles			Foot	160
Test Pile Metal Shells			Each	1
Pile Shoes			Each	9

For details of piles see sheet 15 of 16.

PILE DATA

Type: Metal Shell - 14"φ x 0.250" walls with Pile Shoes
 Nominal Required Bearing: 211k
 Factored Resistance Available: 116k
 Est. Length: 20 ft.
 No. Production Piles: 8
 No. Test Piles: 1 (E. Abut.)

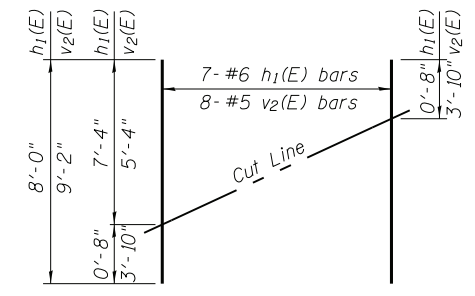

FIELD CUTTING DIAGRAM

Order h1(E) and v3(E) bars full length. Cut as shown and use remainder of bars in opposite face.

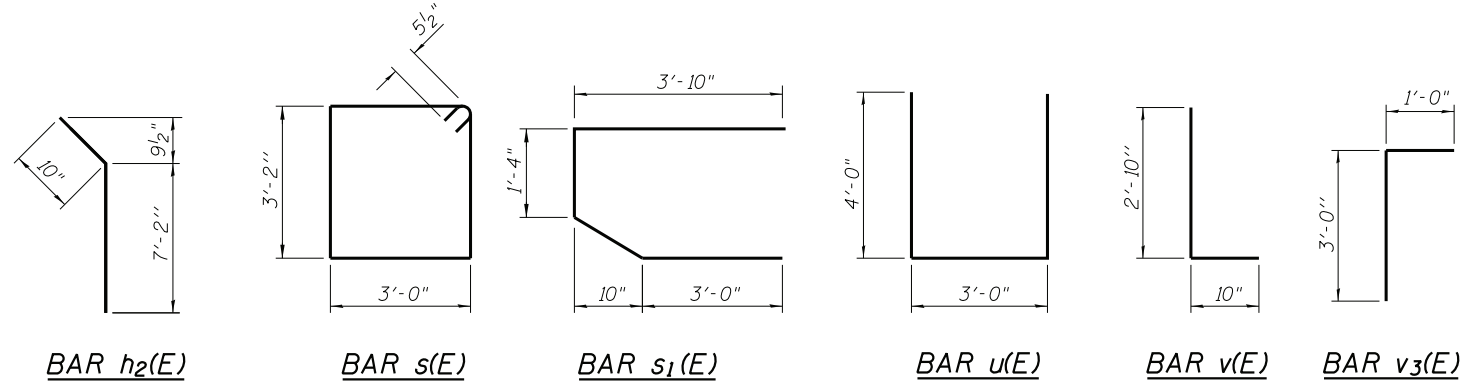

FILE NAME = R:\P\J\County\7164 Whiteside Co - Dixon Ave Bridge\CADD\CADD.Structural\1_Erecting Set\24-7164-E Abut.dgn

CHASTAIN & ASSOCIATES LLC
 CONSULTING ENGINEERS
 184-001397

USER NAME = jmadara	DESIGNED KEB	REVISED -
PLOT TIME = 4:18:04 PM	DRAWN JDM	REVISED -
PLOT SCALE = 1/8" = 1' - 0"	CHECKED JMB	REVISED -
PLOT DATE = 2/15/2023	DATE 02/15/2023	REVISED -

STATE OF ILLINOIS
DEPARTMENT OF TRANSPORTATION

EAST ABUTMENT
STRUCTURE NO. 098-3079

SHEET NO. 13 OF 16 SHEETS

FAU RTE	SECTION	COUNTY	TOTAL SHEETS	SHEET NO.
5560	17-00228-00-BR	WHITESIDE	39	24
CONTRACT NO. 85734				
ILLINOIS FED. AID PROJECT				

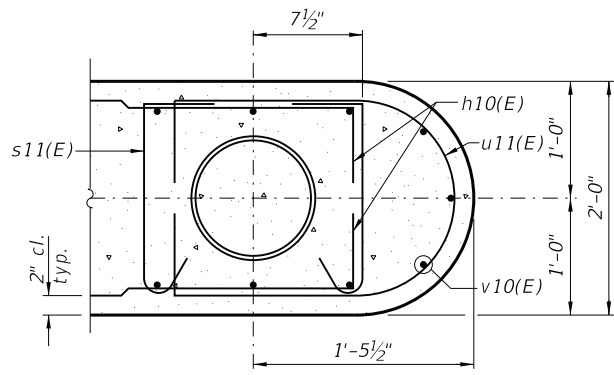

SECTION A-A

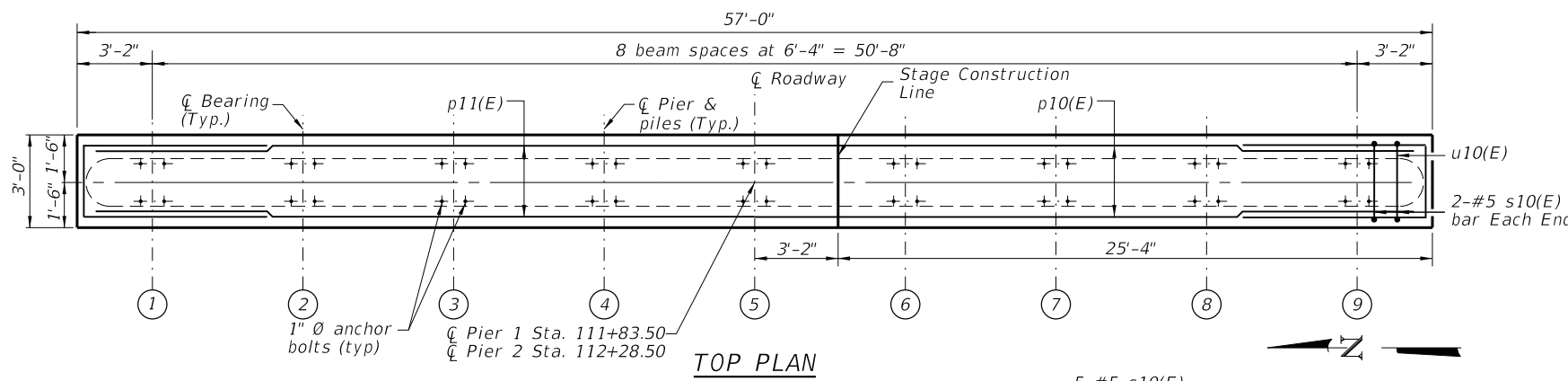

TOP PLAN

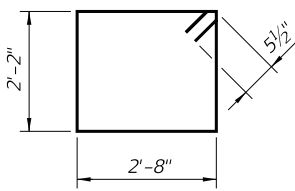

BAR s10(E)

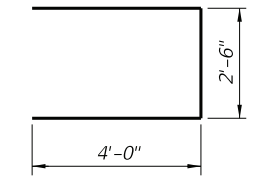

BAR u10(E)

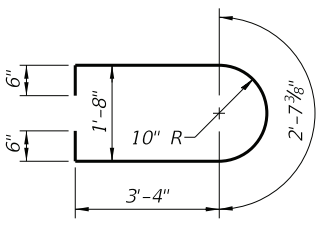

BARS u11(E)

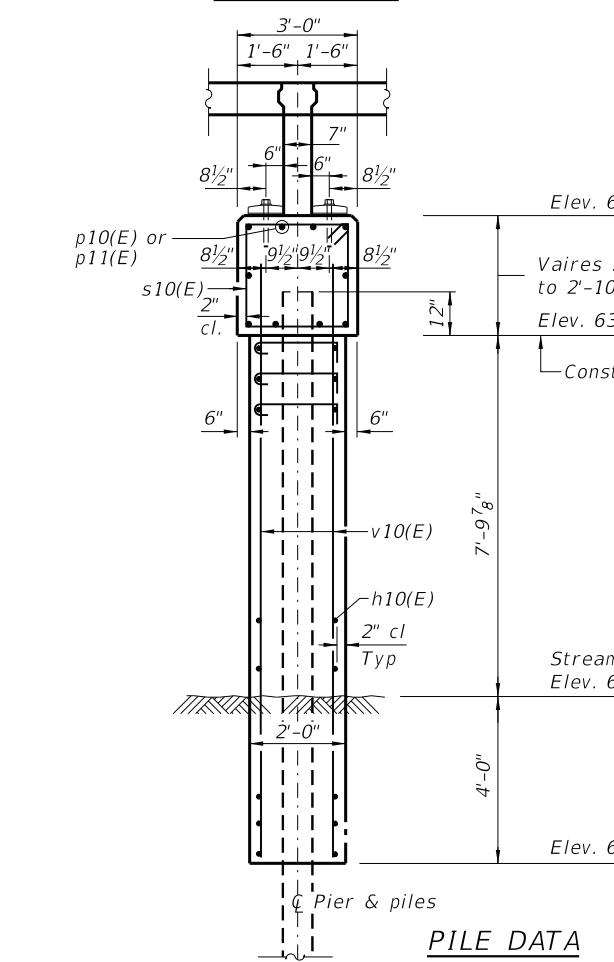

SECTION B-B

PILE DATA
 Type: Metal Shell 14"x0.250" with Pile Shoes
 Nominal Required Bearing: 218 kips
 Factored Resistance Available: 123 kips
 Est. Length: 55' W. Pier, 30' E. Pier
 No. Production Piles: 22
 No. Test Piles: 2 (1 West Pier, 1 East Pier)

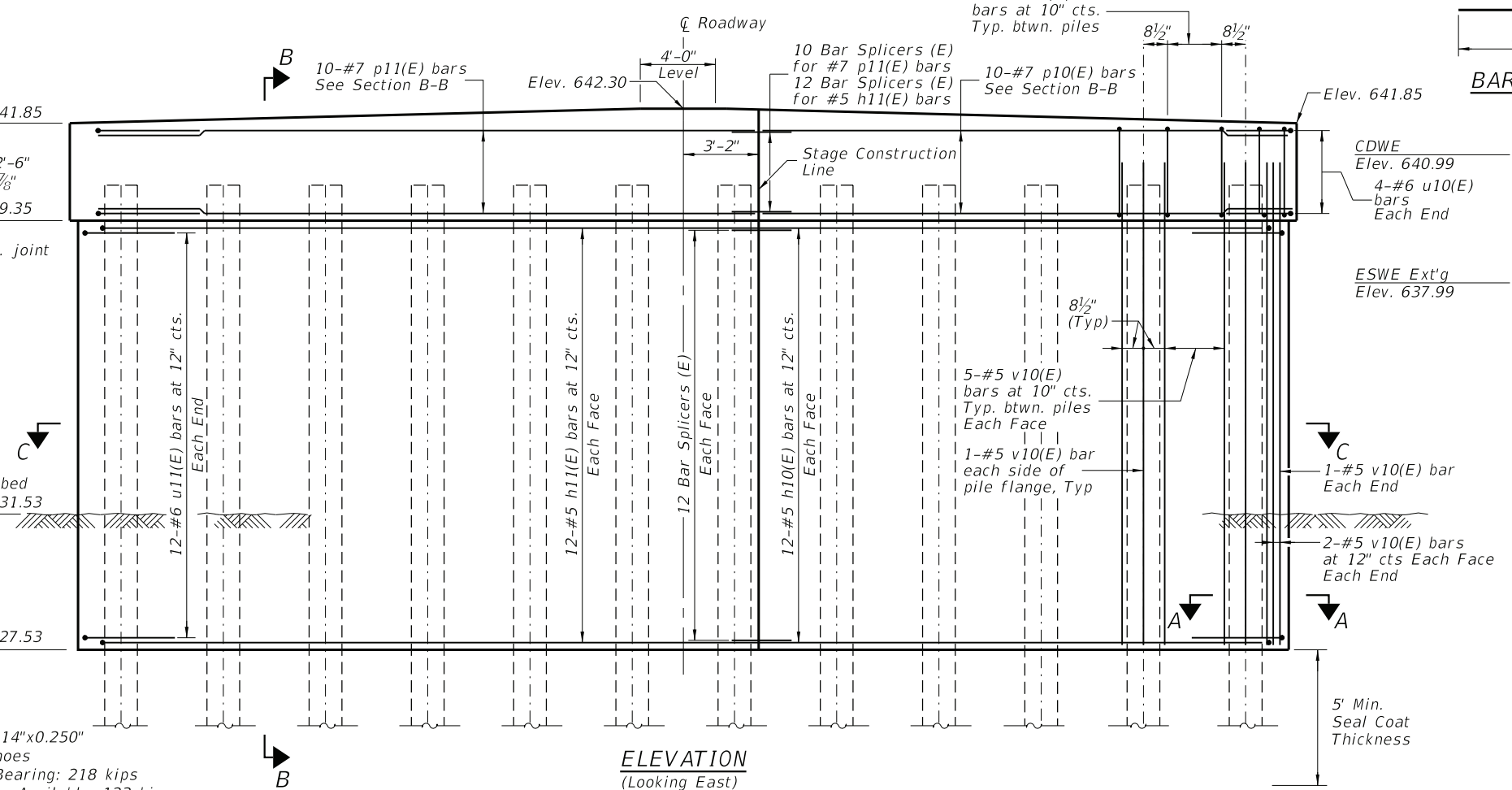

ELEVATION (Looking East)

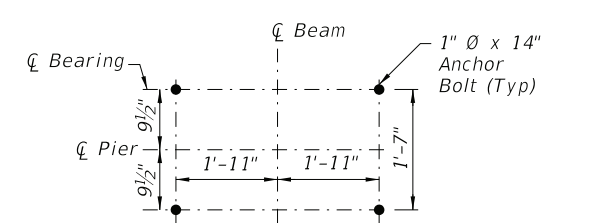

ANCHOR BOLT LAYOUT

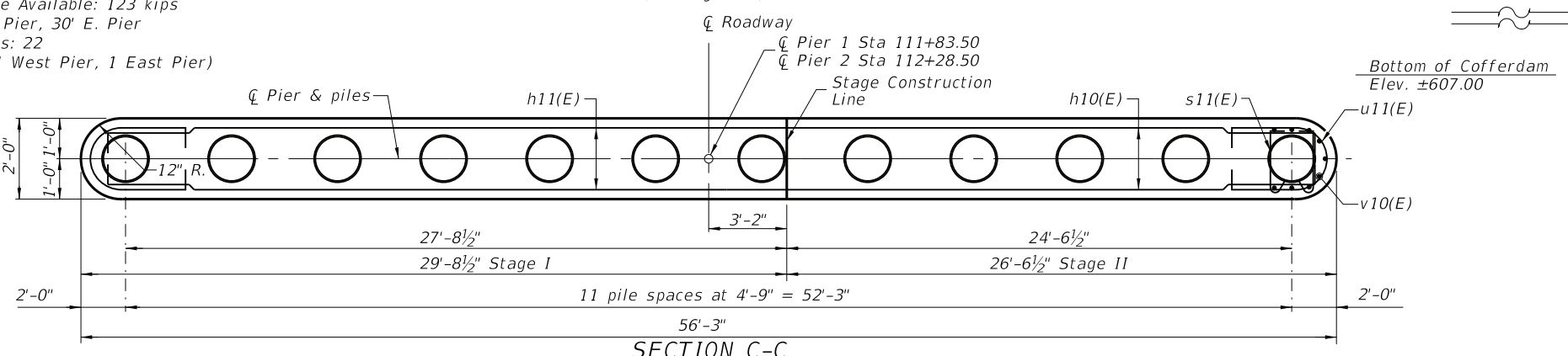

SECTION C-C

BILL OF MATERIAL (2 PIERS)

Bar	No.	Size	Length	Shape
h10(E)	48	#5	23'-3"	—
h11(E)	48	#5	30'-3"	—
p10(E)	20	#7	24'-8"	—
p11(E)	20	#7	31'-8"	—
s10(E)	118	#5	10'-7"	□
u10(E)	16	#7	10'-6"	U
u11(E)	48	#6	10'-4"	U
v10(E)	288	#5	13'-6"	—
Cofferdam Excavation			Cu. Yd.	430
Concrete Structures			Cu. Yd.	144.9
Reinforcement Bars, Epoxy Coated			Pound	11,430
Furnishing Metal Shell Piles, 14"x0.250"			Foot	935
Driving Piles			Foot	935
Test Pile, Metal Shell			Each	2
Pile Shoes			Each	24
Cofferdam (Type 2) (Location 1)			Each	1
Cofferdam (Type 2) (Location 2)			Each	1
Seal Coat Concrete			Cu. Yd.	238
Bar Splicers			Each	0

Notes:
 If a portion of the pier wall or concrete encasement is under water, reinforcement may be placed underwater in forms. Concrete shall be tremied according to Article 503.08 of the Standard Specifications to an elevation of 1'-0" above the water line at the time of construction.
 For details of piles see sheet 15 of 16.
 All edges shall have standard 3/4" chamfer.
 Space reinforcement in cap to miss anchor bolts.

FILE NAME = R:\P\J\County\7164 Whiteside Co - Dixon Ave Bridge\CADD\Structural\Erecting Set\25-7164-Pier.dgn



USER NAME = jmadara
 PLOT TIME = 4:22:04 PM
 PLOT SCALE = 1.0000 / in.
 PLOT DATE = 2/15/2023

DESIGNED KEB
 DRAWN JDM
 CHECKED JMB
 DATE 02/15/2023

REVISED -
 REVISED -
 REVISED -
 REVISED -

STATE OF ILLINOIS
 DEPARTMENT OF TRANSPORTATION

PIER DETAILS
 STRUCTURE NO. 098-3079

SHEET NO. 14 OF 16 SHEETS

FAU RTE	SECTION	COUNTY	TOTAL SHEETS	SHEET NO.
5560	17-00228-00-BR	WHITESIDE	39	25

CONTRACT NO. 85734

ILLINOIS FED. AID PROJECT

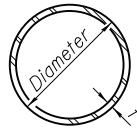

METAL SHELL PILE TABLE

Designation and outside diameter	Wall thickness t	Weight per foot (Lbs./ft.)	Inside volume (yd. 3/ft.)
PP14	0.250"	36.71	0.037

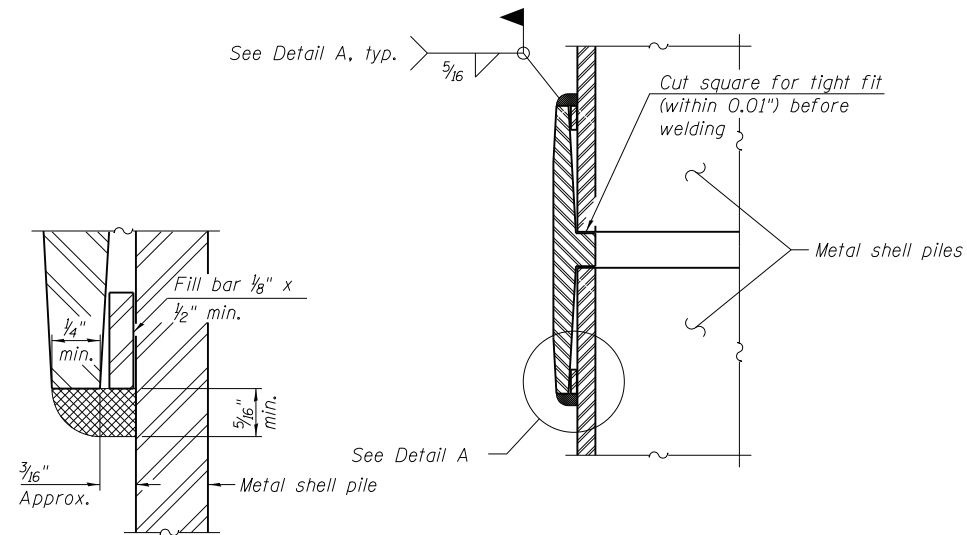

DETAIL A

WELDED COMMERCIAL SPLICE

Notes:
 The 1/8" x 1/2" min. fill bar may be constructed of 2 bars with a 1/8" max. gap between them.
 Pile segments shall be driven to solid contact with splicer before welding.

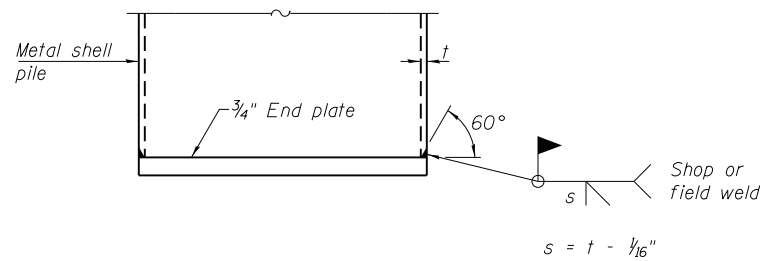

END PLATE ATTACHMENT

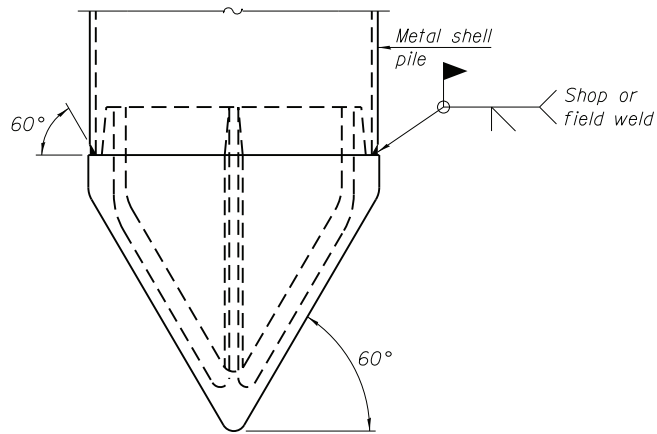

PILE SHOE ATTACHMENT

(When called for on the plans, the Contractor shall furnish metal shell pile shoes consisting of a single piece conical pile point as shown. The pile shoes shall be cast in one piece steel according to either ASTM A 148 Grade 80-50 or AASHTO M 103 Grade 65-35 and shall provide full bearing over the full circumference of the metal shell pile. The pile shoe shall have tapered leads to assure proper alignment and fitting and shall be secured to the pile with a circumferential weld).

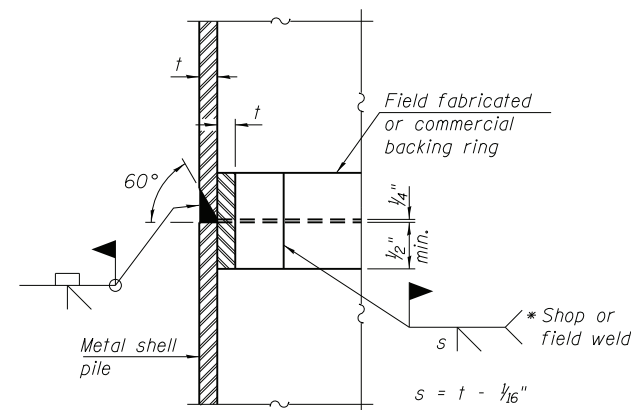

COMPLETE PENETRATION WELD SPLICE

* Field fabricated backing ring may be made from pile shell by removing segment to allow reducing circumference and vertically rejoin with partial joint penetration weld.

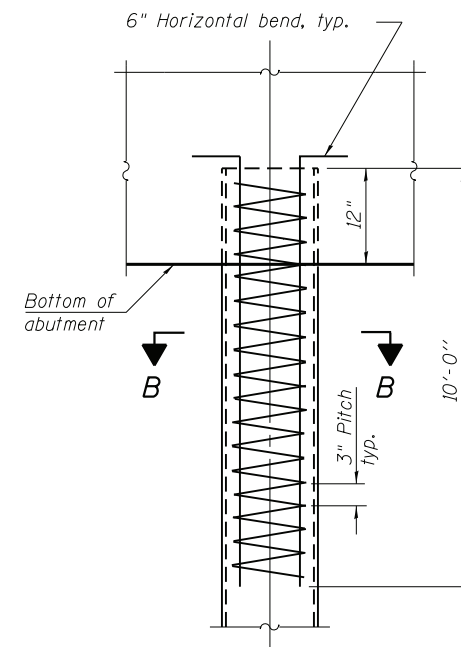

ELEVATION

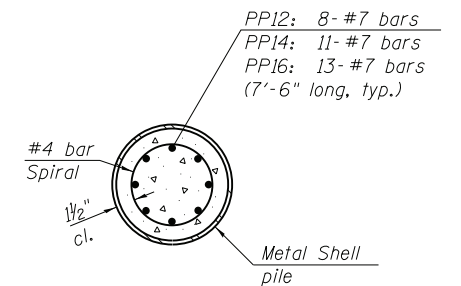

SECTION B-B

REINFORCEMENT AT ABUTMENTS

Note:
 The metal shell piles shall be according to Article 1006.05 of the Standard Specifications.

FILE NAME = R:\P\J\County\7164 Whiteside Co - Dixon Ave Bridge\CADD\Structural\ Erecting Set\25-7164-Pile.sdg

F-MS

1-1-2020



USER NAME = jmadara	DESIGNED KEB	REVISED -
PLOT TIME = 4:23:12 PM	DRAWN JDM	REVISED -
PLOT SCALE = 2.0000' / 1"	CHECKED JMB	REVISED -
PLOT DATE = 2/15/2023	DATE 02/15/2023	REVISED -

**STATE OF ILLINOIS
 DEPARTMENT OF TRANSPORTATION**

**METAL SHELL PILE DETAILS
 STRUCTURE NO. 098-3079**

SHEET NO. 15 OF 16 SHEETS

FAU RTE	SECTION	COUNTY	TOTAL SHEETS	SHEET NO.
5560	17-00228-00-BR	WHITESIDE	39	26
CONTRACT NO. 85734				
ILLINOIS FED. AID PROJECT				

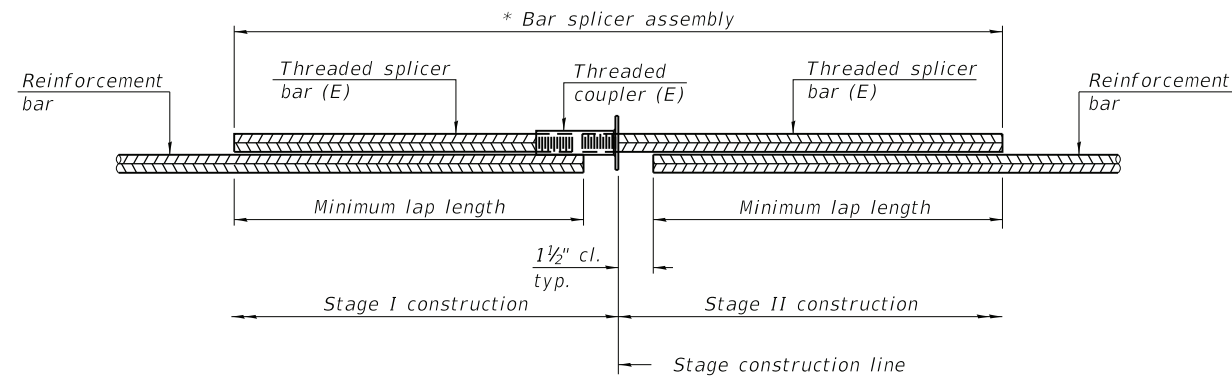

STANDARD BAR SPLICER ASSEMBLY PLAN
 (All components shall be provided from one supplier)

Threaded splicer bar length = min. lap length + 1 1/2" + thread length

* Epoxy not required on Bar Splicer Assembly components used in conjunction with black bars.

Location	Bar size	No. assemblies required	Minimum lap length
East Abut.	#7	20	4'-2"
West Abut.	#7	20	4'-2"
Appr. Slab	#5	92	3'-6"
Appr. Slab	#8	120	5'-0"
Appr. Ftg	#5	80	3'-6"
East Pier	#7	10	4'-2"
West Pier	#5	24	3'-6"
East Pier	#7	10	4'-2"
West Pier	#5	24	3'-6"

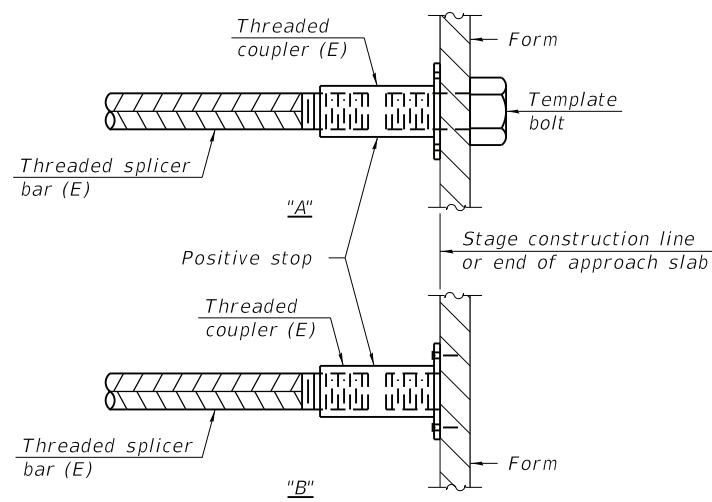

INSTALLATION AND SETTING METHODS

"A" : Set bar splicer assembly by means of a template bolt.
 "B" : Set bar splicer assembly by nailing to wood forms or cementing to steel forms.
 (E) : Indicates epoxy coating.

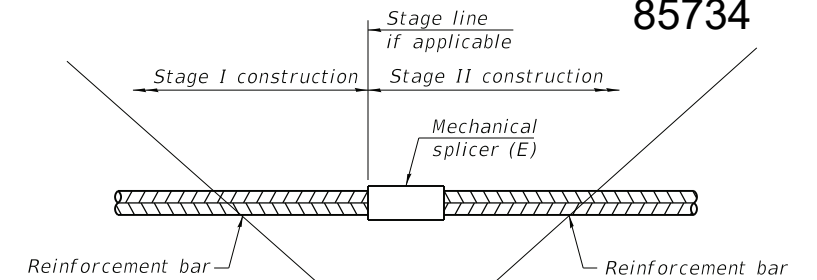

STANDARD MECHANICAL SPLICER

Location	Bar size	No. assemblies required
N/A	N/A	0

Notes:
 Splicer bars shall be deformed with threaded ends and have a minimum 60 ksi yield strength.
 All reinforcement shall be lapped and tied to the splicer bars.
 Bar splicer assemblies shall be epoxy coated according to the requirements for reinforcement bars. See Section 508 of the Standard Specifications.
 See approved list of bar splicer assemblies and mechanical splicers for alternatives.

FILE NAME = R:\P\J\County\7164 Whiteside Co - Dixon Ave Bridge\CADD\CADD.Structural\Freeing Set\27-7164-Splicer Det.dgn

BSD-1

1-1-2020



USER NAME = jmadara	DESIGNED KEB	REVISED -
PLOT TIME = 11:58:14 AM	DRAWN JDM	REVISED -
PLOT SCALE = 2.0000' / 1"	CHECKED JMB	REVISED -
PLOT DATE = 2/27/2023	DATE 02/15/2023	REVISED -

STATE OF ILLINOIS
 DEPARTMENT OF TRANSPORTATION

BAR SPLICER ASSEMBLY AND MECHANICAL SPLICER DETAILS
 STRUCTURE NO. 098-3079

SHEET NO. 16 OF 16 SHEETS

FAU RTE	SECTION	COUNTY	TOTAL SHEETS	SHEET NO.
5560	17-00228-00-BR	WHITESIDE	39	27
CONTRACT NO. 85734			ILLINOIS FED. AID PROJECT	

INLETS, SPECIAL

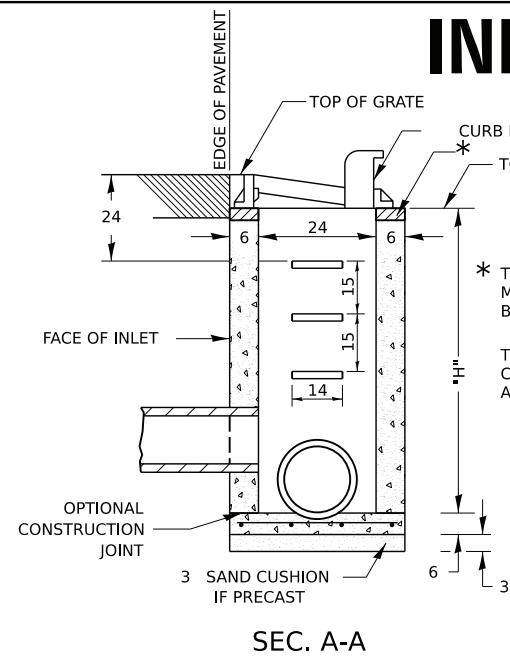

SEC. A-A

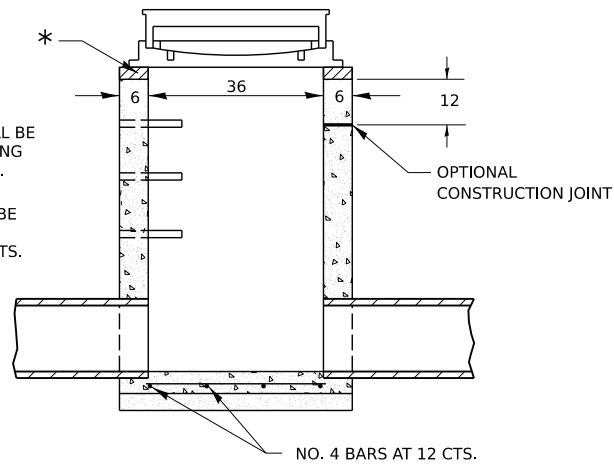

SEC. B-B

NOTES

- SEE STANDARD 602701 FOR DETAILS OF STEPS.
- EXCEPT AS NOTED HEREON INLET SPECIAL SHALL BE CONSTRUCTED IN ACCORDANCE WITH SECTION 602 OF THE STANDARD SPECIFICATIONS.
- THE SIDE WALLS MAY BE BUILT AS PRECAST SEGMENTED SECTIONS.
- ALL VOIDS AROUND PIPE ENTRANCE, BOTH INSIDE AND OUTSIDE, SHALL BE SEALED WITH MORTAR.
- WEIGHT OF CAST IRON FRAME & GRATE = 530 lbs. ± . STEPS SHALL BE OMITTED WHEN DEPTH OF "H" IS LESS THAN 5 ft.
- CLASS SI CONCRETE OR PRECAST CONCRETE SHALL BE USED THROUGHOUT. PRECAST CONCRETE SHALL BE IN ACCORDANCE WITH ARTICLES 504.01 THRU 504.05 OF THE STANDARD SPECIFICATIONS EXCEPT THAT CONCRETE STRENGTH SHALL BE 4,000 psi AFTER 28 DAYS.
- THE CONTRACT UNIT PRICE EACH FOR INLETS, SPECIAL SHALL INCLUDE THE COST OF CONSTRUCTING THE INLET BOX, FURNISHING AND INSTALLING THE FRAME AND GRATE, THE CAST IRON STEPS (IF USED), THE PRECAST FLOOR SLABS, SAND CUSHION (WHEN USED) AND REINFORCEMENT BARS.

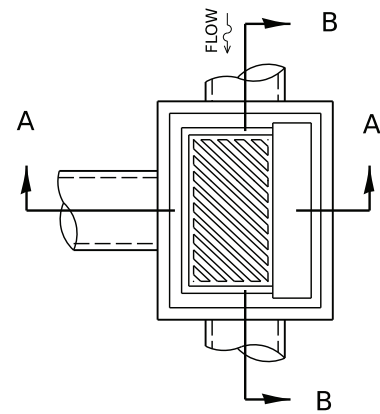

DETAIL OF FRAME & GRATE

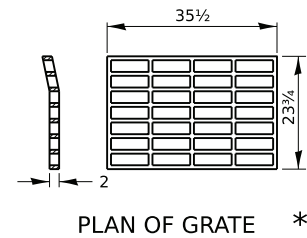
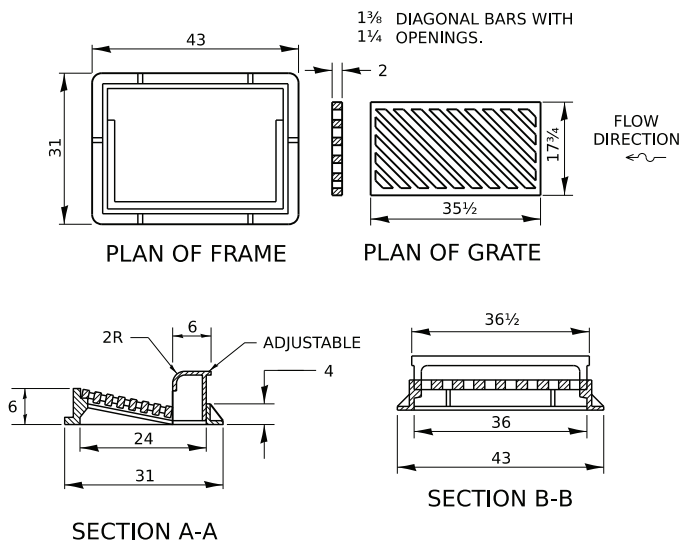

* THIS GRATE TO BE USED WITHOUT CURB BOX WHEN INLET IS IN DRIVEWAY.

ALL DIMENSIONS ARE IN INCHES UNLESS OTHERWISE NOTED.

INLETS, SPECIAL 10.2

STATE OF ILLINOIS
DEPARTMENT OF TRANSPORTATION

INLETS, SPECIAL
IDOT DISTRICT 2

SCALE: SHEET OF SHEETS STA. TO STA.

F.A.U. RTE.	SECTION	COUNTY	TOTAL SHEETS	SHEET NO.
5560	I7-00228-00-BR	WHITESIDE	39	28
CONTRACT NO.				
PROJECT 7164	ILLINOIS	FED. AID PROJECT		

MODEL: Default FILE NAME: R:\P\County\7164 Whiteside Co - Dixon Ave Bridge\CADD\CADD_Civil\ Erecting_Sect\28-7164-Inlet Details.dgn

REVISED - 1-05-16
REVISED - 6-27-14
REVISED - 10-13-11

CHASTAIN & ASSOCIATES LLC
CONSULTING ENGINEERS

USER NAME = jmadara	DESIGNED - ARF	REVISED -
PLOT SCALE = 0.0833' / in.	DRAWN - JDM	REVISED -
PLOT DATE = 2/16/2023	CHECKED - TWO	REVISED -
	DATE - 02/15/2023	REVISED -

WORK ZONE SIGN DETAILS

ILLINOIS STANDARD G20-I100

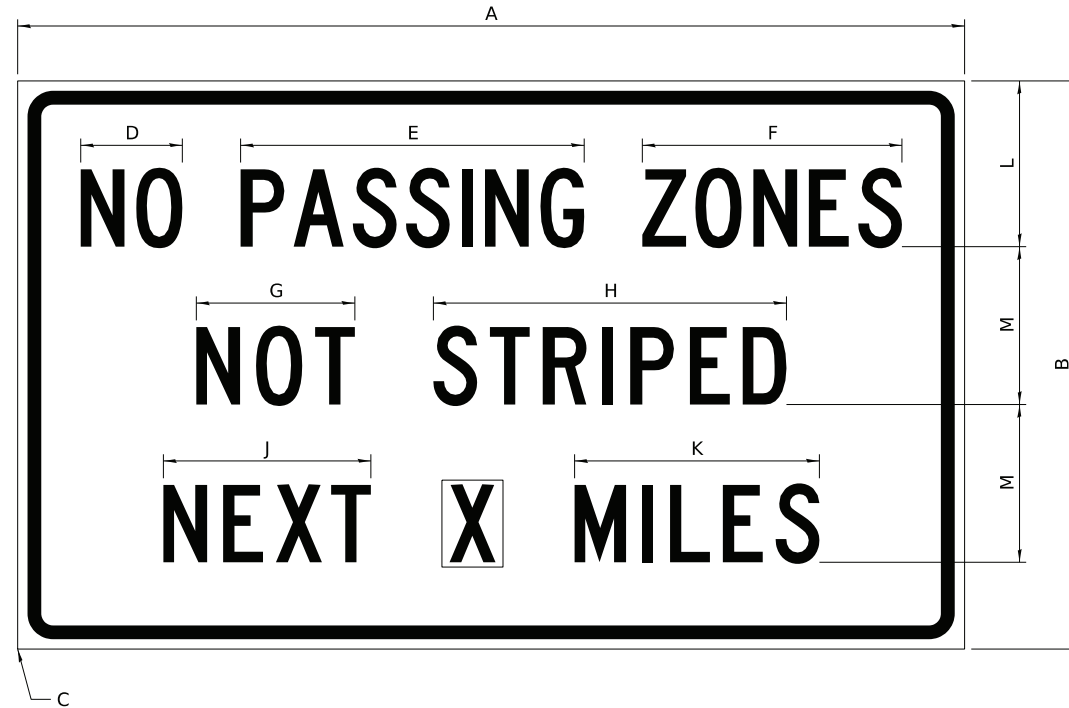

COLOR LEGEND AND BORDER BACKGROUND BLACK ORANGE NON-REFLECTORIZED REFLECTORIZED

SIGN SIZE	DIMENSIONS											
	A	B	C	D	E	F	G	H	J	K	L	M
60 x 36	60.00	36.00	2.25	6.4	21.80	16.40	10.00	22.40	13.20	15.50	10.50	10.00

SIGN SIZE	SERIES BY LINE			MARGIN	BORDER
	1	2	3		
60 x 36	5C	5C	5C	0.625	0.875

Sign not to scale

GENERAL NOTES

All work to furnish and install these signs shall be included in the cost of the specified traffic control standards and shall not be paid separately.

All Illinois Standard signs shall conform to the latest edition of the "Illinois Standard Highway Signs Book" in effect on the date of invitation for bids.

Signs shall meet the applicable portions of Sections 701 and 720 of the Standard Specifications.

All dimensions are in inches unless otherwise noted.

ILLINOIS STANDARD W8-I107

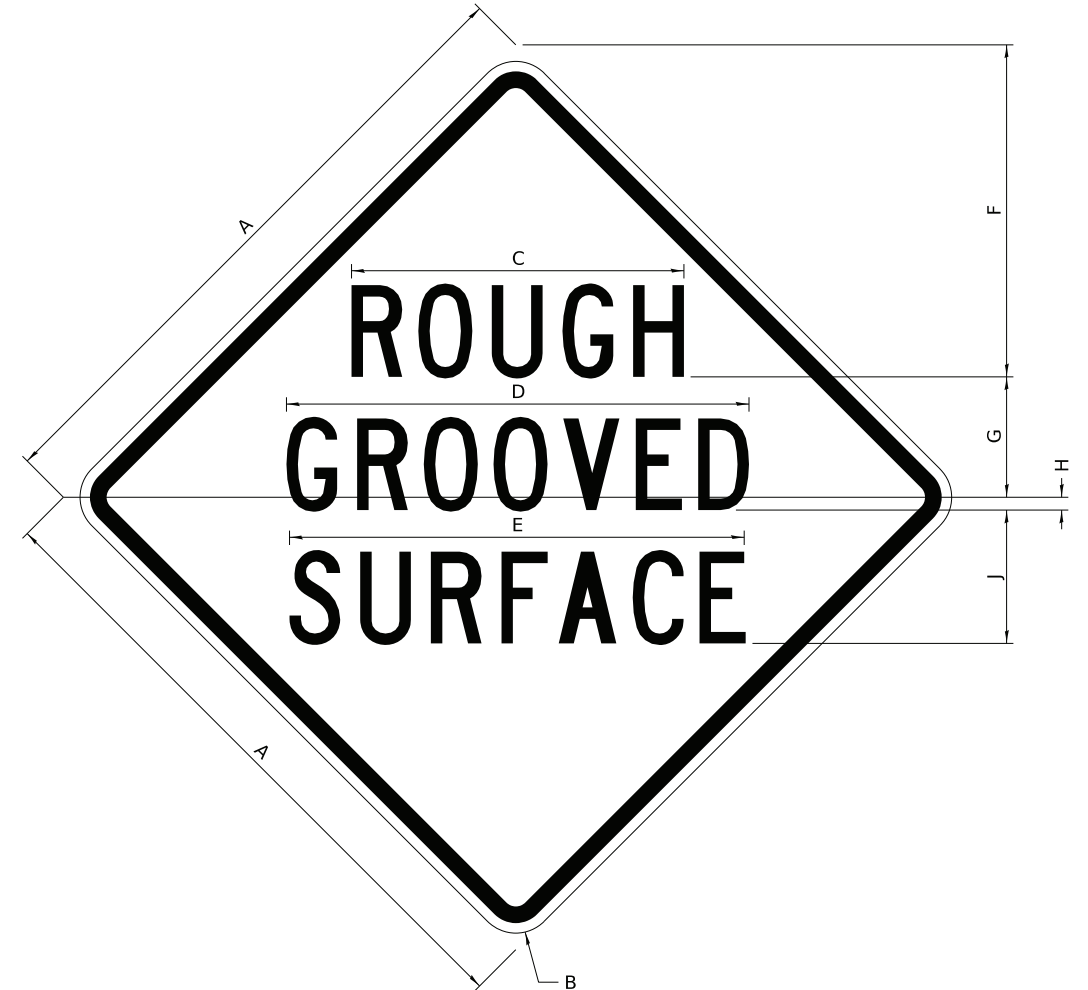

COLOR LEGEND AND BORDER BACKGROUND BLACK ORANGE NON-REFLECTORIZED REFLECTORIZED

SIGN SIZE	DIMENSIONS								
	A	B	C	D	E	F	G	H	J
48 x 48	48.00	3.00	25.00	34.80	34.20	24.94	9.00	1.00	10.00

SIGN SIZE	SERIES BY LINE			MARGIN	BORDER
	1	2	3		
48 x 48	7C	7C	7C	1.250	0.750

Sign not to scale

MODEL: Default FILE NAME: R:\P1_County\7164 Whiteside Co - Dixon Ave Bridge\CADD\CADD_Civil_Erecting_Sch20-7164-Work Zone Details.dgn



USER NAME = jmadara	DESIGNED - ARF	REVISED - 3-02-16
PLOT SCALE = 0.0833' / in.	DRAWN - JDM	REVISED -
PLOT DATE = 2/15/2023	CHECKED - TWO	REVISED -
	DATE - 02/15/2023	REVISED -

**STATE OF ILLINOIS
DEPARTMENT OF TRANSPORTATION**

**WORK ZONE DETAILS
IDOT DISTRICT 2**

SCALE: SHEET OF SHEETS STA. TO STA.

F.A.U. RTE.	SECTION	COUNTY	TOTAL SHEETS	SHEET NO.
5560	I7-00228-00-BR	WHITESIDE	39	29
PROJECT 7164 ILLINOIS FED. AID PROJECT			CONTRACT NO.	

WORK ZONE SIGN DETAILS

ILLINOIS STANDARD W12-I102

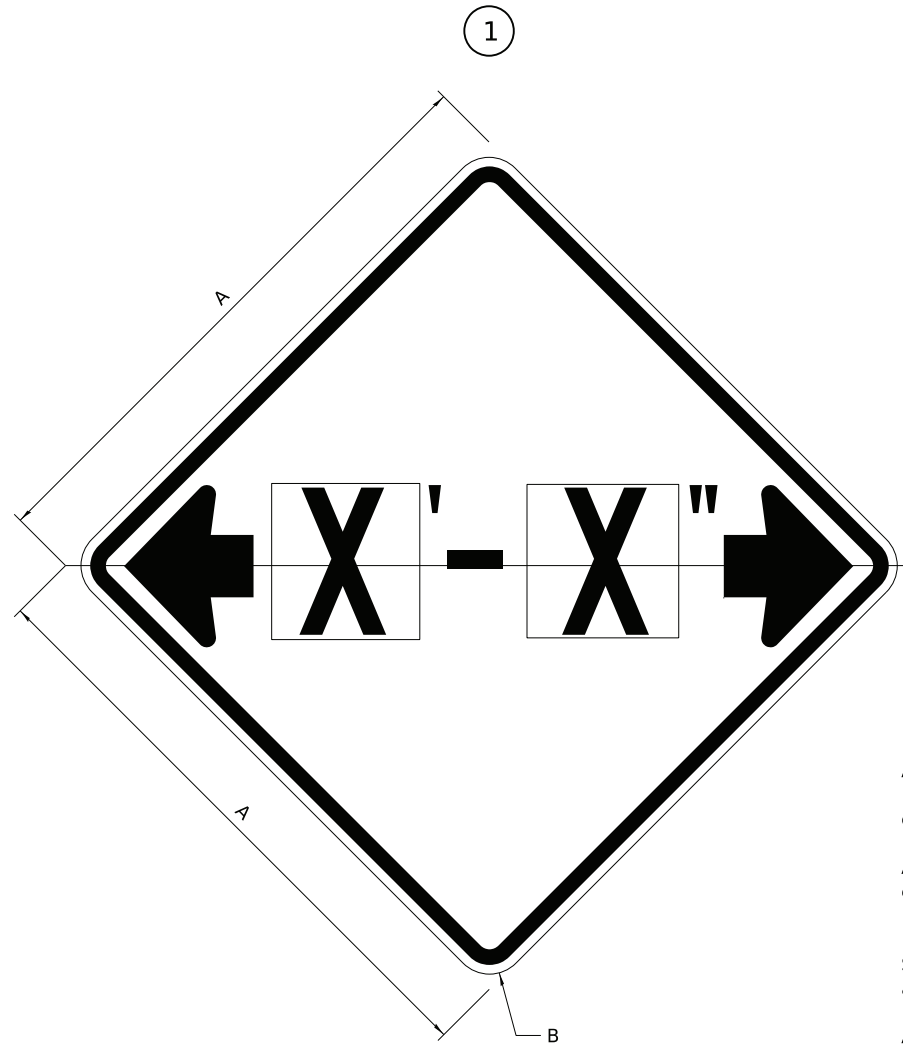

ILLINOIS STANDARD W12-I103

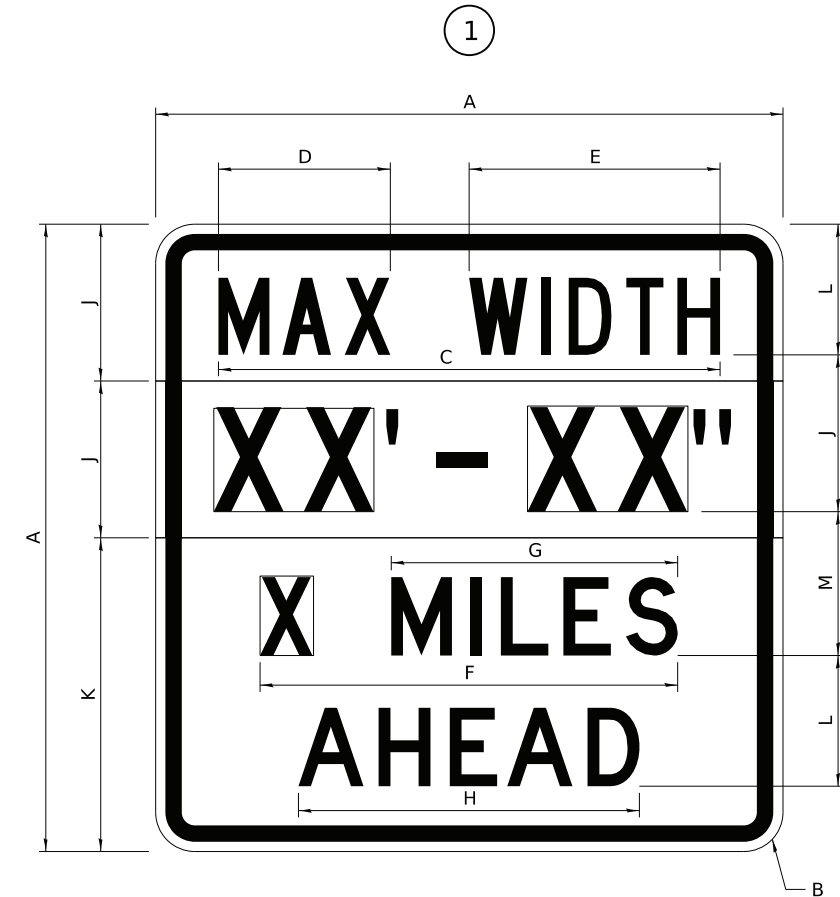

GENERAL NOTES

All work to furnish and install these signs shall be included in the cost of the specified traffic control standards and shall not be paid separately.

All Illinois Standard signs shall conform to the latest edition of the "Illinois Standard Highway Signs Book" in effect on the date of invitation for bids.

Signs shall meet the applicable portions of Sections 701 and 720 of the Standard Specifications.

All dimensions are in inches unless otherwise noted.

COLOR LEGEND AND BORDER BACKGROUND BLACK FL ORANGE NON-REFLECTORIZED REFLECTORIZED

SIGN SIZE	DIMENSIONS	
	A	B
48 x 48	48.00	3.00

① Illinois Standard signs W12-I102 and W12-I103 shall be used as described in the special provisions.

SIGN SIZE	SERIES BY LINE	MARGIN	BORDER
	1		
48 x 48	12C	0.750	1.250

Sign not to scale

COLOR LEGEND AND BORDER BACKGROUND BLACK WHITE FL ORANGE NON-REFLECTORIZED REFLECTORIZED REFLECTORIZED

SIGN SIZE	DIMENSIONS											
	A	B	C	D	E	F	G	H	J	K	L	M
48 x 48	48.00	3.00	38.40	13.20	19.20	32.00	22.00	26.20	12.00	24.00	10.00	11.00

SIGN SIZE	SERIES BY LINE				MARGIN	BORDER
	1	2	3	4		
48 x 48	6C	8D	6D	6D	0.750	1.250

Sign not to scale

XX'-XX" WIDTH AND X MILES ARE VARIABLE TOP AND BOTTOM OF BACKGROUND WHITE

MODEL: Default; FILE NAME: R:\P\ County\7164 Whiteside Co - Dixon Ave Bridge\CADD\CADD_Civil_Erecting Set\29-7164-Work Zone Details.dgn



USER NAME = jmadara	DESIGNED - ARF	REVISED - 3-02-16
PLOT SCALE = 0.0833' / in.	DRAWN - JDM	REVISED -
PLOT DATE = 2/15/2023	CHECKED - TWO	REVISED -
	DATE - 02/15/2023	REVISED -

STATE OF ILLINOIS
DEPARTMENT OF TRANSPORTATION

WORK ZONE DETAILS
IDOT DISTRICT 2

SCALE: SHEET OF SHEETS STA. TO STA.

F.A.U. RTE.	SECTION	COUNTY	TOTAL SHEETS	SHEET NO.
5560	17-00228-00-BR	WHITESIDE	39	30
PROJECT 7164 ILLINOIS FED. AID PROJECT			CONTRACT NO.	

WORK ZONE SIGN DETAILS

ROAD CLOSED TO OVERSIZED LOADS

STOP LINE SIGN FOR TEMPORARY SIGNALS

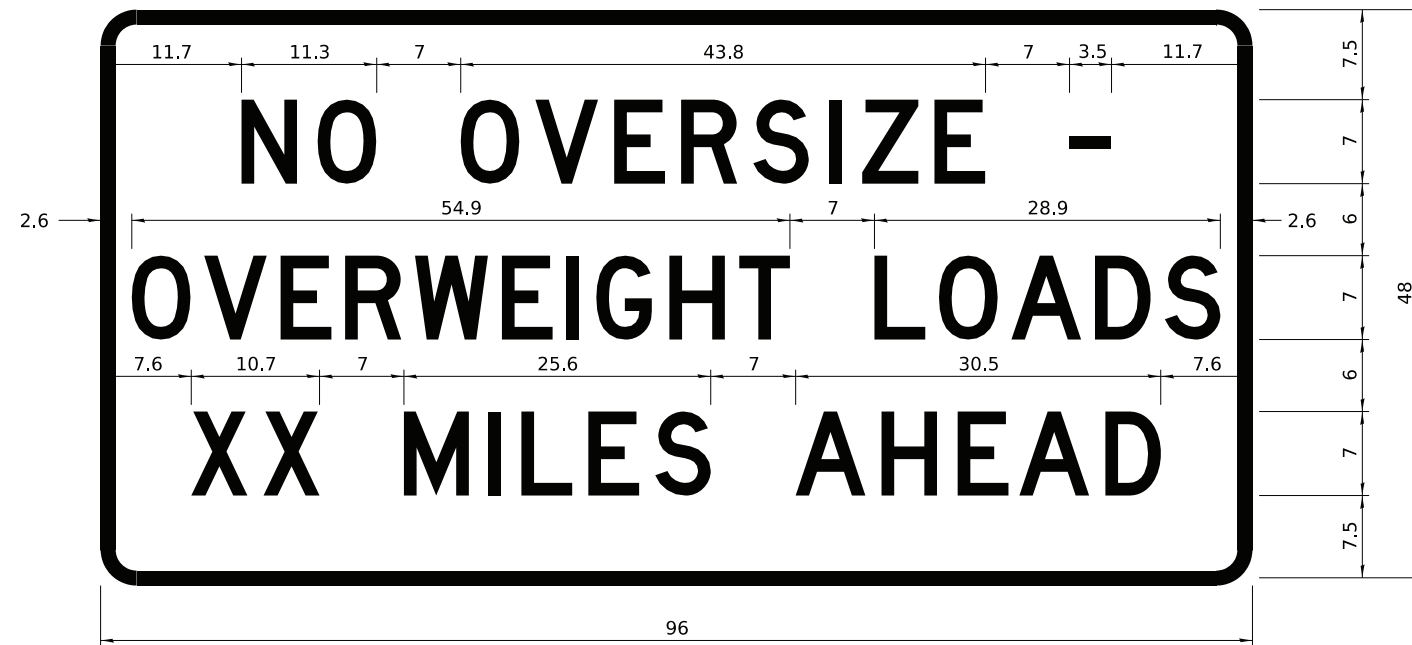

COLOR	LEGEND AND BORDER BACKGROUND	BLACK ORANGE	NON-REFLECTORIZED REFLECTORIZED
-------	------------------------------	--------------	---------------------------------

COLOR	LEGEND AND BORDER BACKGROUND	BLACK WHITE	NON-REFLECTORIZED REFLECTORIZED
-------	------------------------------	-------------	---------------------------------

Permit Loads - Loads Over 13 Feet; 3.0" Radius, 1.3" Border;
 [NO OVERSIZE -] D; [OVERWEIGHT LOADS] D 85% spacing; [XX MILES AHEAD] D;
 Table of letter and object lefts.

SIGN SIZE	SERIES BY LINE		
	1	2	3
24 x 24	4C	4C	4C

N	O	O	V	E	R	S	I	Z	E	-
11.7	18.1	30.0	36.2	42.8	48.4	54.4	60.7	63.5	69.5	80.8

O	V	E	R	W	E	I	G	H	T	L	O	A	D	S
2.6	8.6	15.0	20.4	26.2	33.4	38.8	41.3	47.4	53.2	64.5	69.9	75.9	82.9	88.7

X	X	M	I	L	E	S	A	H	E	A	D
7.6	13.6	25.3	32.3	35.1	40.6	46.2	57.9	65.1	71.4	76.6	83.7

Sign not to scale

Sign not to scale

GENERAL NOTES

All work to furnish and install these signs shall be included in the cost of the specified traffic control standards and shall not be paid separately.

All Illinois Standard signs shall conform to the latest edition of the "Illinois Standard Highway Signs Book" in effect on the date of invitation for bids.

Signs shall meet the applicable portions of Sections 701 and 720 of the Standard Specifications.

All dimensions are in inches unless otherwise noted.

MODEL: Default; FILE NAME: R:\P\ County\7164 Whiteside Co - Dixon Ave Bridge\CADD\CADD_Civil\ Erecting Set\29-7164-Work Zone Details.dgn



USER NAME = jmadara	DESIGNED - ARF	REVISED - 3-02-16
PLOT SCALE = 0.0833' / in.	DRAWN - JDM	REVISED -
PLOT DATE = 2/15/2023	CHECKED - TWO	REVISED -
	DATE - 02/15/2023	REVISED -

STATE OF ILLINOIS
DEPARTMENT OF TRANSPORTATION

WORK ZONE DETAILS			
IDOT DISTRICT 2			
SCALE:	SHEET	OF SHEETS	STA. TO STA.

F.A.U. RTE.	SECTION	COUNTY	TOTAL SHEETS	SHEET NO.
5560	17-00228-00-BR	WHITESIDE	39	31
PROJECT 7164 ILLINOIS FED. AID PROJECT				

**ENTRANCE SIGN FOR USE
WITH TEMPORARY SIGNALS**

WORK ZONE SIGN DETAILS

2

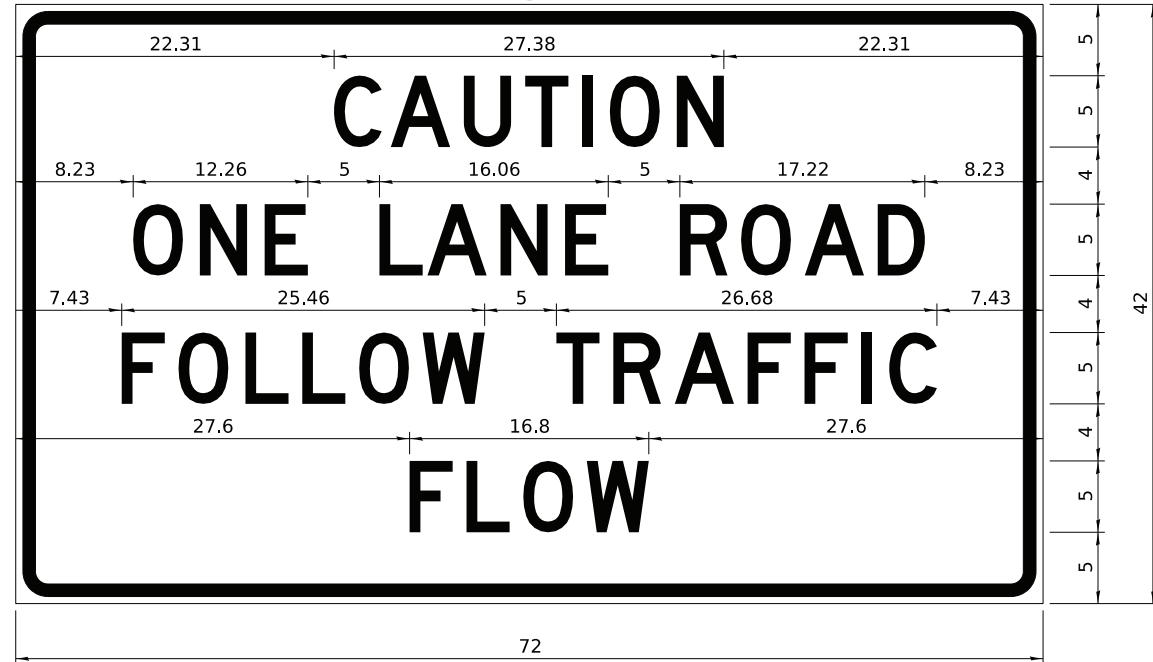

COLOR LEGEND AND BORDER BACKGROUND BLACK ORANGE NON-REFLECTORIZED REFLECTORIZED

2.25" Radius, 0.88" Border, 0.50" Indent;
[CAUTION] D; [ONE LANE ROAD] D;
[FOLLOW TRAFFIC] D; [FLOW] D

2 This sign shall be installed at entrances located between the temporary signals as shown in the staging plans.

Table Of Widths And Spaces

22.31	C	A	U	T	I	O	N	22.31					
3.36	0.62	4.18	0.94	3.36	0.94	3.04	0.94	0.78	1.17	3.52	1.17	3.36	22.31

8.23	O	N	E	
3.51	1.17	3.36	1.18	3.04

5.00	L	A	N	E		
3.05	0.31	4.18	0.94	3.36	1.17	3.05

5.00	R	O	A	D			
3.36	0.93	3.52	0.94	4.18	0.93	3.36	8.23

7.43	F	O	L	L	O	W				
3.04	0.94	3.52	1.17	3.04	0.94	3.05	0.94	3.51	0.94	4.37

5.00	T	R	A	F	F	I	C						
3.05	0.94	3.36	0.94	4.18	0.93	3.05	0.94	3.04	0.94	0.78	1.18	3.35	7.43

27.60	F	L	O	W			
3.05	0.94	3.04	0.94	3.52	0.93	4.38	27.60

Sign not to scale

GENERAL NOTES

All work to furnish and install these signs shall be included in the cost of the specified traffic control standards and shall not be paid separately.

All Illinois Standard signs shall conform to the latest edition of the "Illinois Standard Highway Signs Book" in effect on the date of invitation for bids.

Signs shall meet the applicable portions of Sections 701 and 720 of the Standard Specifications.

All dimensions are in inches unless otherwise noted.

STAY IN YOUR LANE

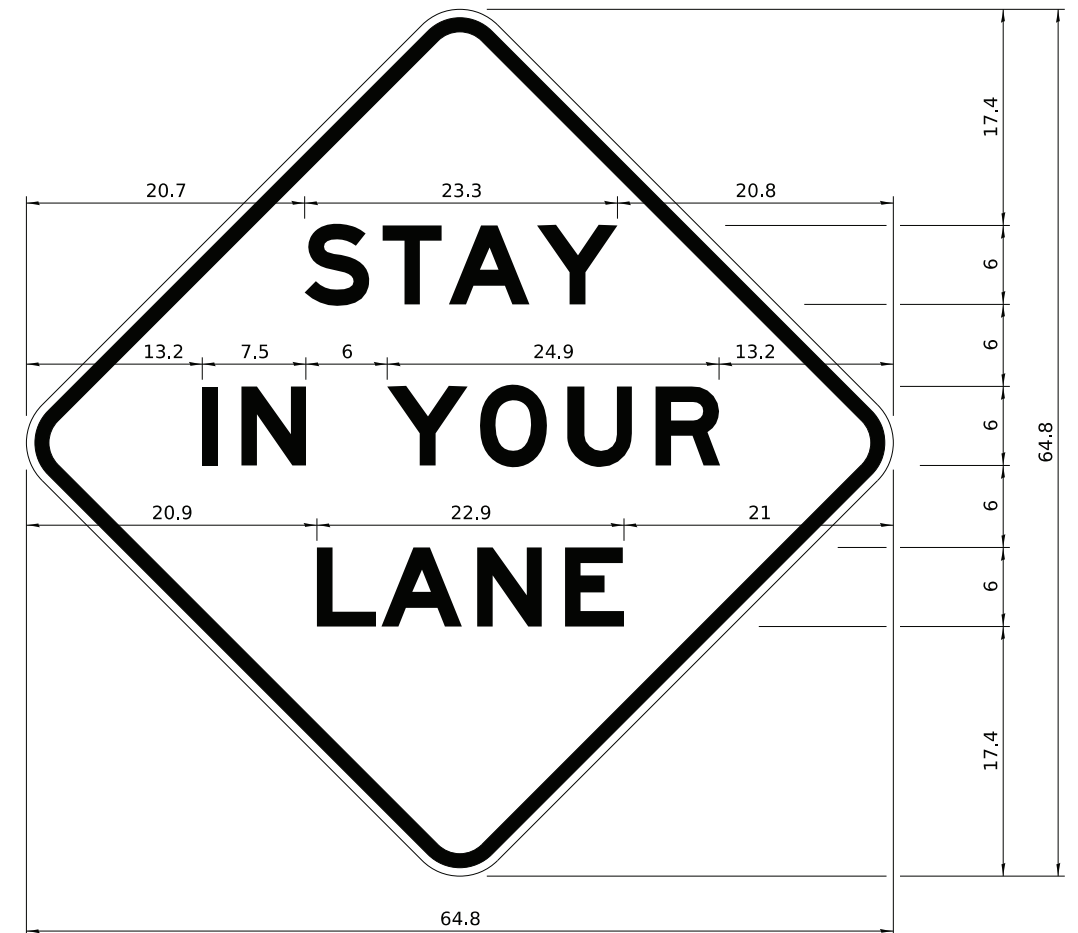

COLOR LEGEND AND BORDER BACKGROUND BLACK ORANGE NON-REFLECTORIZED REFLECTORIZED

48.0" across sides 3.8" Radius, 1.0" Border, 0.6" Indent;
"STAY" E Mod; "IN YOUR" E Mod; "LANE" E Mod;

Table of Letter and Object Lefts

S	T	A	Y
20.7	26.8	31.6	38.0

I	N	Y	O	U	R
13.2	15.9	26.7	33.9	40.5	46.8

L	A	N	E
20.9	25.8	33.1	39.4

Sign not to scale

MODEL: Default; FILE NAME: R:\P1_County\7164 Whiteside Co - Dixon Ave Bridge\CADD\CADD_Civil\Errecting_Signs\25-7164-Work_Zone_Details.dgn



USER NAME = jmadara	DESIGNED - ARF	REVISED - 3-02-16
PLOT SCALE = 0.0833' / in.	DRAWN - JDM	REVISED -
PLOT DATE = 2/15/2023	CHECKED - TWO	REVISED -
	DATE - 02/15/2023	REVISED -

**STATE OF ILLINOIS
DEPARTMENT OF TRANSPORTATION**

**WORK ZONE DETAILS
IDOT DISTRICT 2**

SCALE: SHEET OF SHEETS STA. TO STA.

F.A.U. RTE.	SECTION	COUNTY	TOTAL SHEETS	SHEET NO.
5560	I7-00228-00-BR	WHITESIDE	39	32
CONTRACT NO.				
PROJECT 7164	ILLINOIS	FED. AID PROJECT		

TRAFFIC CONTROL FOR THREE LANE SECTION CASE 1

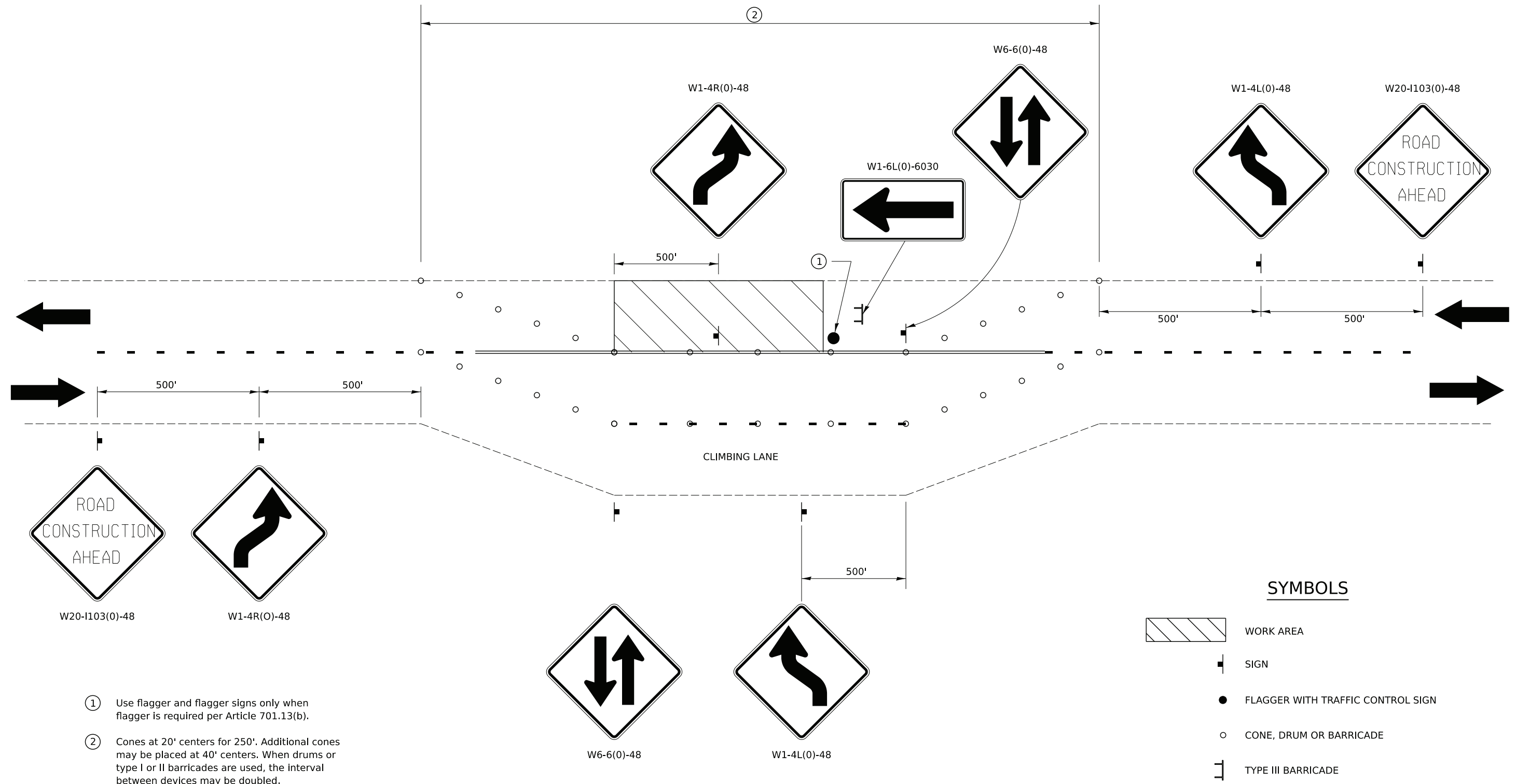

- ① Use flagger and flagger signs only when flagger is required per Article 701.13(b).
- ② Cones at 20' centers for 250'. Additional cones may be placed at 40' centers. When drums or type I or II barricades are used, the interval between devices may be doubled.

THIS TRAFFIC CONTROL DETAIL SHALL BE INCLUDED IN THE COST OF SPECIFIED TRAFFIC CONTROL STANDARDS OR ITEMS.

MODEL Default
FILE NAME: R:\Illinois\County\7164\Whiteside Co - Dixon Ave Bridge\CADD\CADD_Civil_Erecting Set\34-7164-Work Zone Details.dgn



USER NAME = jmadara	DESIGNED - ARF	REVISED - 1-05-16
	DRAWN - JDM	REVISED - 8-27-13
PLOT SCALE = 0.0834' / in.	CHECKED - TWO	REVISED - 7-30-13
PLOT DATE = 2/15/2023	DATE - 02/15/2023	REVISED -

**STATE OF ILLINOIS
DEPARTMENT OF TRANSPORTATION**

TRAFFIC CONTROL FOR THREE LANE SECTION IDOT DISTRICT 2			
SCALE:	SHEET	OF SHEETS	STA. TO STA.

F.A.U. RTE.	SECTION	COUNTY	TOTAL SHEETS	SHEET NO.
5560	I7-00228-00-BR	WHITESIDE	39	33
CONTRACT NO.				
PROJECT 7164	ILLINOIS	FED. AID PROJECT		

TRAFFIC CONTROL FOR THREE LANE SECTION CASE 4

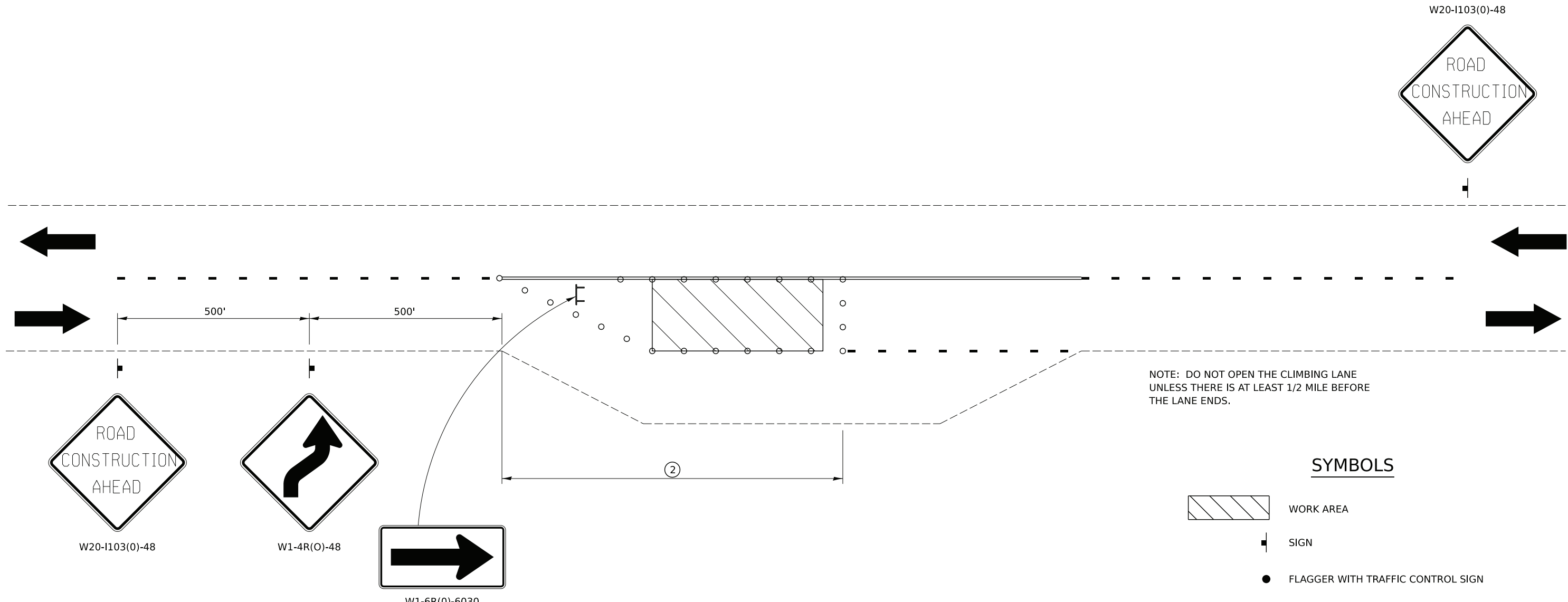

NOTE: DO NOT OPEN THE CLIMBING LANE UNLESS THERE IS AT LEAST 1/2 MILE BEFORE THE LANE ENDS.

SYMBOLS

- WORK AREA
- SIGN
- FLAGGER WITH TRAFFIC CONTROL SIGN
- CONE, DRUM OR BARRICADE
- TYPE III BARRICADE

② Cones at 20' centers for 250'. Additional cones may be placed at 40' centers. When drums or type I or II barricades are used, the interval between devices may be doubled.

THIS TRAFFIC CONTROL DETAIL SHALL BE INCLUDED IN THE COST OF SPECIFIED TRAFFIC CONTROL STANDARDS OR ITEMS.

CASE 4 APPLIES WHEN NO WORKERS ARE PRESENT. WHEN WORKERS ARE PRESENT, TWO LANES SHALL BE CLOSED AND TRAFFIC CONTROL SHALL BE ACCORDING TO CASE 3.

MODEL Default: R:\11\11\County7164\Whiteside Co - Dixon Ave Bridge\CADD\CADD_Civil_Erecting Set\34-7164-Work Zone Details.dgn

CHASTAIN & ASSOCIATES LLC <small>CONSULTING ENGINEERS</small>	USER NAME = jmadara	DESIGNED - ARF	REVISED - 1-05-16
	PLOT SCALE = 0.0834' / in.	DRAWN - JDM	REVISED - 8-27-13
	PLOT DATE = 2/15/2023	CHECKED - TWO	REVISED - 7-30-13
		DATE - 02/15/2023	REVISED -

**STATE OF ILLINOIS
DEPARTMENT OF TRANSPORTATION**

**TRAFFIC CONTROL FOR THREE LANE SECTION
IDOT DISTRICT 2**

F.A.U. RTE.	SECTION	COUNTY	TOTAL SHEETS	SHEET NO.
5560	I7-00228-00-BR	WHITESIDE	39	36
CONTRACT NO.				
PROJECT 7164	ILLINOIS	FED. AID PROJECT		

DATE	
BY	
FINAL SURVEY	SURVEYED
NOTE BOOK	PLOTTED
NO.	TEMPLATE
	AREAS
	CHECKED

DATE	
BY	
ORIGINAL SURVEY	SURVEYED
NOTE BOOK	PLOTTED
NO.	TEMPLATE
	AREAS
	CHECKED

MODEL: EXCL - 108+80.48 (Sheet)
 FILE NAME: R:\proj\County\164\Whiteside Co - Dixon Ave Bridge\CADD\CADD_Civil_Erecting_Sec13-39-164-Sec.dgn

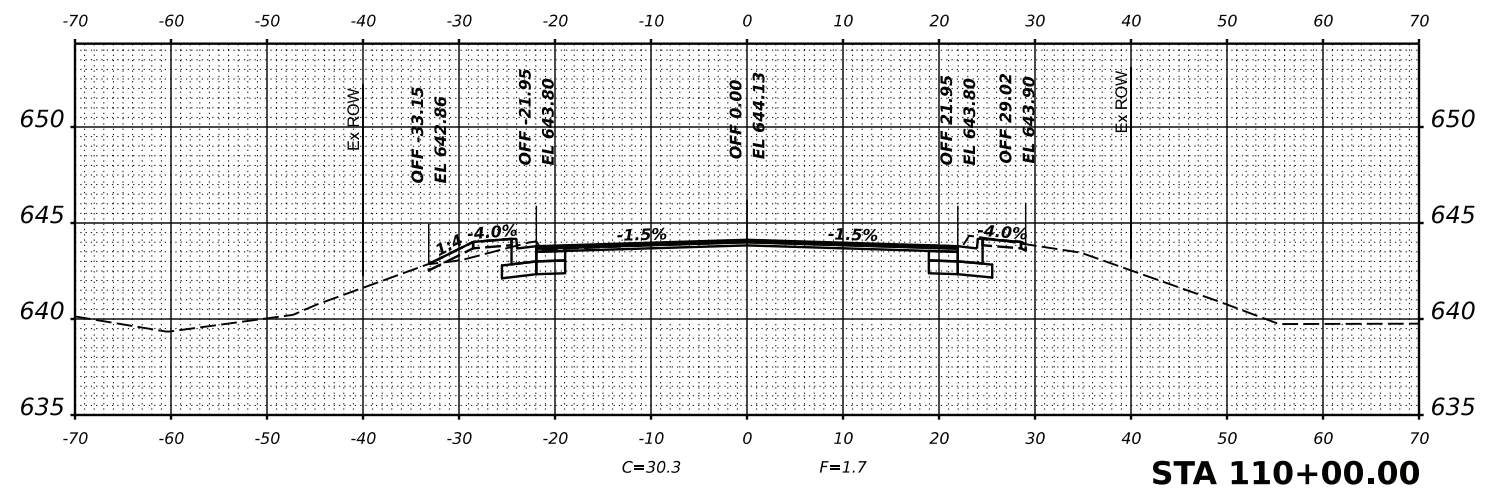
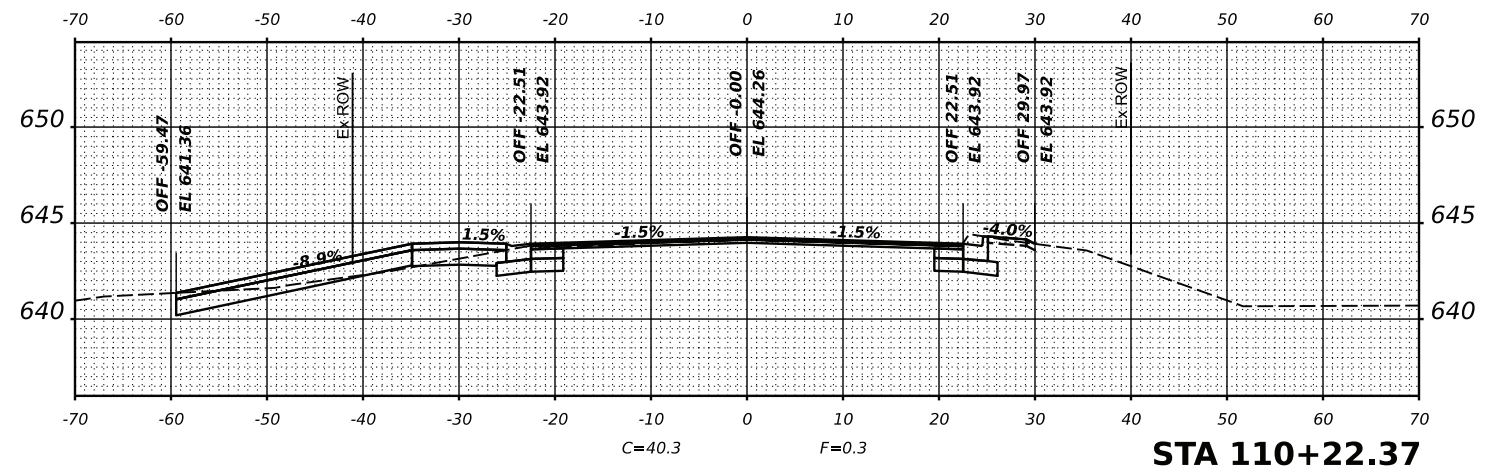
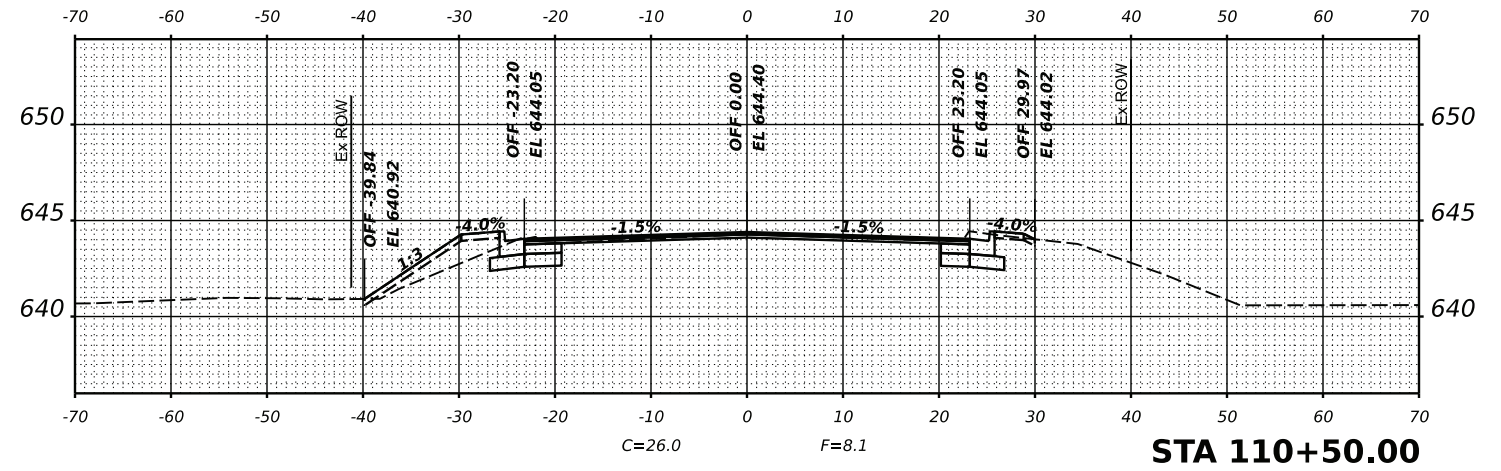
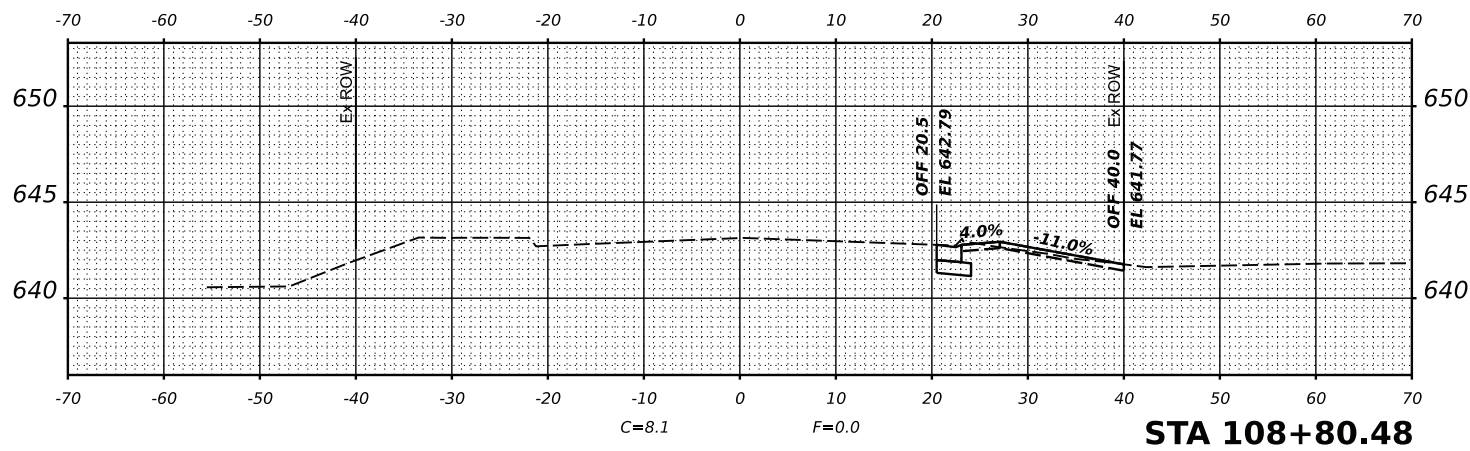
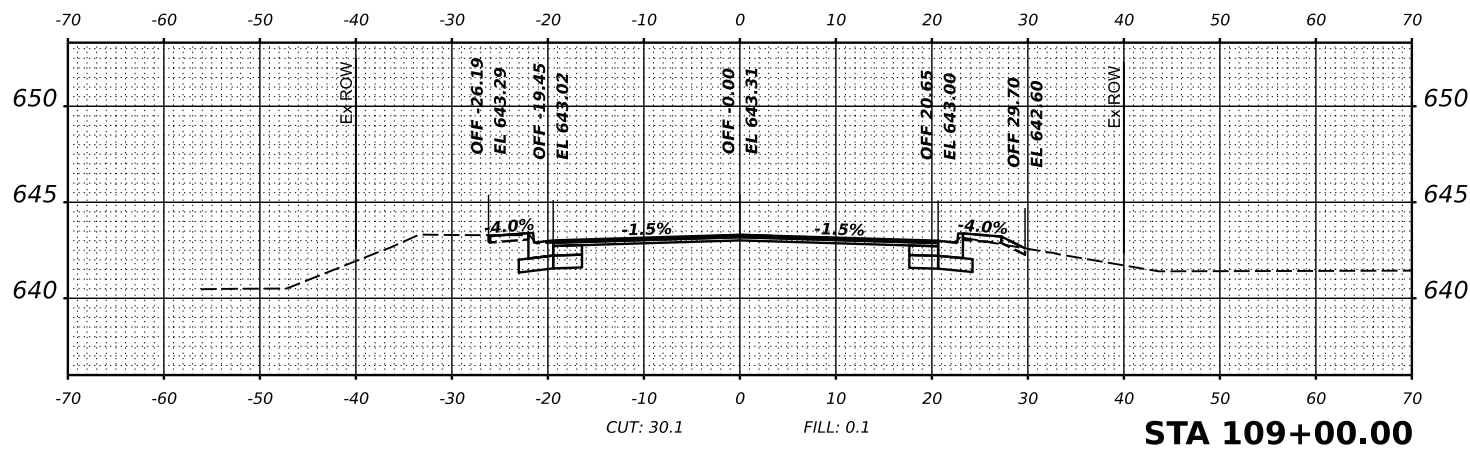
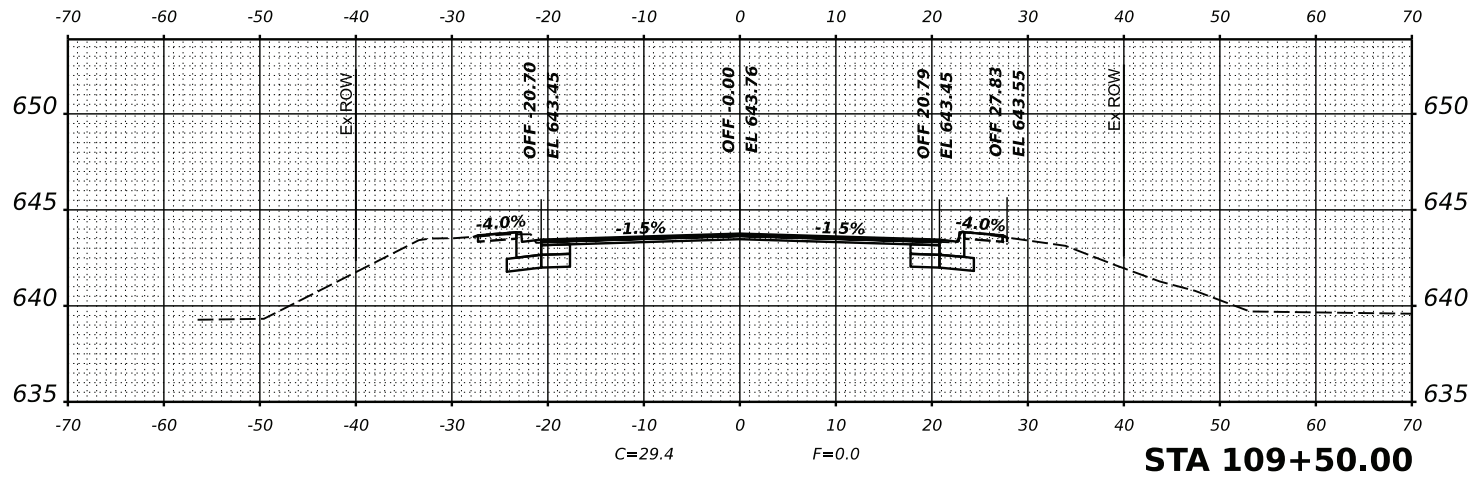

USER NAME	= jmadara
DESIGNED	- ARF
DRAWN	- JDM
PLLOT SCALE	= 0.08333317' / in.
PLLOT DATE	= 2/15/2023

REVISD	-
REVISD	-
REVISD	-
REVISD	-

STATE OF ILLINOIS
 DEPARTMENT OF TRANSPORTATION

SCALE: SCALE	SHEET	OF	SHEETS	STA.
--------------	-------	----	--------	------

CROSS SECTIONS
 CH 3 (DIXON AVENUE) OVER HOWLAND CREEK

F.A.U. RTE.	SECTION	COUNTY	TOTAL SHEETS	SHEET NO.
5560	17-00228-00-BR	WHITESIDE	39	37
PROJECT 7164		ILLINOIS	FED. AID PROJECT	

DATE	
BY	
FINAL SURVEY	SURVEYED
NOTE BOOK	PLOTTED
NO.	TEMPLATE
	AREAS
	CHECKED

DATE	
BY	
ORIGINAL SURVEY	SURVEYED
NOTE BOOK	PLOTTED
NO.	TEMPLATE
	AREAS
	CHECKED

MODEL EXCL - 111+00.00 (Sheet)
 FILE NAME: R:\01_Country\1164_Whiteside Co - Dixon Ave Bridge\CADD\CADD_Civil_Erecting_Set\37-39-7164-3Sec.dgn

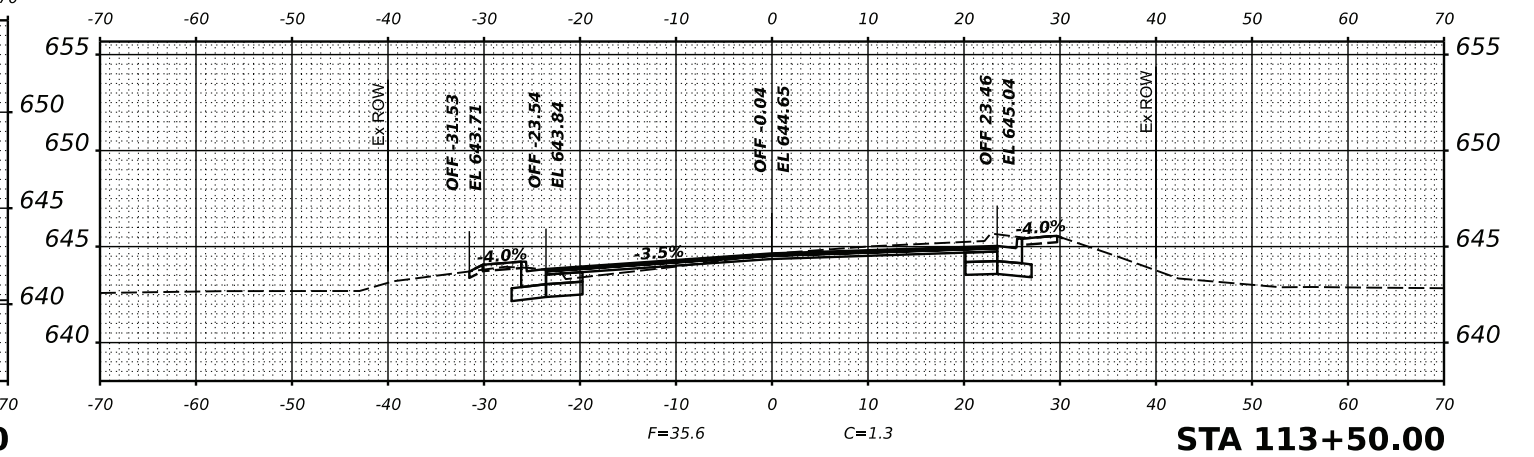
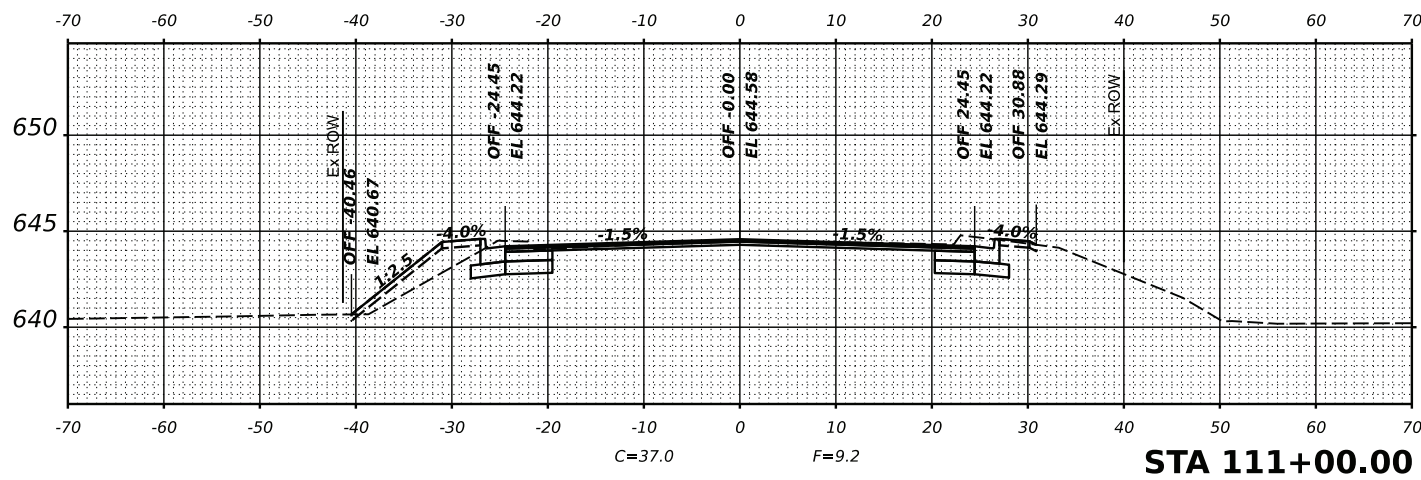
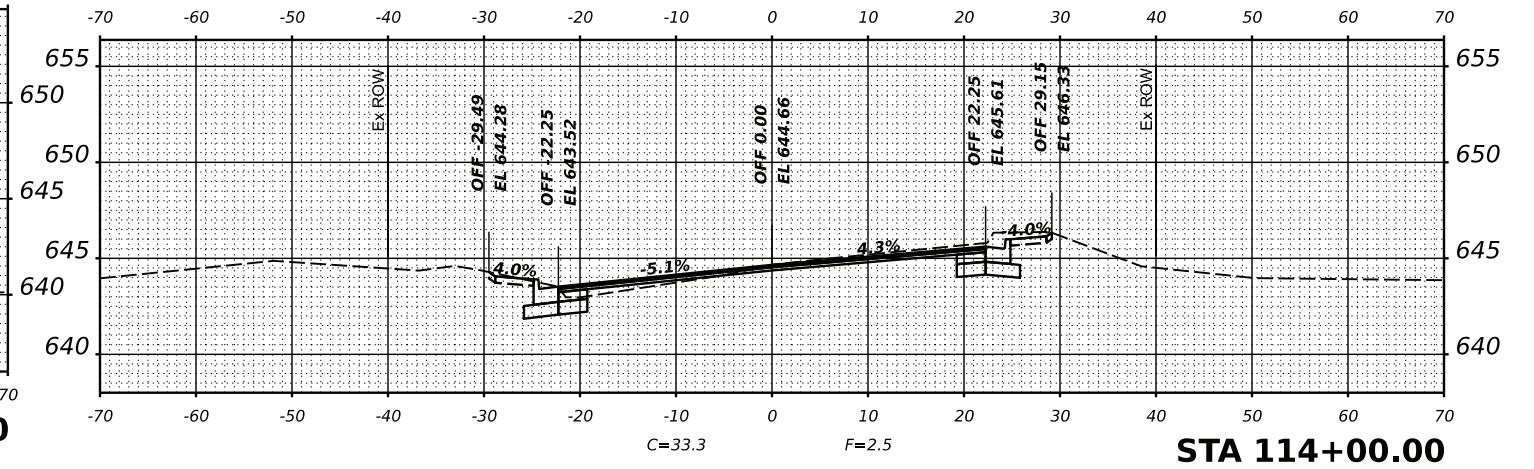
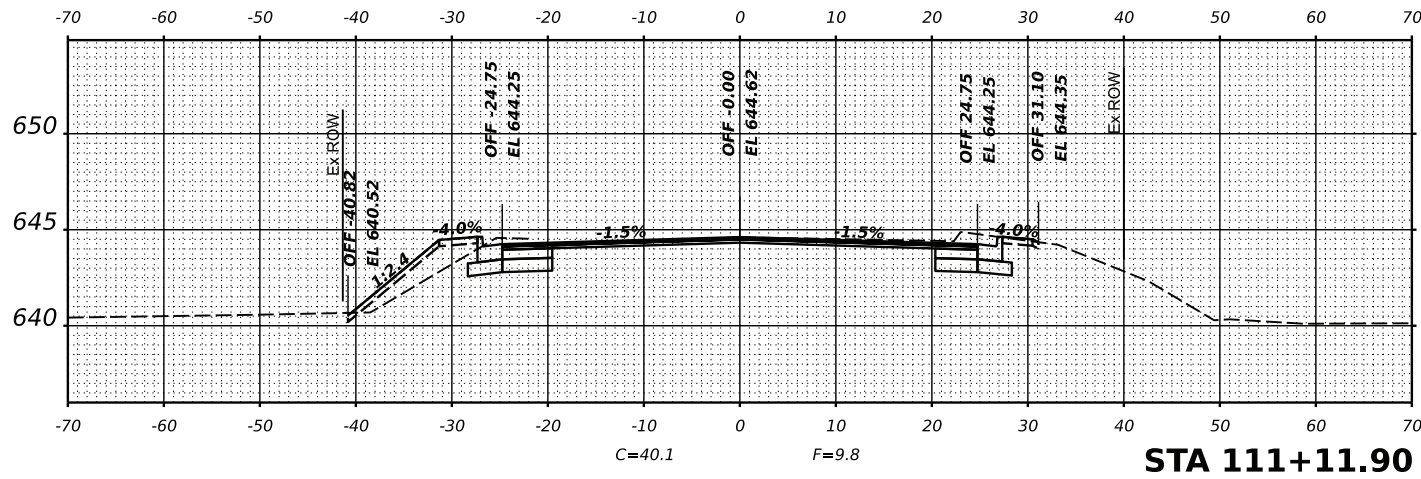
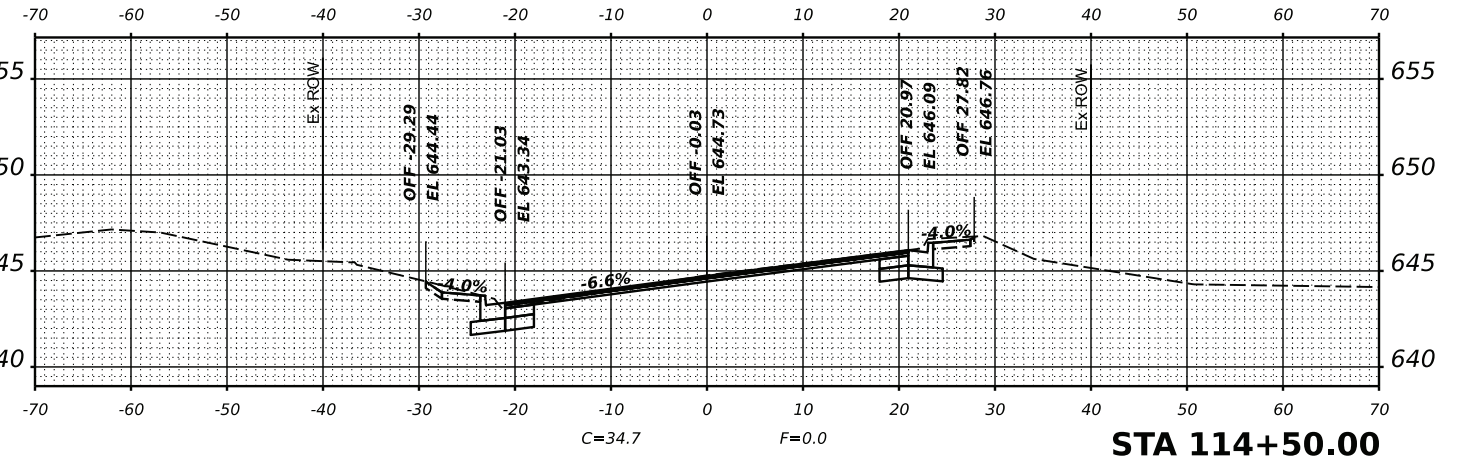
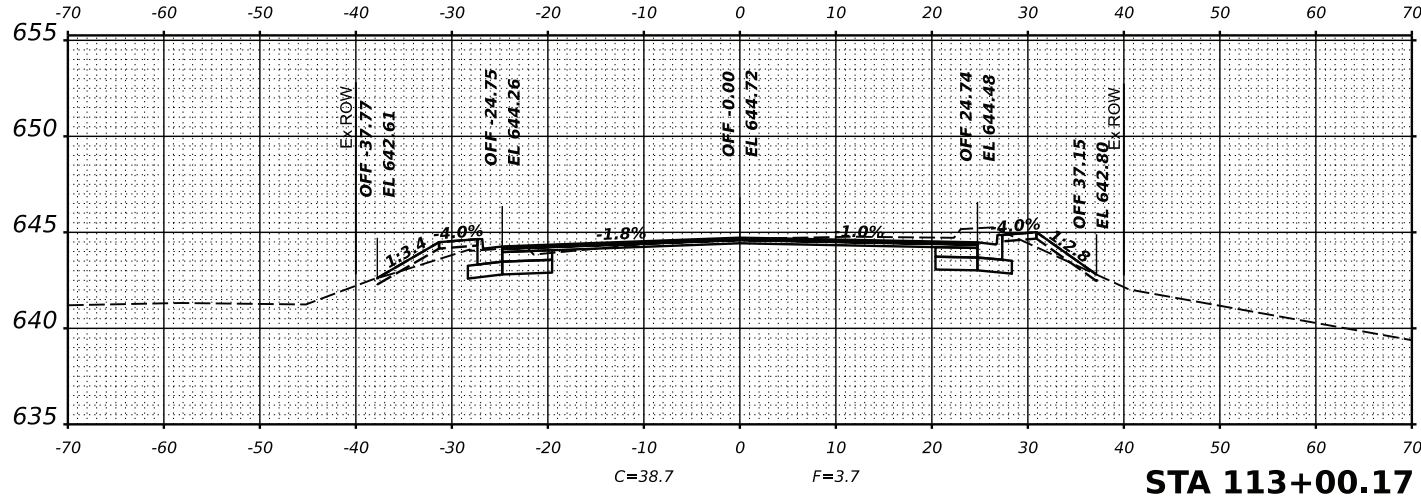

USER NAME	= jmadara
DESIGNED	- ARF
DRAWN	- JDM
PLLOT SCALE	= 0.08333317' / in.
PLLOT DATE	= 2/15/2023

REVISIED	-
REVISIED	-
REVISIED	-
REVISIED	-

STATE OF ILLINOIS
 DEPARTMENT OF TRANSPORTATION

SCALE:	SHEET	OF	SHEETS	STA.
--------	-------	----	--------	------

CROSS SECTIONS
 CH 3 (DIXON AVENUE) OVER HOWLAND CREEK

F.A.U. RTE.	SECTION	COUNTY	TOTAL SHEETS	SHEET NO.
5560	17-00228-00-BR	WHITESIDE	39	38
PROJECT 7164		ILLINOIS FED. AID PROJECT		

FINAL SURVEY NO.	SURVEYED PLOTTED AREAS CHECKED	BY	DATE

ORIGINAL SURVEY NO.	SURVEYED PLOTTED AREAS CHECKED	BY	DATE

MODEL: EXCL - 115+00.00 (Sheet)
 FILE NAME: R:\17-00228\17164 Whiteside Co - Dixon Ave Bridge\CADD\CADD_Civil_Erecting Set\37-39-7164-XSec.dgn

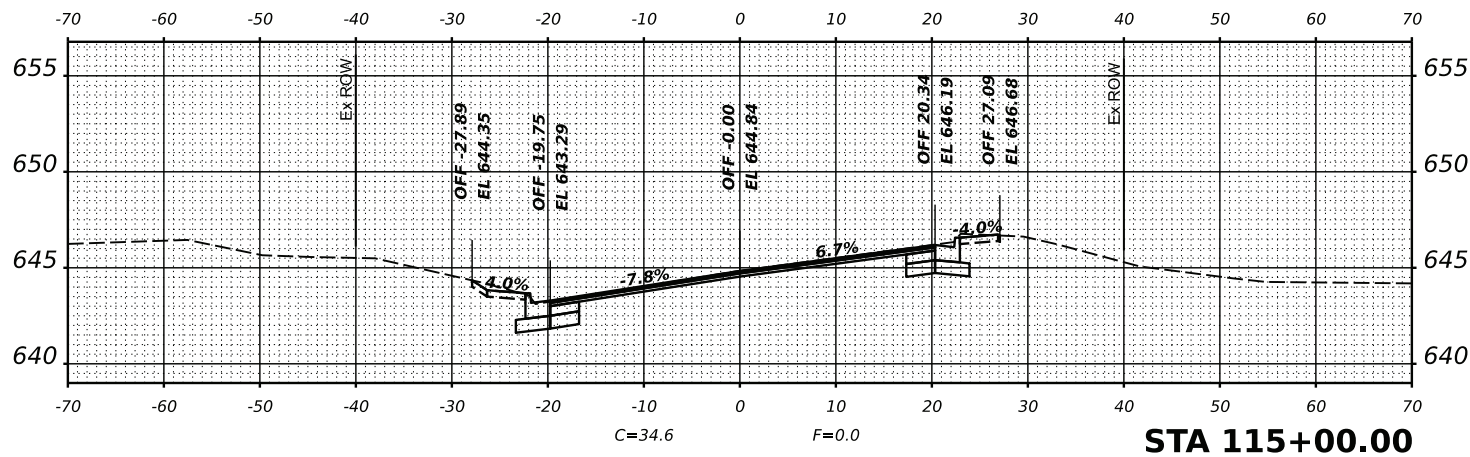
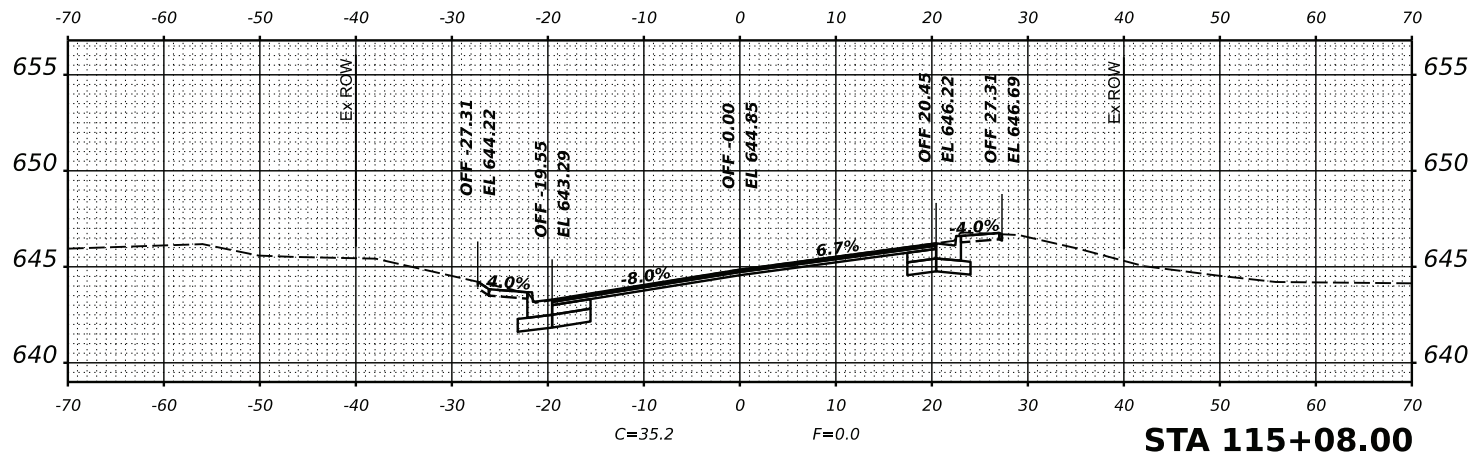

USER NAME = jmadara	DESIGNED - ARF	REVISED -
PLOT SCALE = 0.08333317' / in.	DRAWN - JDM	REVISED -
PLOT DATE = 2/15/2023	CHECKED - ARF	REVISED -
	DATE - 02/15/2023	REVISED -

STATE OF ILLINOIS
 DEPARTMENT OF TRANSPORTATION

CROSS SECTIONS
 CH 3 (DIXON AVENUE) OVER HOWLAND CREEK

SCALE: SHEET OF SHEETS STA.

F.A.U. RTE.	SECTION	COUNTY	TOTAL SHEETS	SHEET NO.
5560	17-00228-00-BR	WHITESIDE	39	39
CONTRACT NO.				
PROJECT 7164 ILLINOIS FED. AID PROJECT				