

PLAN

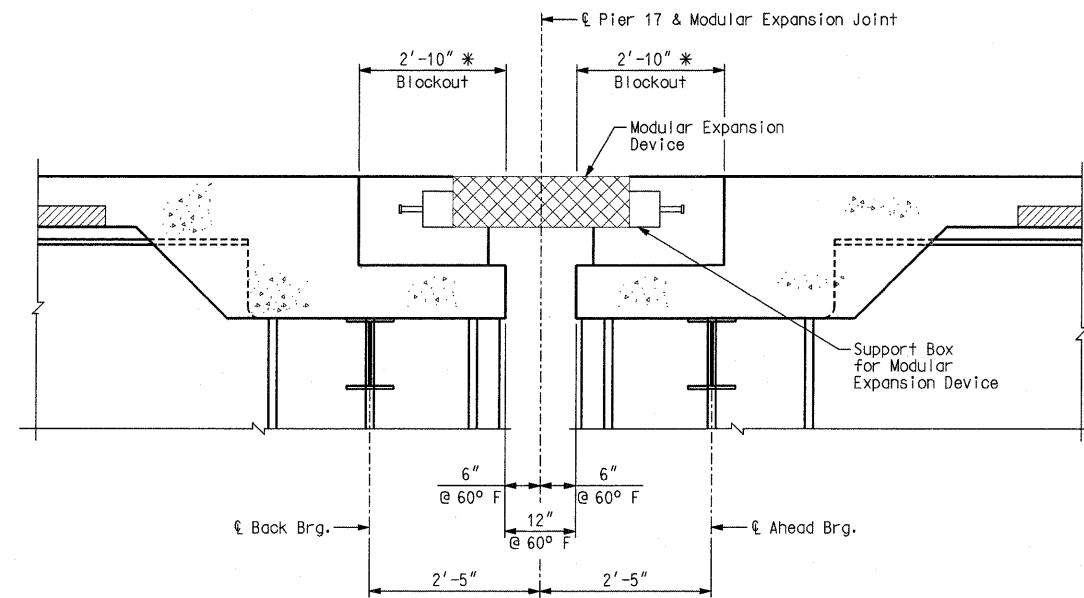

SECTION A-A

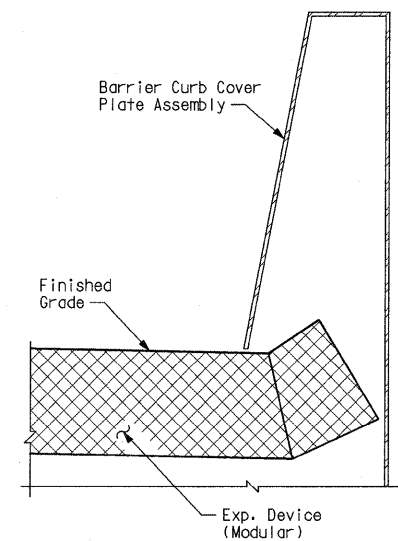

SECTION B-B

Notes:
 Design movements for Modular Expansion Device are 5.77 inches for closing and 8.67 inches for opening (LRFD Service I).
 For slab reinforcing at Expansion Joints, see Sheet No. 100.
 For details of Barrier Curb (Type D), see Sheets Nos. 109 thru 118.
 For details of Barrier Curb Cover Plate Assembly, see Sheets Nos. 119 and 120.
 The cost of materials, fabrication, and installation of Expansion Joint shall be included in the pay item "Modular Expansion Joint".
 * Dimensions dependent upon Modular Expansion Joint selection.
 Contractor is responsible for coordinating any revisions required due to deviations from dimensions shown.
 For additional requirements for Modular Expansion Device, see Special Provisions.

MODULAR EXPANSION JOINT DETAILS WB - PIER 17

Detailed JUL 2009
 Checked JUL 2009

Note: This drawing is not to scale. Follow dimensions.

Sheet No. 123 of 152

s:\dot\0906601\draw_idot\cadd_sheets\structural\B_A6500_123-152_J6I0984C_123.dgn

CONTRACT NO. 76D61	
F.A. ROUTE	SECTION
999	82-1B-2
FED. AID PROJECT	ILLINOIS
COUNTY	ST. CLAIR
USER NAME = jgj11ff	
PLOT SCALE = #SCALE#	
PLOT DATE = 4/14/2010	
DESIGNED -	HNTB
CHECKED -	CMT
DRAWN -	CMT / HNTB
REVISED -	
REVISED -	
REVISED -	
REVISED -	

ILLINOIS APPROACH STRUCTURE
 FOR NEW I-70 MISSISSIPPI RIVER BRIDGE

STATE OF ILLINOIS
 DEPARTMENT OF TRANSPORTATION

MISSOURI HIGHWAYS
 AND TRANSPORTATION COMMISSION

HNTB
 715 KIRK DRIVE
 KANSAS CITY, MO 64105
 TELEPHONE (816) 472-1201
 CERTIFICATE OF AUTHORITY
 NO. 001270

CMT
 CRAWFORD, MURPHY & TILLY, INC.
 2750 WEST WASHINGTON STREET
 SPRINGFIELD, IL 62702
 TELEPHONE (217) 787-8050
 ENGINEERING CORPORATION - 000631