

F.A.U. RTE.	SECTION	COUNTY	TOTAL SHEETS	SHEET NO.
1321	(31&72S)RS-8	DUPAGE	37	6
STA. 105+00		TO STA. 265+89		
FED. ROAD DIST. NO.	ILLINOIS	FED. AID PROJECT		
CONTRACT NO. 62703				

IL 19 (IRVING PARK RD)

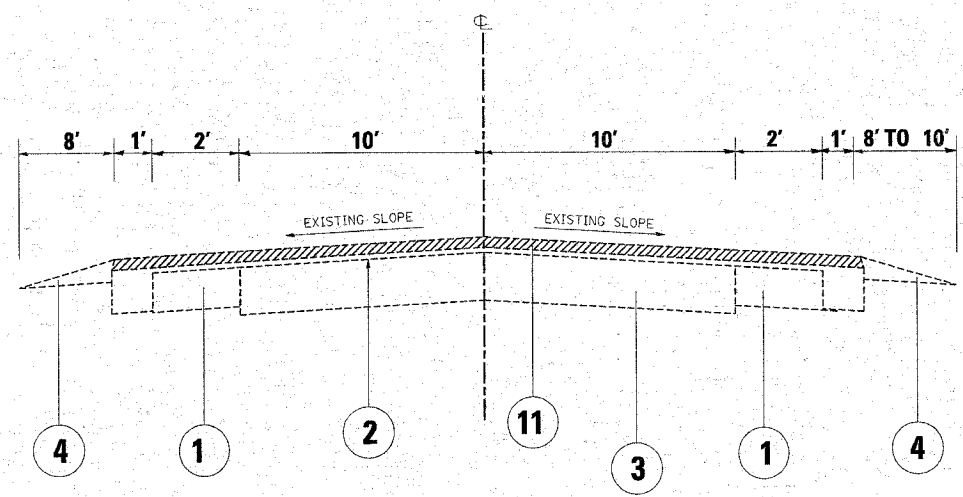

NOTE (RT SIDE ONLY):  
 10' P.C.C. SHOULDER  
 WITH B-6.12 C&G  
 STA. 111+08 TO STA. 112+62

EXISTING TYPICAL CROSS SECTION  
 STA. 106+02 TO STA. 106+40  
 STA. 109+68 TO STA. 115+79

IL 19 (IRVING PARK RD)

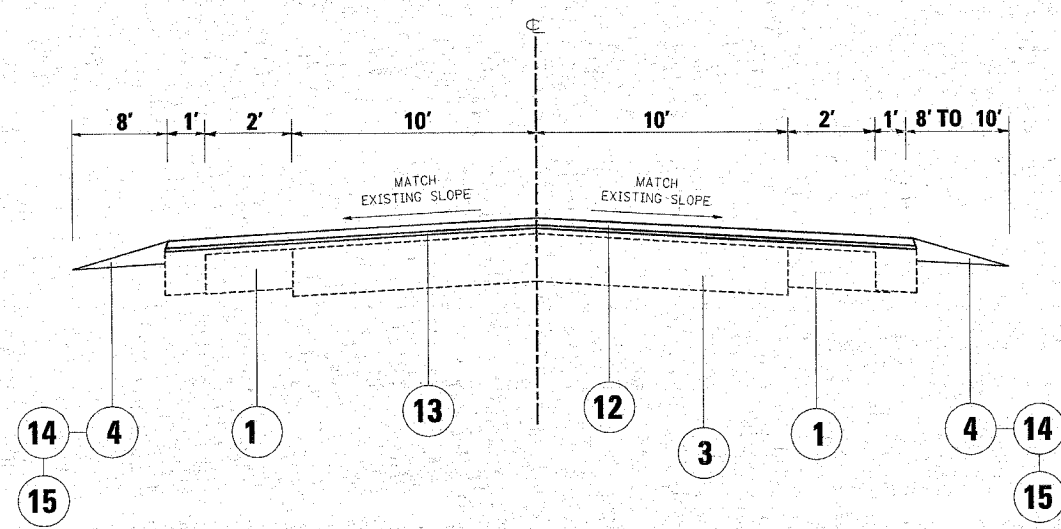

NOTE (RT SIDE ONLY):  
 10' P.C.C. SHOULDER  
 WITH B-6.12 C&G  
 STA. 111+08 TO STA. 112+62

PROPOSED TYPICAL CROSS SECTION  
 STA. 106+02 TO STA. 106+40  
 STA. 109+68 TO STA. 115+79

LEGEND

- ① EXISTING HMA CONCRETE WIDENING, 8-10"
- ② EXISTING HMA CONCRETE OVERLAY, VARIES 3-6"
- ③ EXISTING PORTLAND CEMENT CONCRETE 9"-7"-9"
- ④ EXISTING AGGREGATE WEDGE SHOULDER, TYPE B
- ⑤ EXISTING HMA SHOULDER
- ⑥ EXISTING SUB-BASE GRANULAR MATERIAL
- ⑦ EXISTING POROUS GRANULAR EMBANKMENT
- ⑧ EXISTING CONCRETE CURB AND GUTTER, TYPE B-6.12
- ⑨ EXISTING CONCRETE CURB AND GUTTER, TYPE B-6.24
- ⑩ EXISTING PORTLAND CEMENT CONCRETE SIDEWALK, 5"
- ⑪ PROP. HMA SURFACE REMOVAL, 2 1/4"
- ⑫ PROP. HMA SURFACE COURSE, MIX "D" N70, 1-1/2"
- ⑬ PROP. POLYMERIZED LEVELING BINDER (MACHINE METHOD), IL-4.75, N50, 3/4"
- ⑭ PROP. AGGREGATE WEDGE SHOULDERS, TYPE B
- ⑮ PROP. GRADING & SHAPING SHOULDERS
- ⑯ PROP. COMB. CURB & GUTTER REMOVAL & REPLACEMENT (LOCATIONS TO BE DETERMINED BY THE ENGINEER)
- ⑰ PROP. SIDEWALK REMOVAL & REPLACEMENT (LOCATIONS TO BE DETERMINED BY THE ENGINEER)

REVISIONS	
NAME	DATE

ILLINOIS DEPARTMENT OF TRANSPORTATION  
 ILLINOIS ROUTE 19 (IRVING PARK ROAD)  
 WO MITCHELL BLVD. TO BAKER DR.  
 EXISTING AND PROPOSED  
 TYPICAL SECTIONS

SCALE: VERT. \_\_\_\_\_  
 HORIZ. \_\_\_\_\_  
 DATE \_\_\_\_\_

DRAWN BY \_\_\_\_\_  
 CHECKED BY \_\_\_\_\_