

F.A.I. RTE.	SECTION	COUNTY	TOTAL SHEETS	SHEET NO.
1321	(31&72S)RS-8	DUPAGE	37	14
STA. 105+00		TO STA. 265+89		
FED. ROAD DIST. NO.	ILLINOIS	FED. AID PROJECT		

CONTRACT NO. 62703

IL 19 (IRVING PARK RD)

NOTE (LT SIDE ONLY):  
B-6.12 C&G WITH  
10' BITUMINOUS SHOULDER  
STA. 262+50 TO STA. 265+89

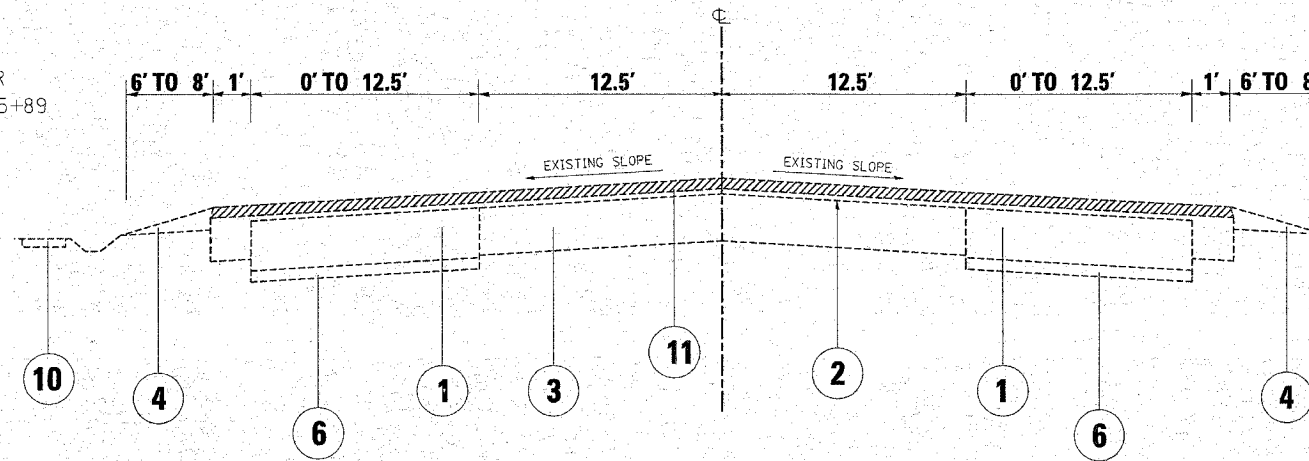

EXISTING TYPICAL CROSS SECTION  
STA. 229+12 TO STA. 265+89

IL 19 (IRVING PARK RD)

NOTE (LT SIDE ONLY):  
B-6.12 C&G WITH  
10' BITUMINOUS SHOULDER  
STA. 262+50 TO STA. 265+89

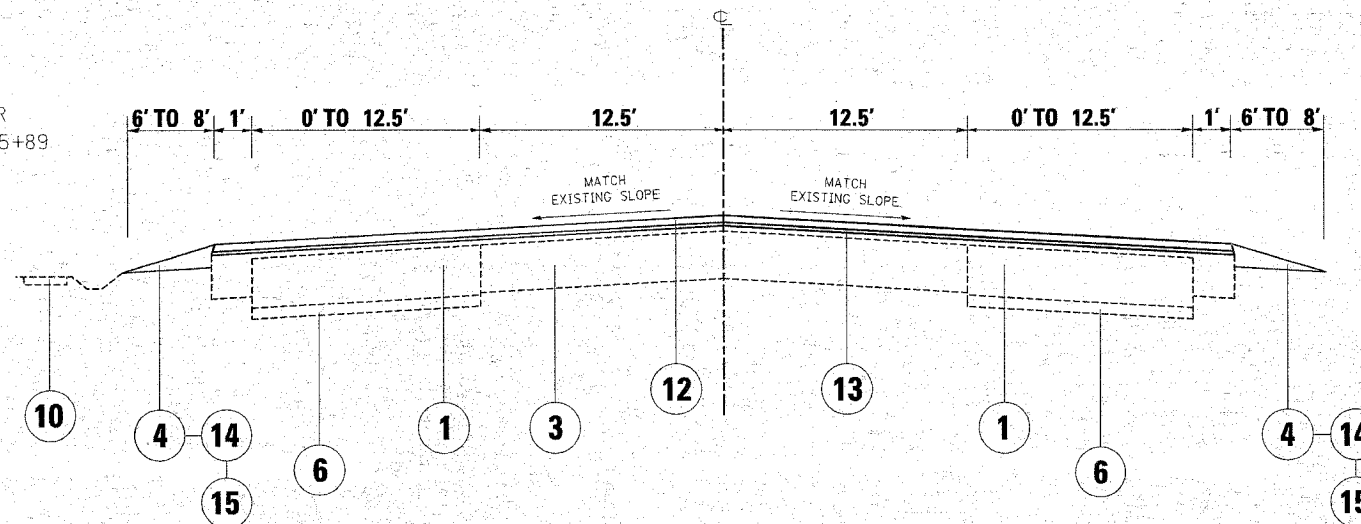

PROPOSED TYPICAL CROSS SECTION  
STA. 229+12 TO STA. 265+89

LEGEND

- ① EXISTING HMA CONCRETE WIDENING, 8-10"
- ② EXISTING HMA CONCRETE OVERLAY, VARIES 3-6"
- ③ EXISTING PORTLAND CEMENT CONCRETE 9"-7"-9"
- ④ EXISTING AGGREGATE WEDGE SHOULDER, TYPE B
- ⑤ EXISTING HMA SHOULDER
- ⑥ EXISTING SUB-BASE GRANULAR MATERIAL
- ⑦ EXISTING POROUS GRANULAR EMBANKMENT
- ⑧ EXISTING CONCRETE CURB AND GUTTER, TYPE B-6.12
- ⑨ EXISTING CONCRETE CURB AND GUTTER, TYPE B-6.24
- ⑩ EXISTING PORTLAND CEMENT CONCRETE SIDEWALK, 5"
- ⑪ PROP. HMA SURFACE REMOVAL, 2 1/4"
- ⑫ PROP. HMA SURFACE COURSE, MIX "D" N70, 1-1/2"
- ⑬ PROP. POLYMERIZED LEVELING BINDER (MACHINE METHOD), IL-4.75, N50, 3/4"
- ⑭ PROP. AGGREGATE WEDGE SHOULDERS, TYPE B
- ⑮ PROP. GRADING & SHAPING SHOULDERS
- ⑯ PROP. COMB. CURB & GUTTER REMOVAL & REPLACEMENT (LOCATIONS TO BE DETERMINED BY THE ENGINEER)
- ⑰ PROP. SIDEWALK REMOVAL & REPLACEMENT (LOCATIONS TO BE DETERMINED BY THE ENGINEER)

REVISIONS	
NAME	DATE

ILLINOIS DEPARTMENT OF TRANSPORTATION  
ILLINOIS ROUTE 19 (IRVING PARK ROAD)  
W/O MITCHELL BLVD. TO BAKER DR.  
EXISTING AND PROPOSED  
TYPICAL SECTIONS

SCALE: VERT. \_\_\_\_\_  
HORIZ. \_\_\_\_\_  
DATE \_\_\_\_\_ DRAWN BY \_\_\_\_\_  
CHECKED BY \_\_\_\_\_