

06-15-12 LETTING ITEM 129

FOR INDEX OF SHEETS AND HIGHWAY  
STANDARDS, SEE SHEET 2.

STATE OF ILLINOIS  
DEPARTMENT OF TRANSPORTATION  
DIVISION OF HIGHWAYS

**PLANS FOR PROPOSED  
BRIDGE PAINTING  
FAI ROUTE 72 (I-72)  
SECTION (86-9) BRIDGE PAINTING  
SCOTT COUNTY  
C96-060-12 / D96-060-12**

CONTRACT: 72F43  
SHEET 1 OF 6  
\*6+1=7

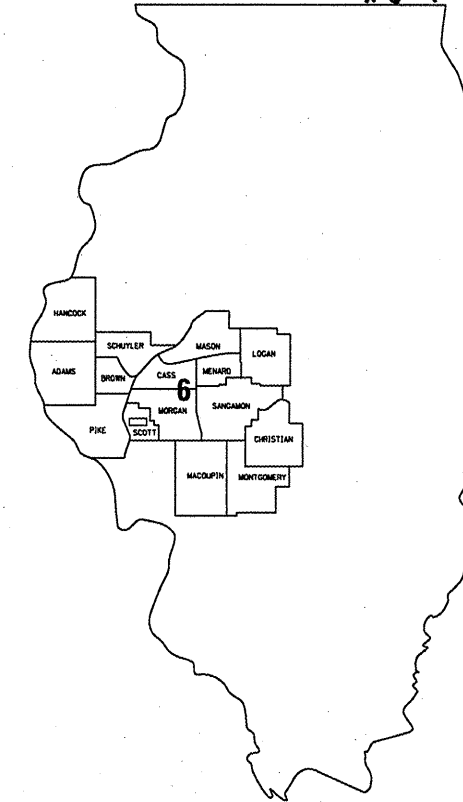

LOCATION OF SECTION INDICATED THUS:

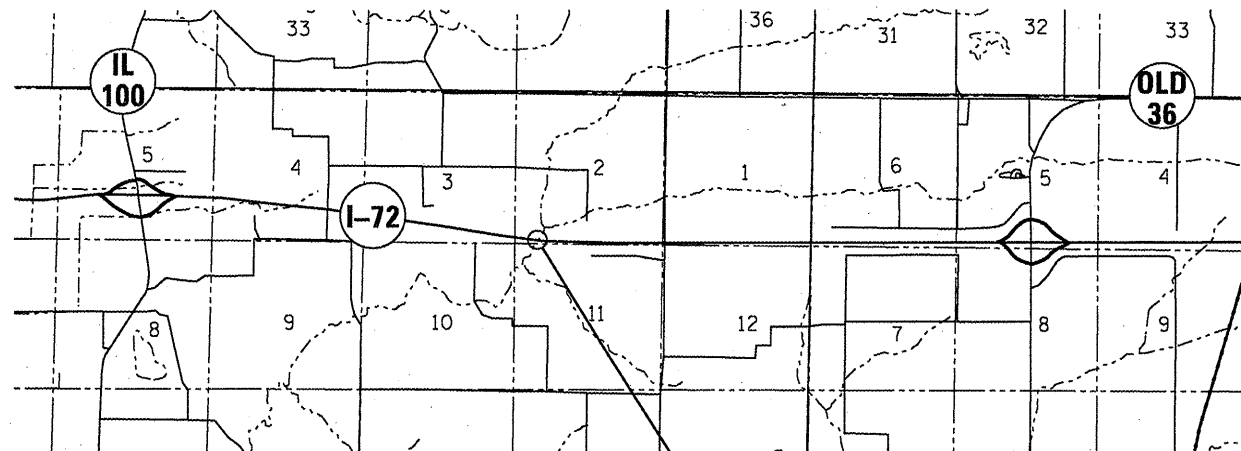

086-0031 (I-72 EB)  
086-0032 (I-72 WB)

**J. U. L. I. E.**  
**JOINT UTILITY LOCATION INFORMATION FOR EXCAVATION**  
1-800-892-0123

BRIDGE INSPECTION ENGINEER: DAVE COPENBARGER  
PHONE: (217) 785-5306  
BRIDGE MAINTENANCE ENGINEER: STEVE BERAN  
PHONE: (217) 785-9290

NET LENGTH OF SEC 375 FT=0.07 MILE

**CONTRACT NO. 72F43**

STATE OF ILLINOIS  
DEPARTMENT OF TRANSPORTATION  
DIVISION OF HIGHWAYS

SUBMITTED APRIL 4 20 12

Roger L. Driskell  
DEPUTY DIRECTOR OF HIGHWAYS, REGION FOUR ENGINEER

May 11 20 12  
John D. Baranzelli P.E.  
ENGINEER OF DESIGN AND ENVIRONMENT

May 11 20 12  
William R. Frey Jr.  
DIRECTOR, DIVISION OF HIGHWAYS

PRINTED BY AUTHORITY OF THE STATE OF ILLINOIS

INDEX OF SHEETS:

- 1 - COVER SHEET
- 2 - INDEX, HIGHWAY STANDARDS, & GENERAL NOTES
- 3 - SUMMARY OF QUANTITIES
- 4 THRU 6A- TYPICAL BRIDGE PLANS

STANDARDS

- 701101-02
- 701106-02
- 701400-05
- 701406-06
- 701901-02

GENERAL NOTES:

STRUCTURE NO 1 - SN 086-0031, I-72 EB OVER PLUM CREEK LOCATED 2.75 MILES EAST OF THE IL 100 INTERCHANGE. CLEANING AND PAINTING OF THE EXISTING STRUCTURAL STEEL SHALL BE AS SPECIFIED IN THE SPECIAL PROVISIONS FOR "CLEANING AND PAINTING EXISTING STEEL STRUCTURES". ALL BEAMS, BEARING AND OTHER STRUCTURAL STEEL WITHIN 10' (MEASURED ALONG THE BEAM) OF EITHER SIDE OF DECK JOINTS, AND ALSO THE INTERIOR AND EXTERIOR OF BOTH FASCIA BEAMS SHALL BE CLEANED PER NEAR WHITE BLAST CLEANING PER SSPC-SP10. ALL EXISTING STEEL CLEANED SHALL BE PAINTED ACCORDING TO THE REQUIREMENTS OF PAINT SYSTEM 1 - OZ/E/U. THE COLOR OF THE FINAL FINISH COAT SHALL BE GREEN, MUNSELL NO 7.5G 4/8.

STRUCTURE NO 2 - SN 086-0032, I-72 WB OVER PLUM CREEK LOCATED 2.75 MILES EAST OF THE IL 100 INTERCHANGE. CLEANING AND PAINTING OF THE EXISTING STRUCTURAL STEEL SHALL BE AS SPECIFIED IN THE SPECIAL PROVISIONS FOR "CLEANING AND PAINTING EXISTING STEEL STRUCTURES". ALL BEAMS, BEARING AND OTHER STRUCTURAL STEEL WITHIN 10' (MEASURED ALONG THE BEAM) OF EITHER SIDE OF DECK JOINTS, AND ALSO THE INTERIOR AND EXTERIOR OF BOTH FASCIA BEAMS SHALL BE CLEANED PER NEAR WHITE BLAST CLEANING PER SSPC-SP10. ALL EXISTING STEEL CLEANED SHALL BE PAINTED ACCORDING TO THE REQUIREMENTS OF PAINT SYSTEM 1 - OZ/E/U. THE COLOR OF THE FINAL FINISH COAT SHALL BE GREEN, MUNSELL NO 7.5G 4/8

THE USE OF AIR MONITORS WILL BE REQUIRED AT BOTH STRUCTURES. A MINIMUM OF 2 MONITORS WILL BE REQUIRED AT EACH BRIDGE TO MONITOR ABRASIVE BLASTING OPERATIONS AT THIS SITE, SEE SPECIAL PROVISIONS FOR "CONTAINMENT AND DISPOSAL OF LEAD PAINT CLEANING RESIDUES".

THE SSPC-QP-1 AND SSPC-QP2 PAINTING CONTRACTOR CERTIFICATIONS WILL BE REQUIRED FOR THESE BRIDGES.

<b>STATE OF ILLINOIS DEPARTMENT OF TRANSPORTATION DIVISION OF HIGHWAYS DISTRICT 6</b>	
EXAMINED <u>March 30</u>	20 <u>12</u>
<u>William M. Boyer</u> ENGINEER OF OPERATIONS	
EXAMINED <u>APRIL 3</u>	20 <u>12</u>
<u>Jimmy Ford</u> ENGINEER OF PROJECT IMPLEMENTATION	
EXAMINED <u>APRIL 4</u>	20 <u>12</u>
<u>John C. Wynn</u> ENGINEER OF PROGRAM DEVELOPMENT	

QUANTITIES  
FAI 72 (I-72)  
(86-9) BRIDGE PAINTING  
SCOTT COUNTY



STATE OF ILLINOIS  
DEPARTMENT OF TRANSPORTATION

PROJECT NO.	DISTRICT	COUNTY	TOTAL SHEETS	SHEET NO.
FA 408	86-9B-3	Scott	25	5
SHEET NO. 1 21 SHEETS				

Bench Mark: TBL #12 RR spike in roof of 90' tree on West bank of Plum Creek, 1400' South of E. FA Rte. 408 Elev. 403.63  
No exist. structure

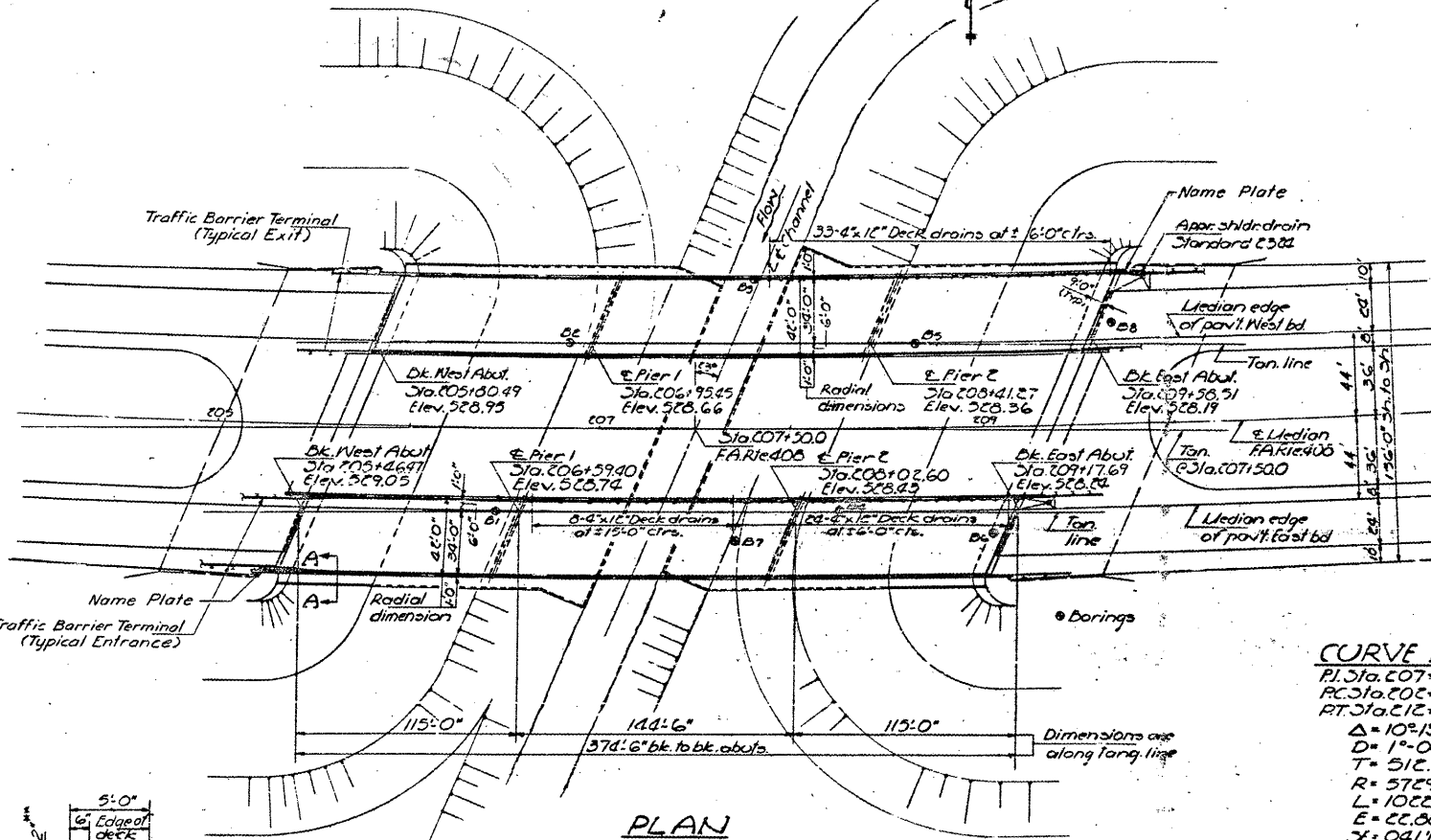
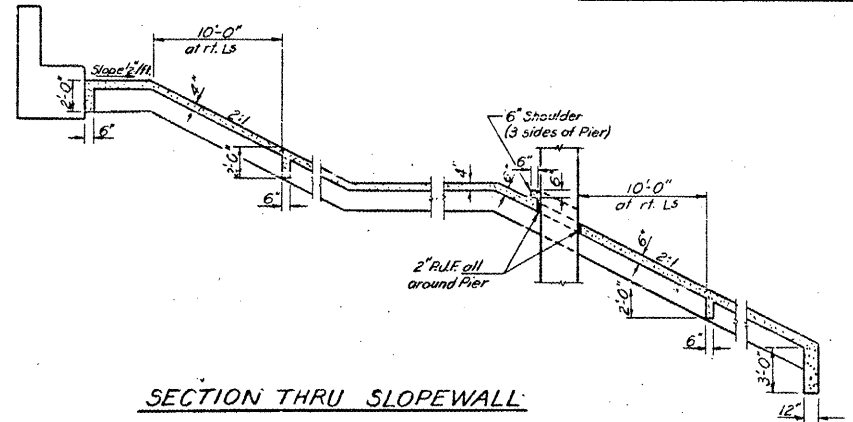
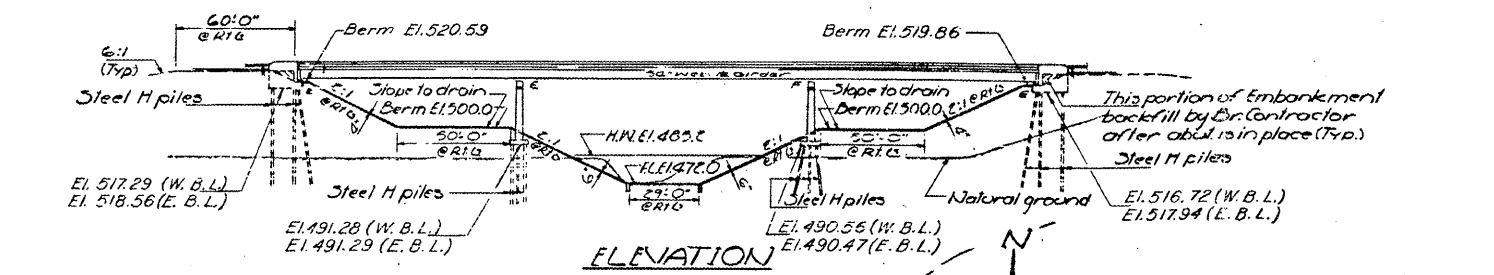

(\*) - Structure Number to be supplied by District.

STATION 207+50.00  
BUILT 197 BY  
STATE OF ILLINOIS  
FA. R. 408 SEC. 86-9B-3  
FA. PROJ. EBF-408-1(40)  
LOADING HS20  
(\*) STR. NO. \_\_\_\_\_

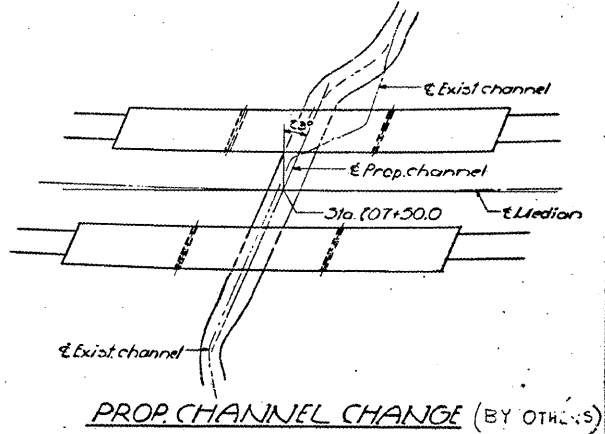
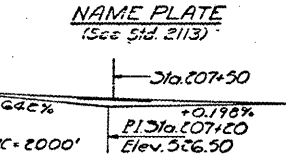

**CURVE DATA**  
P.I. Sta. 207+23.68  
P.C. Sta. 205+11.09  
P.T. Sta. 212+35.54  
Δ = 10° 15' 28"  
D = 1° 00' 00"  
T = 512.84'  
R = 5729.58'  
L = 1022.45'  
E = 22.88'  
X = 0.41'  
SE. Attained:  
Sta. 200+51.09 - Sta. 202+91.09  
Sta. 211+55.54 - Sta. 213+92.54

**WATERWAY INFORMATION**  
Drainage Area 11,568 Acres  
Required Opening 730 Sq. Ft.  
Proposed Opening 730 Sq. Ft.  
Q(50) = 4500 cfs Created Head 0.14'  
Q(100) = 3675 cfs Created Head 0.20'  
H.W. Elev. (100) 406.3

**DESIGN STRESSED**  
f'c = 3,500 psi  
fy = 60,000 psi Reinforcement  
fs = 20,000 psi Struct. Steel

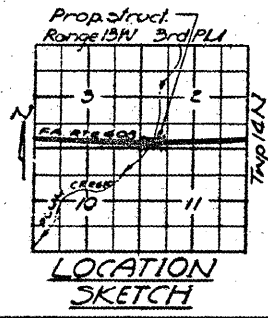

**PROJECT EBF-408-1(40)**  
**GENERAL PLAN & ELEVATION**  
**FA. R. 408 OVER PLUM CREEK**  
**SECTION 86-9B-3**  
**SCOTT COUNTY**  
**STATION 207+50.00**

DESIGNED	APR 1976	EXAMINED	DEC 23 1976
CHECKED	JAN 1976	PASSED	
DRAWN	JAN 1976	APPROVED	
CHECKED	JAN 1976		

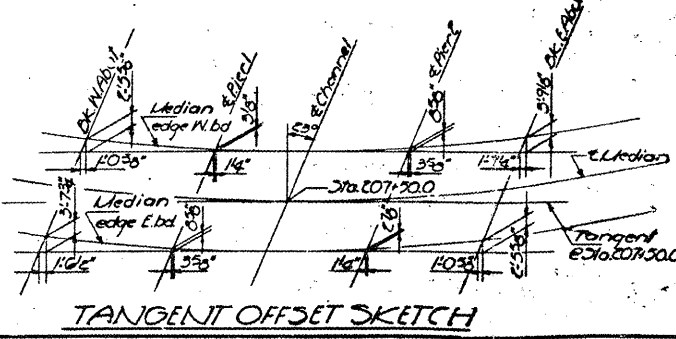

LOADING HS20-44

FOR INFORMATION ONLY

TYPICAL BRIDGE PLANS  
FAI 72 (I-72)  
(86-9) BRIDGE PAINTING  
SCOTT COUNTY

STATE OF ILLINOIS  
DEPARTMENT OF TRANSPORTATION

DATE	SECTION	AMOUNT	TOTAL SHEETS	SHEET NO.
11-4-08	86-9B-3	Scott	25	15
SHEET NO. 11				
21 SHEETS				

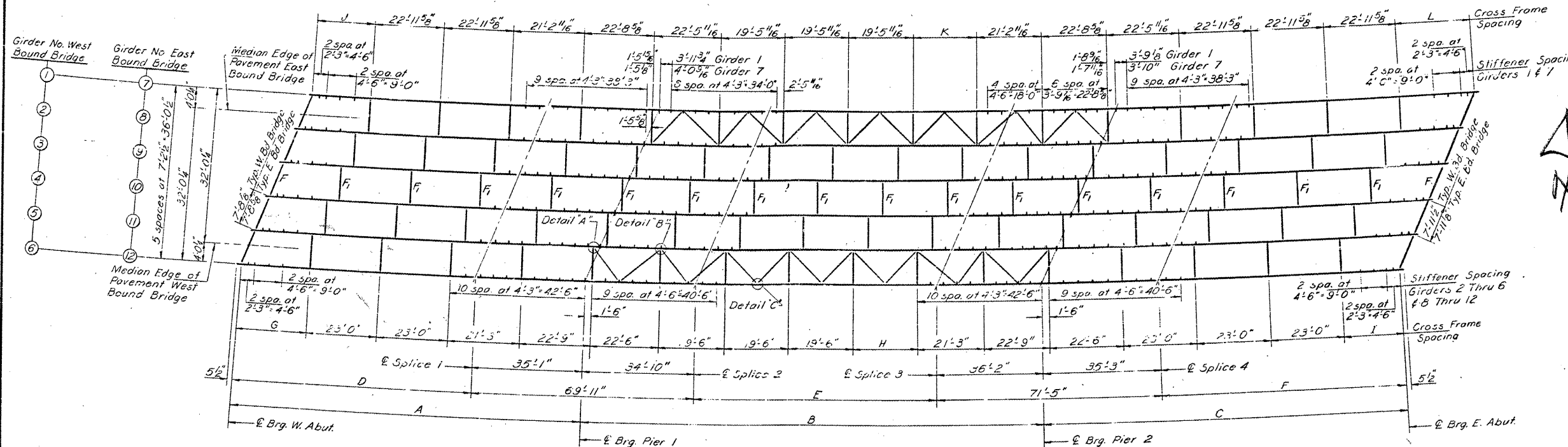

FRAMING PLAN

NOTES:  
Work this Sheet with Sheet 12  
All transverse dimensions are radial.  
All longitudinal dimensions are along E Girder.

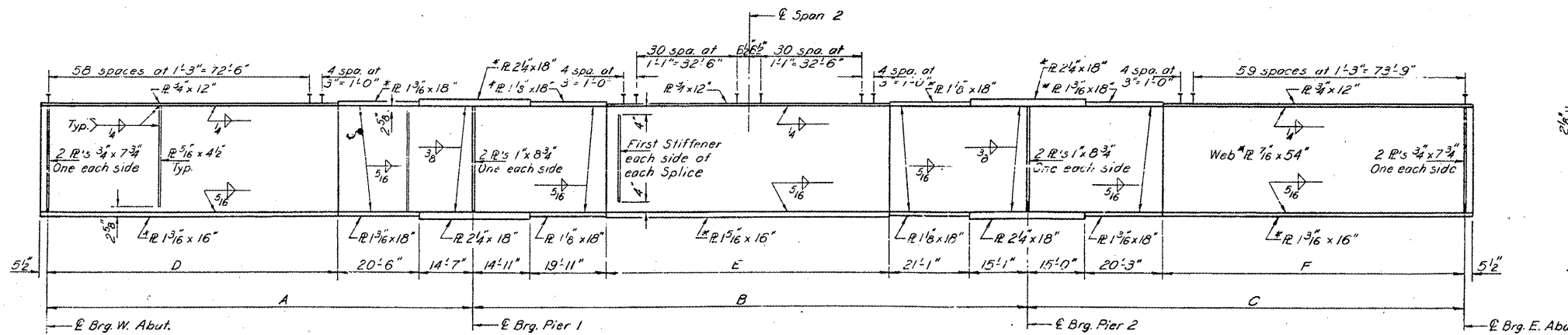

ELEVATION

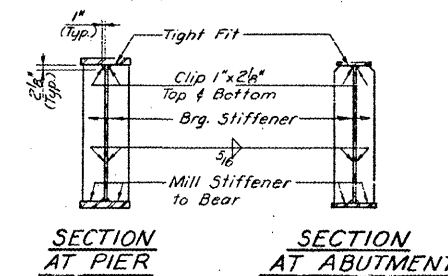

SECTION AT PIER

SECTION AT ABUTMENT

DESIGNED	<i>[Signature]</i>
CHECKED	<i>[Signature]</i>
DRAWN	R. R. Summer
CHECKED	G. S. W. <i>[Signature]</i>

EXAMINED	<i>[Signature]</i>
PASSED	
APPROVED	

\* Supplemental Requirements  
for Notch Toughness Zone 2

FOR INFORMATION ONLY

STRUCTURAL STEEL  
F.A. RT. 408 SEC. 86-9B-3  
SCOTT COUNTY  
STA. 207+50.00

FOR INFORMATION ONLY

TYPICAL BRIDGE PAINS  
FAI 72 (I-72)  
(86-9)BRIDGE PAINTING  
SCOTT COUNTY

STATE OF ILLINOIS  
DEPARTMENT OF TRANSPORTATION

DATE	BY	CHECKED	TOTAL SHEETS	SHEET NO.
11-28-88	Scott		25	16

21 SHEETS

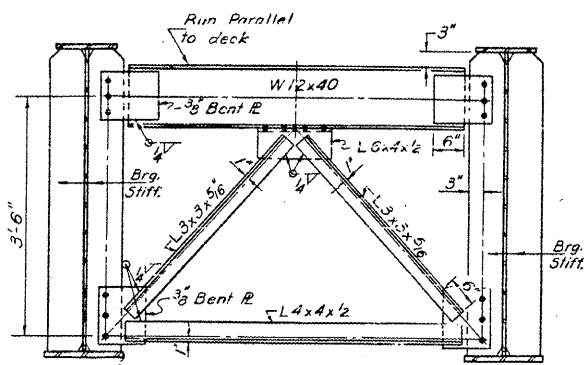

CROSS FRAME F  
20 Required

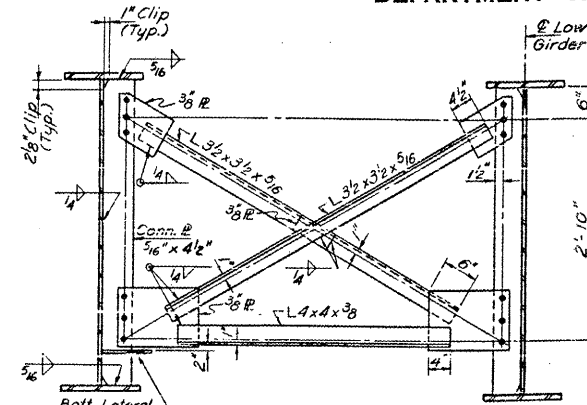

CROSS FRAME F1  
160 Required

Note: 15/16" holes in gusset R's for 3/4" bolts. Hardened washers shall be required over holes in gusset R's.

**DIMENSIONS**

Gir	Dim	Radius	A	B	C	D	E	F	G	H	I	J	K	L
1		5653.56	111'-5 9/16"	144'-10 1/4"	113'-8 1/16"	76'-4 9/16"	73'-10 1/4"	18'-5 1/16"				20'-1 1/16"	19'-9 3/16"	24'-0 1/16"
2		5660.77	111'-5 5/16"	144'-9 9/16"	113'-7 1/16"	76'-4 1/4"	73'-9 13/16"	18'-4 1/16"	22'-11 1/4"	19'-9 19/16"	20'-7 1/16"	20'-0 3/16"	19'-9 3/16"	23'-11 3/16"
3		5667.98	111'-5 1/16"	144'-9 3/8"	113'-7 3/8"	76'-4 1/8"	73'-9 3/8"	18'-4 3/8"	22'-11 1/8"	19'-9 3/8"	20'-7 3/8"	20'-0 3/8"	19'-9 3/8"	23'-11 1/8"
4		5675.18	111'-4 3/4"	144'-9"	113'-7"	76'-3 3/4"	73'-9"	18'-4"	22'-10 3/4"	19'-9"	20'-7"	20'-0 3/4"	19'-9 3/8"	23'-10 3/4"
5		5682.39	111'-4 1/8"	144'-8 3/8"	113'-6 3/8"	76'-3 3/8"	73'-8 3/8"	18'-3 3/8"	22'-10 1/8"	19'-8 3/8"	20'-6 3/8"	20'-0 1/8"	19'-7 3/8"	23'-10 1/8"
6		5689.60	111'-4 1/8"	144'-8 3/8"	113'-6 3/8"	76'-3 3/8"	73'-8 3/8"	18'-3 3/8"	22'-10 1/8"	19'-8 3/8"	20'-6 3/8"	20'-0 1/8"	19'-7 3/8"	23'-10 1/8"
7		5769.56	111'-1 1/4"	144'-3 1/4"	113'-2 3/4"	76'-0 3/4"	73'-3 1/4"	17'-11 3/8"				19'-9 3/8"	19'-3 1/4"	23'-5 1/2"
8		5776.77	111'-0 1/4"	144'-3 1/4"	113'-2 1/4"	75'-11 1/4"	73'-3 1/4"	17'-11 1/4"	22'-6 1/4"	19'-3 1/4"	20'-2 1/4"	19'-9 3/8"	19'-2 3/4"	23'-5 1/4"
9		5783.98	111'-0 1/4"	144'-3 1/4"	113'-1 1/4"	75'-11 1/4"	73'-3 1/4"	17'-10 1/4"	22'-6 1/4"	19'-3 1/4"	20'-1 1/4"	19'-9 3/8"	19'-2 3/4"	23'-4 1/4"
10		5791.18	111'-0 1/8"	144'-2 1/8"	113'-1 3/8"	75'-11 1/8"	73'-2 1/4"	17'-10 3/8"	22'-6 1/8"	19'-2 1/4"	20'-1 3/8"	19'-8 3/8"	19'-2 1/4"	23'-4 3/8"
11		5798.39	111'-0 3/16"	144'-2 3/16"	113'-1 1/16"	75'-11 3/16"	73'-2 3/16"	17'-10 1/16"	22'-6 3/16"	19'-2 3/16"	20'-1 1/16"	19'-8 1/16"	19'-1 3/4"	23'-3 1/16"
12		5805.60	110'-11 1/16"	144'-1 1/16"	113'-0 3/8"	75'-10 1/16"	73'-1 1/16"	17'-9 3/4"	22'-5 5/16"	19'-1 1/16"	20'-0 3/8"	19'-8 1/16"	19'-1 3/4"	23'-3 1/16"

TOP OF WEB ELEVATIONS

Gir	E Brg. W. Abut.	E Splice 1	E Brg. Pier 1	E Splice 2	E Splice 3	E Brg. Pier 2	E Splice 4	E Brg. E. Abut.
1	526.697	526.494	526.204	526.356	526.212	526.002	526.076	525.965
2	527.001	526.797	526.592	526.658	526.513	526.303	526.377	526.265
3	527.303	527.099	526.894	526.960	526.814	526.604	526.677	526.564
4	527.607	527.402	527.197	527.262	527.116	526.906	526.978	526.864
5	527.910	527.704	527.499	527.564	527.417	527.206	527.278	527.164
6	528.214	528.008	527.802	527.867	527.719	527.507	527.579	527.464
7	528.517	528.311	528.105	528.170	528.022	527.810	527.882	527.767
8	528.821	528.614	528.408	528.473	528.325	528.113	528.185	528.070
9	529.124	528.918	528.712	528.777	528.629	528.417	528.489	528.374
10	529.428	529.221	529.015	529.080	528.932	528.720	528.792	528.677
11	529.731	529.525	529.319	529.384	529.236	529.024	529.096	528.981
12	529.491	529.275	529.059	529.124	528.976	528.764	528.836	528.721

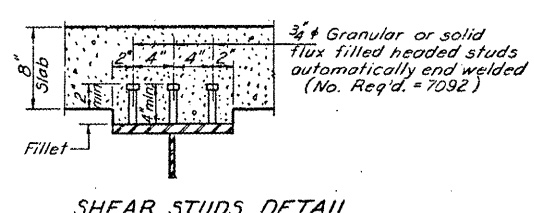
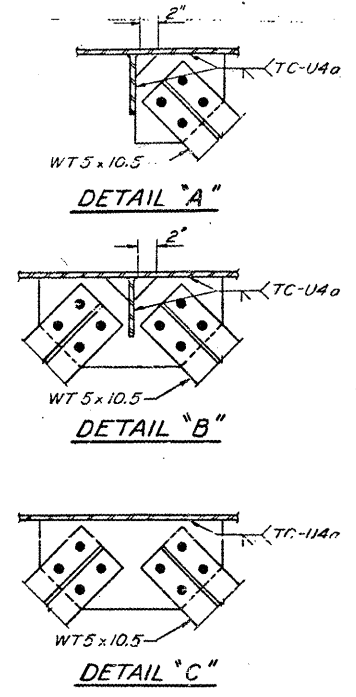
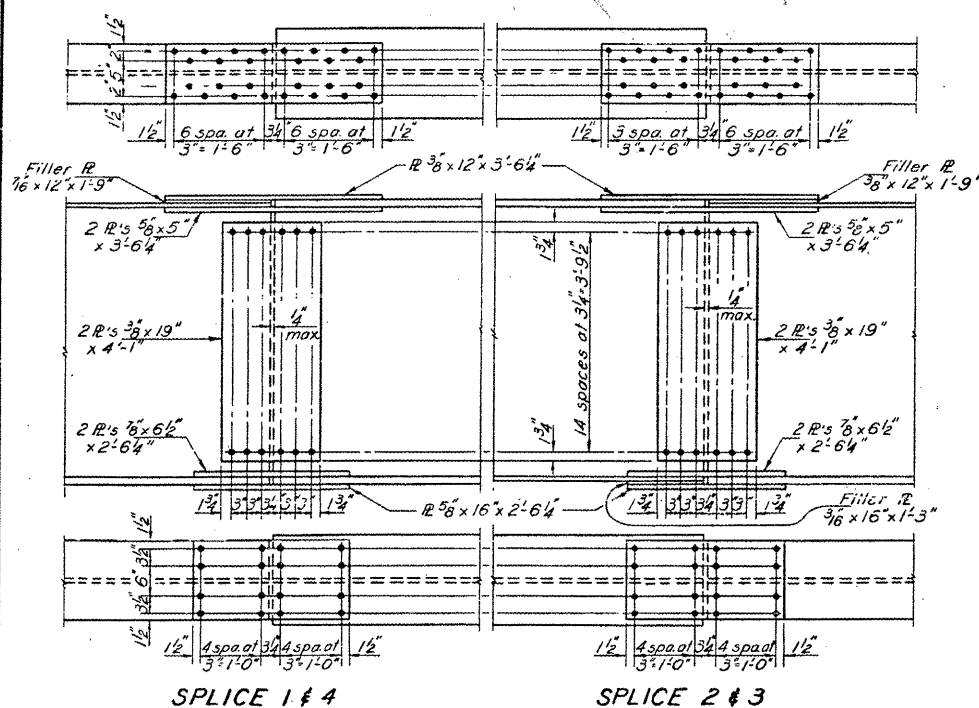

**INTERIOR GIRDER MOMENT TABLE**

	0.4 Sp. 1 or 0.6 Sp. 3	Pier 1 or Pier 2	0.5 Sp. 2
I <sub>s</sub> (in <sup>4</sup> )	25447	69841	26454
I <sub>c</sub> (in <sup>4</sup> )	70679		74840
S <sub>s</sub> (in <sup>3</sup> )	1116	2388	1198
S <sub>c</sub> (in <sup>3</sup> )	1540		1651
Q (k/ft)	.974	.986	.998
M <sub>g</sub> (k)	716	1986	665
f <sub>sg</sub> (ksi)	7.7	9.9	6.7
S <sub>Q</sub> (k/ft)	.437	.437	.437
M <sub>sp</sub> (k)	389	713	435
M <sub>u</sub> (k)	914	980	988
M <sub>imp</sub> (k)	244	241	225
TOTAL (k)	1547	1934	1648
f <sub>s</sub> & f <sub>sg</sub> (ksi)	12.1	9.7	12.0
f <sub>s</sub> TOTAL (ksi)	19.8	19.6	18.7
VR (k)	58.5		50.1

**INTERIOR GIRDER REACTION TABLE**

	Abut.	Pier
R <sub>g</sub> (k)	56.4	207.8
R <sub>u</sub> (k)	42.5	80.5
Imp. (k)	8.9	15.9
R <sub>TOTAL</sub> (k)	107.8	304.2

I<sub>s</sub> and S<sub>s</sub> are the moment of inertia and section modulus of the steel section.  
I<sub>c</sub> and S<sub>c</sub> are the moment of inertia and section modulus of the composite section used in computing I<sub>s</sub>.  
VR is the maximum impact shear range in span used to determine shear connector spacing.

DESIGNED: *[Signature]*  
CHECKED: *[Signature]*  
DRAWN: R. P. Sumner  
CHECKED: GSW *[Signature]*

EXAMINED: *[Signature]*  
PASSED: \_\_\_\_\_  
APPROVED: \_\_\_\_\_

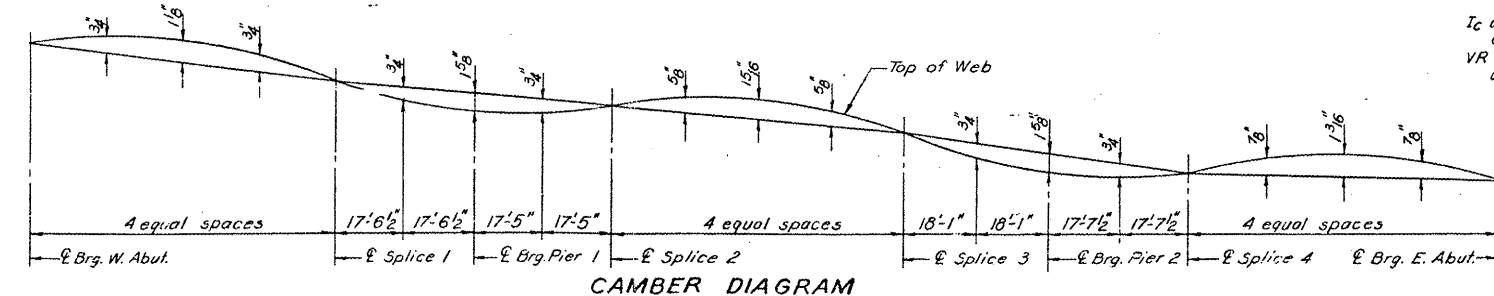

FOR INFORMATION ONLY  
**STRUCTURAL STEEL DETAILS**  
FA. RT.408 SEC.86-9B-3  
SCOTT COUNTY  
STA. 207+50.00

FOR INFORMATION ONLY

TYPICAL BRIDGE PALMS  
FAI 72 (I-72)  
(86-9)BRIDGE PAINTING  
SCOTT COUNTY

STATE OF ILLINOIS  
DEPARTMENT OF TRANSPORTATION

ROUTE NO.	SECTION
411	3-9B-3(1)
FED. ROAD DIST. NO.	ILLINOIS

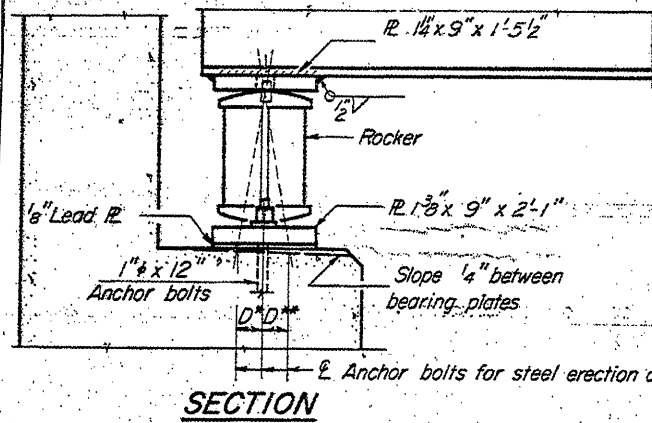

SECTION

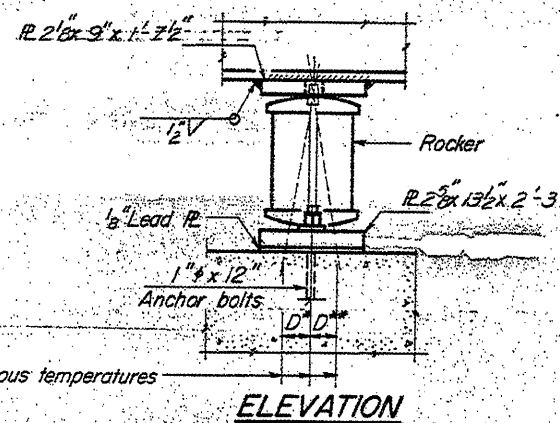

ELEVATION

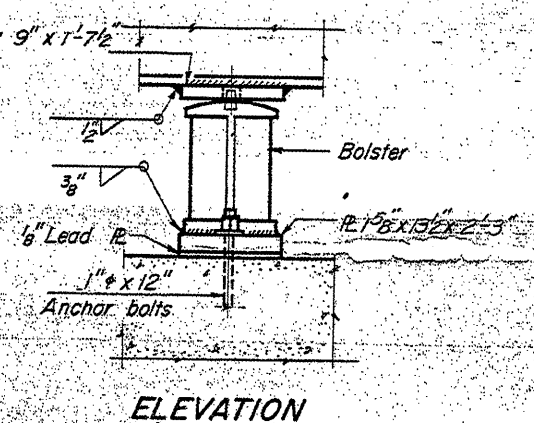

ELEVATION

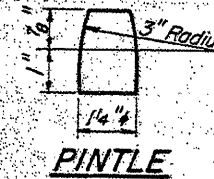

PINTLE

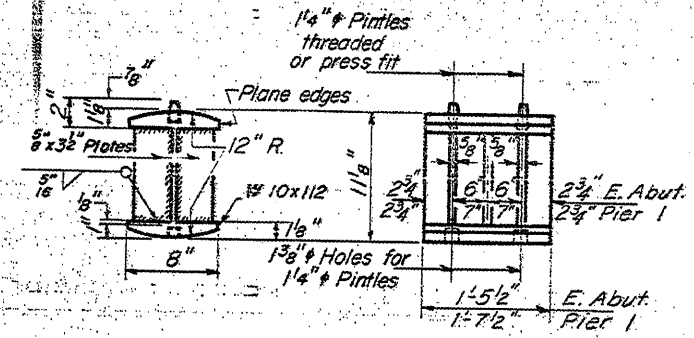

ROCKER AT  
E. ABUTMENT & PIER 1

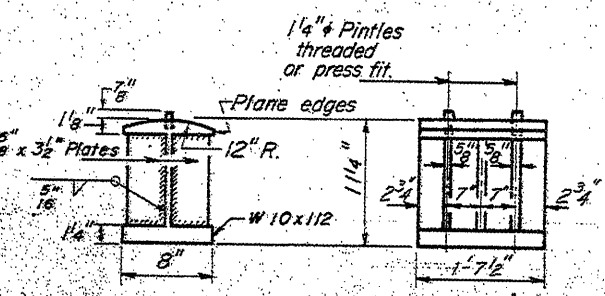

BOLSTER AT  
PIER 2

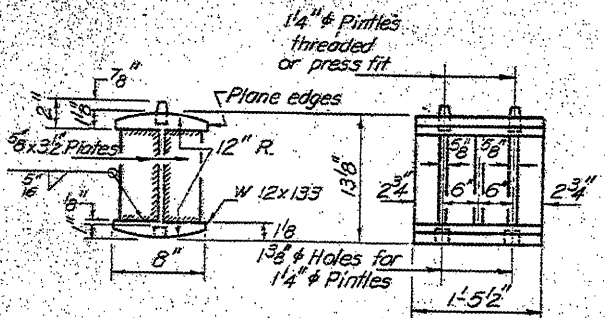

ROCKER AT  
W. ABUTMENT

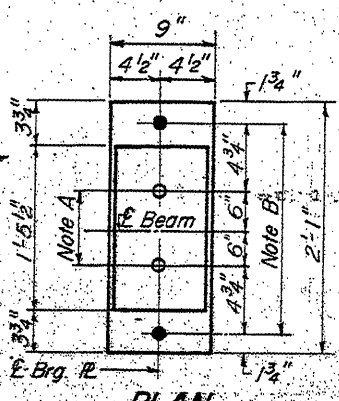

PLAN

AT ABUTMENTS

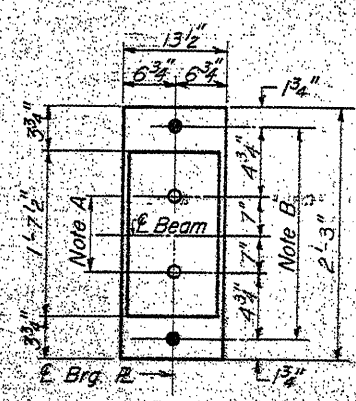

PLAN

AT PIER 1

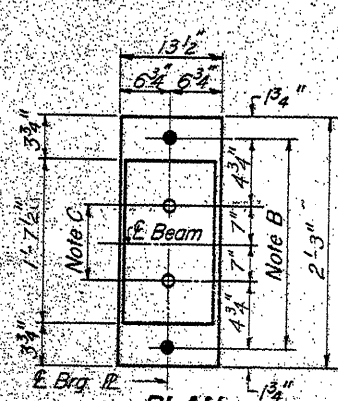

PLAN

AT PIER 2

NOTE A  
1 1/2" Holes - 1" deep in top IR  
for pintles. Thread or press-fit  
pintles into bottom IR.

NOTE B  
1 1/2" Holes for 1" anchor bolts.  
1 1/2 x 2 1/2 x 2 1/2 IR Washers  
under nut.

NOTE C  
1 1/2" Holes 1" deep in top IR  
only for 1 1/4" pintles.

BEARING ASSEMBLY DETAILS

NOTES ON SETTING OF ANCHOR BOLTS AT EXP. BRGS.

(Side of brg. away from fixed brg.)  
D\* = 1/8" per each 100' of expansion for  
every 15° fall below the normal temp.  
of 50°F.  
(Side of brg. toward fixed brg.)  
D\*\* = 1/8" per each 100' of expansion for  
every 15° rise above the normal temp.  
of 50°F.  
If beams have been erected and dimensions D\* or D\*\*  
determined, holes shall be drilled and anchor bolts shall  
be grouted in place. All fixed anchor bolts may be built  
into the masonry.

FOR INFORMATION ONLY

TYPICAL BRIDGE PALNS  
FAI 72 (I-72)  
(86-9) BRIDGE PAINTING  
SCOTT COUNTY