

LEGEND

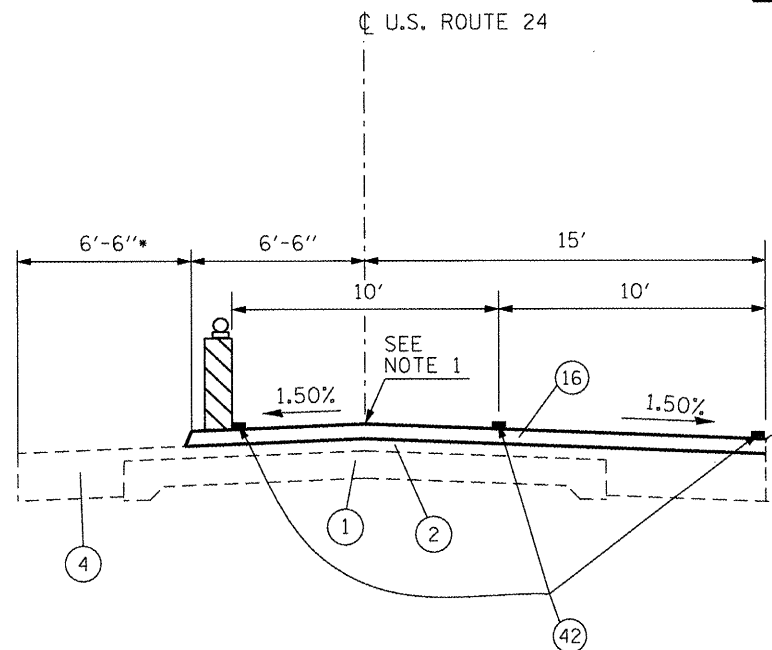

•AFTER PAVT. REM. REQUIRED FOR STORM SEWER INSTALLATION

**PRE-STAGE 3
TYPICAL SECTION FOR TEMPORARY HMA BINDER BUILD-UP
STA. 885+40 TO STA. 887+80**

NOTES

1. PROFILE FOR THE TEMPORARY BUILD-UP AT US 24 CENTERLINE SHALL BE 2" BELOW THE PROPOSED PROFILE.
2. TAPER LEADING INTO STAGE CONSTRUCTION TRAFFIC CONTROL SHALL BE AT A 50:1 TAPER RATE. THE LENGTH OF THE TAPER SHALL BE CALCULATED ACCORDING TO THE FOLLOWING:
 $L = W \times \text{TAPER RATE}$, WHERE L= MIN TAPER LENGTH (FT) AND W= WIDTH (FT).
3. BARRICADES SHALL BE LIGHTED VERTICAL BARRICADES AT 50' CENTERS.
4. TRAFFIC CONTROL AND PROTECTION, STANDARD 701501, SHALL BE USED DURING PAVING OPERATIONS.
5. TEMPORARY STRIPING AND BARRICADES SHALL BE INSTALLED AS SHOWN HERE UPON COMPLETION OF THE PAVING OPERATIONS TO ALLOW FOR THE WORK IN STAGE 3A.
6. USE TRAFFIC CONTROL AND PROTECTION, STANDARD 701501, FOR DAYTIME CLOSURES.

EXISTING

- 1 PORTLAND CEMENT CONCRETE PAVEMENT, 9"-6"-9"
- 2 BITUMINOUS CONCRETE SURFACE OVERLAY, 3"-5"
- 3 BITUMINOUS BASE COURSE WIDENING, 9"
- 4 PORTLAND CEMENT CONCRETE BASE COURSE WIDENING
- 6 PORTLAND CEMENT CONCRETE OR BRICK SIDEWALK, 4"-5"
- 7 CONCRETE CURB

PROPOSED

- 15 POLYMERIZED HOT-MIX ASPHALT SURFACE COURSE, MIXTURE "D", N50 (1-1/2")
- 16 LEVELING BINDER (MACHINE METHOD), N50
- 17 POLYMERIZED HOT-MIX ASPHALT BINDER COURSE, IL-12.5 N50 (1 1/2" (MIN.))
- 18 POLYMERIZED HOT-MIX ASPHALT BINDER COURSE, IL-12.5 N50 (2 1/4")
- 19 HOT-MIX ASPHALT SURFACE REMOVAL, 1"
- 20 PORTLAND CEMENT CONCRETE PAVEMENT 8-3/4" (JOINTED)
- 21 HOT-MIX ASPHALT SURFACE REMOVAL, VARIABLE DEPTH
- 23 SUB-BASE GRANULAR MATERIAL, TYPE B (8")
- 24 GEOTECHNICAL FABRIC FOR GROUND STABILIZATION
- 25 AGGREGATE SHOULDERS, TYPE B
- 31 COMBINATION CONCRETE CURB AND GUTTER, TYPE B-6.24
- 32 PORTLAND CEMENT CONCRETE SIDEWALK, 4"
- 33 PORTLAND CEMENT CONCRETE SIDEWALK, SPECIAL
- 34 TOPSOIL FURNISH & PLACE, 4"
- 35 SODDING
- 36 SEEDING, CLASS 2A
- 38 HEAVY DUTY EROSION CONTROL BLANKET (SEE SCHEDULE FOR LOCATION & LIMITS)
- 41 PIPE UNDERDRAIN, 6"
- 42 TEMPORARY STRIPING
- 43 AGGREGATE FOR TEMPORARY ACCESS

FILE NAME = miscsheets.dgn	USER NAME = horstkj	DESIGNED -	REVISED -	STATE OF ILLINOIS DEPARTMENT OF TRANSPORTATION	STAGING DETAILS PRE-STAGE 3 TEMPORARY HMA BINDER BUILD-UP			F.A.P. RTE. = 317	SECTION = 16W-1, RS-3	COUNTY = FULTON	TOTAL SHEETS = 347	SHEET NO. = 92
	PLOT SCALE = 7.2279' / in.	DRAWN -	REVISED -		SCALE: _____	SHEET NO. _____	OF _____	SHEETS _____	STA. _____	TO STA. _____	CONTRACT NO. 88795	
	PLOT DATE = 3/15/2012	CHECKED -	REVISED -		FED. ROAD DIST. NO. _____	ILLINOIS FED. AID PROJECT						