

STATE OF ILLINOIS
DEPARTMENT OF TRANSPORTATION

Various Routes
OVD SIN STR REP & REPL 2006-9
Various Counties
Sheet 14 of 89
Contract Number 44904

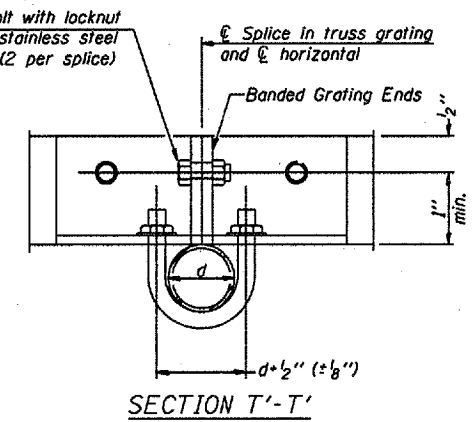
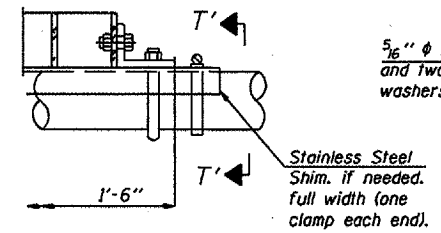
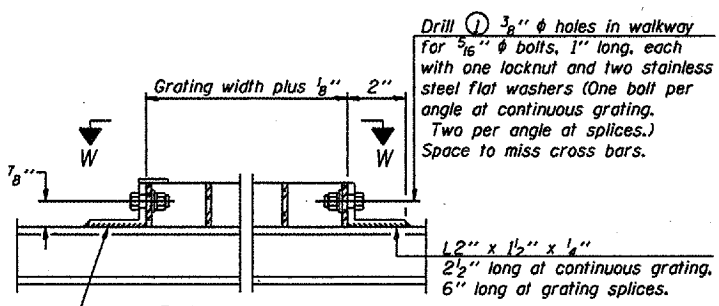
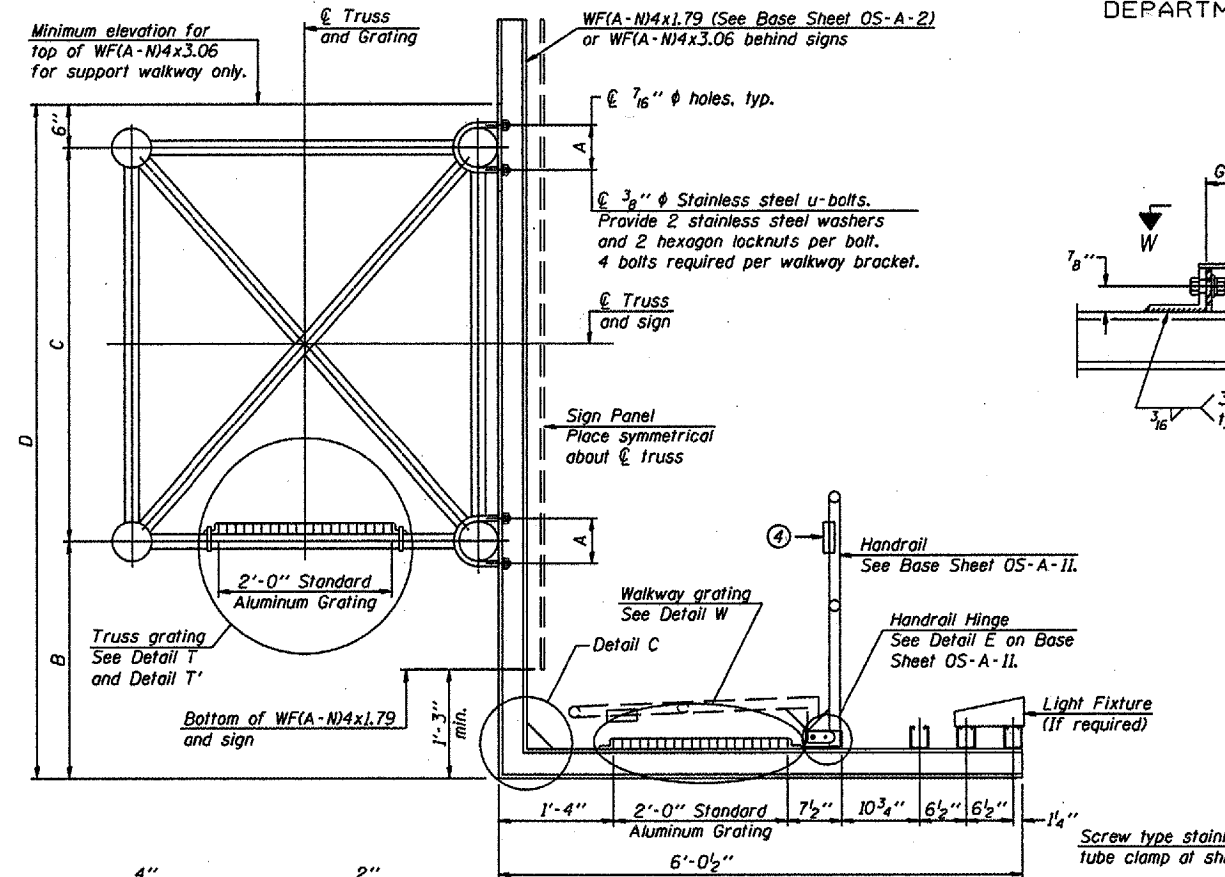

DETAIL W
(Walkway grating)

DETAIL T'

(Truss grating splice)
Details not shown same as Detail T.
Alternate materials may be used subject to the Engineer's review and approval.

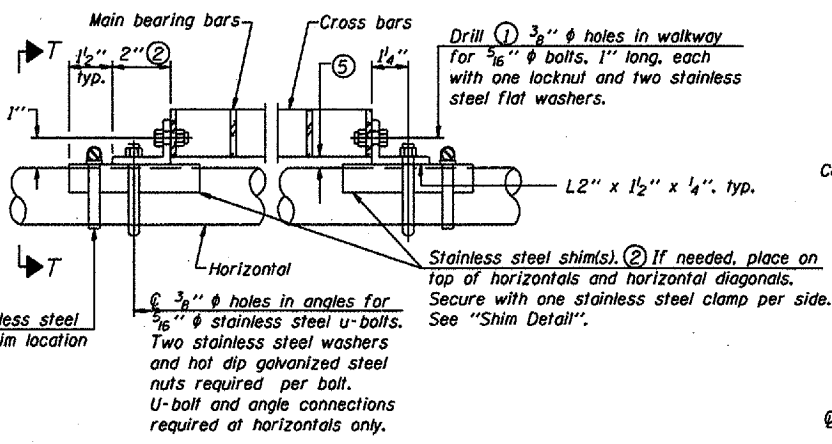

DETAIL T
(Continuous Truss grating)

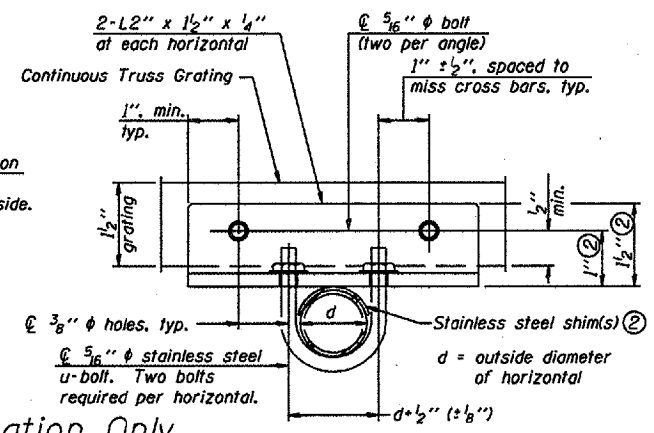

SECTION T-T

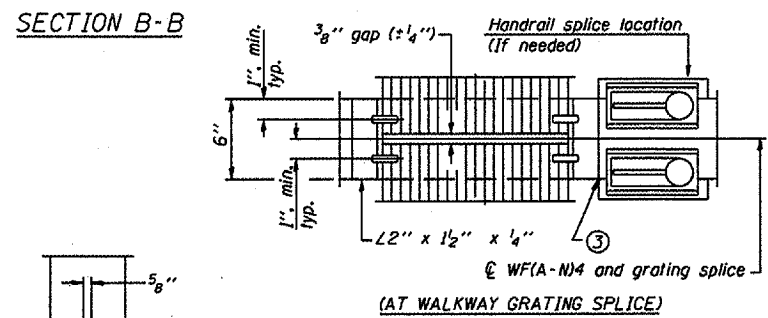
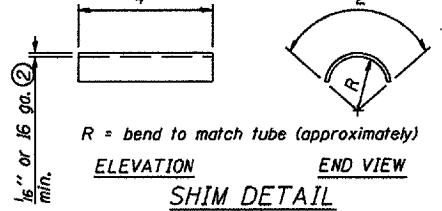

(AT WALKWAY GRATING SPLICE)

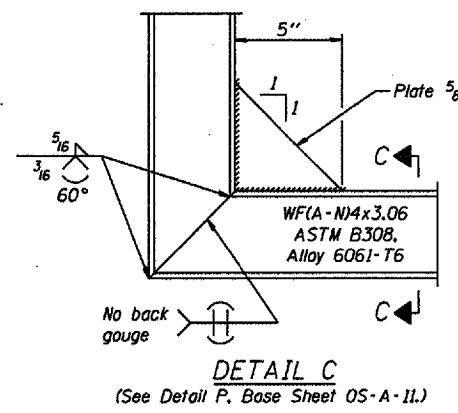
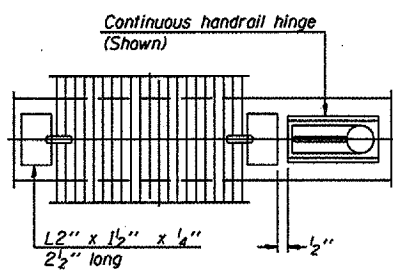

SECTION C-C

This Sheet For Information Only

SPECIFICATIONS FOR STANDARD ALUMINUM GRATING

Main Bearing Bars shall be 3/8" x 1 1/2" on 1 3/16" centers and conform to ASTM B221 Alloy 6061-T6.
Cross bars shall be 3/8" x 1 1/2" on 4" centers and conform to ASTM B221 Alloy 6063-T5 or 6061-T6.

OR

Aluminum Grating with modified "H" sections for main bearing bars shall meet the following requirements:
Main bars shall conform to ASTM B221 Alloy 6061-T6 and have a minimum section modulus equal to 0.0705 in.³ per bar, a depth of 1 1/2", spaced on 1 3/16" centers.
Cross bars shall conform to ASTM B221 Alloy 6063-T5 or T-42 and spaced on 4" centers.

Structure Number	Station	A	B	C	D

- Drilling holes in grating may be done in shop or field, based on Contractor's preference and subject to accurate alignment.
- Stainless steel shims shall be placed as shown in Detail T if needed to compensate for alignment variations between horizontal and diagonal pipes beyond adjustment provided by angles. Thicker shims may be used subject to shims performing properly.
- If Handrail Joint present, weld angle to WF(A-N)4 and 1/4" extension bars. (See Base Sheet OS-A-11.)
- 5/8" x 1/2" x 2" welded to handrail posts to protect locations that contact grating.
- Tube to grating gap may vary from 0 to 1/2", max. to align walkway, allow for camber, etc.

OVERHEAD SIGN STRUCTURES
ALUMINUM WALKWAY DETAILS

District 1
End Support Replacement

DESIGNED	20
CHECKED	EXAMINED
DRAWN	PASSED
CHECKED	ENGINEER OF BRIDGES AND STRUCTURES

NUMBER	REVISION	DATE