

STATE OF ILLINOIS  
DEPARTMENT OF TRANSPORTATION

FAP RTE. 820	SECTION (22.5)RS-3	COUNTY COLES	TOTAL SHEETS 34	SHEET NO. 1
		ILLINOIS	CONTRACT NO. 74B23	

FOR INDEX OF SHEETS, SEE SHEET NO. 2

ILL 130  
ADT: 3,400 (2021)  
DESIGN SPEED: 60 MPH  
POSTED SPEED: 55 MPH  
CRS: NB- 5.7 (2021)  
PV = 82.95% SU = 6.76% MU = 10.29%

PROPOSED  
HIGHWAY PLANS

FAP ROUTE 820 (ILL 130)  
SECTION (22.5)RS-3  
PROJECT STP-RPEQ(777)  
SMART RESURFACING  
COLES COUNTY

CHARLESTON TOWNSHIP  
SECTIONS 2, 3

SEVEN HICKORY TOWNSHIP  
SECTIONS 10, 11, 14, 15, 22, 23, 26, 27, 34, 35

C-97-088-22



STATION EQUATION  
STA 188+65.00 (BK) = STA 7+07.50 (AH)

STATION EQUATION  
STA 10+00.00 (BK) = STA 43+85.00 (AH)

PROJECT ENDS  
STA. 10 + 00.00

PROJECT BEGINS  
STA. 131 + 57.00

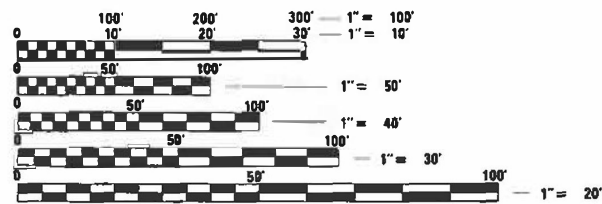

FULL SIZE PLANS HAVE BEEN PREPARED USING STANDARD ENGINEERING SCALES. REDUCED SIZED PLANS WILL NOT CONFORM TO STANDARD SCALES. IN MAKING MEASUREMENTS ON REDUCED PLANS, THE ABOVE SCALES MAY BE USED.

J.U.L.I.E.  
JOINT UTILITY LOCATION INFORMATION FOR EXCAVATORS  
1-800-892-0123  
OR 811

PROJECT ENGINEER: MATT BOWER (217)-342-8359  
PROJECT MANAGER: KEVIN WITTMAN

CONTRACT NO. 74B23

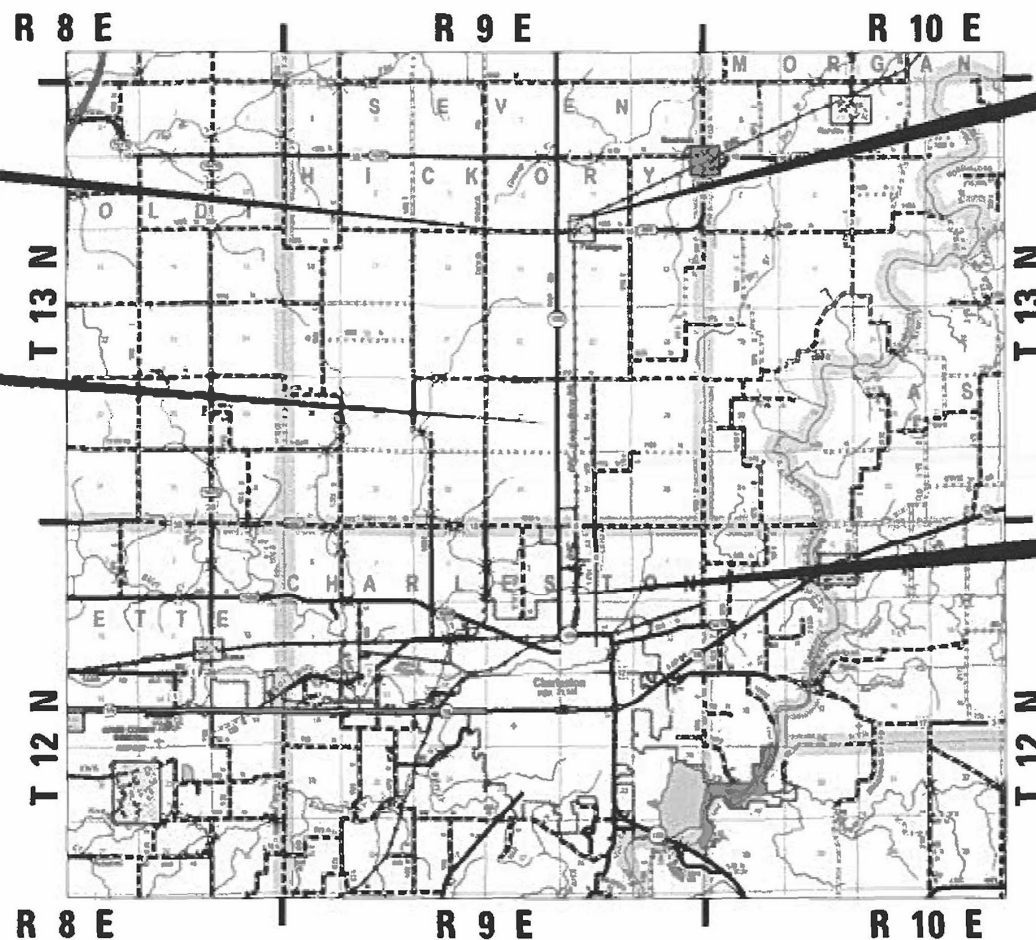

GROSS LENGTH = 26,887.00 FT. = 5.092 MILE  
NET LENGTH = 26,887.00 FT. = 5.092 MILE



Bartlett & West

1547 N. HANCOCK, SUITE 200, JEFFERSON, IL 62201  
PHONE: 618-451-1100  
ILLINOIS DESIGN PROFESSIONAL SEAL  
WWW.BARTLETTWEST.COM

STATE OF ILLINOIS  
DEPARTMENT OF TRANSPORTATION

SUBMITTED April 10, 2023  
Jeffrey P. Myrland REGIONAL ENGINEER

May 12, 2023 [Signature]  
ENGINEER OF DESIGN AND ENVIRONMENT

May 12, 2023 [Signature]  
DIRECTOR OF HIGHWAYS PROJECT IMPLEMENTATION

PRINTED BY THE AUTHORITY  
OF THE STATE OF ILLINOIS

**INDEX OF SHEETS**

1	COVER SHEET
2	INDEX OF SHEETS, LIST OF STANDARDS, GENERAL NOTES AND MIXTURE REQUIREMENTS
3-5	SUMMARY OF QUANTITIES
6	TYPICAL SECTIONS
7-10	SCHEDULE OF QUANTITIES
11-20	PLAN SHEETS
21-30	PAVEMENT MARKING SHEETS
31-33	DETAIL - PAVEMENT MARKING AND RAISED REFLECTIVE PAVEMENT MARKERS
34-34	DETAIL - PAVEMENT MARKING LETTERS AND SYMBOLS FOR TRAFFIC STAGING

**STATE STANDARDS**

000001 - 8	STANDARD SYMBOLS, ABBREVIATIONS AND PATTERNS
001006	DECIMAL OF AN INCH AND OF A FOOT
442201 - 3	CLASS C AND D PATCHES
701001 - 2	OFF-RD OPERATIONS, 2L, 2W, MORE THAN 15' (4.5 M) AWAY
701006 - 5	OFF-RD OPERATIONS, 2L, 2W, 15' (4.5 M) TO 24" (600 MM)
701011 - 4	OFF-RD MOVING OPERATIONS, 2L, 2W, DAY ONLY
701201 - 5	LANE CLOSURE, 2L, 2W, DAY ONLY, FOR SPEEDS >= 45 MPH
701301 - 4	LANE CLOSURE, 2L, 2W, SHORT TIME OPERATIONS
701306 - 4	LANE CLOSURE, 2L, 2W, SLOW MOVING OPERATIONS DAY ONLY, FOR SPEEDS >= 45 MPH
701311 - 3	LANE CLOSURE, 2L, 2W, MOVING OPERATIONS - DAY ONLY
701901 - 8	TRAFFIC CONTROL DEVICES
780001 - 5	TYPICAL PAVEMENT MARKINGS
781001 - 4	TYPICAL APPLICATIONS RAISED REFLECTIVE PAVEMENT MARKERS
701336 - 7	LANE CLOSURE, 2L, 2W, WORK AREAS IN SERIES, FOR SPEEDS >= 45 MPH
701502 - 9	URBAN LANE CLOSURE, 2L, 2W, WITH BIDIRECTIONAL LEFT TURN LANE

**THE FOLLOWING RATES OF APPLICATION HAVE BEEN USED TO CALCULATE THE PLAN QUANTITIES:**

BITUMINOUS MATERIALS (TACK COAT)	0.05 LB/SQ FT (MILLED HMA)
HOT MIX ASPHALT	112 LBS/SQ YD*IN
GRANULAR MATERIAL	2.05 TONS/CU YD

**GENERAL NOTES**

THIS SECTION SHALL BE CONSTRUCTED IN ACCORDANCE WITH THE PLANS, THE "STANDARD SPECIFICATIONS FOR ROAD AND BRIDGE CONSTRUCTION", ADOPTED JANUARY 1, 2022: THE "SUPPLEMENTAL SPECIFICATIONS AND RECURRING SPECIAL PROVISIONS" INDICATED ON THE CHECK SHEET, AND "THE SPECIAL PROVISIONS" INCLUDED IN THE PROPOSAL.

THE WORK INCLUDED IN THIS SECTION CONSISTS OF REHABILITATING APPROXIMATELY 5.1 MILES OF FAP 820 (ILL 130) BY MILLING, PATCHING, RESURFACING, AND ADDITIONAL WORK AS STATED HERE WITHIN THIS PROPOSAL.

SHORT TERM PAVEMENT MARKINGS ON THE MILLED SURFACE SHALL BE PAINT, ALL OTHER SHORT TERM MARKINGS SHALL BE TAPE.

AGGREGATE FOR AGGREGATE SHOULDERS ON PRIMARY ROUTES SHALL BE CRUSHED STONE OR RECYCLED ASPHALT PAVEMENT.

COST OF REMOVAL OF TEMPORARY RAMP SHALL BE INCLUDED IN THE UNIT PRICE FOR TEMPORARY RAMP.

THE AREA TO BE TACKED OR PRIMED SHALL BE LIMITED TO THAT WHICH CAN BE COVERED WITH HMA ON THE NEXT DAY'S PRODUCTION, BUT NO MORE THAN FIVE DAYS IN ADVANCE OF THE PLACEMENT OF THE HMA, UNLESS APPROVED BY THE ENGINEER.

THE FOLLOWING MIXTURE REQUIREMENTS ARE APPLICABLE TO THIS PROJECT:

LOCATION:	ILL 130 MAINLINE & SIDE ROADS	ILL 130 PATCHING
MIXTURE USE:	HMA SURFACE COURSE	HMA BINDER COURSE
PG:	PG 64-22	PG 64-22
DESIGN AIR VOIDS:	4.0% @ N=70	4.0% @ N=70
MIX COMPOSITION:	IL - 9.5	IL - 19.0
FRICTION AGGREGATE:	MIXTURE C	N/A
MIX WEIGHT:	112 LB/SY*IN	112 LB/SY*IN
QUALITY MANAGEMENT:	QCP	QC/QA
SUBLOT SIZE:	1000	3000
MTD:	N/A	N/A

REV. - MS

MODEL: Default  
 FILE NAME: p:\bentley\p01\Documents\Proj\20002\0822\0822\_194\OpenRoads Designer\Plan Sheets\002 - IL 130 - Index - General Notes



USER NAME =	ajc01914	DESIGNED -	REVISIONS
		DRAWN -	REVISED -
PLOT SCALE =	2500.0000' / in.	CHECKED -	REVISED -
PLOT DATE =	4/4/2023	DATE -	REVISED -

STATE OF ILLINOIS  
DEPARTMENT OF TRANSPORTATION

INDEX OF SHEETS, LIST OF STANDARDS,  
GENERAL NOTES AND MIXTURE REQUIREMENTS

SCALE: N/A SHEET 1 OF 1 SHEETS STA. N/A TO STA. N/A

F.A.P. RTE.	SECTION	COUNTY	TOTAL SHEETS	SHEET NO.
820	(22.5)RS-3	COLES	34	2
			CONTRACT NO. 74B23	
		ILLINOIS	FED. AID PROJECT	

CODE NO.	ITEM	UNIT	TOTAL QUANTITY	CONSTRUCTION CODE	
				80% FEDERAL/ 20% STATE	
				ROADWAY	ROADWAY
				0005	0005
				URBAN	RURAL
40600290	BITUMINOUS MATERIALS (TACK COAT)	POUND	37043	10853	26190
40600370	LONGITUDINAL JOINT SEALANT	FOOT	30108	10142	19966
40600990	TEMPORARY RAMP	SQ YD	72.0	28.8	43.2
40604052	HOT-MIX ASPHALT SURFACE COURSE, IL-9.5, MIX "C", N70	TON	6919	2029	4890
44000155	HOT-MIX ASPHALT SURFACE REMOVAL, 1 1/2"	SQ YD	82314	24114	58200
44201815	CLASS D PATCHES, TYPE II, 14 INCH	SQ YD	229	32	197
48102100	AGGREGATE WEDGE SHOULDER, TYPE B	TON	1524	399	1125
67000400	ENGINEER'S FIELD OFFICE, TYPE A	CAL MO	3	1	2
67100100	MOBILIZATION	L SUM	1	0.33	0.67
70100450	TRAFFIC CONTROL AND PROTECTION, STANDARD 701201	L SUM	1	0.33	0.67
70100460	TRAFFIC CONTROL AND PROTECTION, STANDARD 701306	L SUM	1	0.33	0.67
70100600	TRAFFIC CONTROL AND PROTECTION, STANDARD 701336	L SUM	1	0.33	0.67
70102622	TRAFFIC CONTROL AND PROTECTION, STANDARD 701502	L SUM	1	0.33	0.67
70107025	CHANGEABLE MESSAGE SIGN	CAL DA	28	14	14
70300100	SHORT TERM PAVEMENT MARKING	FOOT	6948	2844	4104

\* SPECIALTY ITEM

REV. - MS

MODEL: D:\mfr\ Bartlett & West\proj\2000220822\082\_194\OpenRoads Designer\Plan Sheets\003 - IL\_130\_S04  
 FILE NAME: p:\barwest\proj\2000220822\082\_194\OpenRoads Designer\Plan Sheets\003 - IL\_130\_S04



USER NAME = ajc01914	DESIGNED -	REVISED -
	DRAWN -	REVISED -
PLOT SCALE = 2500.0000' / in.	CHECKED -	REVISED -
PLOT DATE = 4/4/2023	DATE -	REVISED -

**STATE OF ILLINOIS  
DEPARTMENT OF TRANSPORTATION**

**SUMMARY OF QUANTITIES**

SCALE: N/A    SHEET 1 OF 3 SHEETS    STA. N/A TO STA. N/A

F.A.P RTE.	SECTION	COUNTY	TOTAL SHEETS	SHEET NO.
820	(22.5)RS-3	COLES	34	3
CONTRACT NO. 74B23			ILLINOIS FED. AID PROJECT	

CODE NO.	ITEM	UNIT	TOTAL QUANTITY	CONSTRUCTION CODE		
				80% FEDERAL/ 20% STATE		
				ROADWAY	ROADWAY	
				0005	0005	
				URBAN	RURAL	
	70300150	SHORT TERM PAVEMENT MARKING REMOVAL	SQ FT	1325	616	709
*	78000100	THERMOPLASTIC PAVEMENT MARKING - LETTERS AND SYMBOLS	SQ FT	219	219	
*	78000200	THERMOPLASTIC PAVEMENT MARKING - LINE 4"	FOOT	73047	28296	44751
*	78000400	THERMOPLASTIC PAVEMENT MARKING - LINE 6"	FOOT	977	977	
*	78000500	THERMOPLASTIC PAVEMENT MARKING - LINE 8"	FOOT	460	345	115
*	78000600	THERMOPLASTIC PAVEMENT MARKING - LINE 12"	FOOT	600	544	56
*	78000650	THERMOPLASTIC PAVEMENT MARKING - LINE 24"	FOOT	94	58	36
*	78011000	GROOVING FOR RECESSED PAVEMENT MARKING, LETTERS AND SYMBOLS	SQ FT	219	219	
*	78011025	GROOVING FOR RECESSED PAVEMENT MARKING 5"	FOOT	73047	28296	44751
*	78011035	GROOVING FOR RECESSED PAVEMENT MARKING 7"	FOOT	977	977	
*	78011045	GROOVING FOR RECESSED PAVEMENT MARKING 9"	FOOT	460	345	115
*	78011065	GROOVING FOR RECESSED PAVEMENT MARKING 13"	FOOT	600	544	56
*	78011125	GROOVING FOR RECESSED PAVEMENT MARKING 25"	FOOT	94	58	36
*	78100100	RAISED REFLECTIVE PAVEMENT MARKER	EACH	493	243	250

\* SPECIALTY ITEM

MODEL: D:\m...  
 FILE NAME: p:\b...  
 1207 SINGLAR DRIVE, SUITE 2 - JERSEYVILLE, IL 62052  
 PHONE 618-684-6001  
 ILLINOIS DESIGN FIRM NO. 154000050-0002  
 WWW.BARTLETTWEST.COM



USER NAME =	aj01914	DESIGNED -	REVISED -
DRAWN -		REVISIONS -	
PLOT SCALE =	2500.0000' / in.	CHECKED -	REVISED -
PLOT DATE =	4/4/2023	DATE -	REVISED -

**STATE OF ILLINOIS**  
**DEPARTMENT OF TRANSPORTATION**

SUMMARY OF QUANTITIES			
SCALE: N/A	SHEET 2	OF 3 SHEETS	STA. N/A TO STA. N/A

F.A.P RTE.	SECTION	COUNTY	TOTAL SHEETS	SHEET NO.
820	(22.5)RS-3	COLES	34	4
CONTRACT NO. 74B23				
ILLINOIS		FED. AID PROJECT		



# TYPICAL SECTION - 2 LANE 2 WAY

STA. 131+57 TO STA. 10+00  
 STA. 10+00 ( BK ) = STA. 43+85 ( AH )  
 STA. 43+85 TO STA. 188+65  
 STA. 188+65 ( BK ) = STA. 7+07.50 ( AH )

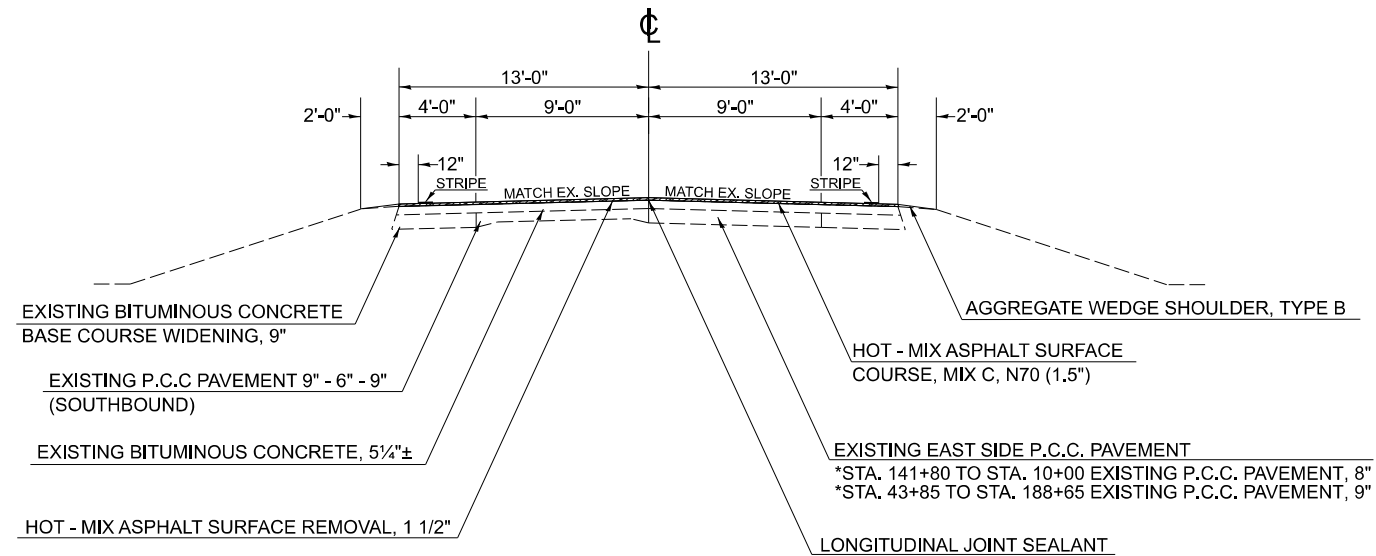

# TYPICAL SECTION - 2 LANE 2 WAY

STA. 7+07.50 TO STA. 10+00

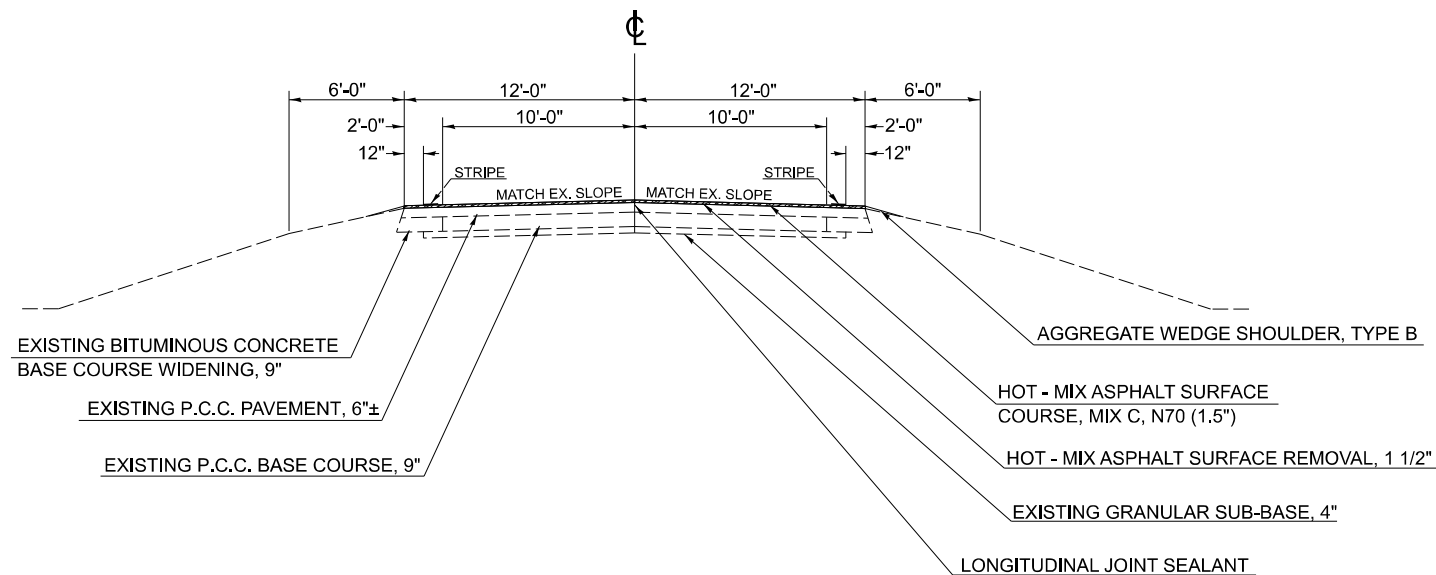

## LEGEND

- HOT - MIX ASPHALT SURFACE COURSE, MIX C, N70, ( 1.5" )
- HOT - MIX ASPHALT SURFACE REMOVAL, 1 1/2"

**Bartlett & West**

USER NAME =	aj001914
PLOT SCALE =	5.0000" / 1 in.
PLOT DATE =	4/5/2023

DESIGNED -	REVISD -
DRAWN -	REVISD -
CHECKED -	REVISD -
DATE -	REVISD -

STATE OF ILLINOIS  
 DEPARTMENT OF TRANSPORTATION

TYPICAL SECTIONS

SCALE: N/A SHEET 1 OF 1 SHEETS STA. 131+57 TO STA. 10+00

F.A.P. RTE.	SECTION	COUNTY	TOTAL SHEETS	SHEET NO.
820	(22.5)RS-3	COLES	34	6
CONTRACT NO. 74B23				
ILLINOIS FED. AID PROJECT				

MODEL: D:\infra\...  
 FILE NAME: ...  
 1207 SINCLAIR DRIVE, SUITE 2 - JERSEYVILLE, IL 62552  
 PHONE: 618-684-6001  
 ILLINOIS DESIGN FIRM NO. 154000506-0002  
 WWW.BARTLETTWEST.COM

					40600290	40600370	40600990	40604052	44000155	48102100			
PAVING SCHEDULE					LENGTH	WIDTH	PROPOSED PAVEMENT SURFACE	BITUMINOUS MATERIALS (TACK COAT)	LONGITUDINAL JOINT SEALANT	TEMPORARY RAMP	HOT-MIX ASPHALT SURFACE COURSE, IL-9.5, MIX "C", N70	HOT-MIX ASPHALT SURFACE REMOVAL, 1 1/2"	AGGREGATE WEDGE SHOULDER, TYPE B
STATION	TO	STATION	URBAN / RURAL	REMARKS	FT	FT	SQ YD	POUND	FOOT	SQ YD	TON	SQ YD	TON
131+57.00	TO	88+19.00	URBAN	MAINLINE	4338.0	26.0	12532.0	5640	4338	14.4	1053	12532	248
88+19.00	TO	84+47.00	URBAN	TAPER	372.0	26.0 TO 48.0	1529.3	689	1564		129	1530	22
84+47.00	TO	82+55.00	URBAN	MAINLINE/TURN LANE/ MEDIAN	192.0	48.0	1024.0	461	384		87	1024	11
82+55.00	TO	71+64.00	URBAN	MAINLINE/ TURN LANE	1091.0	36.0	4364.0	1964	2182		367	4364	63
71+64.00	TO	66+92.12	URBAN	TAPER	471.9	36.0 TO 26.0	1625.4	732	944		137	1626	27
66+92.12	TO	61+92.12	URBAN	MAINLINE	500.0	26.0	1444.4	650	500	14.4	122	1445	29
			URBAN	ENTRANCE RADII	1552.0		1592.8	717	230		134	1593	89
			URBAN	ENTRANCE GAPS	1568.0								-90
URBAN SJBTOTAL								10853	10142	28.8	2029	24114	399
61+92.12	TO	10+00.00	RURAL	MAINLINE	5192.1	26.0	14999.5	6750	5193	14.4	1260	15000	296
<b>10+00 BK = 43+85 AH</b>													
43+85.00	TO	188+65.00	RURAL	MAINLINE	14480.0	26.0	41831.1	18824	14480	14.4	3514	41832	825
<b>188+65 BK = 7+07.50 AH</b>													
7+07.50	TO	10+00.00	RURAL	MAINLINE	292.5	24.0	780.0	351	293	14.4	66	780	17
			RURAL	ENTRANCE RADII	1505.0		587.8	265			50	588	86
			RURAL	ENTRANCE GAPS	1723.0								-99
RURAL SJBTOTAL								26190	19966	43.2	4890	58200	1125
<b>TOTAL</b>								<b>37043</b>	<b>30108</b>	<b>72.0</b>	<b>6919</b>	<b>82314</b>	<b>1524</b>

MODEL: D:\inf\...  
 FILE NAME: ...  
 1207 SINCLAIR DRIVE, SUITE 2 - JERSEYVILLE, IL 62552  
 PHONE: 618-684-6991  
 ILLINOIS DESIGN FIRM NO. 154000356-0002  
 WWW.BARTLETTWEST.COM



USER NAME =	aj01914	DESIGNED -	REVISED -
		DRAWN -	REVISED -
PLOT SCALE =	2500.0000' / in.	CHECKED -	REVISED -
PLOT DATE =	4/4/2023	DATE -	REVISED -

**STATE OF ILLINOIS**  
**DEPARTMENT OF TRANSPORTATION**

**SCHEDULE OF QUANTITIES**

SCALE: N/A    SHEET 1 OF 4 SHEETS    STA. N/A    TO STA. N/A

F.A.P. RTE.	SECTION	COUNTY	TOTAL SHEETS	SHEET NO.
820	(22.5)RS-3	COLES	34	7
CONTRACT NO. 74B23				
		ILLINOIS	FED. AID PROJECT	

						70300100	70300150	78000100	78000200	78000400	78000500	78000600	78000650
PAVEMENT MARKING SCHEDULE						SHORT TERM PAVEMENT MARKING	SHORT TERM PAVEMENT MARKING REMOVAL	THERMOPLASTIC PAVEMENT MARKING - LETTERS AND SYMBOLS	THERMOPLASTIC PAVEMENT MARKING - LINE 4"	THERMOPLASTIC PAVEMENT MARKING - LINE 6"	THERMOPLASTIC PAVEMENT MARKING - LINE 8"	THERMOPLASTIC PAVEMENT MARKING - LINE 12"	THERMOPLASTIC PAVEMENT MARKING - LINE 24"
STATION	TO	STATION	NO PASSING ZONE	URBAN / RURAL	REMARKS	FOOT	SQ FT	SQ FT	FOOT	FOOT	FOOT	FOOT	FOOT
131+57.00	TO	61+92.12		URBAN	NB & SB EOP				13930				
131+57.00	TO	86+31.51	NB & SB	URBAN	CENTERLINE	912	152		9051				
87+94.29	TO	83+44.56		URBAN	RT TURN LANE - NB	216	68	63		286			
86+31.51	TO	83+27.59		URBAN	PAINTED MEDIAN	288	48		1436			113	
82+52.31	TO	76+63.88		URBAN	PAINTED MEDIAN	352	59		1760			90	
81+66.00	TO	76+63.88		URBAN	LT TURN LANE - NB	256	76	78		346			
76+45.00	TO	76+12.44		URBAN	PAINT ISLAND - SB						193	69	
76+45.00	TO	75+49.61		URBAN	STOP BARS - 2 SB/ 2 NB	116	58						58
76+45.00	TO	75+49.61		URBAN	CENTERLINE - 1000 N	48	8		60				
75+93.01	TO	75+49.61		URBAN	PAINT ISLAND - NB						152	104	
75+46.34	TO	70+27.92		URBAN	LT TURN LANE - SB	256	80	78		345			
75+46.34	TO	66+92.12		URBAN	PAINTED MEDIAN	296	50		1450			168	
66+92.12	TO	61+92.12	SB	URBAN	CENTERLINE	104	18		625				
				URBAN	ENTRANCE RADII				1552				
				URBAN	ENTRANCE GAPS				-1568				
<b>SUBTOTAL</b>						<b>2844</b>	<b>616</b>	<b>219</b>	<b>28296</b>	<b>977</b>	<b>345</b>	<b>544</b>	<b>58</b>
61+92.12	TO	10+00.00		RURAL	NB & SB EOP				10385				
61+92.12	TO	10+00.00		RURAL	CFNTFRI INF	1040	174		1299				
<b>10+00 BK = 43+85 AH</b>													
43+85.00	TO	188+65.00		RURAL	NB & SB EOP				28960				
43+85.00	TO	188+65.00		RURAL	CENTERLINE	2896	483		3620				
<b>188+65 BK = 7+07.50 AH</b>													
7+07.50	TO	10+00.00		RURAL	NB & SB EOP				585				
7+07.50	TO	10+00.00		RURAL	CENTERLINE	64	11		80				
8+53.29	TO	9+02.68		RURAL	STOP BARS - 2 NB/ 1 SB	72	36						36
8+53.29	TO	9+02.68		RURAL	CENTERLINE - 1400 N	32	6		40				
8+68.83	TO	9+02.68		RURAL	PAINT ISLAND - NB						115	56	
				RURAL	ENTRANCE RADII				1505				
				RURAL	ENTRANCE GAPS				-1723				
<b>SUBTOTAL</b>						<b>4104</b>	<b>709</b>		<b>44751</b>		<b>115</b>	<b>56</b>	<b>36</b>
<b>TOTAL</b>						<b>6948</b>	<b>1325</b>	<b>219</b>	<b>73047</b>	<b>977</b>	<b>460</b>	<b>600</b>	<b>94</b>

MODEL: D:\mfr\...  
 FILE NAME: ...  
 1207 SINGLAR DRIVE, SUITE 2 - JERSEYVILLE, IL 62502  
 PHONE: 618-684-6001  
 ILLINOIS DESIGN FIRM NO. 154000550-0002  
 WWW.BARTLETTWEST.COM



USER NAME =	aj01914	DESIGNED -	REVISED -
DRAWN -		REVISOR -	
PLOT SCALE =	2500.0000' / in.	CHECKED -	REVISED -
PLOT DATE =	4/4/2023	DATE -	REVISED -

**STATE OF ILLINOIS  
DEPARTMENT OF TRANSPORTATION**

<b>SCHEDULE OF QUANTITIES</b>			
SCALE: N/A	SHEET 2	OF 4 SHEETS	STA. N/A TO STA. N/A

F.A.P. RTE.	SECTION	COUNTY	TOTAL SHEETS	SHEET NO.
820	(22.5)RS-3	COLES	34	8
CONTRACT NO. 74B23				
		ILLINOIS	FED. AID PROJECT	



PAVEMENT MARKING SCHEDULE - CONTINUED						78011000	78011025	78011035	78011045	78011065	78011125	78100100	78300200
						GROOVING FOR RECESSED PAVEMENT MARKING, LETTERS AND SYMBOLS	GROOVING FOR RECESSED PAVEMENT MARKING 5"	GROOVING FOR RECESSED PAVEMENT MARKING 7"	GROOVING FOR RECESSED PAVEMENT MARKING 9"	GROOVING FOR RECESSED PAVEMENT MARKING 13"	GROOVING FOR RECESSED PAVEMENT MARKING 25"	RAISED REFLECTIVE PAVEMENT MARKER	RAISED REFLECTIVE PAVEMENT MARKER REMOVAL
STATION	TO	STATION	NO PASSING ZONE	URBAN / RURAL	REMARKS	SQ FT	FOOT	FOOT	FOOT	FOOT	FOOT	EACH	EACH
131+57.00	TO	61+92.12		URBAN	NB & SB EOP		13930						
131+57.00	TO	86+31.51	NB & SB	URBAN	CENTERLINE		9051					114	114
87+94.29	TO	83+44.56		URBAN	RT TURN LANE - NB	63		286				12	12
86+31.51	TO	83+27.59		URBAN	PAINTED MEDIAN		1436			113		38	38
82+52.31	TO	76+63.88		URBAN	PAINTED MEDIAN		1760			90		46	46
81+66.00	TO	76+63.88		URBAN	LT TURN LANE - NB	78		346				13	13
76+45.00	TO	76+12.44		URBAN	PAINT ISLAND - SB				193	69			
76+45.00	TO	75+49.61		URBAN	STOP BARS - 2 SB/ 2 NB						58		
76+45.00	TO	75+49.61		URBAN	CENTERLINE - 1000 N		60						
75+93.01	TO	75+49.61		URBAN	PAINT ISLAND - NB				152	104			
75+46.34	TO	70+27.92		URBAN	LT TURN LANE - SB	78		345				13	13
75+46.34	TO	66+92.12		URBAN	PAINTED MEDIAN		1450			168			
66+92.12	TO	61+92.12	SB	URBAN	CENTERLINE		625					7	7
				URBAN	ENTRANCE RADII		1552						
				URBAN	ENTRANCE GAPS		-1568						
<b>SUBTOTAL</b>						<b>219</b>	<b>28296</b>	<b>977</b>	<b>345</b>	<b>544</b>	<b>58</b>	<b>243</b>	<b>243</b>
61+92.12	TO	10+00.00		RURAL	NB & SB EOP		10385						
61+92.12	TO	10+00.00		RURAL	CFNTFRI INF		1299					65	65
<b>10+00 BK = 43+85 AH</b>													
43+85.00	TO	188+65.00		RURAL	NB & SB EOP		28960						
43+85.00	TO	188+65.00		RURAL	CENTERLINE		3620					181	181
<b>188+65 BK = 7+07.50 AH</b>													
7+07.50	TO	10+00.00		RURAL	NB & SB EOP		585						
7+07.50	TO	10+00.00		RURAL	CENTERLINE		80					4	4
8+53.29	TO	9+02.68		RURAL	STOP BARS - 2 NB/ 1 SB						36		
8+53.29	TO	9+02.68		RURAL	CENTERLINE - 1400 N		40						
8+68.83	TO	9+02.68		RURAL	PAINT ISLAND - NB				115	56			
				RURAL	ENTRANCE RADII		1505						
				RURAL	ENTRANCE GAPS		-1723						
<b>SUBTOTAL</b>							<b>44751</b>		<b>115</b>	<b>56</b>	<b>36</b>	<b>250</b>	<b>250</b>
<b>TOTAL</b>						<b>219</b>	<b>73047</b>	<b>977</b>	<b>460</b>	<b>600</b>	<b>94</b>	<b>493</b>	<b>493</b>

MODEL: D:\mfr\... Bartlett & West\paw\hwy.com\bartwest-paw-01\Documents\Proj\2000020082\2082\_184\OpenRoads\Design\FPlan\_Sheets\005 - IL\_130\_Schedule of Quantities



USER NAME =	aj01914	DESIGNED -	REVISED -
DRAWN -		REVISOR -	
PLOT SCALE =	2500.0000"/in.	CHECKED -	REVISED -
PLOT DATE =	4/4/2023	DATE -	REVISED -

**STATE OF ILLINOIS  
DEPARTMENT OF TRANSPORTATION**

<b>SCHEDULE OF QUANTITIES</b>			
SCALE: N/A	SHEET 3	OF 4 SHEETS	STA. N/A TO STA. N/A

F.A.P. RTE.	SECTION	COUNTY	TOTAL SHEETS	SHEET NO.
820	(22.5)RS-3	COLES	34	9
CONTRACT NO. 74B23				
ILLINOIS FED. AID PROJECT				

PATCHING SCHEDULE - NB - URBAN

44201815

LOCATION		LENGTH FT	WIDTH FT	CLASS D PATCHES, TYPE II, 14 INCH SQ YD
STATION	REMARKS			
116+73	NB URBAN	4.0	12.0	5.3
115+92	NB URBAN	4.0	12.0	5.3
112+34	NB URBAN	4.0	12.0	5.3
98+49	NB URBAN	4.0	12.0	5.3
<b>NB - URBAN SUBTOTAL</b>				<b>21.2</b>

PATCHING SCHEDULE - SB - URBAN

44201815

LOCATION		LENGTH FT	WIDTH FT	CLASS D PATCHES, TYPE II, 14 INCH SQ YD
STATION	REMARKS			
113+79	SB URBAN	4.0	12.0	5.3
89+26	SB URBAN	4.0	12.0	5.3
<b>SB - URBAN SUBTOTAL</b>				<b>10.6</b>

PATCHING SCHEDULE - SB - RURAL

44201815

LOCATION		LENGTH FT	WIDTH FT	CLASS D PATCHES, TYPE II, 14 INCH SQ YD
STATION	REMARKS			
48+75	SB RURAL	4.0	12.0	5.3
41+21	SB RURAL	4.0	12.0	5.3
18+92	SB RURAL	4.0	12.0	5.3
<b>10+00 BK = 43+85 AH</b>				
103+50	SB RURAL	4.0	12.0	5.3
112+59	SB RURAL	4.0	12.0	5.3
128+76	SB RURAL	4.0	12.0	5.3
148+52	SB RURAL	4.0	12.0	5.3
157+86	SB RURAL	4.0	12.0	5.3
163+23	SB RURAL	4.0	12.0	5.3
165+23	SB RURAL	4.0	12.0	5.3
172+30	SB RURAL	4.0	12.0	5.3
188+30	SB RURAL	4.0	12.0	5.3
<b>SB - RURAL SUBTOTAL</b>				<b>63.6</b>

PATCHING SCHEDULE - NB - RURAL

44201815

LOCATION		LENGTH FT	WIDTH FT	CLASS D PATCHES, TYPE II, 14 INCH SQ YD
STATION	REMARKS			
36+42	NB RURAL	6.0	12.0	8.0
26+36	NB RURAL	6.0	12.0	8.0
<b>10+00 BK = 43+85 AH</b>				
50+73	NB RURAL	6.0	12.0	8.0
57+92	NB RURAL	6.0	12.0	8.0
77+58	NB RURAL	6.0	12.0	8.0
85+00	NB RURAL	6.0	12.0	8.0
88+93	NB RURAL	4.0	12.0	5.3
90+47	NB RURAL	4.0	12.0	5.3
91+83	NB RURAL	4.0	12.0	5.3
93+24	NB RURAL	4.0	12.0	5.3
95+23	NB RURAL	4.0	12.0	5.3
98+21	NB RURAL	4.0	12.0	5.3
119+12	NB RURAL	4.0	12.0	5.3
121+37	NB RURAL	4.0	12.0	5.3
128+79	NB RURAL	4.0	12.0	5.3
139+18	NB RURAL	4.0	12.0	5.3
140+64	NB RURAL	4.0	12.0	5.3
154+21	NB RURAL	4.0	12.0	5.3
164+82	NB RURAL	4.0	12.0	5.3
173+74	NB RURAL	4.0	12.0	5.3
188+30	NB RURAL	4.0	12.0	5.3
189+68	NB RURAL	4.0	12.0	5.3
<b>NB - RURAL SUBTOTAL</b>				<b>132.8</b>

MODEL: D:\mfd\...  
 FILE NAME: ...  
 1207 SINGLAR DRIVE, SUITE 2 - JERSEYVILLE, IL 62552  
 PHONE: 618-684-6991  
 ILLINOIS DESIGN FIRM NO. 154000550-0002  
 WWW.BARTLETTWEST.COM



USER NAME =	aj01914	DESIGNED -	REVISED -
		DRAWN -	REVISED -
PLOT SCALE =	2500.0000' / in.	CHECKED -	REVISED -
PLOT DATE =	4/4/2023	DATE -	REVISED -

**STATE OF ILLINOIS**  
**DEPARTMENT OF TRANSPORTATION**

**SCHEDULE OF QUANTITIES**

SCALE: N/A    SHEET 4 OF 4 SHEETS    STA. N/A    TO STA. N/A

F.A.P. RTE.	SECTION	COUNTY	TOTAL SHEETS	SHEET NO.
820	(22.5)RS-3	COLES	34	10
CONTRACT NO. 74B23				
ILLINOIS FED. AID PROJECT				

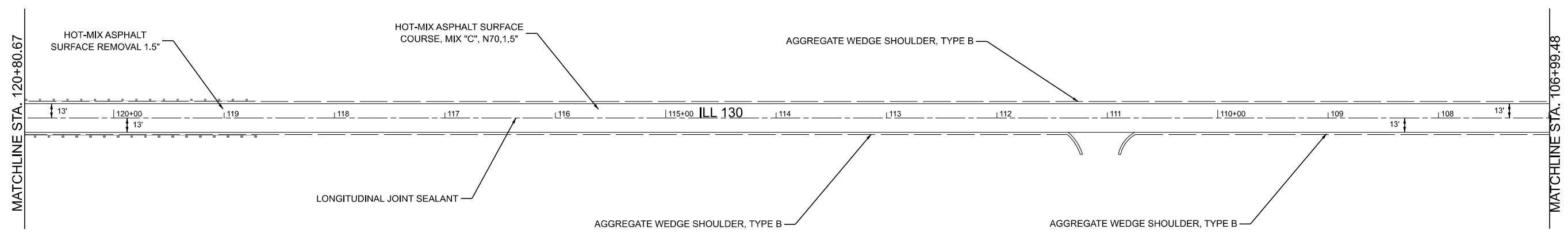
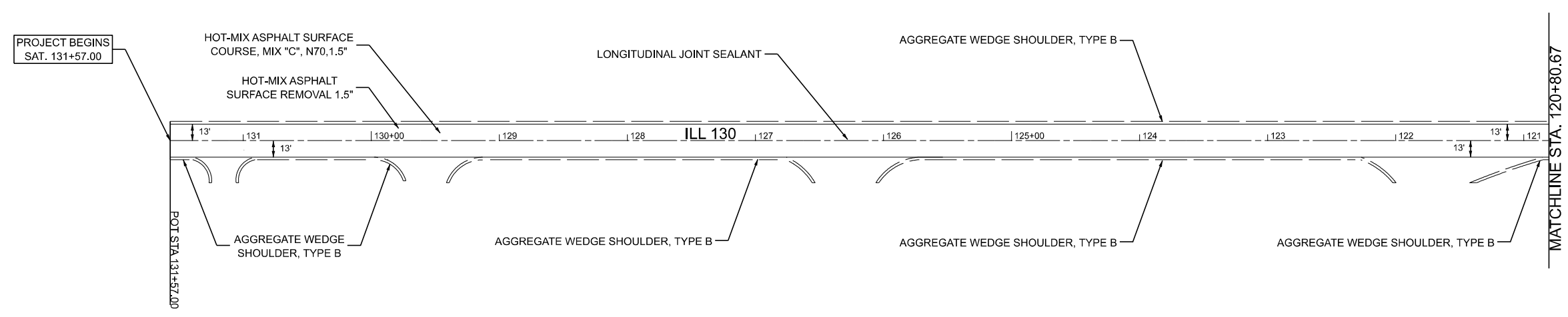

MODEL ILL 130-A1 - Plan 1 [Sheet]  
 FILE NAME: P:\Roadway\Projects\130\130-A1\Drawings\Plan\130-A1-130-Roadway-Plan-Sheets

**Bartlett & West**  
 1207 SINCLAIR DRIVE, SUITE 2 - JERSEYVILLE, IL 62052  
 PHONE: 618-894-6501  
 ILLINOIS DESIGN FIRM NO. 154000516-0002  
 WWW.BARTLETTWEST.COM

USER NAME =	ajc01914	DESIGNED -	REVISED -
DRAWN -		REVISIONS -	
PLOT SCALE =	49,999990000' / in.	CHECKED -	REVISED -
PLOT DATE =	4/4/2023	DATE -	REVISED -

**STATE OF ILLINOIS**  
**DEPARTMENT OF TRANSPORTATION**

**ROADWAY PLANS**

SCALE: 50    SHEET 1    OF 10 SHEETS    STA. 131+57.00    TO STA. 106+99.48

F.A.P. RTE.	SECTION	COUNTY	TOTAL SHEETS	SHEET NO.
820	(22,5)RS-3	COLES	34	11
CONTRACT NO. 74B23				
ILLINOIS FED. AID PROJECT				

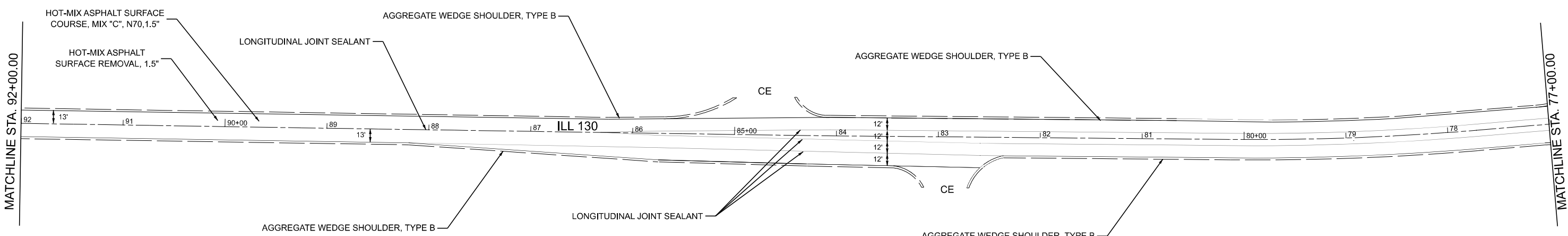
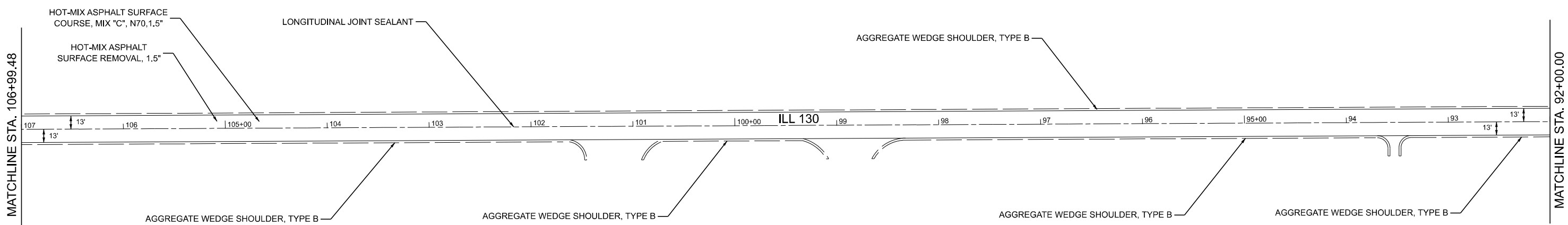

MODEL: ILL 130-A1 - Plan 3 (Sheet)  
 FILE NAME: p:\databases\pc\mfr\2020022008220822\104\OpenRoads\Designer\Plan Sheets\006 - ILL 130\_Roadway\_Plan\_Sheets

**Bartlett & West**  
 1207 SINGULAR DRIVE, SUITE 2 - JERSEYVILLE, IL 62052  
 PHONE: 618-664-6001  
 ILLINOIS DESIGN FIRM NO. 12-0000056-0002  
 WWW.BARTLETTWEST.COM

USER NAME =	ajc01914	DESIGNED -	REVISED -
		DRAWN -	REVISED -
PLOT SCALE =	49.99990000' / in.	CHECKED -	REVISED -
PLOT DATE =	4/4/2023	DATE -	REVISED -

**STATE OF ILLINOIS  
DEPARTMENT OF TRANSPORTATION**

**ROADWAY PLANS**

SCALE: 50      SHEET 2 OF 10 SHEETS      STA. 107+00.00 TO STA. 77+00.00

F.A.P. RTE.	SECTION	COUNTY	TOTAL SHEETS	SHEET NO.
820	(22,5)RS-3	COLES	34	12
CONTRACT NO. 74B23			ILLINOIS FED. AID PROJECT	

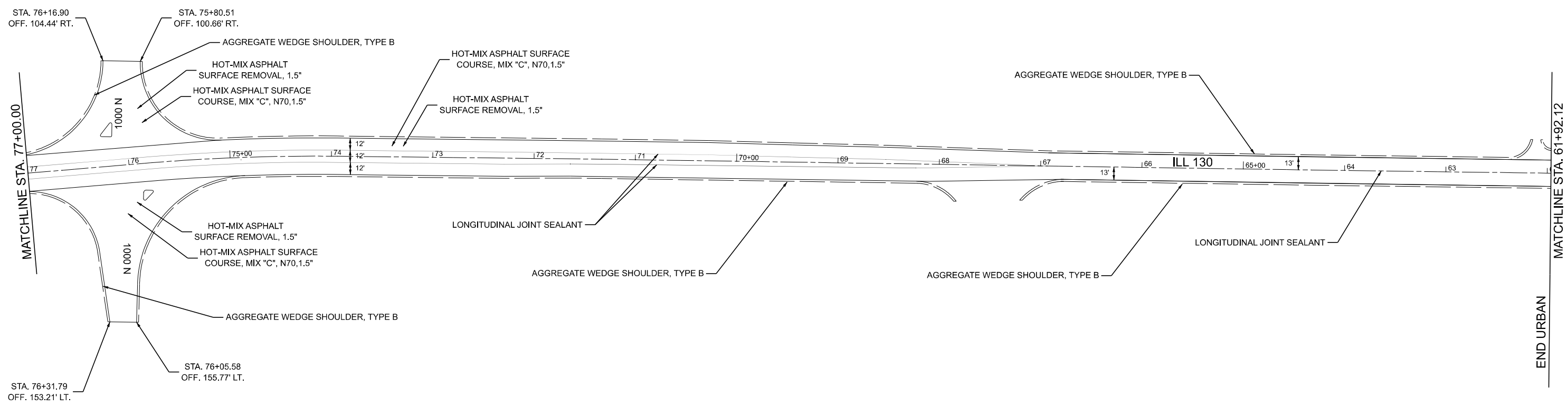
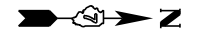

MATCHLINE STA. 61+92.12  
END URBAN

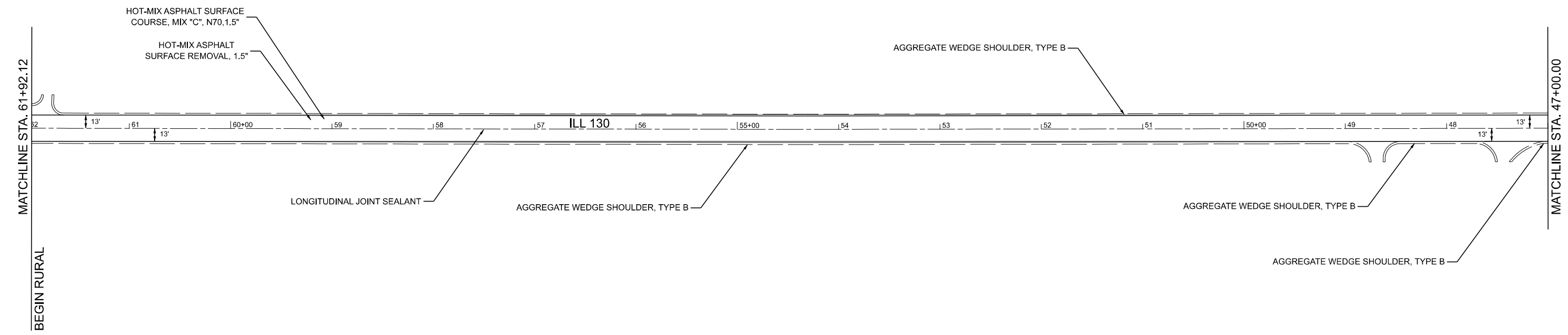
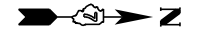

MATCHLINE STA. 61+92.12  
BEGIN RURAL

MATCHLINE STA. 47+00.00

MODEL: ILL 130-A1 - Plan 3 (Sheet)  
FILE NAME: p:\z\barrett\p\c\central\com\barrett\west\pa-4\1\Documents\Plan\2000020082\2082\_194\OpenRoads Designer\Plan Sheets\ILL 130\_Roadway\_Plan\_Sheets

**Bartlett & West**  
1207 SINGLAR DRIVE, SUITE 2 - JERSEYVILLE, IL 62052  
PHONE: 618-664-6091  
ILLINOIS DESIGN FIRM NO. 194000550-0002  
WWW.BARTLETTWEST.COM

USER NAME =	aj01914	DESIGNED -		REVISED -	
		DRAWN -		REVISED -	
PLOT SCALE =	49.99990000' / in.	CHECKED -		REVISED -	
PLOT DATE =	4/4/2023	DATE -		REVISED -	

**STATE OF ILLINOIS  
DEPARTMENT OF TRANSPORTATION**

**ROADWAY PLANS**

SCALE: 50    SHEET 3 OF 10 SHEETS    STA. 77+00.00 TO STA. 47+00.00

F.A.P. RTE.	SECTION	COUNTY	TOTAL SHEETS	SHEET NO.
820	(22.5)RS-3	COLES	34	13
CONTRACT NO. 74B23				
ILLINOIS FED. AID PROJECT				

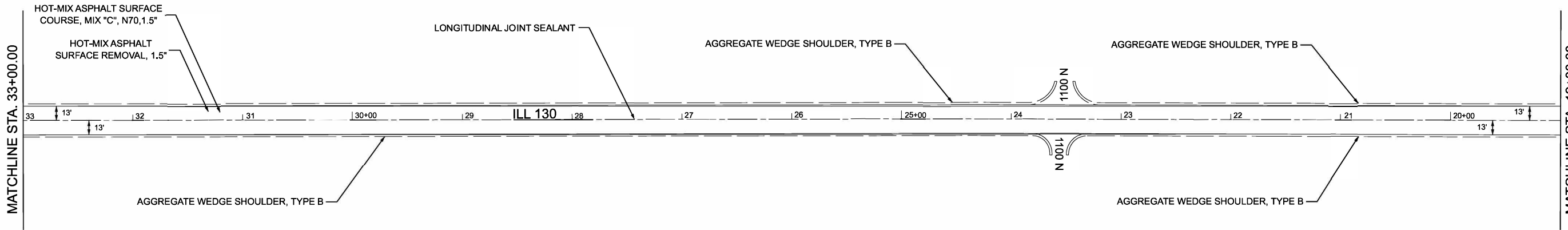
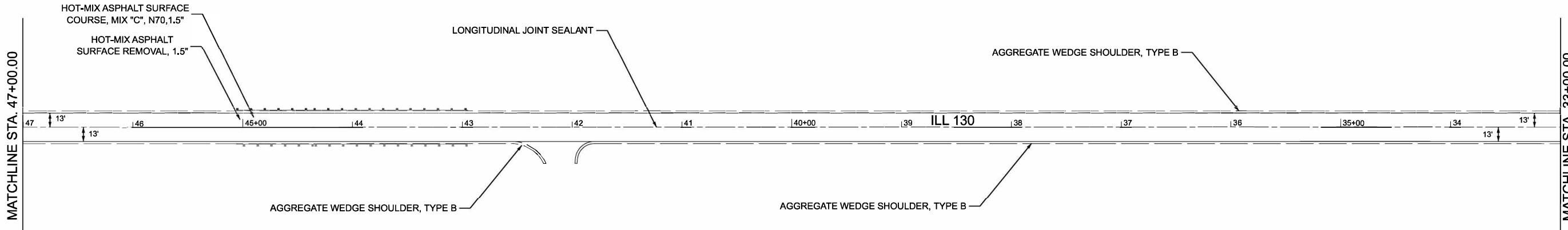

REV. - MS

MODEL: ILL 130 - A1 - Plan 9 (Sheet)  
 FILE NAME: p:\2023\Illinois\Projects\194\OpenRoads\Design\Plan Sheets\006 - ILL 130\_Roadway Plan Sheets



USER NAME =	ajcd1914	DESIGNED -	REVISED -
		DRAWN -	REVISED -
PLOT SCALE =	49.99990000 1/in.	CHECKED -	REVISED -
PLOT DATE =	4/4/2023	DATE -	REVISED -

**STATE OF ILLINOIS**  
**DEPARTMENT OF TRANSPORTATION**

**ROADWAY PLANS**

SCALE: 50      SHEET 4      OF 10 SHEETS      STA. 47+00.00      TO STA. 19+00.00

F.A.P. RTE.	SECTION	COUNTY	TOTAL SHEETS	SHEET NO.
820	(22,5)RS-3	COLES	34	14
CONTRACT NO. 74B23				
		ILLINOIS	FED. AID PROJECT	



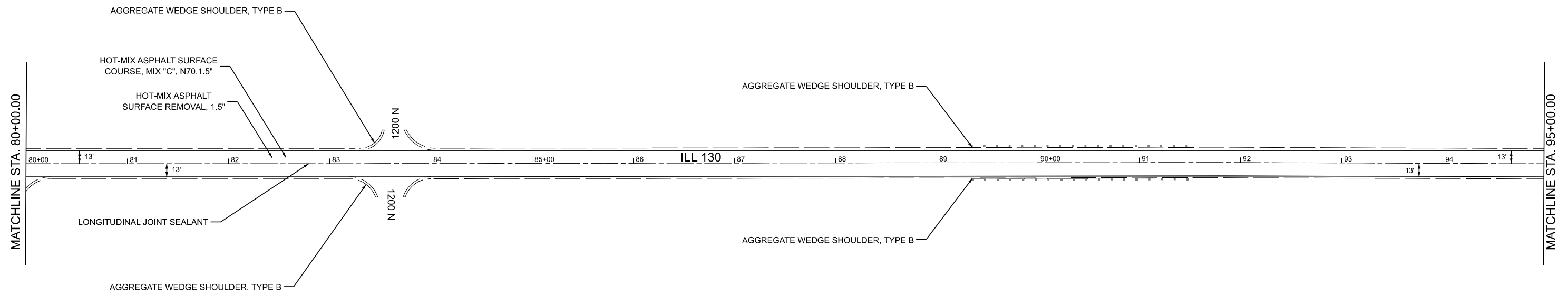
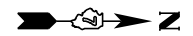
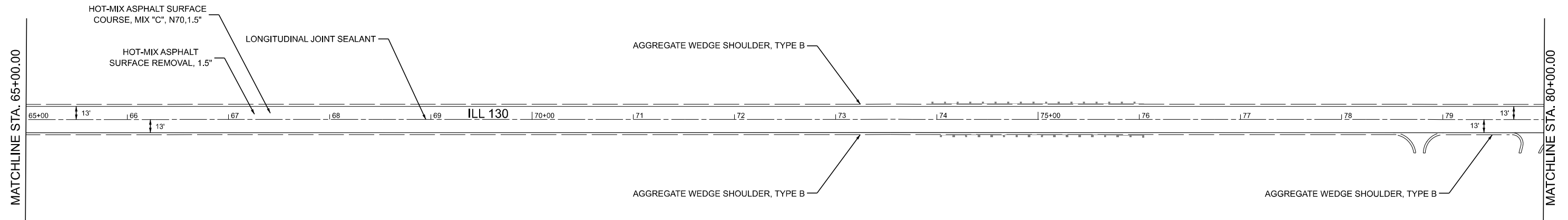

MODEL: ILL 130 - A1 - Plan 14 (Sheet)  
 FILE NAME: P:\Bartlett\Projects\2020\20200822\0822\_194\OpenRoads\Design\Plan\_Sheets\006 - ILL 130\_Roadway\_Plan\_Sheets

**Bartlett & West**  
 1207 SINCLAIR DRIVE, SUITE 2 - JERSEYVILLE, IL 62052  
 PHONE: 618-634-6001  
 ILLINOIS DESIGN FIRM NO. 15-000599-0002  
 WWW.BARTLETTWEST.COM

USER NAME =	ajc01914	DESIGNED -	REVISED -
PLOT SCALE =	49.999990000 ' / in.	DRAWN -	REVISED -
PLOT DATE =	4/4/2023	CHECKED -	REVISED -
		DATE -	REVISED -

STATE OF ILLINOIS  
 DEPARTMENT OF TRANSPORTATION

ROADWAY PLANS

SCALE: 50 SHEET 6 OF 10 SHEETS STA. 65+00.00 TO STA. 95+00.00

F.A.P. RTE.	SECTION	COUNTY	TOTAL SHEETS	SHEET NO.
820	(22.5)RS-3	COLES	34	16
CONTRACT NO. 74B23				
ILLINOIS FED. AID PROJECT				



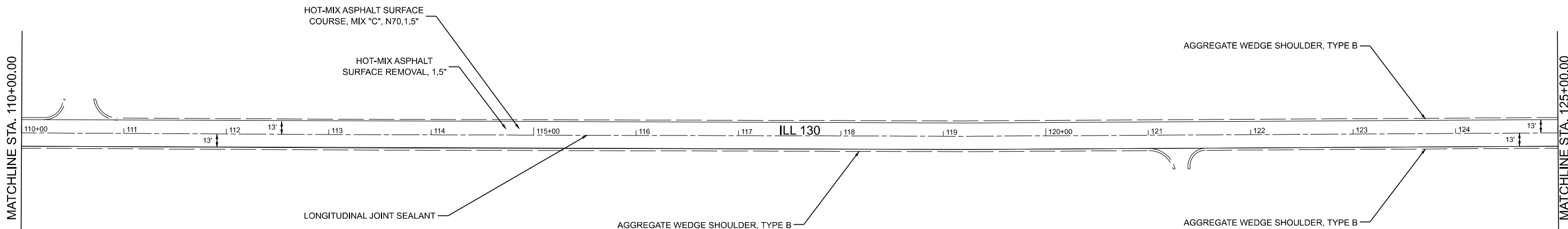
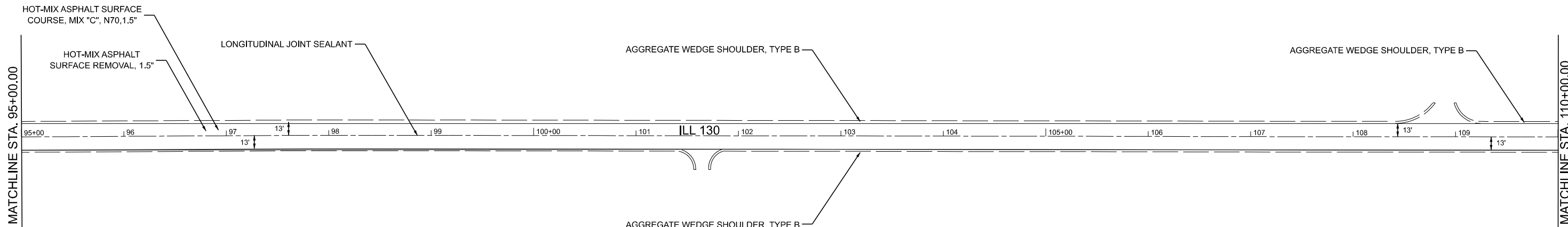

MODEL: ILL 130-A1 - Plan 16 [Sheet]  
 FILE NAME: p:\data\west\paw\c01\Documents\Plan\920002\2002\2002\194\OpenRoads\Designer\Plan Sheets\005 - ILL 130\_Roadway Plan Sheets

**Bartlett & West**  
 1207 SINGULAR DRIVE, SUITE 2 - JERSEYVILLE, IL 62052  
 PHONE: 618-894-6001  
 ILLINOIS DESIGN FIRM NO. 124600456-0002  
 WWW.BARTLETTWEST.COM

USER NAME =	ajc01914	DESIGNED -	REVISED -
		DRAWN -	REVISED -
PLOT SCALE =	49.999990000' / in.	CHECKED -	REVISED -
PLOT DATE =	4/4/2023	DATE -	REVISED -

**STATE OF ILLINOIS  
 DEPARTMENT OF TRANSPORTATION**

**ROADWAY PLANS**

SCALE: 50 SHEET 7 OF 10 SHEETS STA. 95+00.00 TO STA. 125+00.00

F.A.P. RTE.	SECTION	COUNTY	TOTAL SHEETS	SHEET NO.
820	(22.5)RS-3	COLES	34	17
CONTRACT NO. 74B23			ILLINOIS FED. AID PROJECT	

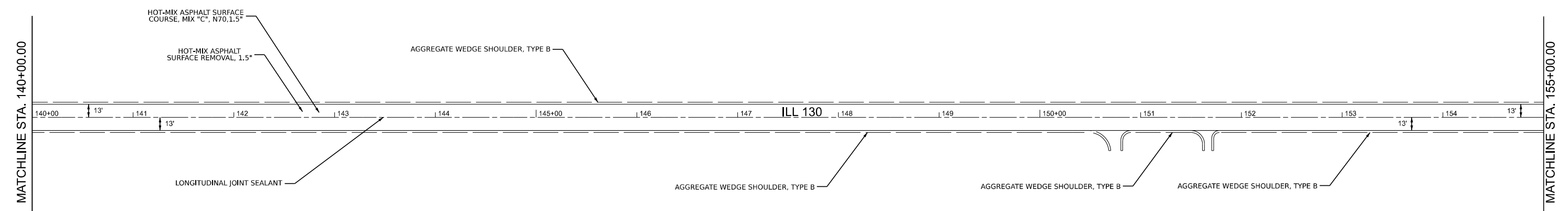
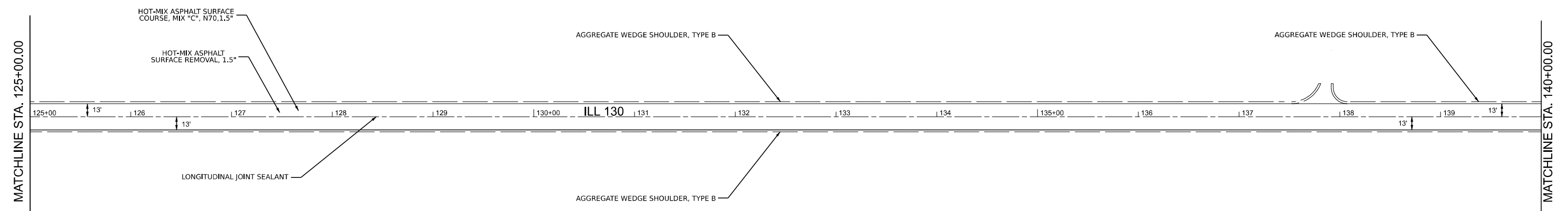

MODEL ILL 130-A1 - Plan 18 [Sheet]  
 FILE NAME: p:\datawest\pcc\central\com\bartwest\pcc\01\Documents\Plan\2020\2020\2082\2082\_130\_Roadway\_Plan\_Sheets  
 1207 SINCLAIR DRIVE, SUITE 2 - JERSEYVILLE, IL 62052  
 PHONE: 618-994-6001  
 ILLINOIS DESIGN FIRM NO. 124600658-0002  
 WWW.BARTLETTWEST.COM



USER NAME =	ajc01914	DESIGNED -	REVISED -
		DRAWN -	REVISED -
PLOT SCALE =	49.999990000' / in.	CHECKED -	REVISED -
PLOT DATE =	4/1/2023	DATE -	REVISED -

**STATE OF ILLINOIS  
DEPARTMENT OF TRANSPORTATION**

**ROADWAY PLANS**

SCALE: 50 SHEET 8 OF 10 SHEETS STA. 125+00.00 TO STA. 155+00.00

F.A.P. RTE.	SECTION	COUNTY	TOTAL SHEETS	SHEET NO.
820	(22.5)RS-3	COLES	34	18
CONTRACT NO. 74B23			ILLINOIS FED. AID PROJECT	

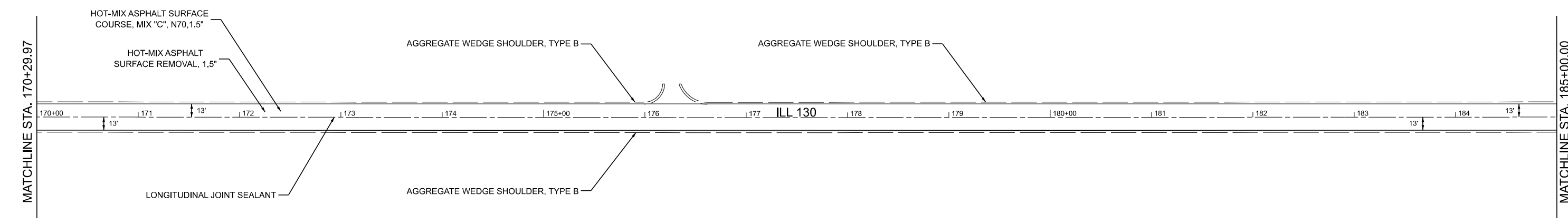
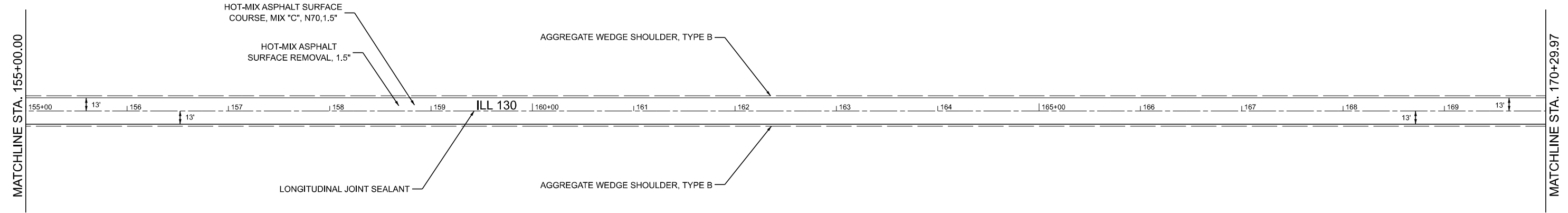

MODEL: ILL\_130 - A1 - Plan 20 (Sheet)  
 FILE NAME: \\barlettwest\prodent\p\2000\2008\200822\0822\1st\OpenRoads\Drawings\Plan\_Sheets\06 - ILL\_130\_Roadway\_Plan\_Sheets

**Bartlett & West**  
 1207 SINCLAIR DRIVE, SUITE 2 - JERSEYVILLE, IL 62052  
 PHONE: 618-684-6001  
 ILLINOIS DESIGN FIRM NO. 19-000036-0002  
 WWW.BARTLETTWEST.COM

USER NAME =	ajc01914	DESIGNED -		REVISED -	
DRAWN -		DRAWN -		REVISED -	
PLOT SCALE =	49,999990000' / in.	CHECKED -		REVISED -	
PLOT DATE =	4/4/2023	DATE -		REVISED -	

**STATE OF ILLINOIS  
 DEPARTMENT OF TRANSPORTATION**

**ROADWAY PLANS**

SCALE: 50 SHEET 9 OF 10 SHEETS STA. 155+00.00 TO STA. 185+00.00

F.A.P. RTE.	SECTION	COUNTY	TOTAL SHEETS	SHEET NO.
820	(22,5)RS-3	COLES	34	19
CONTRACT NO. 74B23				
ILLINOIS FED. AID PROJECT				



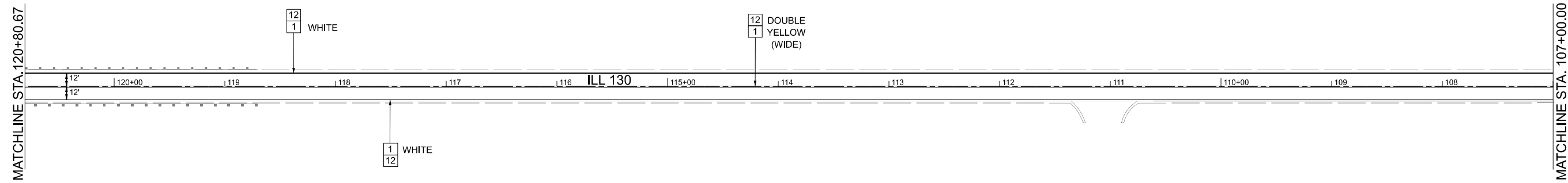
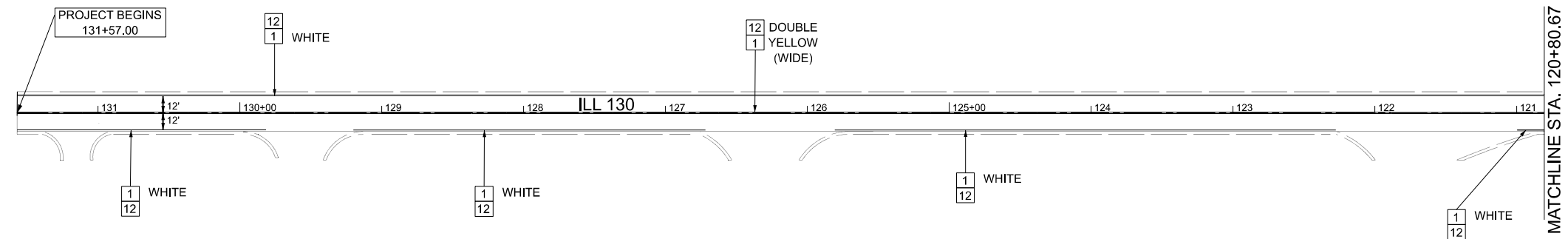

LEGEND

THERMOPLASTIC PAVEMENT MARKING		GROOVING FOR RECESSED PAVEMENT MARKING	
1	LINE 4"	12	5"
2	LINE 6"	13	7"
3	LINE 8"	14	9"
4	LINE 12"	15	13"
5	LINE 24"	16	25"
6	LETTER AND SYMBOLS	17	LETTER AND SYMBOLS

\* PAVEMENT MARKINGS ARE SHOWN FOR QUANTITY PURPOSE ONLY.  
 CONTRACTOR SHALL MATCH EXISTING PAVEMENT MARKINGS IN THE FIELD

**Bartlett & West**  
 1207 SINGLARI DRIVE, SUITE 2 - JERSEYVILLE, IL 62052  
 PHONE: 618-664-6991  
 ILLINOIS DESIGN FIRM NO. 154006555-0002  
 WWW.BARTLETTWEST.COM

USER NAME =	ajc01914	DESIGNED -	REVISED -
DRAWN -		DRAWN -	REVISED -
PLOT SCALE =	49.999990000 "/in.	CHECKED -	REVISED -
PLOT DATE =	4/4/2023	DATE -	REVISED -

**STATE OF ILLINOIS  
 DEPARTMENT OF TRANSPORTATION**

**PAVEMENT MARKING PLANS**

SCALE: 50 SHEET 1 OF 10 SHEETS STA. 131+57.00 TO STA. 107+00.00

F.A.P. RTE.	SECTION	COUNTY	TOTAL SHEETS	SHEET NO.
820	(22.5)RS-3	COLES	34	21
CONTRACT NO. 74B23				
ILLINOIS FED. AID PROJECT				

MODEL: ILL 130-A2 - Plan (Sheet)  
 FILE NAME: p:\baw\mwp\acomb\by.com\bartwest\paw\Documents\Plan Sheets\07 - ILL 130 - Pavement Marking Sheets

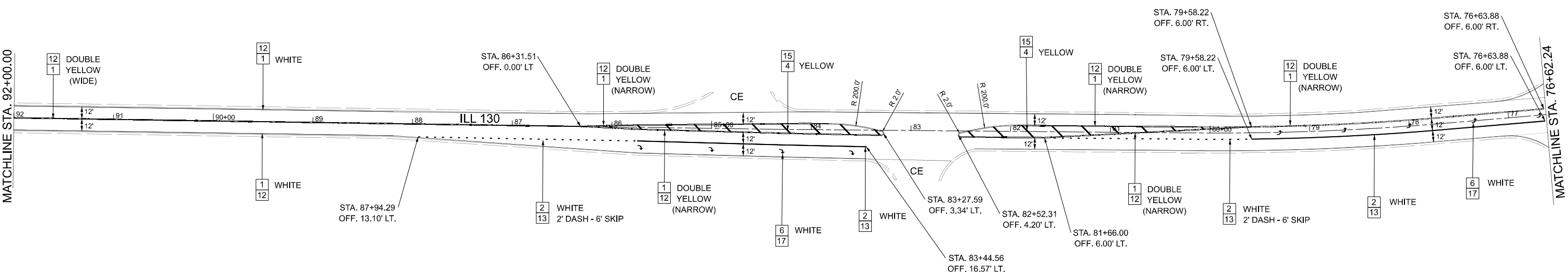
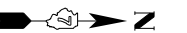
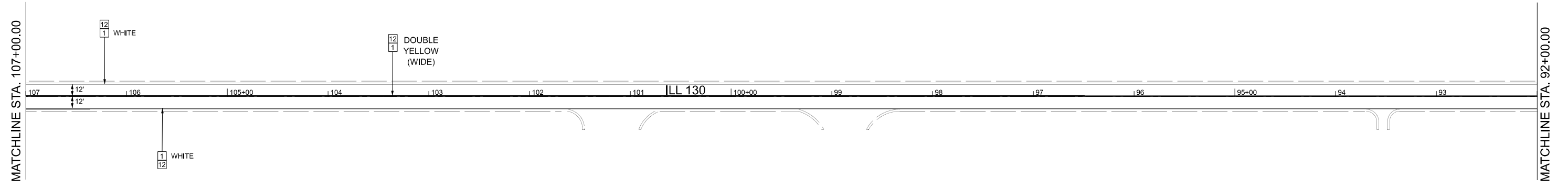
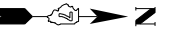

**LEGEND**

THERMOPLASTIC PAVEMENT MARKING		GROOVING FOR RECESSED PAVEMENT MARKING	
1	LINE 4"	12	5"
2	LINE 6"	13	7"
3	LINE 8"	14	9"
4	LINE 12"	15	13"
5	LINE 24"	16	25"
6	LETTER AND SYMBOLS	17	LETTER AND SYMBOLS

\* PAVEMENT MARKINGS ARE SHOWN FOR QUANTITY PURPOSE ONLY.  
CONTRACTOR SHALL MATCH EXISTING PAVEMENT MARKINGS IN THE FIELD

MODEL: ILL 130-A2 - Plan 3 (Sheet)  
 FILE NAME: p:\databases\pavement\pavement\Documents\Plan\92000\2023\2023-11-13\_Pavement Marking Sheets

**Bartlett & West**  
 1207 SINGULAR DRIVE, SUITE 2 - JERSEYVILLE, IL 62052  
 PHONE: 618-664-6091  
 ILLINOIS DESIGN FIRM NO. 154066555-0002  
 WWW.BARTLETTWEST.COM

USER NAME	= ajc01914	DESIGNED -	REVISED -
DRAWN -		REVISOR -	
PLOT SCALE = 49,999990000 "/in.		CHECKED -	REVISED -
PLOT DATE = 4/4/2023		DATE -	REVISED -

**STATE OF ILLINOIS  
DEPARTMENT OF TRANSPORTATION**

**PAVEMENT MARKING PLANS**

SCALE: 50      SHEET 2 OF 10 SHEETS      STA. 107+00.00 TO STA. 76+62.24

F.A.P. RTE.	SECTION	COUNTY	TOTAL SHEETS	SHEET NO.
820	(22.5)RS-3	COLES	34	22
CONTRACT NO. 74B23				
ILLINOIS FED. AID PROJECT				

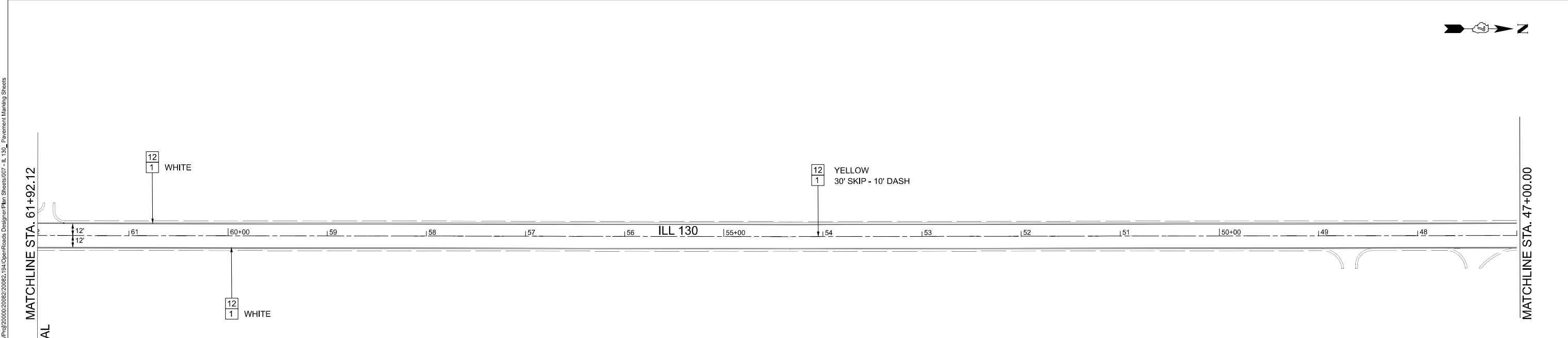
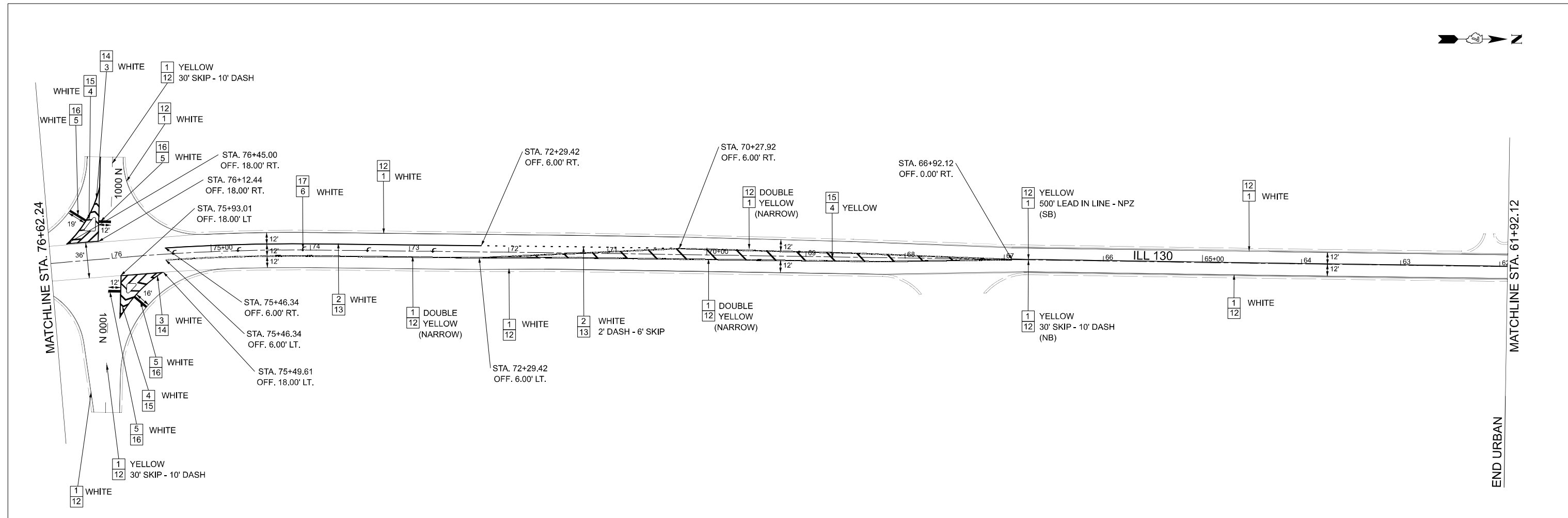

**LEGEND**

THERMOPLASTIC PAVEMENT MARKING		GROOVING FOR RECESSED PAVEMENT MARKING	
1 LINE 4"		12 5"	
2 LINE 6"		13 7"	
3 LINE 8"		14 9"	
4 LINE 12"		15 13"	
5 LINE 24"		16 25"	
6 LETTER AND SYMBOLS		17 LETTER AND SYMBOLS	

\* PAVEMENT MARKINGS ARE SHOWN FOR QUANTITY PURPOSE ONLY.  
CONTRACTOR SHALL MATCH EXISTING PAVEMENT MARKINGS IN THE FIELD

MODEL ILL 130-A2-Plan 0 [Sheet]  
FILE NAME: p:\databases\pavement\pavement\Documents\Plan Sheets\07 - ILL 130 - Pavement Marking Sheets

**Bartlett & West**  
1207 SINCLAIR DRIVE, SUITE 2 - JERSEYVILLE, IL 62052  
PHONE: 618-664-6991  
ILLINOIS DESIGN FIRM NO. 124000555-0002  
WWW.BARTLETTWEST.COM

USER NAME =	ajc01914	DESIGNED -	REVISED -
DRAWN -		DRAWN -	REVISED -
PLOT SCALE =	49,999990000' / in.	CHECKED -	REVISED -
PLOT DATE =	4/4/2023	DATE -	REVISED -

**STATE OF ILLINOIS  
DEPARTMENT OF TRANSPORTATION**

**PAVEMENT MARKING PLANS**

SCALE: 50 SHEET 3 OF 10 SHEETS STA. 76+62.24 TO STA. 48+00.0

F.A.P. RTE.	SECTION	COUNTY	TOTAL SHEETS	SHEET NO.
820	(22.5)RS-3	COLES	34	23
CONTRACT NO. 74B23				
ILLINOIS FED. AID PROJECT				

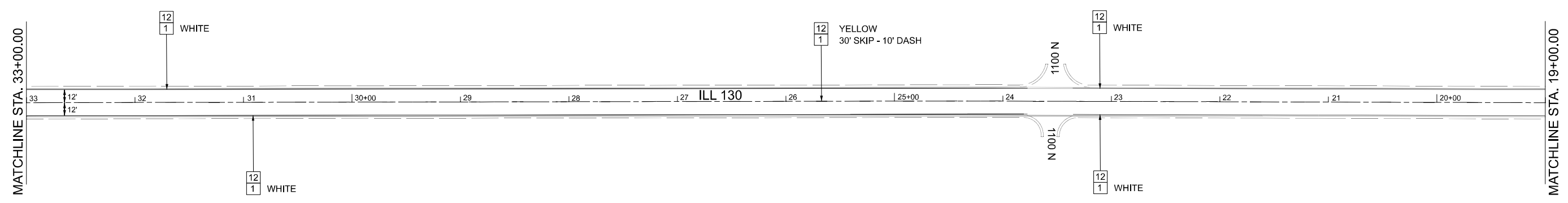
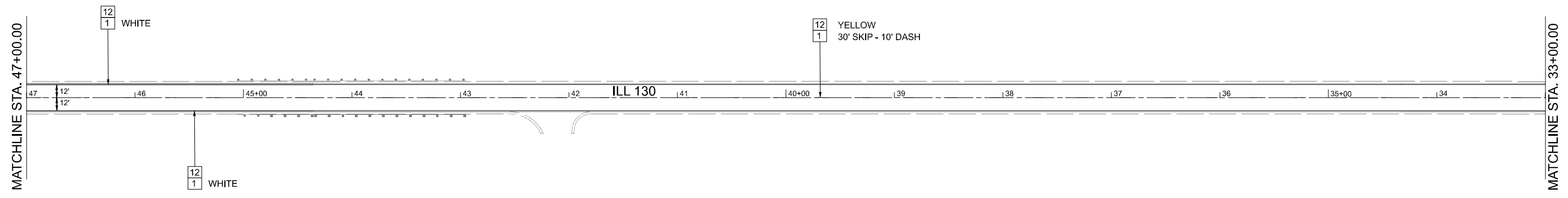

LEGEND

THERMOPLASTIC PAVEMENT MARKING		GROOVING FOR RECESSED PAVEMENT MARKING	
1 LINE 4"		12 5"	
2 LINE 6"		13 7"	
3 LINE 8"		14 9"	
4 LINE 12"		15 13"	
5 LINE 24"		16 25"	
6 LETTER AND SYMBOLS		17 LETTER AND SYMBOLS	

\* PAVEMENT MARKINGS ARE SHOWN FOR QUANTITY PURPOSE ONLY.  
CONTRACTOR SHALL MATCH EXISTING PAVEMENT MARKINGS IN THE FIELD

**Bartlett & West**  
 1207 SINCLAIR DRIVE, SUITE 2 - JERSEYVILLE, IL 62652  
 PHONE 618-694-6091  
 ILLINOIS DESIGN FIRM NO. 14-000005-0002  
 WWW.BARTLETTWEST.COM

USER NAME =	ajc01914	DESIGNED -	REVISED -
		DRAWN -	REVISED -
PLOT SCALE =	49.999990000 "/in.	CHECKED -	REVISED -
PLOT DATE =	4/4/2023	DATE -	REVISED -

**STATE OF ILLINOIS  
DEPARTMENT OF TRANSPORTATION**

**PAVEMENT MARKING PLANS**

SCALE: 50 SHEET 4 OF 10 SHEETS STA. 47+00.00 TO STA. 19+00.00

F.A.P. RTE.	SECTION	COUNTY	TOTAL SHEETS	SHEET NO.
820	(22.5)RS-3	COLES	34	24
CONTRACT NO. 74B23				
ILLINOIS FED. AID PROJECT				

MODEL: ILL 130 - A2 - Plan 7 (Sheet)  
 FILE NAME: p:\databases\pavement\pavement\Documents\Plan Sheets\07 - ILL 130 - Pavement Marking Sheets







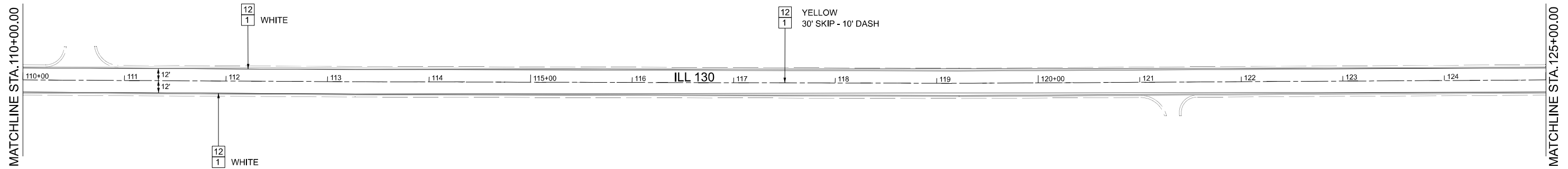
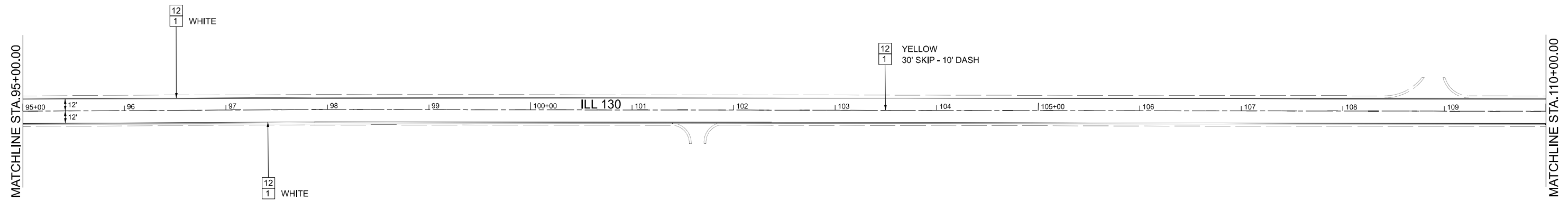

LEGEND

THERMOPLASTIC PAVEMENT MARKING	GROOVING FOR RECESSED PAVEMENT MARKING
1 LINE 4"	12 5"
2 LINE 6"	13 7"
3 LINE 8"	14 9"
4 LINE 12"	15 13"
5 LINE 24"	16 25"
6 LETTER AND SYMBOLS	17 LETTER AND SYMBOLS

\* PAVEMENT MARKINGS ARE SHOWN FOR QUANTITY PURPOSE ONLY.  
 CONTRACTOR SHALL MATCH EXISTING PAVEMENT MARKINGS IN THE FIELD

**Bartlett & West**

USER NAME =	ajc01914	DESIGNED -	REVISED -
PLOT SCALE =	49.99990000" / in.	DRAWN -	REVISED -
PLOT DATE =	4/4/2023	CHECKED -	REVISED -
		DATE -	REVISED -

STATE OF ILLINOIS  
 DEPARTMENT OF TRANSPORTATION

PAVEMENT MARKING PLANS

SCALE: 50 SHEET 7 OF 10 SHEETS STA. 95+00.00 TO STA. 125+00.00

F.A.P. RTE.	SECTION	COUNTY	TOTAL SHEETS	SHEET NO.
820	(22,5)RS-3	COLES	34	27
CONTRACT NO. 74B23				
ILLINOIS FED. AID PROJECT				

MODEL: ILL 130 - A2 - Plan 13 (Sheet)  
 FILE NAME: \\w01\work\pavement\130\Documents\Plan\130\_Pavement Marking Sheets\07 - ILL 130\_Pavement Marking Sheets





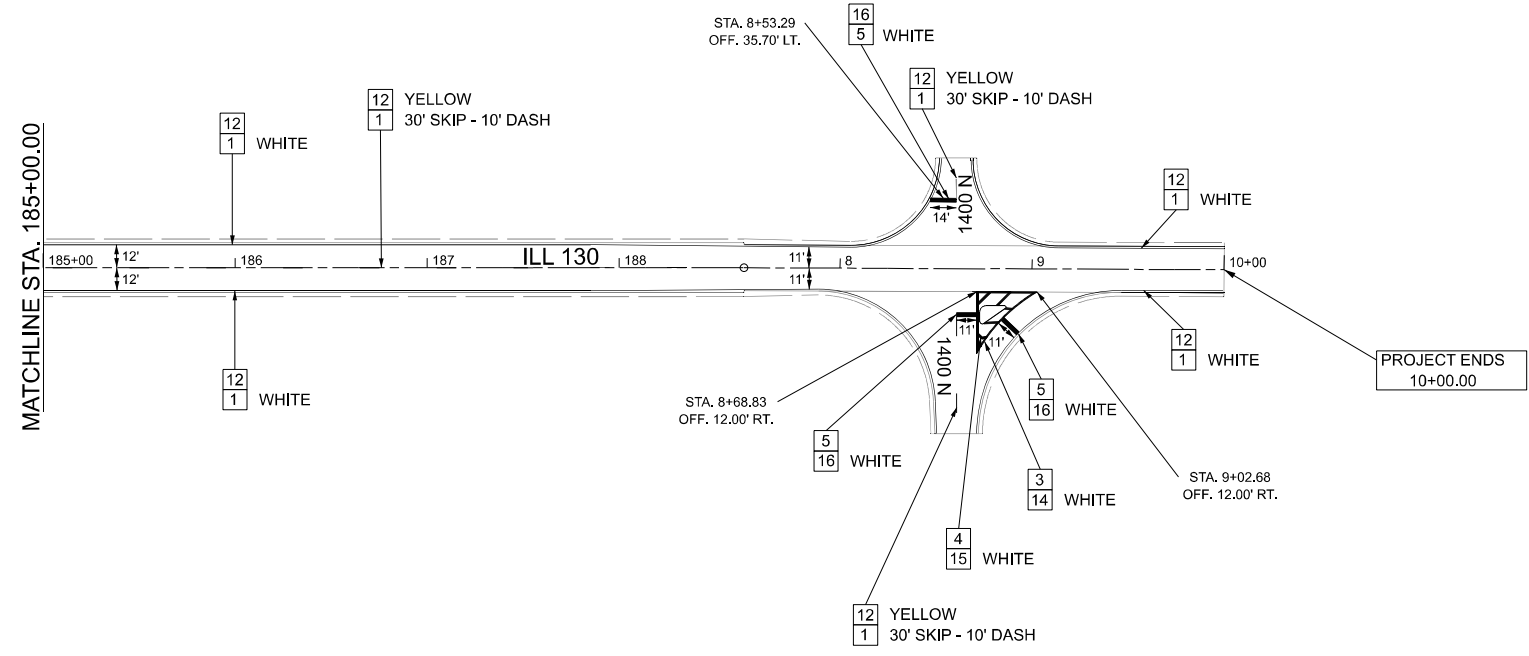

MODEL ILL 130 - A2 - Plan 19 [Sheet]  
 FILE NAME: p:\barlow\pavement\pavement\Documents\Plan Sheets\07 - ILL 130 - Pavement Marking Sheets

\* PAVEMENT MARKINGS ARE SHOWN FOR QUANTITY PURPOSE ONLY.  
 CONTRACTOR SHALL MATCH EXISTING PAVEMENT MARKINGS IN THE FIELD

LEGEND

THERMOPLASTIC PAVEMENT MARKING	GROOVING FOR RECESSED PAVEMENT MARKING
1 LINE 4"	12 5"
2 LINE 6"	13 7"
3 LINE 8"	14 9"
4 LINE 12"	15 13"
5 LINE 24"	16 25"
6 LETTER AND SYMBOLS	17 LETTER AND SYMBOLS

**Bartlett & West**

USER NAME =	ajc01914	DESIGNED -	REVISED -
		DRAWN -	REVISED -
PLOT SCALE =	49.99990000" / in.	CHECKED -	REVISED -
PLOT DATE =	4/4/2023	DATE -	REVISED -

**STATE OF ILLINOIS  
 DEPARTMENT OF TRANSPORTATION**

**PAVEMENT MARKING PLANS**

SCALE: 50 SHEET 10 OF 10 SHEETS STA. 185+00.00 TO STA. 10+00.00

F.A.P. RTE.	SECTION	COUNTY	TOTAL SHEETS	SHEET NO.
820	(22.5)RS-3	COLES	34	30
CONTRACT NO. 74B23				
		ILLINOIS	FED. AID PROJECT	









FILE NAME = p:\bar\west\c\bar\west\p\01\Documents\Proj\200802\200802194\OpenRoads Designer\Plan Sheets\2008 - IL 130 - D7 Std 76000001.dgn

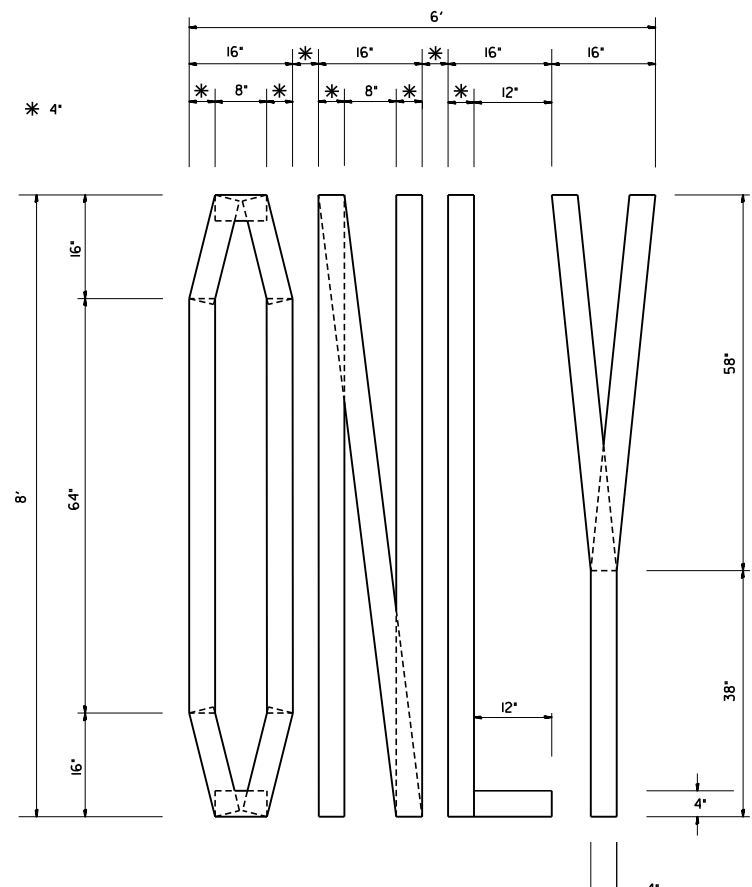

QUANTITY  
4" LINE = 63.2 ft.  
21.0 sq. ft.

SHORT TERM STOP BAR

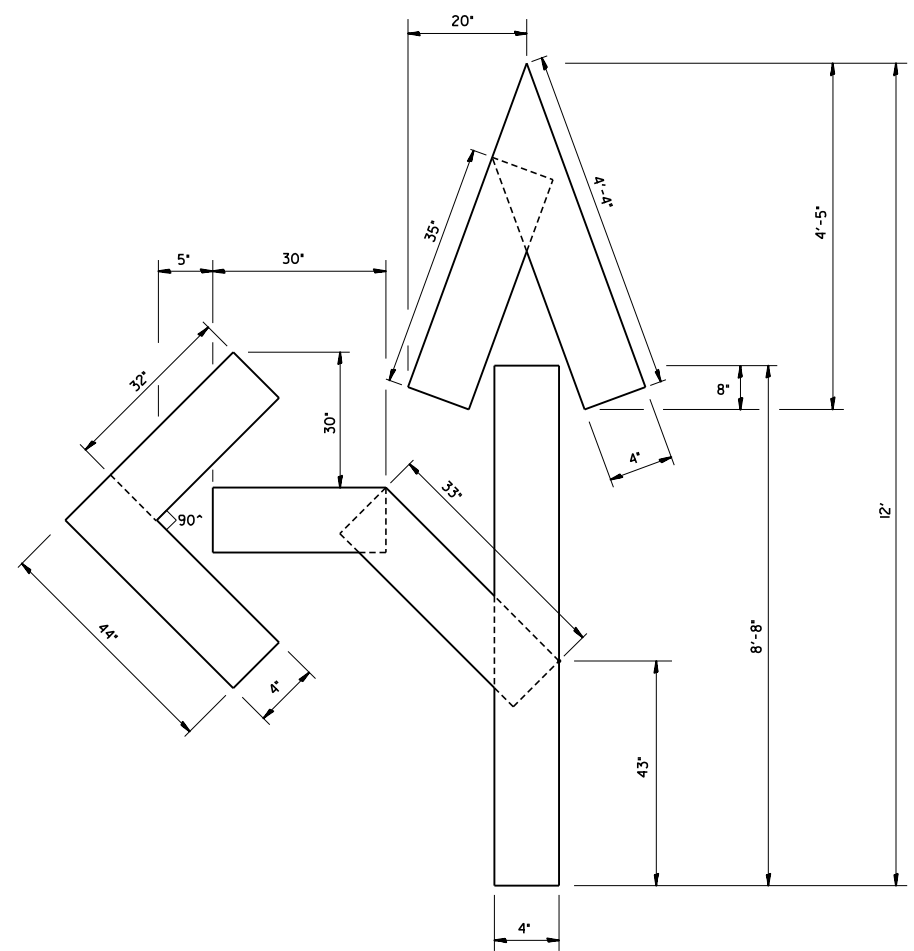
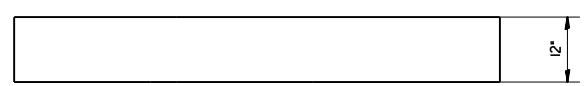

QUANTITY  
4" LINE = 27.5 ft.  
9.2 sq. ft.

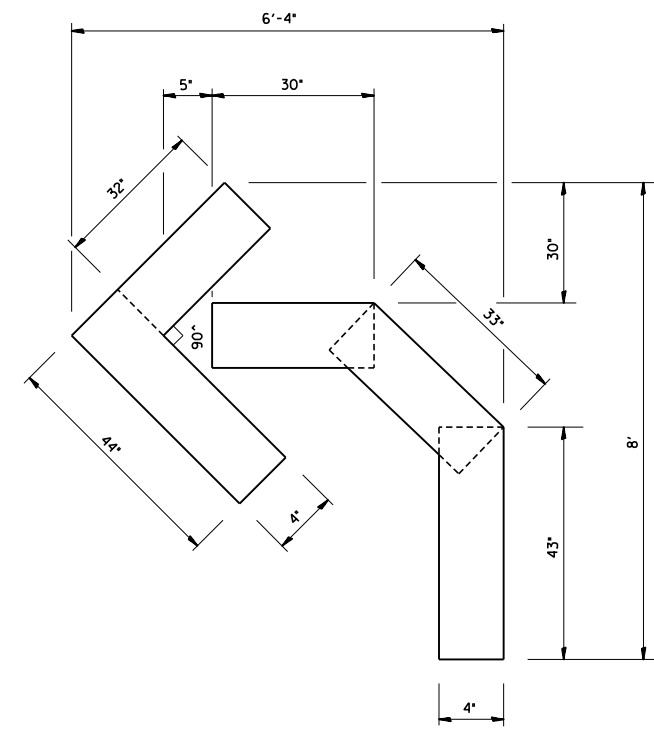

QUANTITY  
4" LINE = 15.2 ft.  
5.0 sq. ft.

USER NAME = a_jc01914	DESIGNED -	REVISED -
PLOT SCALE = 1:8000' / 1"	DRAWN -	REVISED -
PLOT DATE = 4/3/2023	CHECKED -	REVISED -
	DATE -	REVISED -

F.A.P. RTE.	SECTION	COUNTY	TOTAL SHEETS	SHEET NO.
820	(22,5)RS-3	COLES	34	34
CONTRACT NO. 74B23				
ILLINOIS FED. AID PROJECT				