

STATE OF ILLINOIS
DEPARTMENT OF TRANSPORTATION

FAP	SECTION	COUNTY	POST MILE	SHEET	SHEET NO. 3
337	20R-5	LAKE	562	215	3 SHEETS
FED. ROAD DIST. NO. 7	ALLIANCE	FED. AID PROJECT			
0-91-552-99		Contract No. 60881			

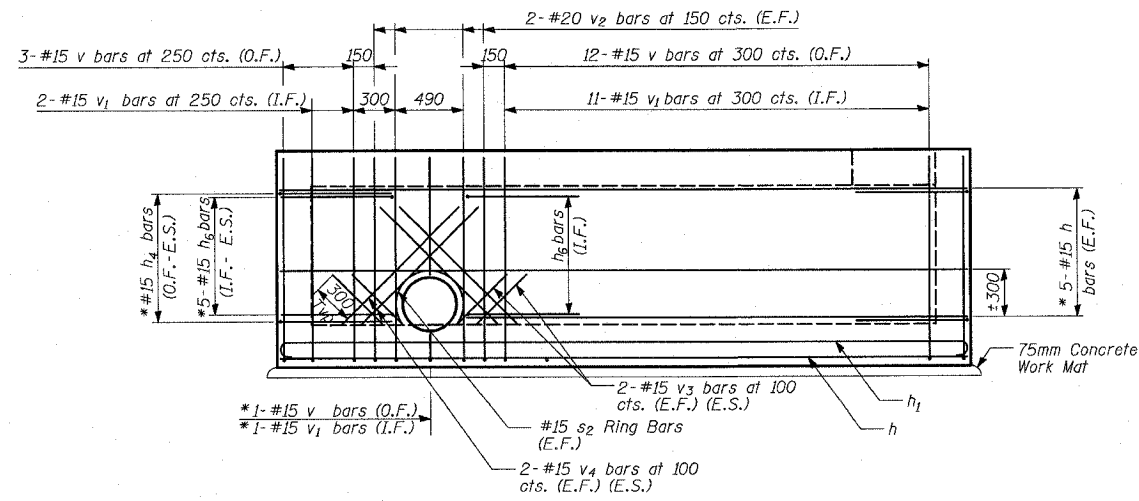

SECTION E-E

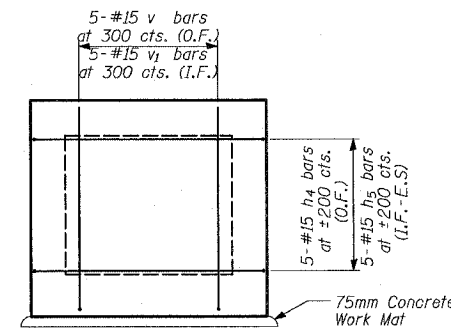

SECTION G-G

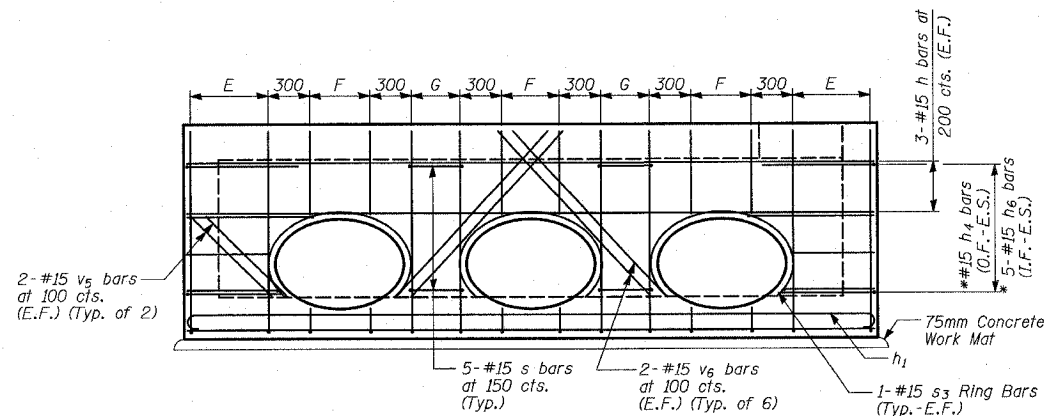

SECTION F-F

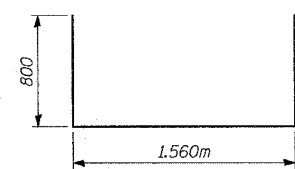

BAR h4

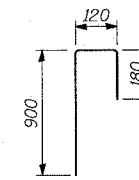

BAR h6

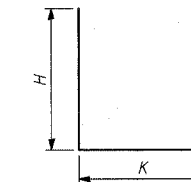

BARS v, v1 & v2

Bar	H	K
v	1.42m	650
v1	1.42m	260
v2	1.42m	700

BILL OF MATERIAL

Bar	No.	Size	Length (m)	Shape
a	34	#15	1.60	—
a1	41	#20	2.04	—
a2	3	#20	1.60	—
a3	2	#20	1.90	—
a4	4	#20	1.97	—
a5	8	#20	0.89	—
a6	12	#15	1.50	—
a7	4	#15	0.72	—
h	28	#15	4.90	—
h1	7	#20	5.34	—
h2	3	#20	4.90	—
h3	10	#15	5.26	—
h4	10	#15	3.16	—
h5	10	#15	1.60	—
h6	20	#15	1.20	—
s	10	#15	1.22	—
s1	2	#15	2.84	—
s2	2	#15	1.09	—
s3	6	#15	1.96	—
v	32	#15	2.07	—
v1	30	#15	1.68	—
v2	32	#20	2.12	—
v3	8	#15	0.62	—
v4	8	#15	1.20	—
v5	8	#15	0.83	—
v6	24	#15	1.63	—
Concrete Structures			CU M	8
Reinforcement Bars			KG	1,400

NOTES:

1. Reinforcement bar clearance to be 50mm unless otherwise noted.

E.F. - denotes Each Face
E.S. - denotes Each Side
I.F. - denotes Inside Face
O.F. - denotes Outside Face

* Cut bars to fit in field

E	3-#20 v2 bars at 280 cts. (E.F.)
F	*2-#15 v bars at 200 cts. (O.F.) *2-#15 v1 bars at 200 cts. (I.F.)
G	3-#20 v2 bars at 150 cts. (E.F.)

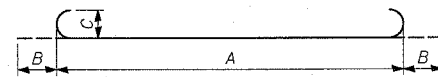

BARS a1, h1 & h3

Bar	A	B	C
a1	1.60m	220	160
h1	4.90m	220	160
h3	4.90m	180	130

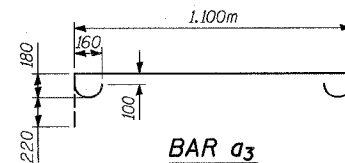

BAR a3

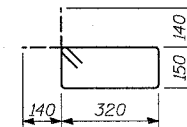

BAR s

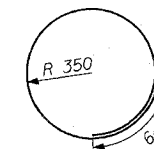

BAR s1

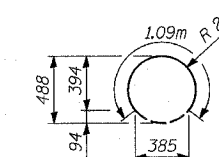

BAR s2

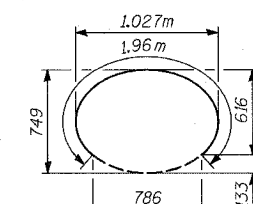

BAR s3

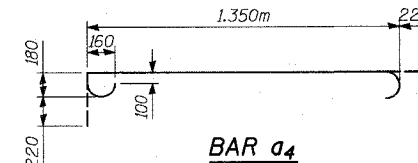

BAR a4

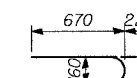

BAR a5

TYLIN INTERNATIONAL

DESIGNED	MI, MAF
CHECKED	TD
DRAWN	MAF, BK
CHECKED	TD
DATE	03-22-2004

DETAILS 2

JUNCTION CHAMBER 1
STA. 103+408.940
IL ROUTE 22
FAP 337 SECTION 20R-5
IL RTE 83 TO US 45/IL 21
LAKE COUNTY