

STATE OF ILLINOIS
DEPARTMENT OF TRANSPORTATION

FAP	SECTION	QUANTITY	UNIT	PRICE	SHEET NO. 3
337	20R-5	LAKE	562	227	3 SHEETS
ILLINOIS PROJECT					Contract No. 60881
FED. ROAD DIST. NO. 7					0-91-552-99

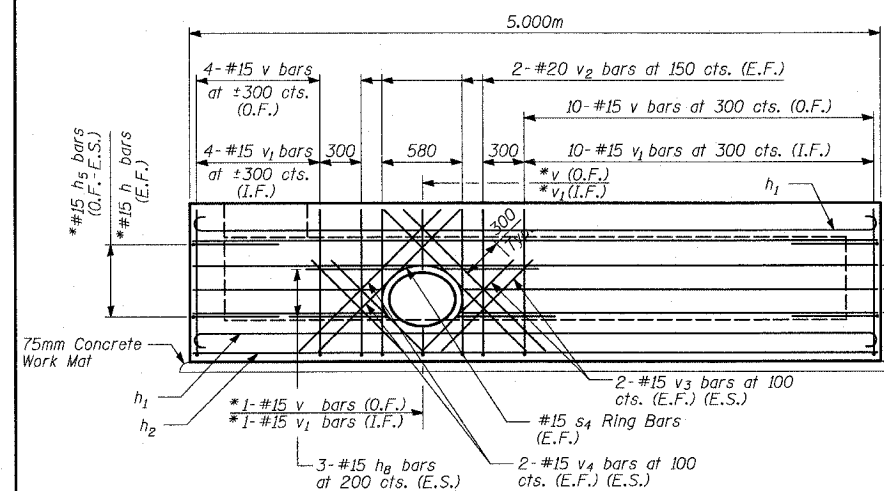

SECTION F-F

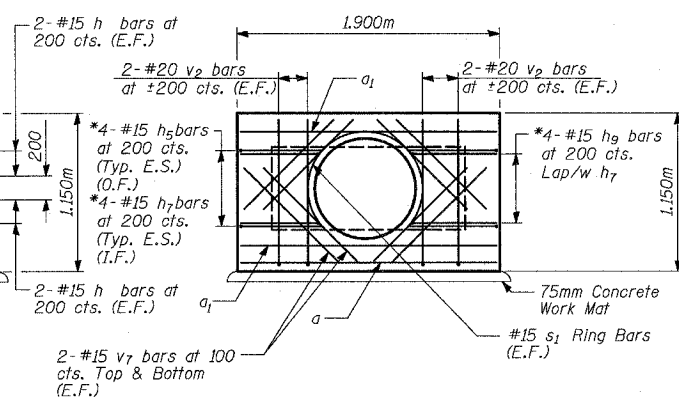

SECTION H-H

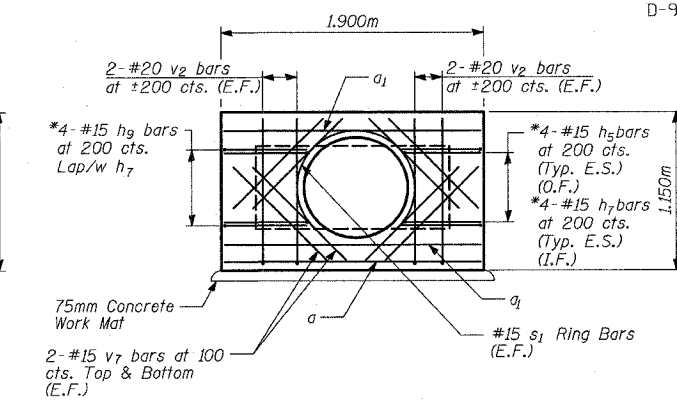

SECTION J-J

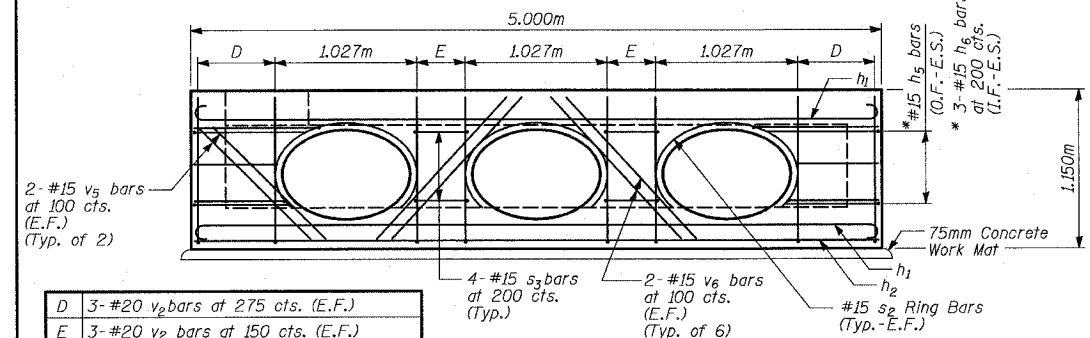

SECTION G-G

D	3- #20 v2 bars at 275 cts. (E.F.)
E	3- #20 v2 bars at 150 cts. (E.F.)

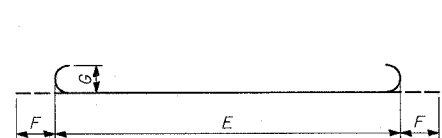

BARS a₁ & h₁

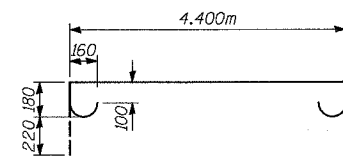

BAR h₃

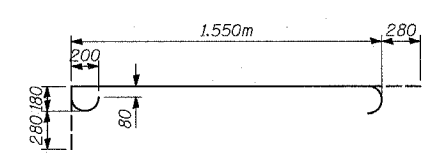

BAR a₅

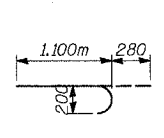

BAR a₆

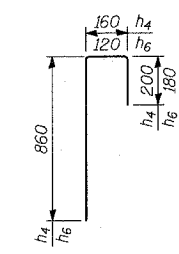

BARS h₄ & h₆

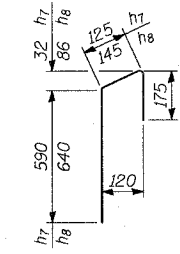

BARS h₇ & h₈

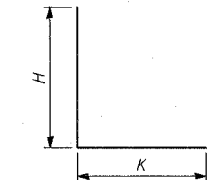

BARS h₅, v, v₁, v₂

Bar	E	F	G
a ₁	1.800m	280	200
h ₁	4.900m	220	160

Bar	H	K
h ₅	850	850
v	1.030m	640
v ₁	1.030m	320
v ₂	1.030m	680

TYLIN INTERNATIONAL

DESIGNED	MI, DJR
CHECKED	TD
DRAWN	DJR, BK
CHECKED	TD
DATE	03-22-2004

NOTES:
Reinforcement bar clearance to be 50mm unless otherwise noted.
E.F. - denotes Each Face
E.S. - denotes Each Side
I.F. - denotes Inside Face
O.F. - denotes Outside Face
* Cut bars to fit in field

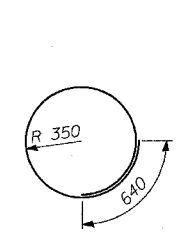

BAR s

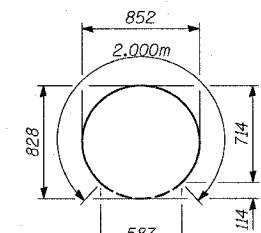

BAR s₁

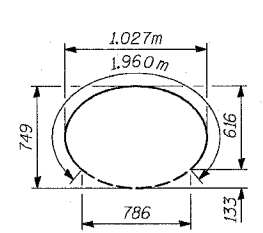

BAR s₂

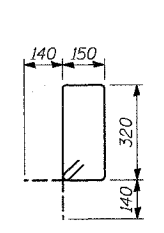

BAR s₃

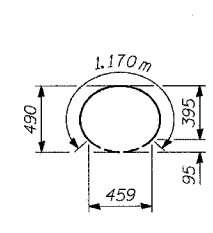

BAR s₄

DETAILS 2

JUNCTION CHAMBER 5
STA. 104+013.400
IL ROUTE 22
FAP 337 SECTION 20R-5
IL RTE 83 TO US 45/IL 21
LAKE COUNTY

BILL OF MATERIAL

Bar	No.	Size	Length (m)	Shape
a	32	#15	1.80	
a ₁	30	#25	2.36	
a ₂	3	#25	1.80	
a ₃	12	#15	1.50	
a ₄	4	#15	0.71	
a ₅	8	#25	2.29	
a ₆	8	#25	1.38	
h	15	#15	4.90	
h ₁	17	#20	5.34	
h ₂	11	#20	4.90	
h ₃	1	#20	5.20	
h ₄	2	#20	1.22	
h ₅	16	#15	1.70	
h ₆	6	#15	1.16	
h ₇	16	#15	0.89	
h ₈	6	#15	0.96	
h ₉	8	#15	0.59	
s	2	#15	2.84	
s ₁	4	#15	2.00	
s ₂	6	#15	1.96	
s ₃	8	#15	1.22	
s ₄	2	#15	1.17	
v	15	#15	1.67	
v ₁	15	#20	1.35	
v ₂	48	#20	1.71	
v ₃	8	#15	0.93	
v ₄	8	#15	1.45	
v ₅	8	#15	1.15	
v ₆	24	#15	1.39	
v ₇	32	#15	0.93	
Concrete Structures			CU M	7
Reinforcement Bars			KG	1,590