

PLAN

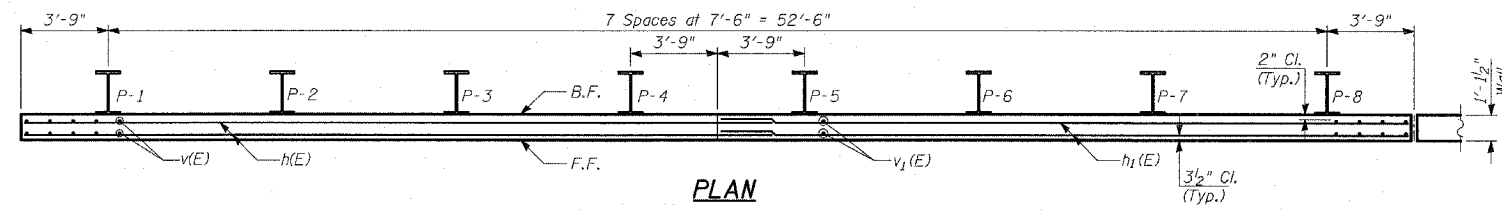

PLAN

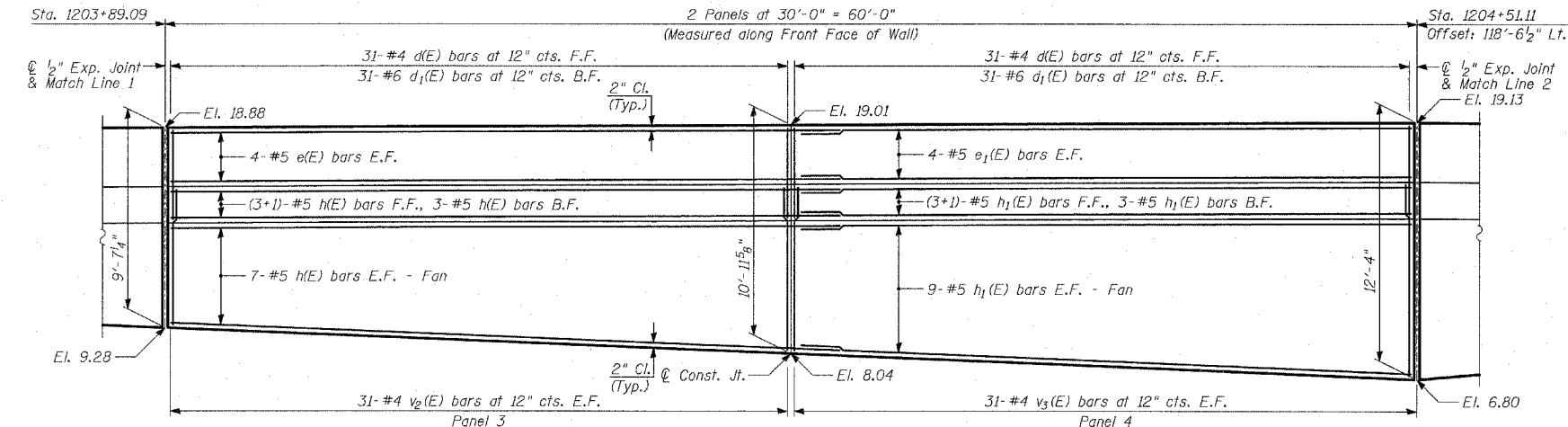

PLAN

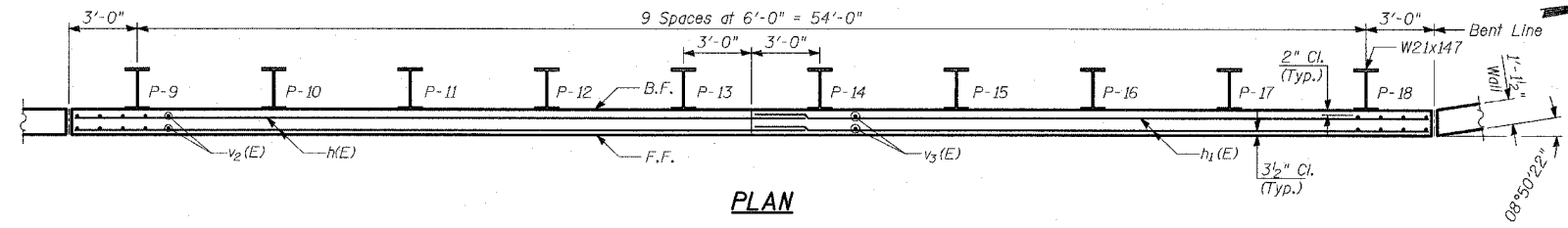

PLAN

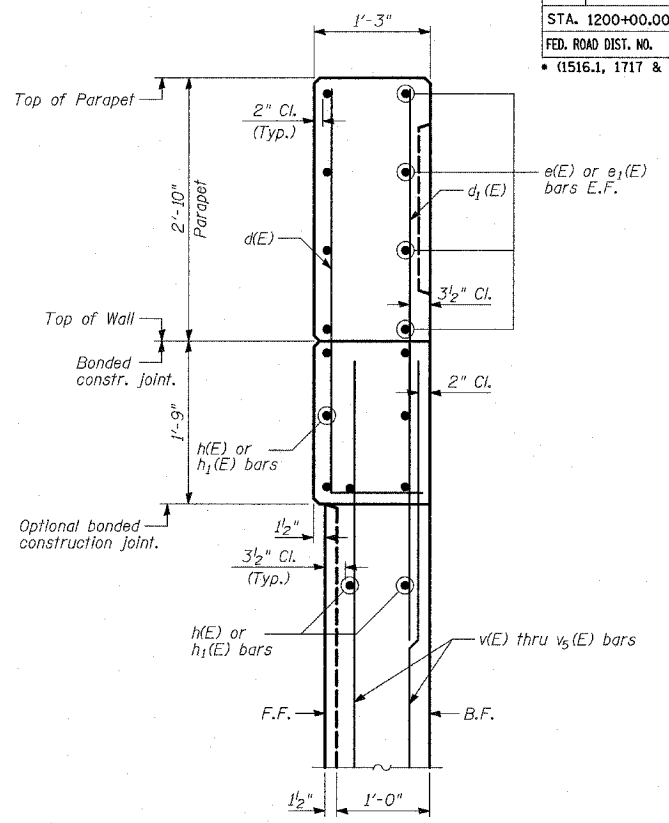

FLUTED PARAPET DETAIL

- NOTES:**
1. B.F. - denotes Back Face.
 2. E.F. - denotes Each Face.
 3. F.F. - denotes Front Face.
 4. Work this Sheet with Sheets 3 thru 8 of 10.
 5. Pile spacing measured along front face of wall.
 6. For Lap Splices, see Sheet 3 of 10.

TYLIN INTERNATIONAL

REVISIONS	
NAME	DATE

ILLINOIS DEPARTMENT OF TRANSPORTATION
 F.A.I. 94 (DAN RYAN EXPRESSWAY)
 RETAINING WALL ALONG LAFAYETTE AVE.
 AT 95TH ST.
 WALL 33 - PLAN AND ELEVATION
 STA. 1203+26.72 TO STA. 1204+51.11
 S.N. 016-W959 DESIGNED BY: MI, TB
 SCALE: N.T.S. DRAWN BY: DJR, TB
 DATE: MARCH 25, 2005 CHECKED BY: TD, MI