

N = Bolt Diameter	G	H
1/2"	2"	1 1/8"
5/8"	2 1/4"	1 1/4"
3/4"	2 1/2"	1 3/8"
7/8"	2 3/4"	1 1/2"
1"	3"	1 5/8"
1 1/8"	3 1/4"	1 3/4"

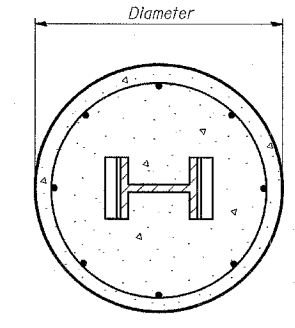
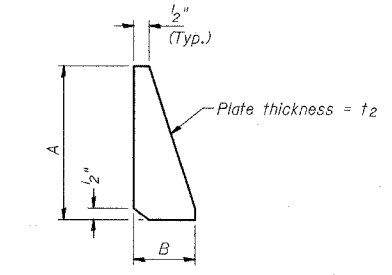
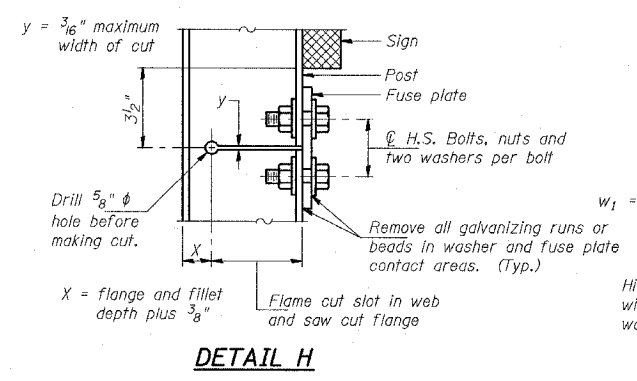
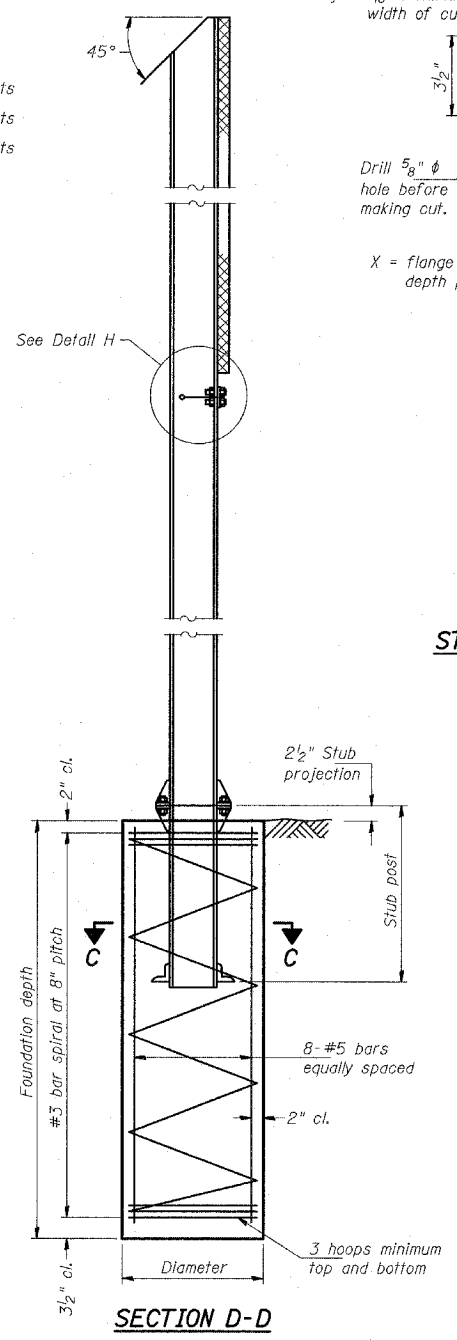

GENERAL NOTES

Posts shall be plumbed by using shims with post-to-stub post connection bolts snug tight only. Final tightening of all High Strength Bolts shall be in accordance with Article 505.04(f)(3), and threads at the junction of the bolt and nut shall be burred or center punched to prevent the nut from loosening.

LOADING: 80 m.p.h. wind with 30% gust factor, normal to sign.

DESIGN STRESSES:
 Structural steel - 20,000 p.s.i.
 Reinforcing steel - 20,000 p.s.i.
 Concrete - 1,400 p.s.i.
 Footing soil pressure - 2,000 p.s.f.

After fabrication, the post, fuse plate and upper 6" (Minimum) of the stub post shall be hot-dip galvanized in accordance with AASHTO M111. All bolts, nuts and washers shall be hot-dip galvanized in accordance with AASHTO M232.

Work this sheet with Base Sheet BAW-A-2.

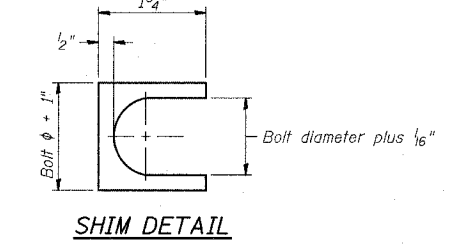
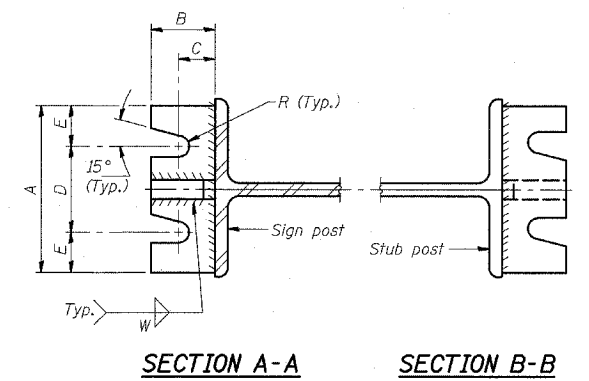
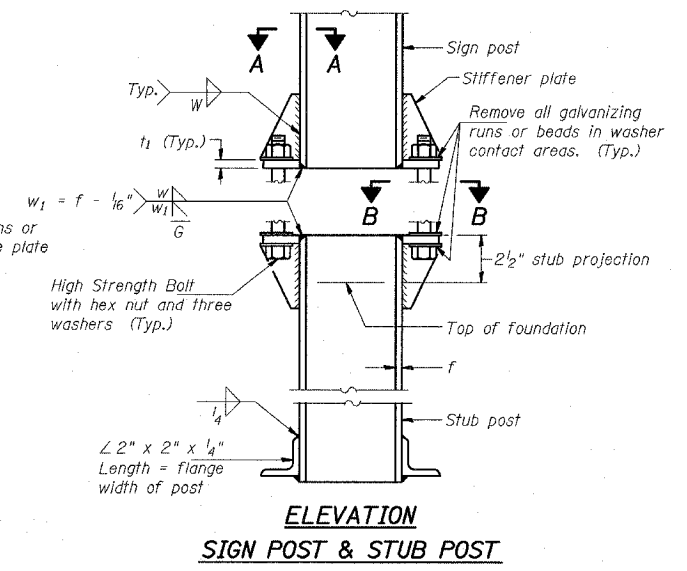

NUMBER	REVISION	DATE

BAW-A-1 11/1/2002

TYLIN INTERNATIONAL

REVISIONS	
NAME	DATE

ILLINOIS DEPARTMENT OF TRANSPORTATION
 F.A.I. 94 (DAN RYAN EXPRESSWAY)
 BREAK-AWAY WIDE FLANGE
 STEEL SIGN POST DETAILS

SCALE: AS NOTED DRAWN BY: AMB
 DATE: MARCH 25, 2005 CHECKED BY: TB