

**STABILIZED CONSTRUCTION ENTRANCE**  
N.T.S.

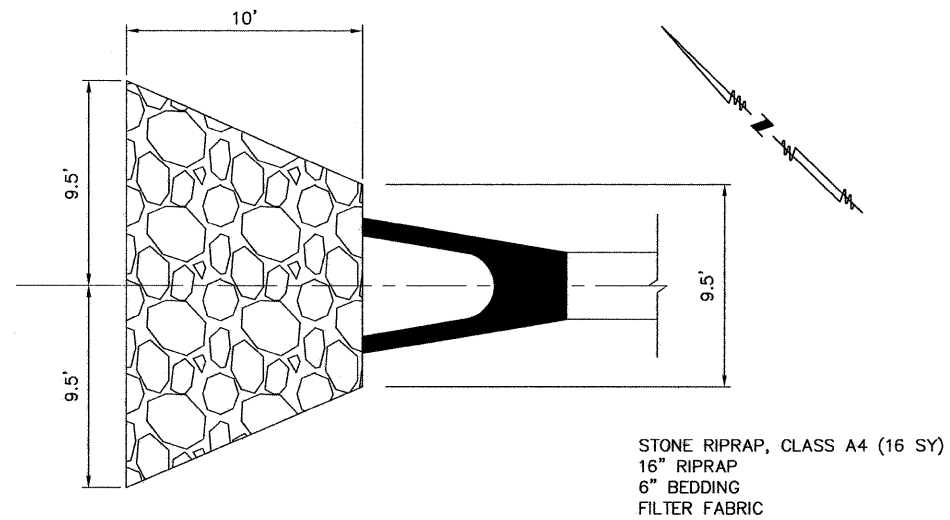

**RIPRAP AT 18" PRC FLARED END SECTION**

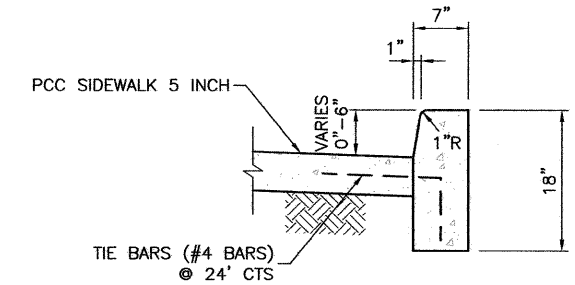

**BARRIER CURB ADJACENT TO PCC SIDEWALK 5 INCH**

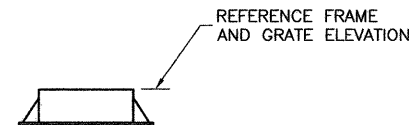

**FRAME AND LIDS, TYPE 1**

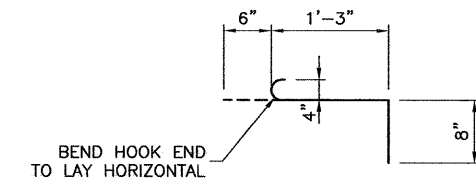

**TIE BAR (#4 BARS)**  
TIE BARS WILL BE PAID FOR EACH

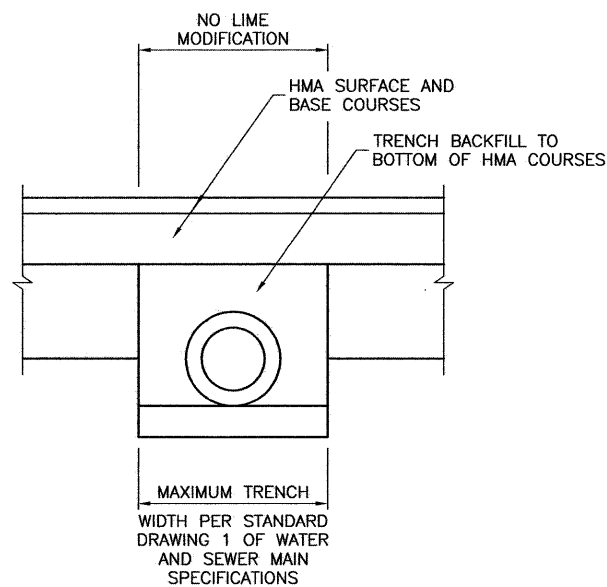

**BACKFILL DETAIL**

LINES 1-2, 10-11, 12-13  
17-18, 14-8, 15-7, 33-16  
19-EX PIPE AND 20-EX PIPE

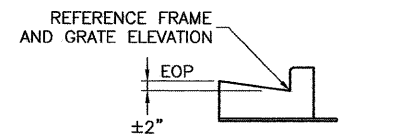

**FRAME AND GRATE, TYPE 3**

**REFERENCE FRAME AND GRATE ELEVATIONS**

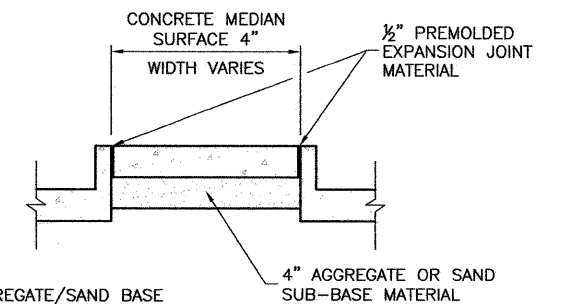

NOTE: COST OF AGGREGATE/SAND BASE AND JOINT MATERIAL SHALL BE INCLUDED IN THE COST OF CONCRETE MEDIAN SURFACE, 4 INCH

**CONCRETE MEDIAN SURFACE, 4 INCH**

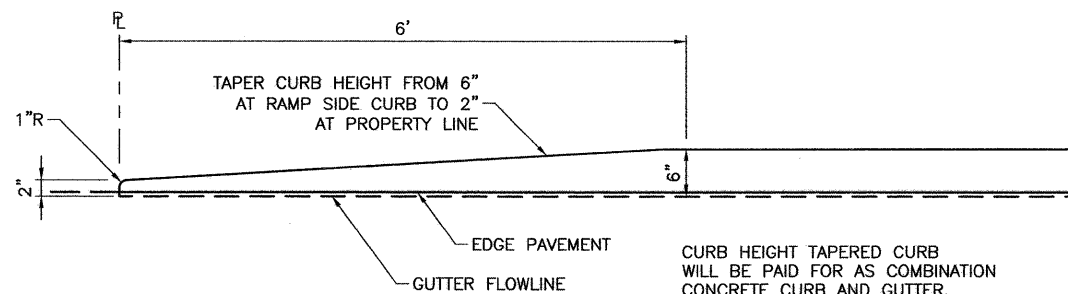

**CURB HEIGHT TAPER**

CURB HEIGHT TAPERED CURB WILL BE PAID FOR AS COMBINATION CONCRETE CURB AND GUTTER, TYPE B-6.18

SHEET TITLE	
<b>CONSTRUCTION DETAILS</b>	
PROJECT FAU RTE. 8046 (MEADOWBROOK ROAD) SECTION 09-00465-00-PP CITY OF SPRINGFIELD SANGAMON COUNTY	PROJECT NO. 09040 SCALE DATE 4/19/10 DRAWN BY PPW CHECKED BY
<b>Coombe-Bloxdorf P.C.</b> -CIVIL ENGINEERS- -STRUCTURAL ENGINEERS- -LAND SURVEYORS- Phone: 217/544-8477 Design Firm License No. 164-002703 755 South Grand Ave. W, Springfield, IL 62704	
DRAWING NO. <b>22</b> OF 30 SHTS	