

T.R. RTE.	SECTION	COUNTY	TOTAL SHEETS	SHEET NO.
50	05-03104-00-BR	JERSEY	12	6
CONTRACT NO. 97334				
FED. ROAD DIST. NO. - ILLINOIS FED. AID PROJECT				

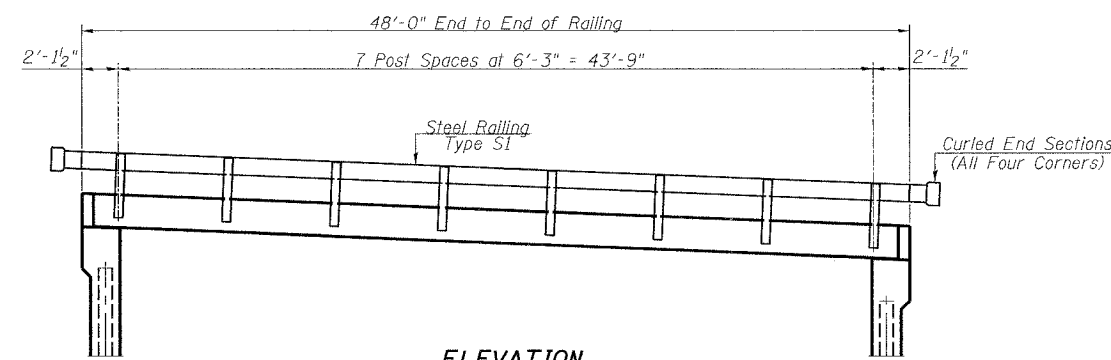

ELEVATION
(Showing Outside Face)

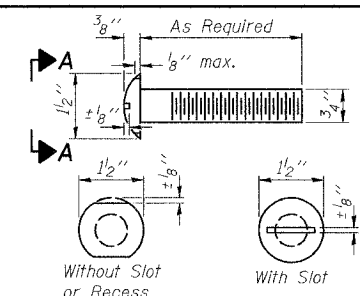

VIEW A-A
ROUND HEAD BOLT

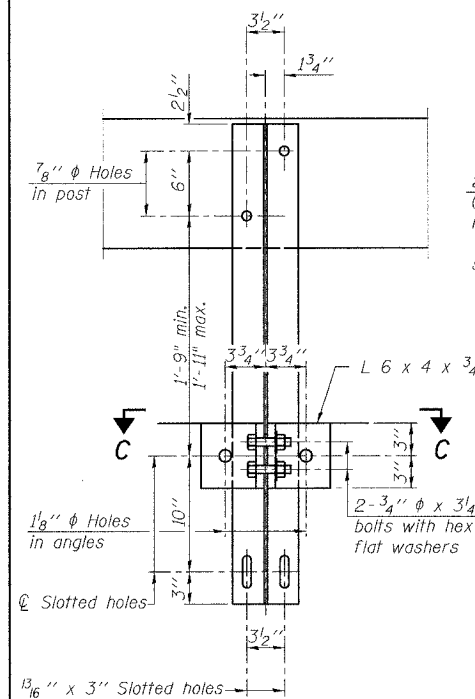

SECTION B-B

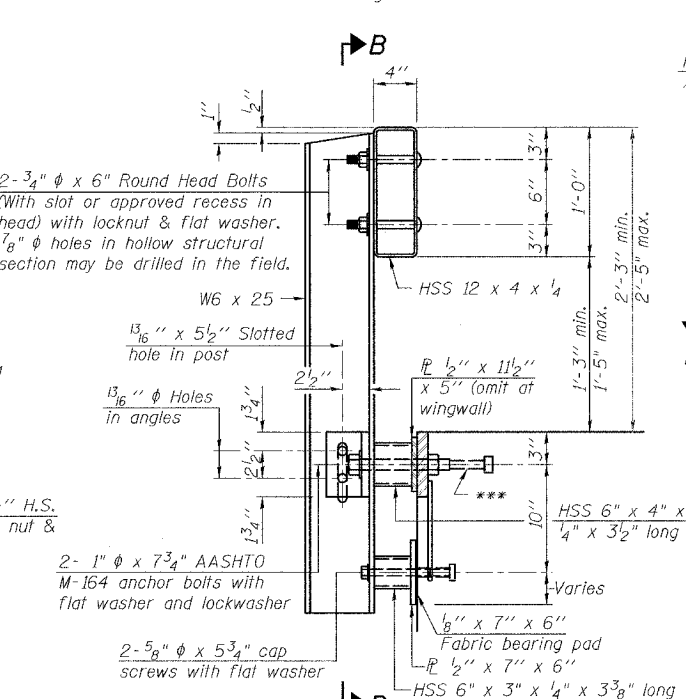

SECTION AT RAILING POST

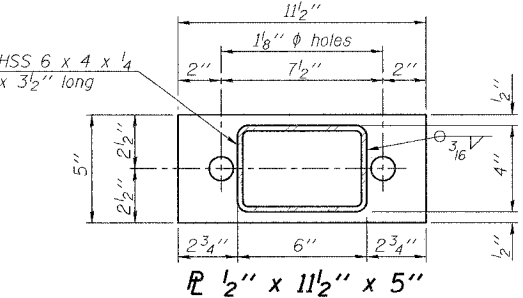

ANCHOR DEVICE

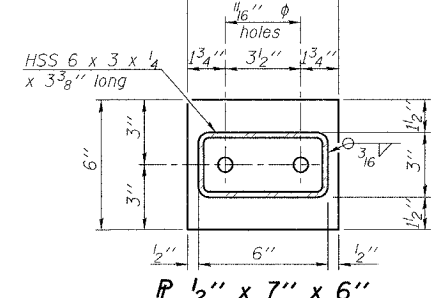

ANCHOR DEVICE

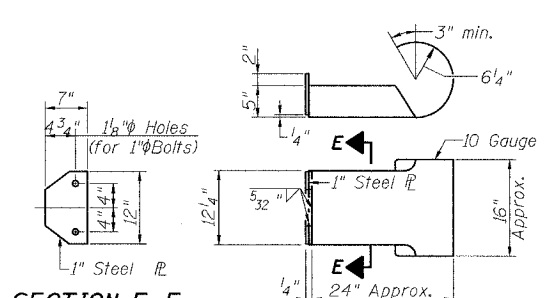

SECTION E-E
CURLED END SECTION DETAILS (4 Required)

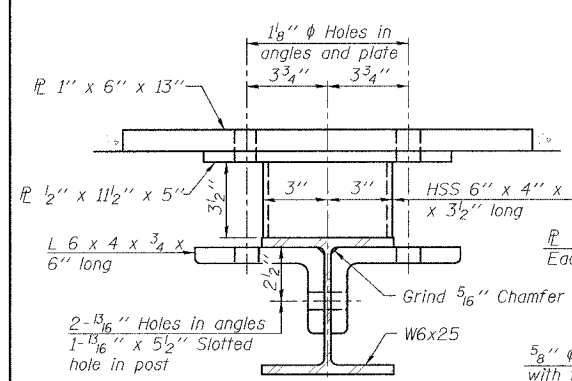

SECTION C-C

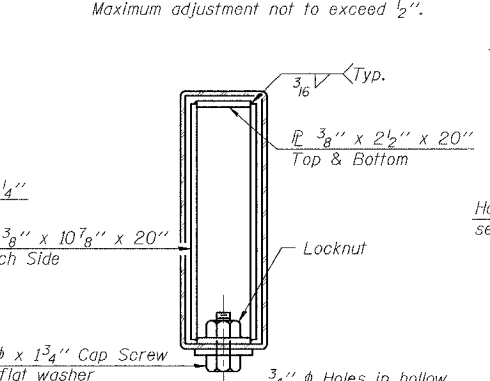

SECTIONS AT RAIL SPLICE

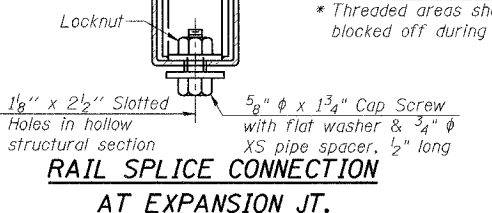

RAIL SPLICE CONNECTION AT EXPANSION JT.

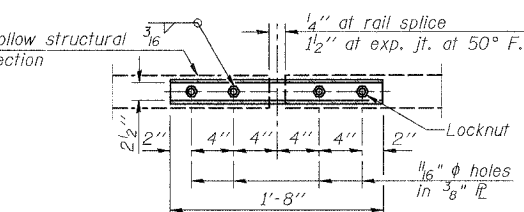

PLAN-BOTT. SPLICE TYPICAL

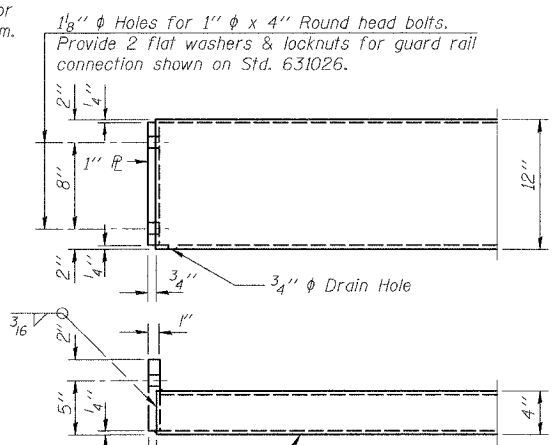

END OF RAIL DETAILS

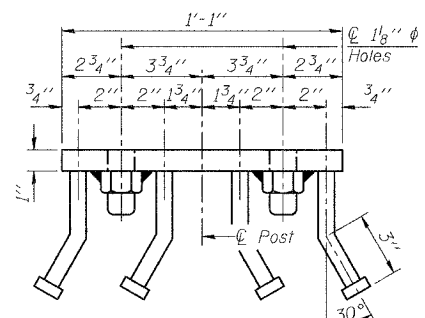

VIEW D-D
BILL OF MATERIAL

Item	Unit	Quantity
Steel Railing, Type S1	Foot	96

Notes:
 All field drilled holes shall be coated with an approved zinc rich paint before erection.
 All steel rail elements shall be galvanized according to Article 509.05 of the Standard Specifications.
 *** The studs of the anchor devices shall be placed below the top reinforcement bars and the outermost longitudinal reinforcement bar shall be placed directly above the studs of the rail post anchor device.
 Railing shall be in accordance with Section 509 of the Standard Specifications, except as noted, and will be paid for at the contract unit price per foot for Steel Railing, Type S-1.
 The cost of curled end sections shall be included in the cost of Steel Railing, Type S1.

FILE NAME =	USER NAME = #USER#	DESIGNED -	REVISED -
#FILE#		DRAWN -	REVISED -
	PLOT SCALE = #SCALE#	CHECKED -	REVISED -
	PLOT DATE = #DATE#	DATE -	REVISED -

Allen Henderson & Associates, Inc.
 Civil and Structural Engineers Springfield, IL.
 62703 Phone: (217)544-8033 IL. Design Firm
 No. 184-001907

RAILING			
SCALE: VARIES	SHEET NO. 6 OF 12 SHEETS	STA. 1+40.00 TO STA. 5+10.00	

T.R. RTE.	SECTION	COUNTY	TOTAL SHEETS	SHEET NO.
50	05-03104-00-BR	JERSEY	12	6
CONTRACT NO. 97334				
FED. ROAD DIST. NO. - ILLINOIS FED. AID PROJECT				