

**LEFT TURN LANE WITH APPROACH MEDIAN**

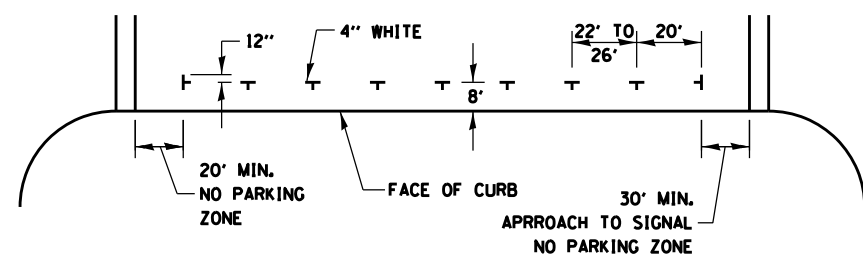

**PREFERRED METHOD**

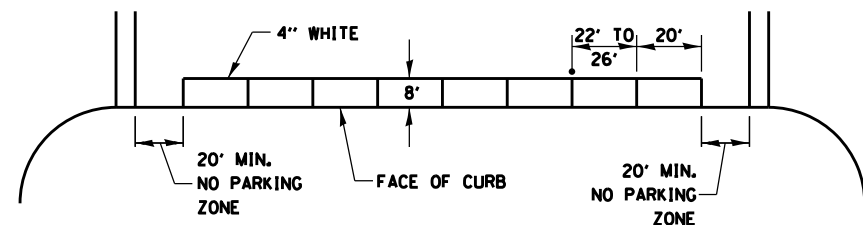

**OPTION 2**

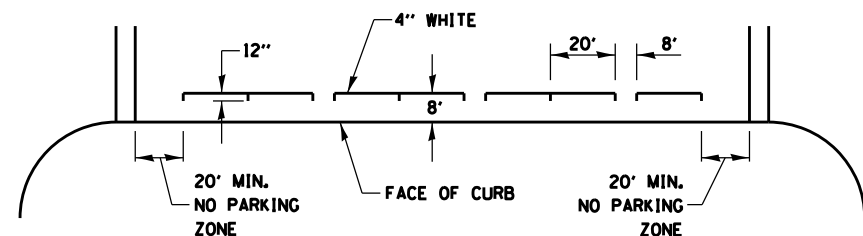

**OPTION 3**

**TYPICAL PARKING SPACING**

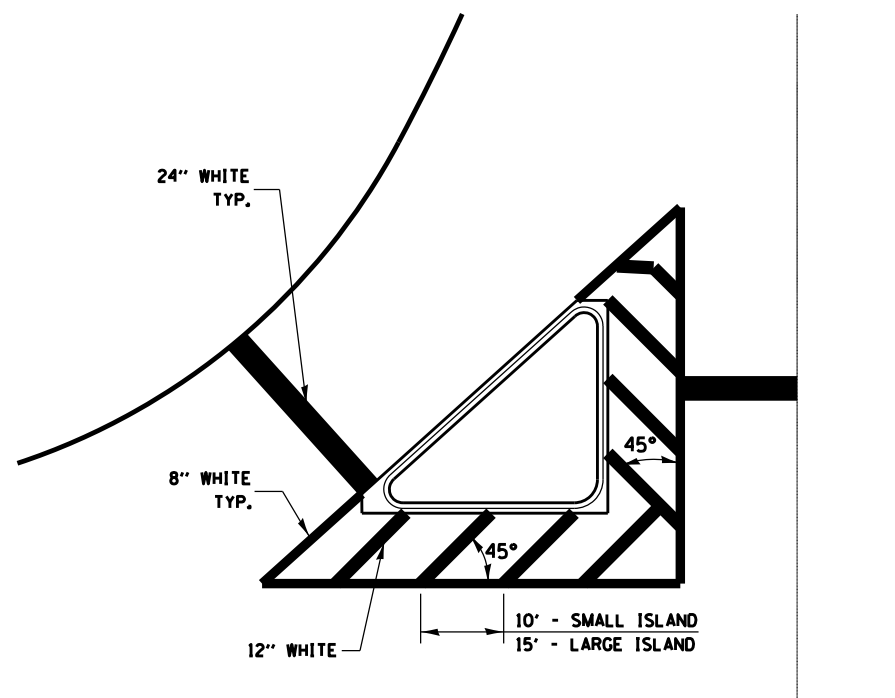

**TYPICAL ISLAND**

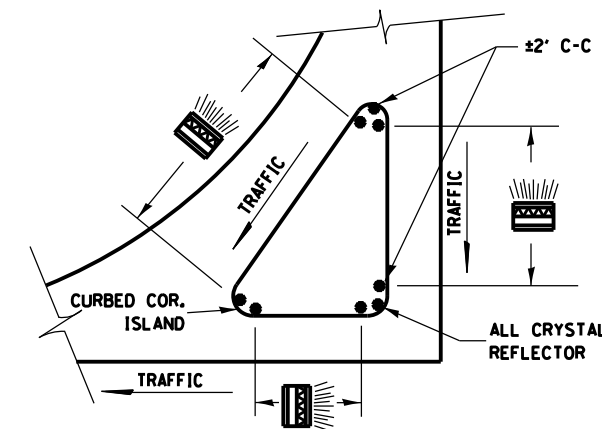

**PRISMATIC REFLECTORS**

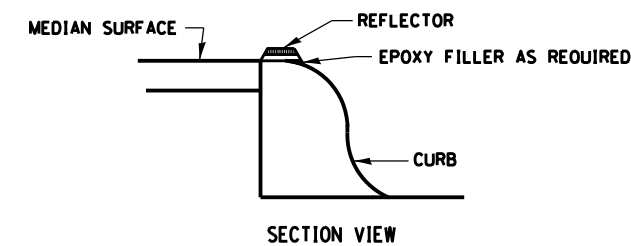

**SECTION VIEW**

**NOTES**

1. PRISMATIC REFLECTORS SHALL BE MONO-DIRECTIONAL AND POSITIONED SO THAT THE REFLECTIVE FACE IS FACING THE APPROACHING TRAFFIC.
2. PRISMATIC REFLECTORS SHALL BE SECURED IN PLACE WITH AN EPOXY ADHESIVE.
3. PRISMATIC REFLECTORS SHALL BE EITHER AMBER OR CRYSTAL IN COLOR.

FILE NAME = #FILE#	USER NAME = #USER#	DESIGNED -	REVISED -	STATE OF ILLINOIS DEPARTMENT OF TRANSPORTATION	DETAILS			F.A.P. RTE.	SECTION	COUNTY	TOTAL SHEETS	SHEET NO.			
		DRAWN -	REVISED -		SCALE:	SHEET	OF	SHEETS	STA.	TO STA.	573	(116RS-5)	DEKALB	43	39
		CHECKED -	REVISED -												
		DATE -	REVISED -												
											CONTRACT NO. 66812				
											ILLINOIS FED. AID PROJECT				