

**END VIEW**

\* The Location of the elevation at the top of crashwall shown in the Pier Elevation view.

\*\*For Piers 1 & 4 only.

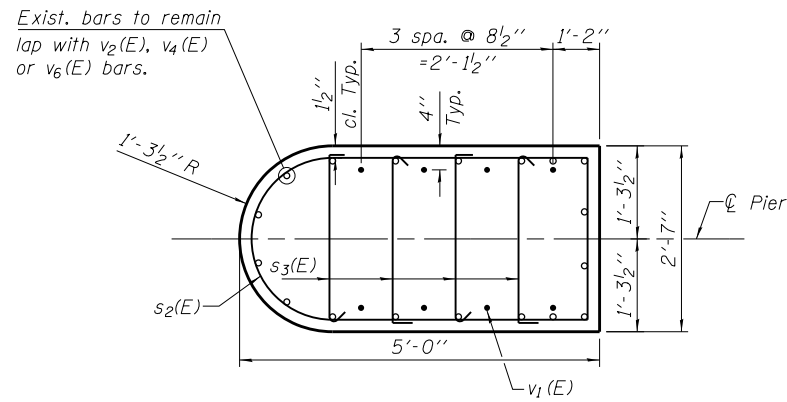

**SECTION B-B**

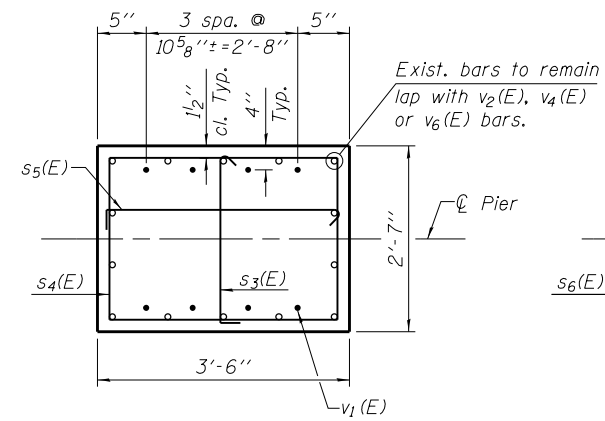

**SECTION C-C**

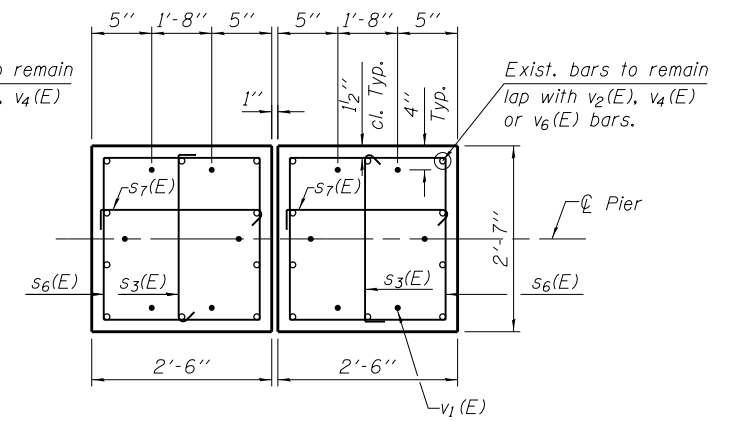

**SECTION D-D**

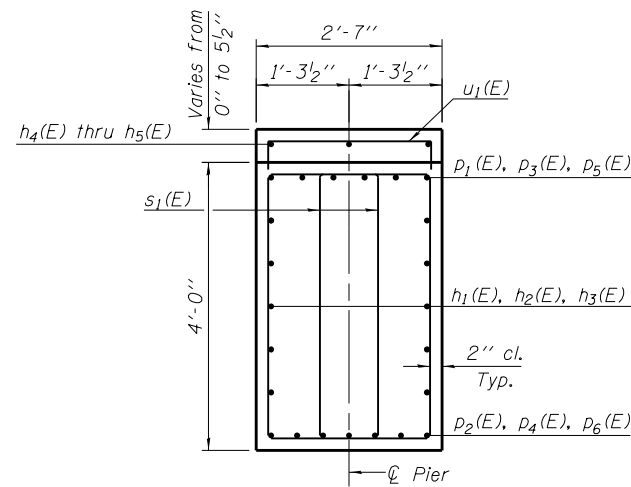

**SECTION A-A**

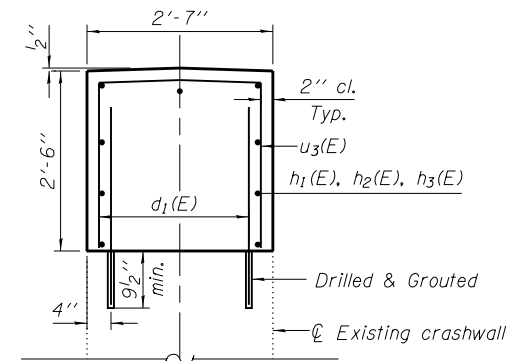

**SECTION E-E**

H:\projects\2013\20130221\CAD\Structure\dt.dgn\06-1149\_Final\00\Di60J15-s46-pier-dt.dgn 5/20/2013 11:24:48 AM

USER NAME =	DESIGNED - J.Z.	REVISED -
CHECKED - J.A.Z.	REVISED -	
PLOT SCALE =	DRAWN - E.E.J.	REVISED -
PLOT DATE =	DATE - 5/17/2013	REVISED -

F.A.I. RTE.	SECTION	COUNTY	TOTAL SHEETS	SHEET NO.
94	1920-B	COOK	137	105
CONTRACT NO. 60J15				