

When cantilever forming brackets are used, the work shall be done according to Article 503.06(b) of the Standard Specifications, except as modified below and in the details shown on this sheet.

The finishing machine rails shall be placed on the top flange of the exterior beams.

The beams or girders, supporting cantilever forming brackets, shall be tied together at 4 foot intervals.

For Standard construction, or Stage Construction the Hardwood bracing materials shall be placed as shown between webs of beams in each bay.

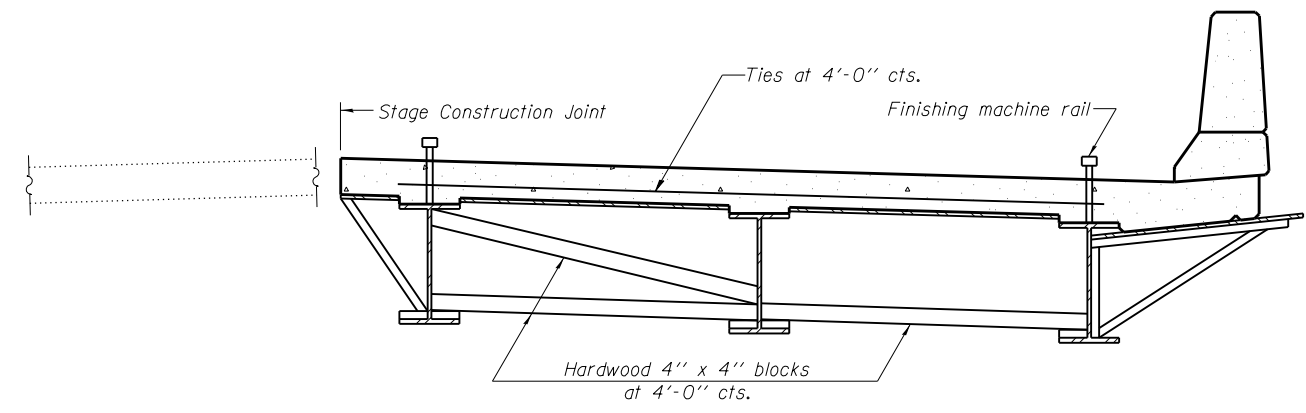

**FORM BRACES FOR
STAGE CONSTRUCTION**

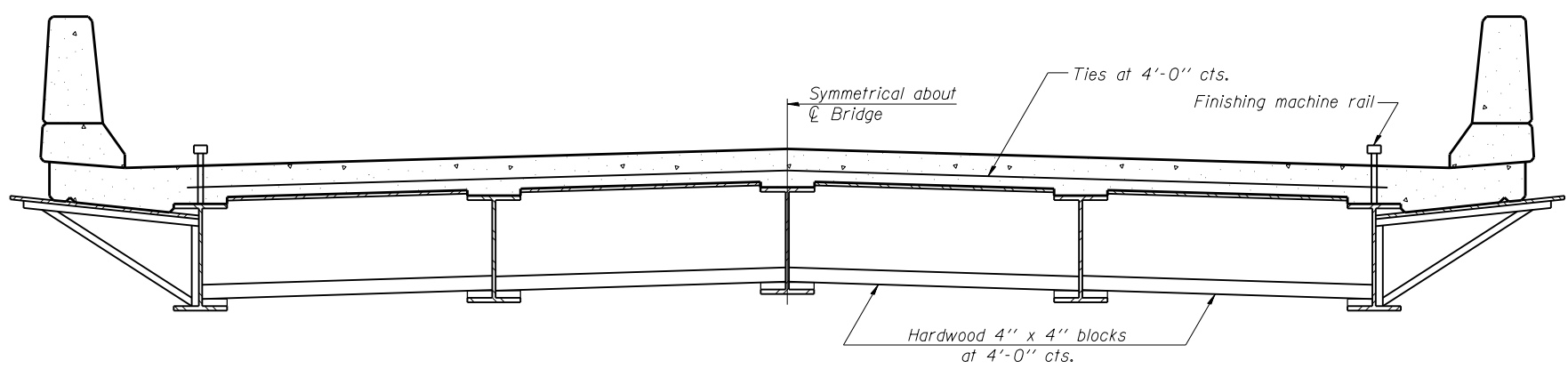

**FORM BRACES FOR
STANDARD CONSTRUCTION**

H:\projects\2013\0221\CAD\Structural\dgn\016-1149_Final\00\Di60J15-s50-cant.dgn 5/20/2013 11:24:49 AM

SB-1 7-1-10

GR̄EF
8501 W. Higgins Road, Suite 280
Chicago, Illinois 60631; (773) 399-0112

USER NAME =	DESIGNED - J.Z.	REVISED -
	CHECKED - J.A.Z.	REVISED -
PLOT SCALE =	DRAWN - E.E.J.	REVISED -
PLOT DATE =	DATE - 5/17/2013	REVISED -

**STATE OF ILLINOIS
DEPARTMENT OF TRANSPORTATION**

**CANTILEVER FORMING BRACKETS FOR SUPERSTRUCTURE
STRUCTURE NO. 016-1149**

SHEET NO. S50 OF 50 SHEETS

F.A.I. RTE.	SECTION	COUNTY	TOTAL SHEETS	SHEET NO.
94	1920-B	COOK	137	109
CONTRACT NO. 60J15				
ILLINOIS FED. AID PROJECT				